

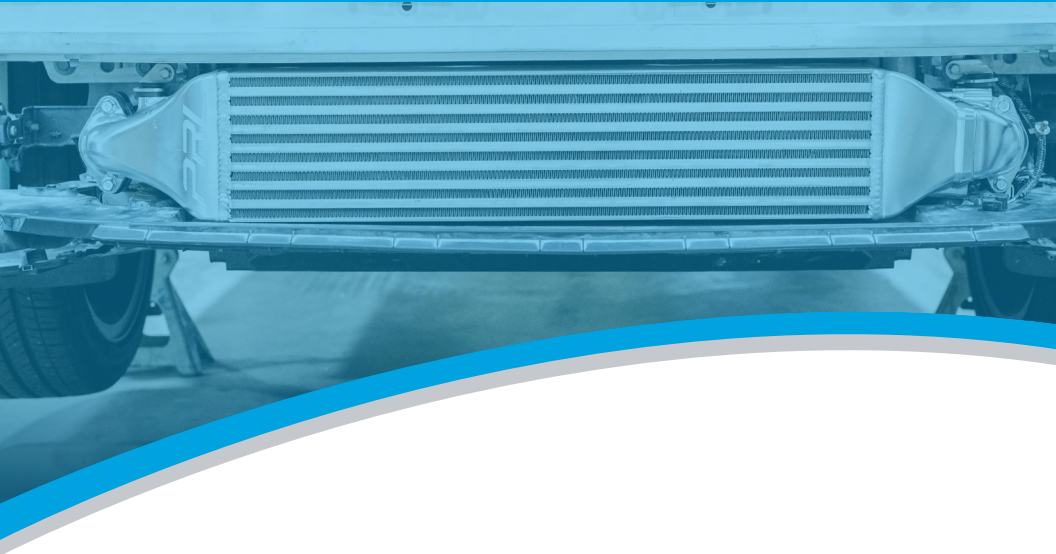

## INSTALLATION GUIDE



HONDA CIVIC 1.5T (2022-2023)  
FRONT MOUNT INTERCOOLER

# PRL INSTALLATION OVERVIEW

**PRODUCT:** PRL-HC11-IC PRL MOTORSPORTS FRONT MOUNT INTERCOOLER

**FITMENT:** 2022-2023 Honda Civic 1.5L Turbo

**INSTALLATION TIME:** Approximately 1 hour

**NOTE:** THIS ITEM DOES NOT REQUIRE AN ECU RE-CALIBRATION.

Please check that all components that are listed in the parts list have been supplied to you, and are correct. If you require any assistance or are missing components please email: [support@prlmotorsports.com](mailto:support@prlmotorsports.com). Please verify with a customer service representative before installation or returning the product.

## PRODUCT DISCLAIMER:

United States 48 State Compliant:

California/New York Residents please see Prop 65.

This is a Race Only product that is to be used solely for competition, it cannot be used on vehicles that are operated on public streets, roads or highways. Its use is limited to closed-course and open-course racing that is formally sanctioned by a recognized racing organization. Any other use including recreational use could be in violation of local, state and federal laws.

PRL Motorsports is not responsible for any vehicle damage or personal injury that may occur due to an installation error, product misuse, or removal of PRL Motorsports products.

PRL Motorsports highly suggests that a trained professional conduct the installation on all products. PRL Motorsports is not responsible for damaged products due to incorrect installation.

## REQUIRED TOOLS:

Ratchet

Extension (6 - 12" Length)

10mm Socket

12mm Socket

Torque Wrench

Pliers

Phillips Head Screw Driver

Flat Head Screw Driver

Clip Removal Tool

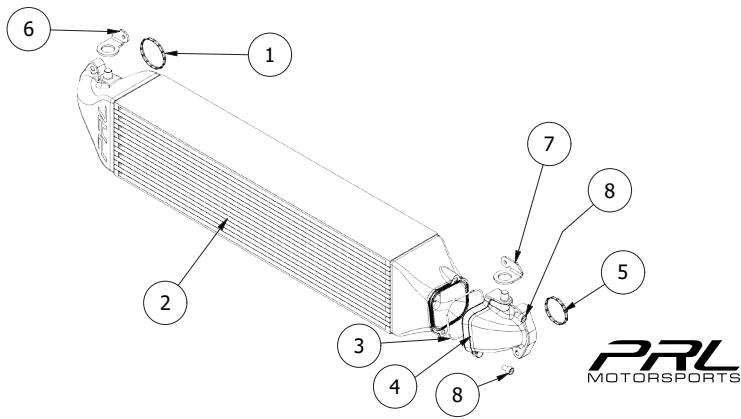

## COMPONENT LIST

#	PART #	QTY	DESCRIPTION
1	RAW-HC11-ORING-A	1	Hot Side End Tank O-Ring
2	RAW-HC11-IC-ASSY	1	2022-2023 Honda Civic Front Mount Intercooler
3	MCM-9452K174	1	-153 Buna O-Ring
4	RAW-HC11-IC-OUT-STK	1	2022-2023 Honda Civic Cold Side End Tank-B
5	RAW-HC11-ORING-B	1	Cold Side End Tank O-Ring
6	RAW-HC11-IC-BKT-A	1	2022-2023 Honda Civic Intercooler Bracket A
7	RAW-HC11-IC-BKT-B	1	2022-2023 Honda Civic Intercooler Bracket B
8	MCM-91292A207	2	Socket Head Cap Screw M8x1.25x12
9	PRL-HCR-IC-STEN	1	Standard PRL Logo Stencil (Cardboard)

## Before Beginning Your Installation:

1. Turn off the ignition. Loosen battery terminal and disconnect the negative battery terminal cable. Allow the vehicle to sit for a minimum of 5 minutes to drain any remaining charge from the charging system.

**NOTE: Disconnection of the negative battery cable erases pre-programmed electronic memory. We recommend saving any memory settings before disconnecting the negative terminal. Some radios will require an anti-theft code to be entered after the negative battery cable is reconnected.**

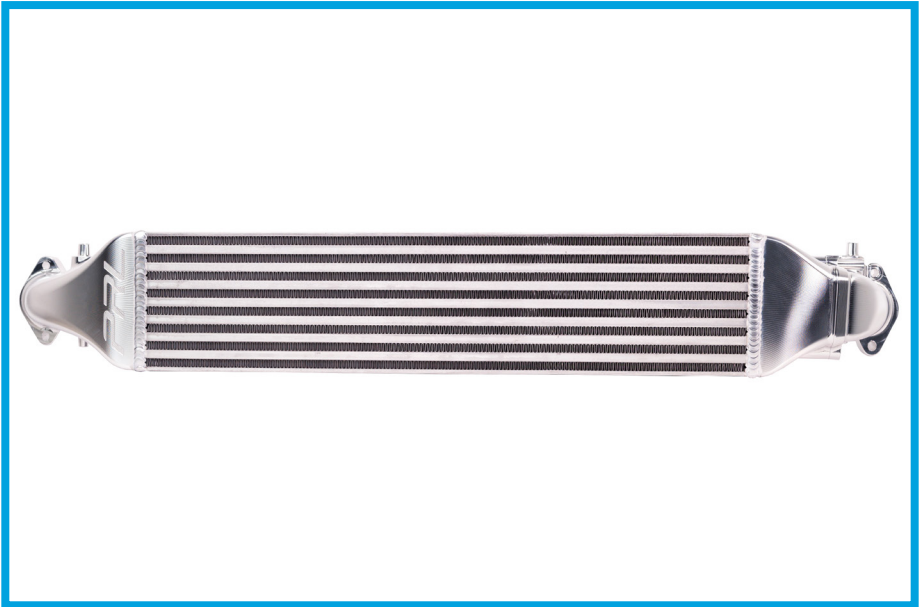

## Preparing Your Front Mount Intercooler:

2. Set on even, clean surface to ensure to not damage the intercooler while removing the front bumper. Reference the parts list and ensure all components are enclosed. If something is missing, please contact PRL Customer Support.

3. The front bumper of the car will need to be removed to access the factory intercooler. If applying the stencil, follow the next 2 steps, if not, skip to step 6.

4. Rotate and ensure you have the PRL Front Mount Intercooler facing the correct orientation. The passenger side has the PRL logo engraved into the tank.

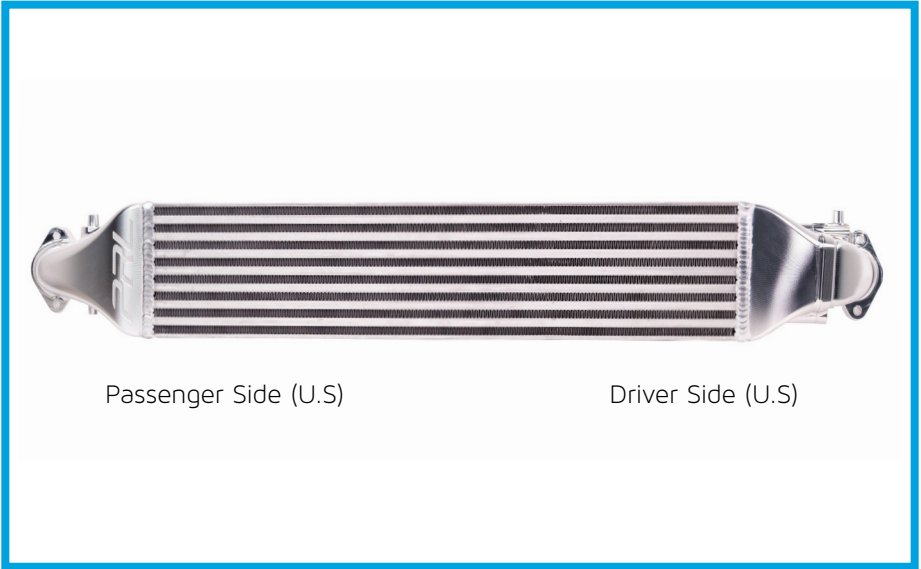

5. PLEASE NOTE: If you are applying the PRL Logo utilizing our stencil, do so when the PRL Front Mount Intercooler is NOT installed. This is to avoid overspray onto the paint and trim.



6. **OPTIONAL, BUT RECOMMENDED:** To protect your vehicle from damage while removing the front bumper, wrap a shop towel around your hood latch and tape off the edge of the front fender and headlight assembly.



7. Remove the (3) bumper clips above each headlight. You can utilize a flathead screwdriver, or a clip removal tool. Be sure to not damage the clips during this process. If any are snapped, visit your local Honda dealer for replacements.

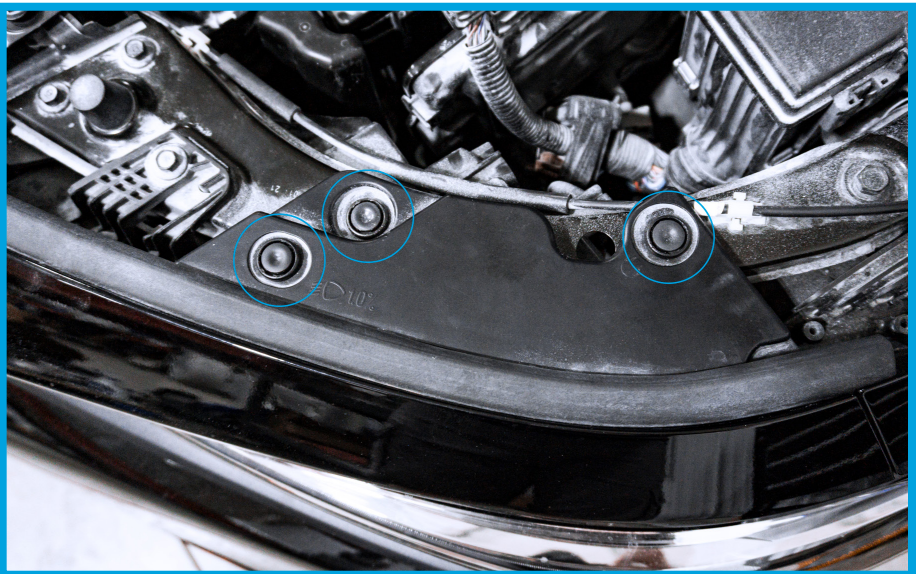

8. Remove the (2) bumper clips to the inside of the headlight.

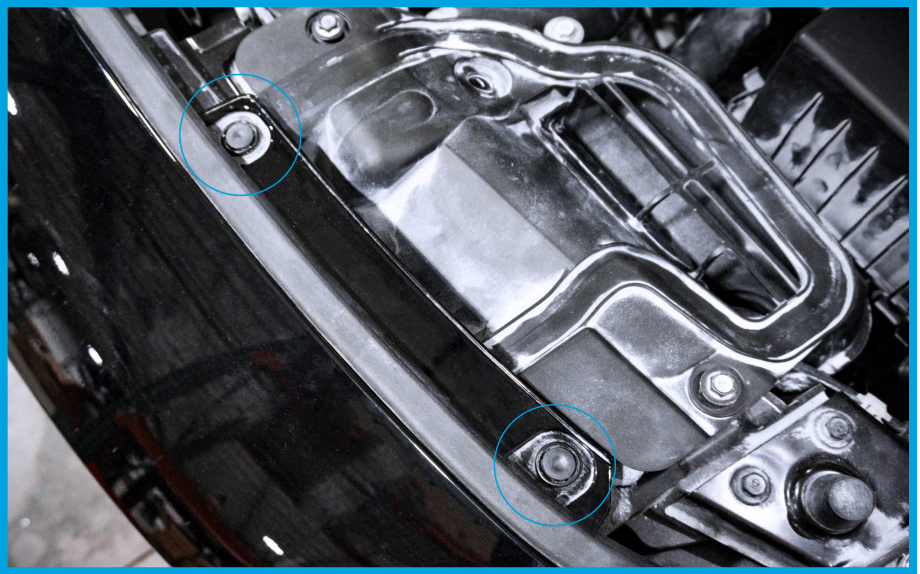

9. Remove the (1) lower Phillips head screw inside each of the wheel well arches. This holds the bumper to the fender liners.



10. Remove the (1) upper Phillips head screw inside each of the wheel well arches. It is located above the circled clip, where the bumper and fender connect.



11. On the underside remove (10) bumper clips along the front section. They are circled in blue in the image below. There are (1) 10mm shoulder bolts and (1) Phillips head screws per side. They are circled in white in the image below.

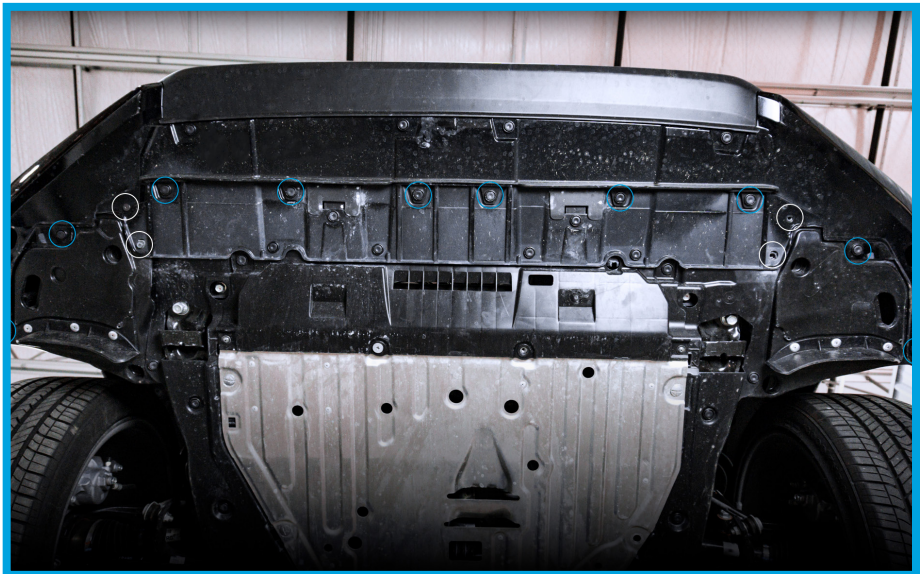

12. Before fully removing the bumper, unclip the top harness which is above the Honda badge, near the hood latch. This will need reconnected when putting the bumper back on after the installation is complete.

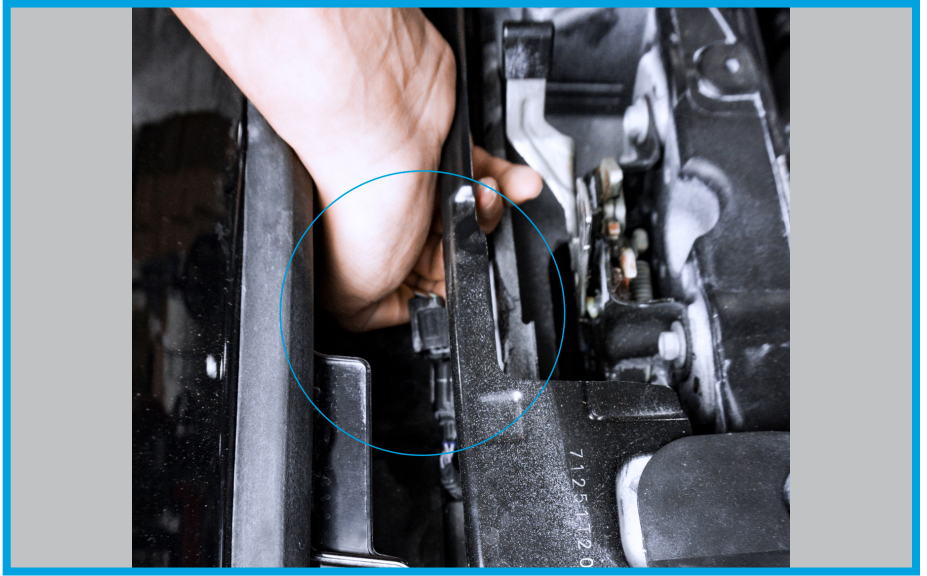

13. Unclip the fog light harness and sensor harness on each side of the bumper before fully pulling the bumper away from the car. These will need reconnected when putting the bumper back on after the installation is complete.

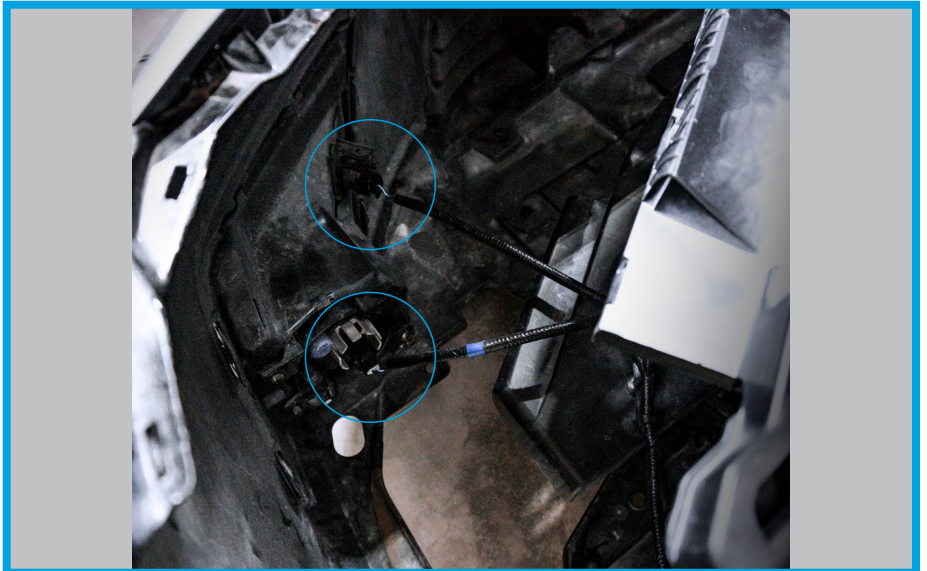

14. After fully pulling the bumper away from the car, place on a flat, covered surface to avoid scratching the bumper.



15. Remove (2) 10mm from the front of the bumper plastic attached to the bumper beam.



16. Remove the (4) bumper clips from the grille insert with a flat head screwdriver.



17. Remove the (2) bumper clips from the underside of the grille insert. There is one clip on either side towards the outside of the grille insert.

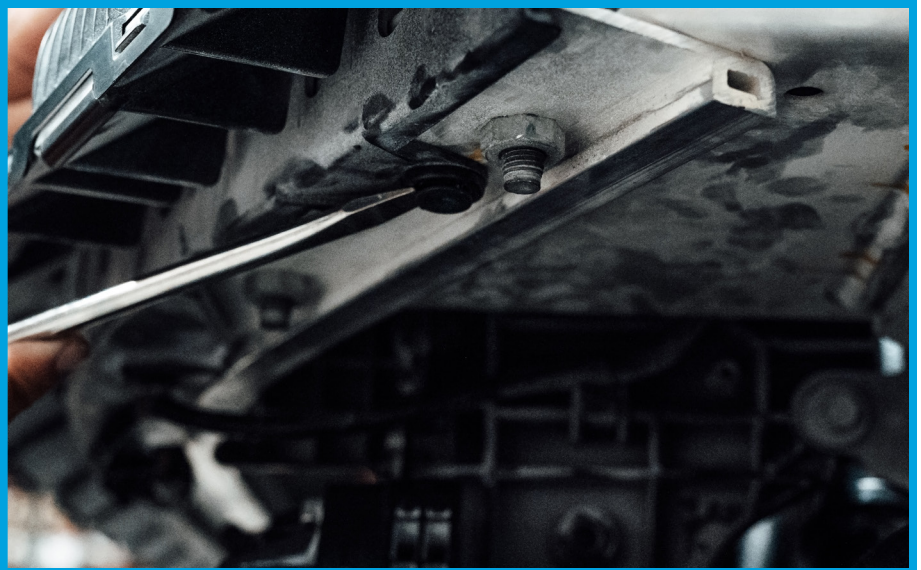

18. Using a set of pliers, squeeze the side of the tabs holding the clip to release the ambient air sensor from the upper plastic shroud.



19. Remove (1) 10mm from each of the upper mounting brackets holding the factory intercooler into place. These bolts will be re-used with the provided brackets.



20. Remove the factory rubber grommet from each of the factory mounting brackets. The rubber grommet will be reused in the PRL mounting bracket.



21. Remove the (2) 10mm bolts holding the intercooler to the factory charge pipes. These will be re-used for the PRL Intercooler Upgrade.

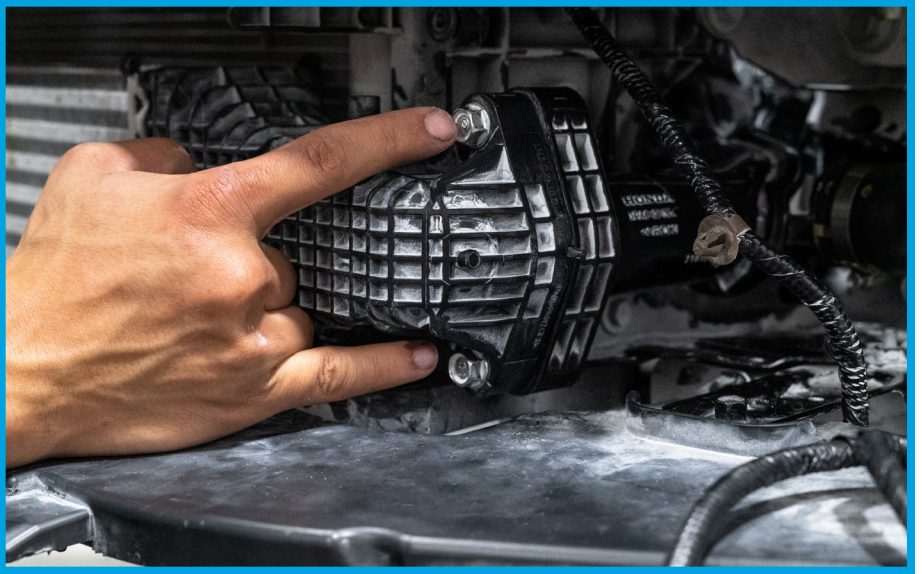

22. Install the (1) larger provided O-ring in the groove on the outlet located on the driver's side (U.S.) before attaching the outlet end tank fully to the intercooler.



23. Install the outlet end tank fully to the intercooler with the (2) 10mm socket head bolts.

**\*\* RECOMMENDED TORQUE SPEC - 18 ft/lbs \*\***



24. Install the (2) smaller provided O-rings both the inlet and outlet grooves. Seat the factory rubber grommet on the bottom post on each side.



25. Mount the intercooler so that the rubber grommet is seated on the post and tighten the PRL upper bracket using the (1) factory 10mm bolt on each side.

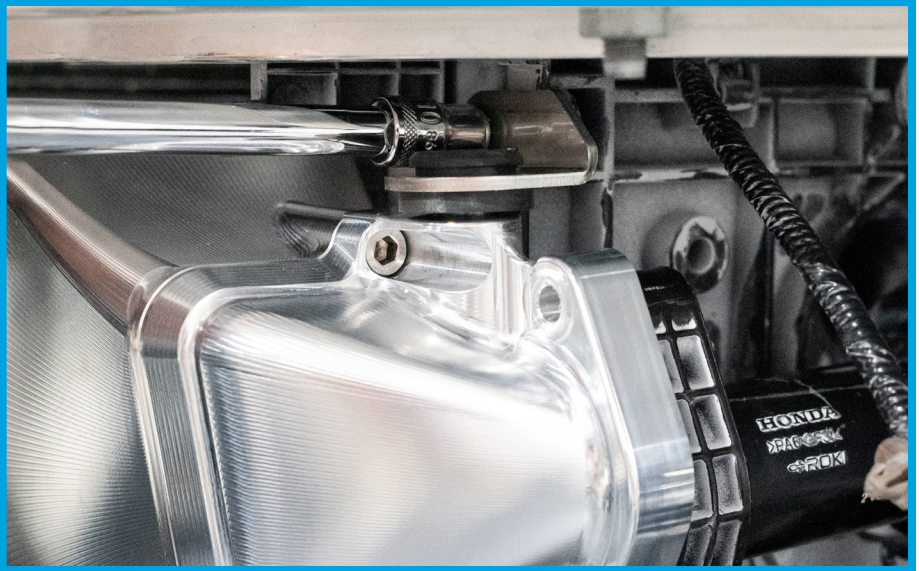

26. Align the factory charge pipes, ensuring they are flush and connect them together using the (2) factory 10mm bolts. Gradually apply torque to each bolt to avoid displacing the o-ring from the intercooler groove.

**\*\* RECOMMENDED TORQUE SPEC - 18 ft/lbs \*\***

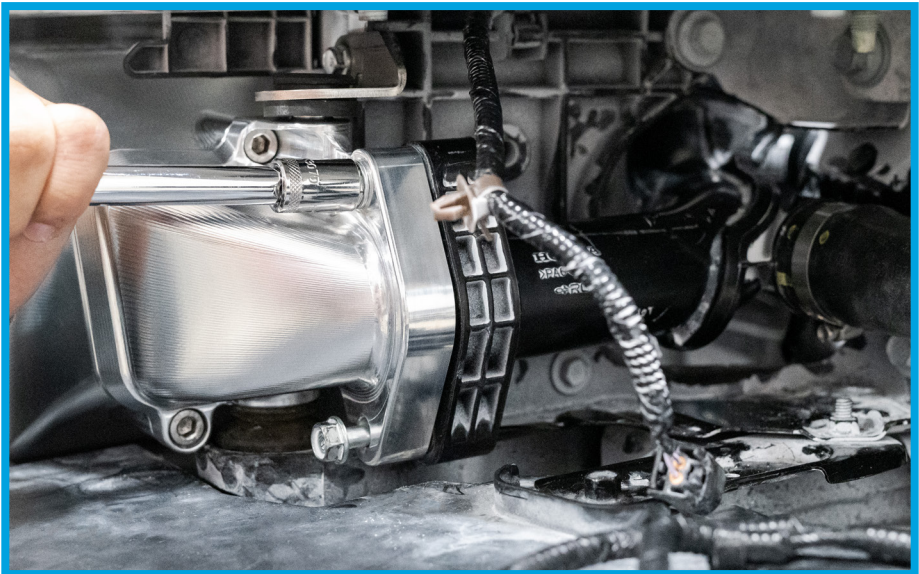

27. The ambient air sensor (that was unclipped earlier in the guide) will need to be flipped on the other side of the tab that holds it into place, in order to clear the end tank. Double check all connections are flush, and hardware is torqued.

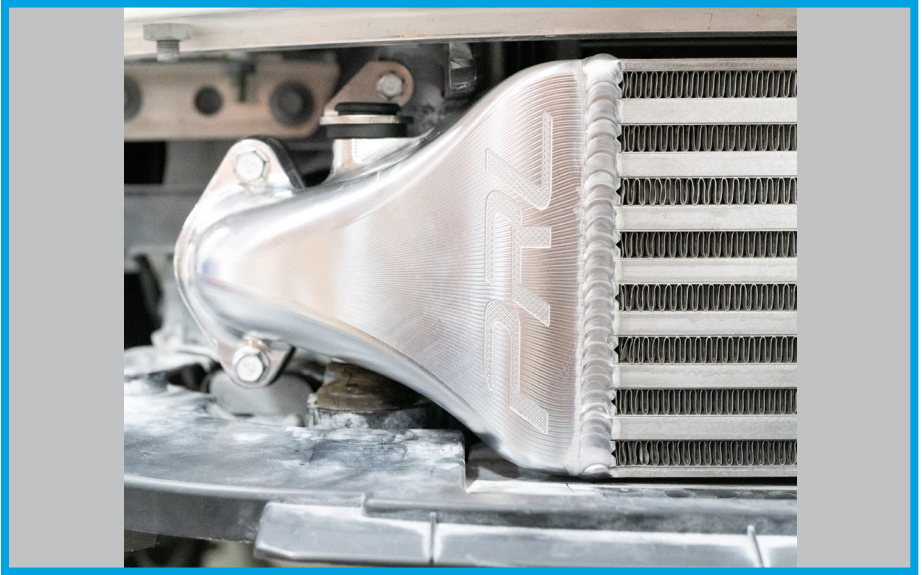

28. If all connections are tight and components are in place, you can begin the bumper re-installation. Follow the bumper removal steps in reverse order.

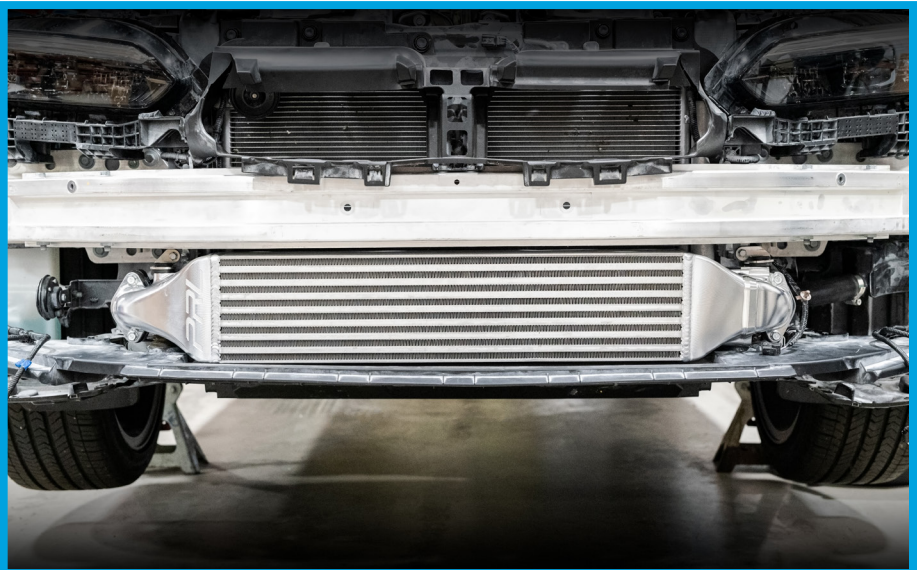

## Road Testing Your PRL Front Mount Intercooler

1. Start the vehicle with the transmission in neutral and the emergency brake engaged. Assess to make sure of any possible issue(s) and then make any subsequent adjustments as they are needed.
2. Test drive the vehicle to ensure everything is in working order.
3. If after the road testing, everything is good to go, enjoy your PRL Front Mount Intercooler! Thank you for being apart of the #PRLARMY.

**If you have any questions/concerns please reach out to us at:**  
[support@PRLMotorsports.com](mailto:support@PRLMotorsports.com)

Please provide a full description of your issue, ideally with any pertinent images or video clips that can help our team address the issue.

Please note: All support tickets are addressed during business hours and in order of received.

As stated at the beginning of this guide, the PRL Front Mount Intercooler has been specifically designed to be 100% compatible with the factory ECU calibration. No calibration is required to benefit from the advertised gains and performance. Our intercooler is designed to fit like factory but be a more optimal and overall better performing unit. Under conditions in which the horsepower of the vehicle is increased, this unit is rated for 600HP.

## Required Maintenance

PRL Motorsports thoroughly recommends visually inspecting your products during any routine maintenance like oil changes, tire rotations, and filter changes or cleanings. Please make sure to check your connections on all mounted parts periodically to ensure that they have not come loose over time. Always make sure to not drive through any debris that can damage the fins of the intercooler. Nor drive over or into anything that could puncture or crack the intercooler.



1400 RANDALL COURT - UNIT 104  
EXPORT, PENNSYLVANIA 15632

[www.PRLMotorsports.com](http://www.PRLMotorsports.com)

Follow Us!  
PRLMotorsports

