

PARL MOTORSPORTS

INSTALLATION GUIDE



10TH GEN HONDA CIVIC (2016-21) SUBFRAME REINFORCEMENT SYSTEM (SRS)

PRL INSTALLATION OVERVIEW

PRODUCT: PRL-HC10-SRS - PRL MOTORSPORTS SUBFRAME REINFORCEMENT SYSTEM

FITMENT: 2016-21 Honda Civic (Sport, SI, Type-R, Base)

INSTALLATION TIME: Approximately 4-5 hours

NOTE: THIS ITEM DOES NOT REQUIRE AN ECU RE-CALIBRATION.

Please check that all components that are listed in the parts list have been supplied to you, and are correct. If you require any assistance or are missing components please email: support@prlmotorsports.com. Please verify with a customer service representative before installation or returning the product.

PRODUCT DISCLAIMER:

United States 48 State Compliant:

California/New York Residents please see Prop 65.

This is a Race Only product that is to be used solely for competition, it cannot be used on vehicles that are operated on public streets, roads or highways. Its use is limited to closed-course and open-course racing that is formally sanctioned by a recognized racing organization. Any other use including recreational use could be in violation of local, state and federal laws.

PRL Motorsports is not responsible for any vehicle damage or personal injury that may occur due to an installation error, product misuse, or removal of PRL Motorsports products. PRL Motorsports highly suggests that a trained professional conduct the installation on all products. PRL Motorsports is not responsible for damaged products due to incorrect installation.

REQUIRED TOOLS:

Ratchet

Extensions (6 - 12" Length)

Metric Socket Set (10mm-19mm)

Torque Wrench (up to 80 ft/lb minimum)

Jack + Jack Stands





COMPONENT LIST

#	PART #	QTY	DESCRIPTION
1	RAW-HC-RC-1	2	SRS1 - Front
2	RAW-HC-RC-2	4	SRS2 - Front
3	RAW-HC-RC-3	2	SRS3 - Front
4	RAW-HC-RC-4	2	SRS4 - Front
5	RAW-HC-RC-5	2	SRS5 - Front
6	RAW-HC-RC-6	2	SRS6 - Rear
7	RAW-HC-RC-7	2	SRS7 - Rear
8	RAW-HC-RC-8	4	SRS8 - Rear
9	RAW-HC-RC-1	4	SRS9 - Rear
10	Copper Anti-Seize	1	Tube of Copper Anti-Seize

1

Start by lifting your vehicle. Whether using a lift or jack stands. The front subframe should be supported in at least two spots during the installation of the front SRS inserts. Failure to do so may cause damage to the motor/transmission mounts and could cause physical harm.

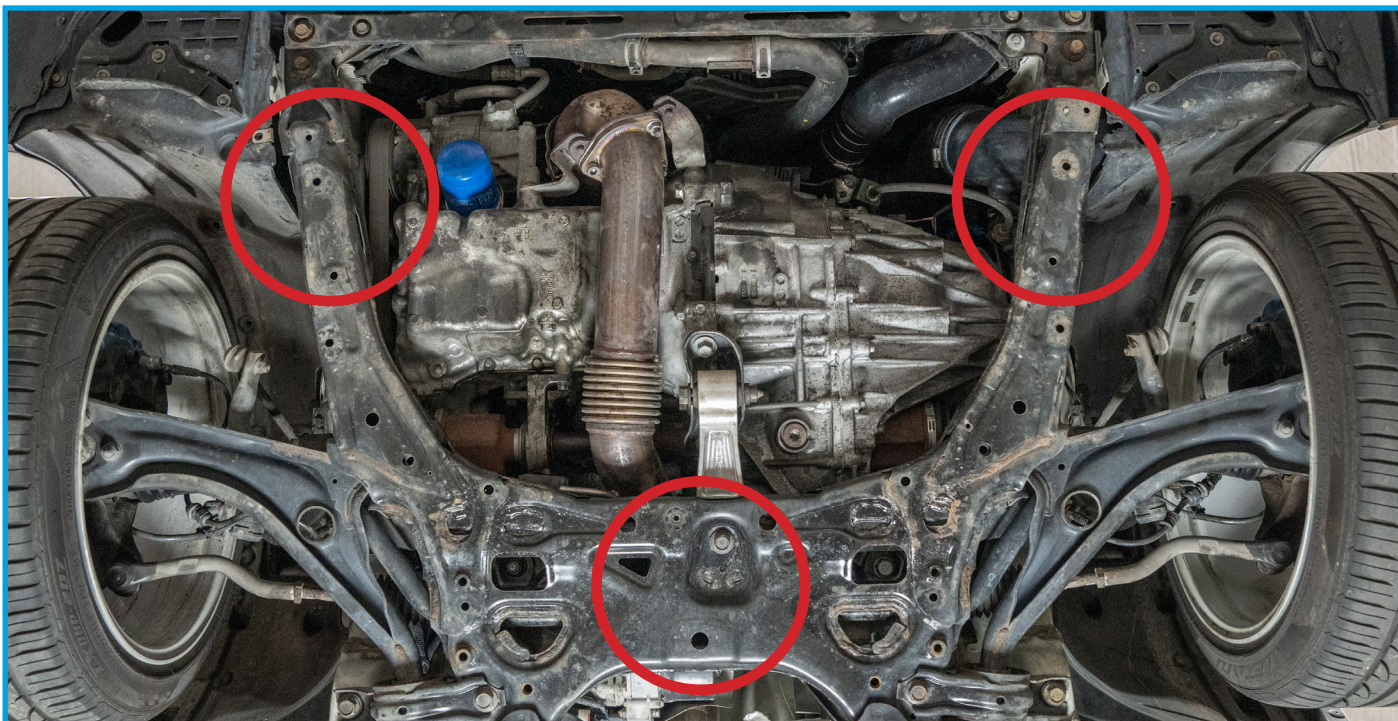

2

Front subframe - Remove the front crossmember brace at the front of the vehicle. Our test car did not have the factory air box, but it may need to be removed to get the crossmember off.



3

Begin loosening all the bolts highlighted for the SRS inserts. Leaving about 2 full turns into the chassis to prevent the subframe and engine from hanging on the upper mounts. Once all the bolts are loosened you will be able to lower the subframe until it is held by the bolts momentarily. With either you pole jack or floor jack raise the subframe back up to just come off the bolt heads. This will give you the maximum clearance.

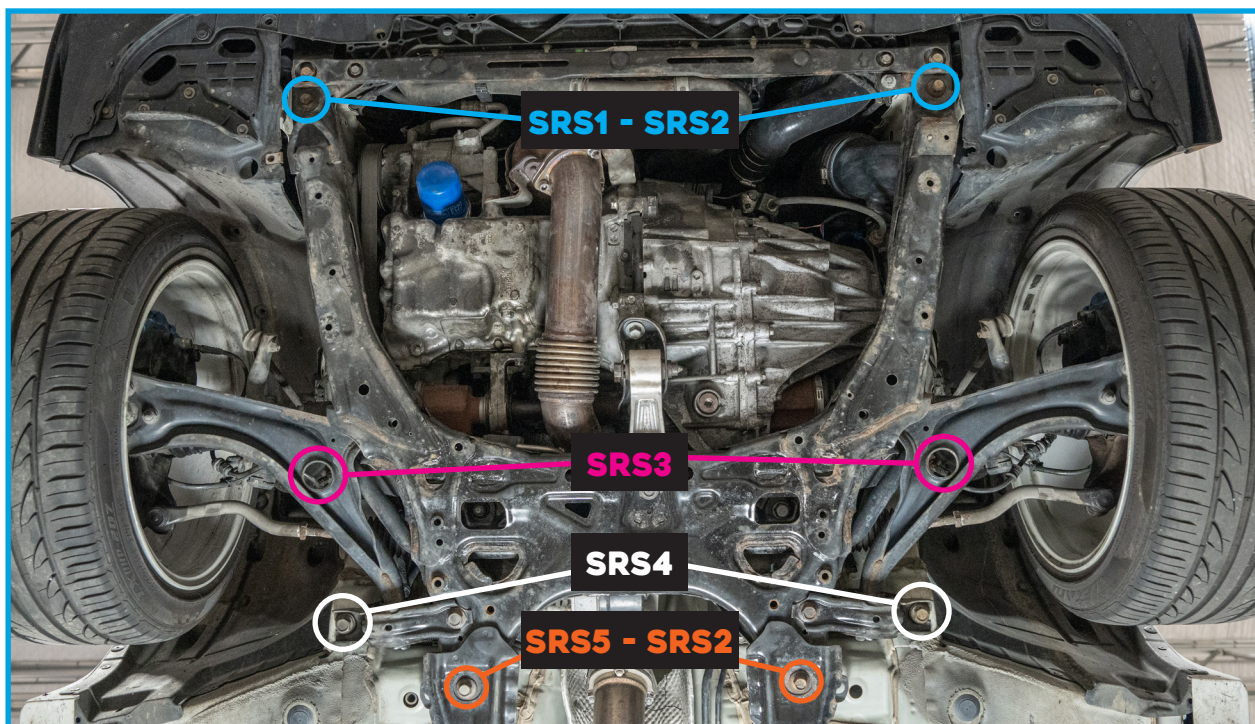

4

We recommend to only install one insert at a time, as well as removing only that associated bolt to prevent the subframe for shifting too much. The SRS inserts will need to be greased with the anti-seize compound supplied. Only the faces of the insert that contact the body and subframe will need to be lubricated. Try preventing any from getting in the hole where the bolt goes, the lubricant will skew the torque reading.

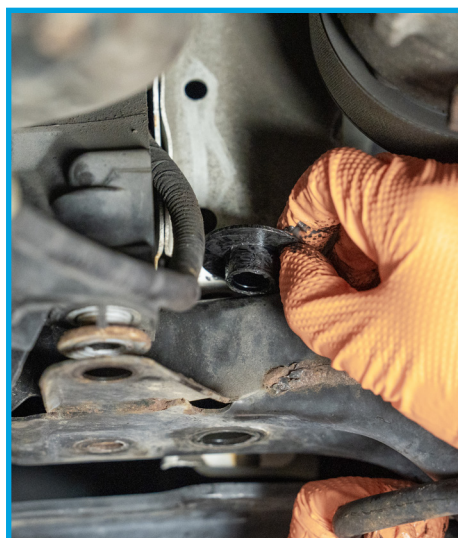

Prying and or manipulating of the subframe may be necessary for most of the inserts to fit. It may also be necessary to manipulate to be able to start threading the bolts on install. **ENSURE TO HAND THREAD THE BOLTS AS MUCH AS POSSIBLE WHEN REINSTALLING WITH THE INSERTS INSTALLED. FAILURE TO DO SO MAY LEAD TO THE BODY THREADS BEING CROSS THREADED.**

5

Using SRS 1 and SRS 2. Repeat for both sides.
 SRS 1 - The text is oriented toward the body
 SRS 2 - The text is oriented toward the head of the bolt.

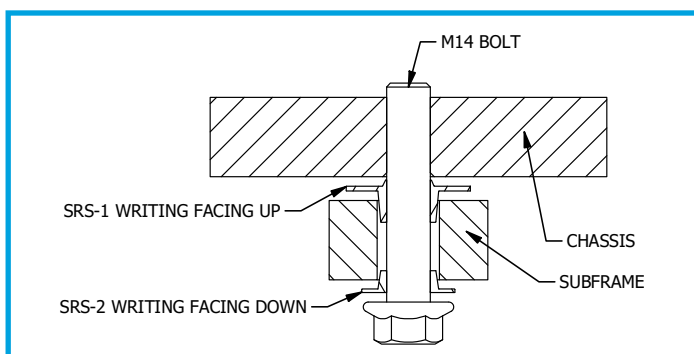

6

SRS 3 requires the 12" extension, to go through the hole in the control arm. Repeat for both sides.
 SRS 3 is oriented with the text facing upwards towards the chassis.

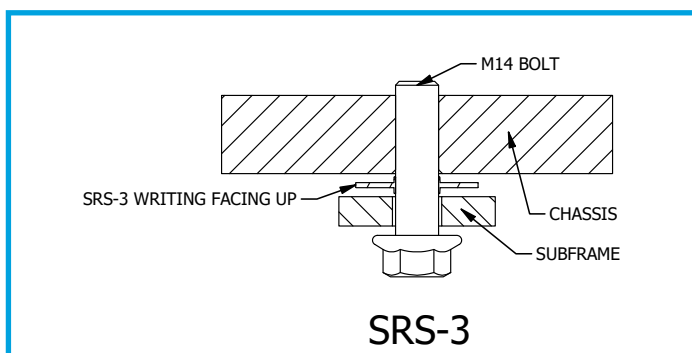

7

SRS 4 - The text is oriented towards the body. Repeat for both sides. The bolt circled in yellow can be loosened to allow for more clearance.

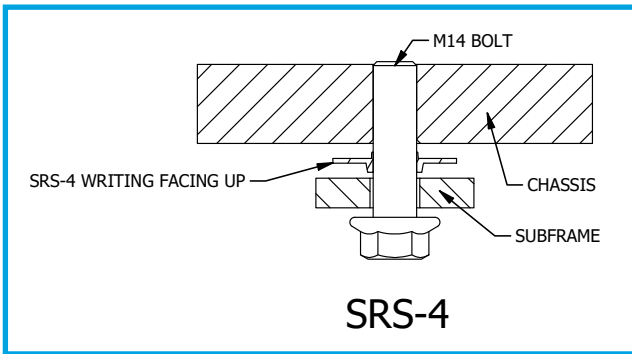

SRS-4

8

Prepping for SRS 5 and SRS 2 - The rear-most front subframe brace bolt will only need to be loosened so that the brace can rotate and be removed. This needs to be done on each side of the car.
SRS 5 - The text is oriented towards the body.
SRS - 2 The text is oriented towards the Chassis brace.
SRS 2 between rear chassis brace and subframe.

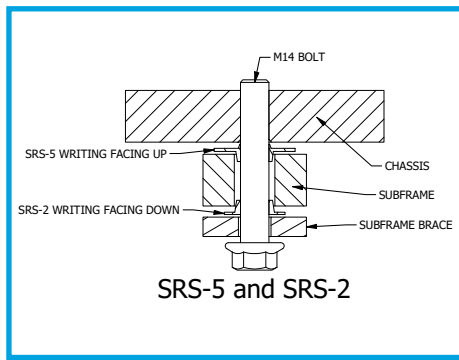

SRS-5 and SRS-2



9

There are two alignment pins at the front of the subframe, insert your alignment rod (15.5mm), through the subframe into the body. Then raise the subframe against the body. Ensure that all the insert's hats are properly seated in the subframe, then tighten each bolt until snug. This prevents the bolt from being used to raise the subframe/engine and possible damaging threads.



10

Finish up the front end by torquing all of the bolts to spec:

Bolts marked in pink should be torqued to 69 ft/lbs for Type R and SI models, 67 ft/lbs for all others

Bolts marked in white are torqued to 76 ft/lbs

Bolts marked in yellow are torqued to 28 ft/lbs

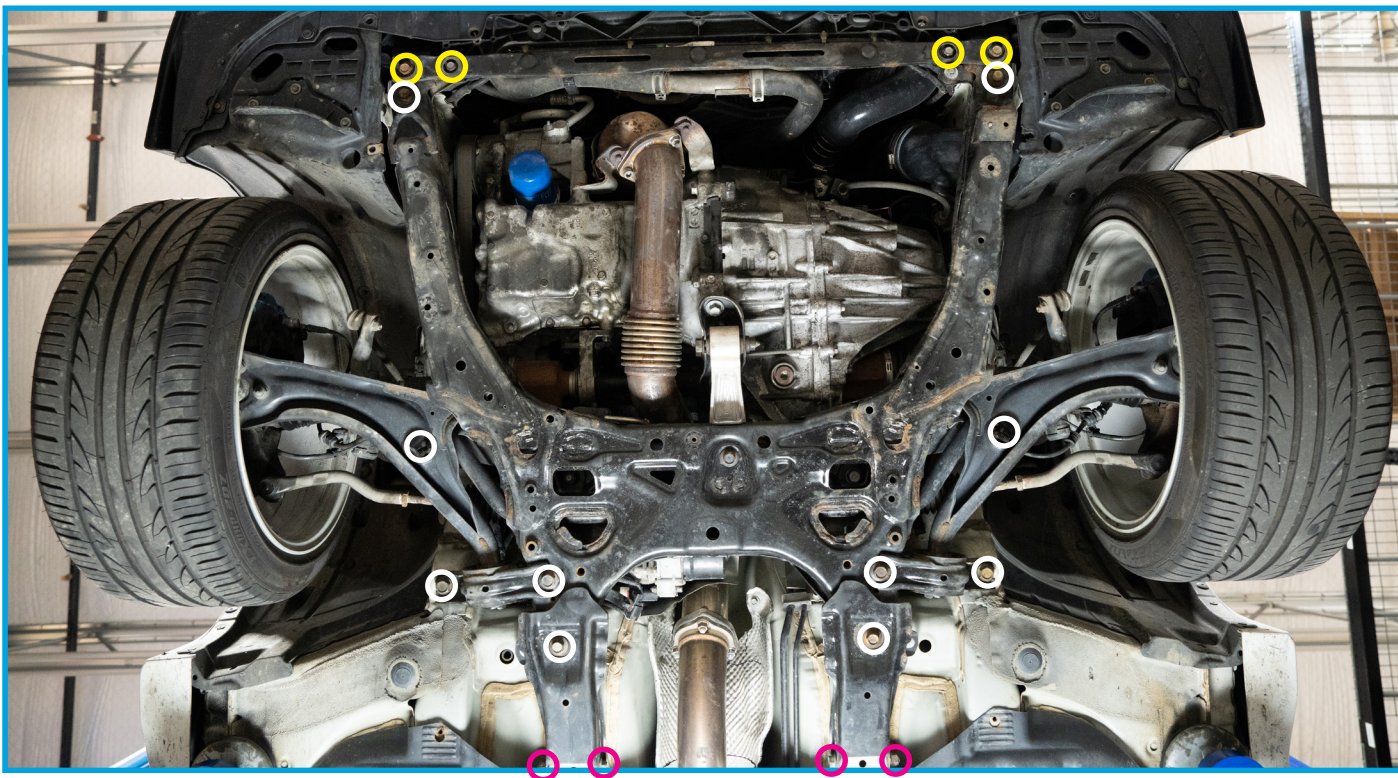

11

Rear Subframe – Use extreme caution when lowering the rear subframe. Only lower it to have just enough room to fit the insert. Failure to do so can cause damage internally to the fuel filler neck.

We recommend supporting it on the cross member as shown in the picture below, either with a jack stand if you are working on the ground or with a pole jack if you have the vehicle on a lift.

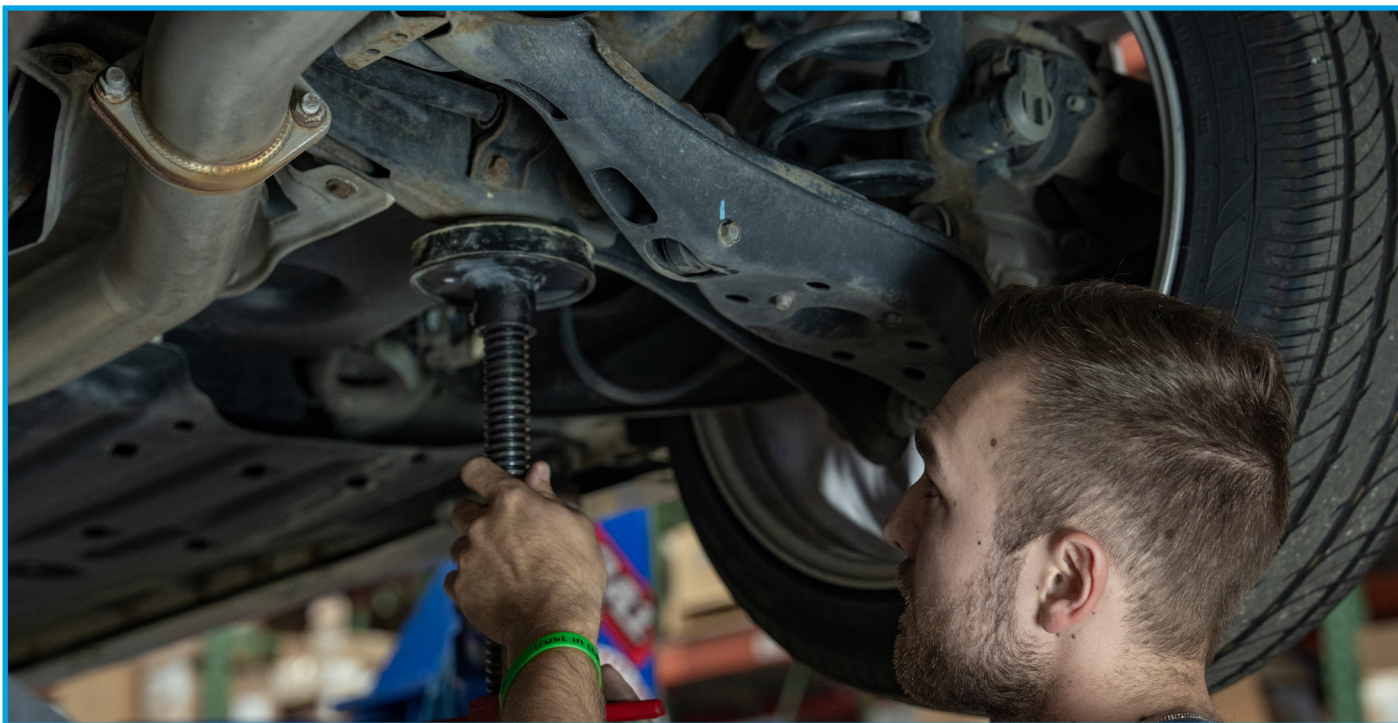

12

For the rear it is easiest to do one side at a time. Loosen all the bolts like the front subframe, leaving at least two full rotations in then lower until you can just fit the insert between the body and subframe.

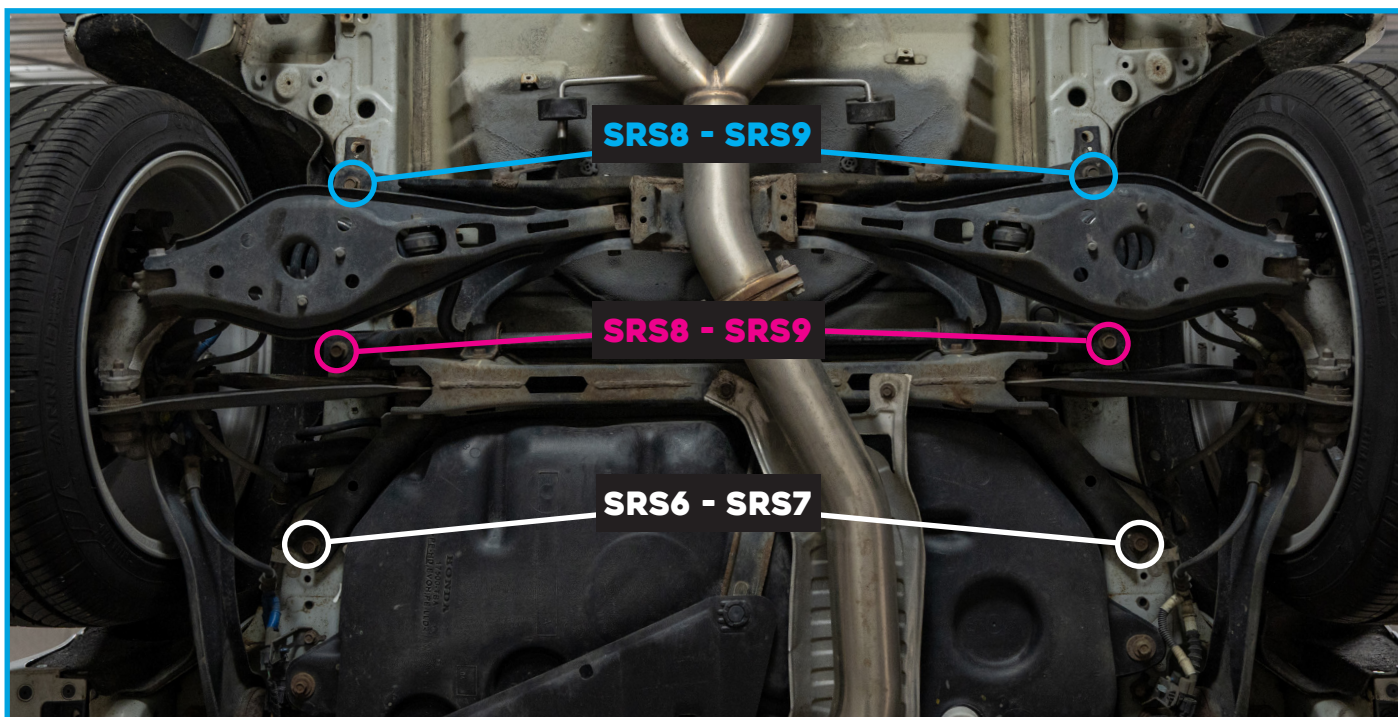

13

SRS 6 and SRS 7
SRS 7 sits between the bolt and the subframe. Text toward the body.
SRS 6 - Text facing up towards the body.

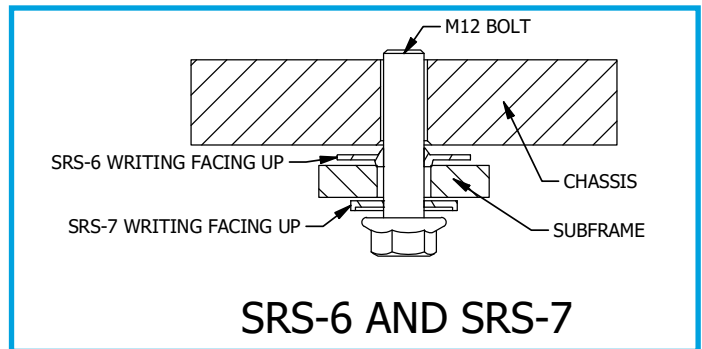

14

SRS 8 and SRS 9 middle section. Although not required a 12" extension makes this step much easier.
SRS 9 between bolt and subframe, text facing down.
SRS 8 text will be facing up towards the body.

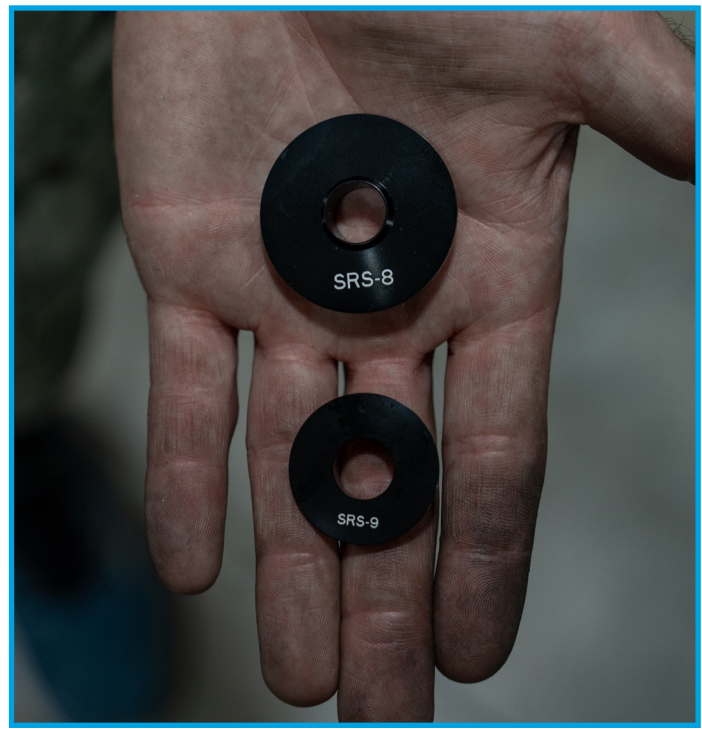
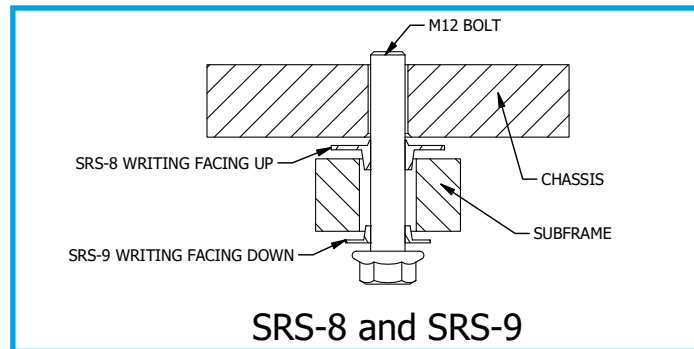

15

SRS 8 and SRS 9 rear section.

Just like in the mid-section SRS 9 goes between bolt and subframe, text facing down.
SRS 8 text will be facing up towards the body.

Repeat steps 13-15 for the opposite side of the car.

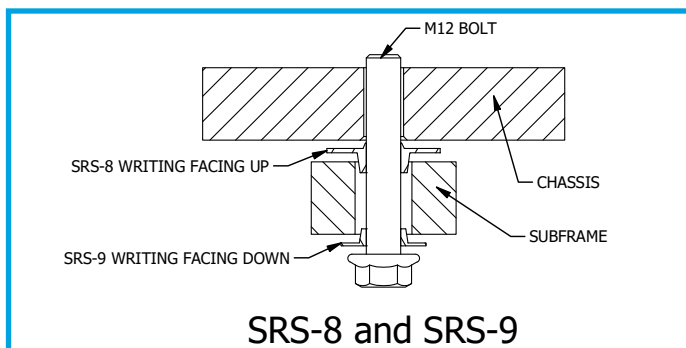

16

Once all inserts installed, insert your alignment rod through the subframe into the body then raise the subframe and hand thread all the bolts. Ensure that all insert hats are seated properly in the subframe.

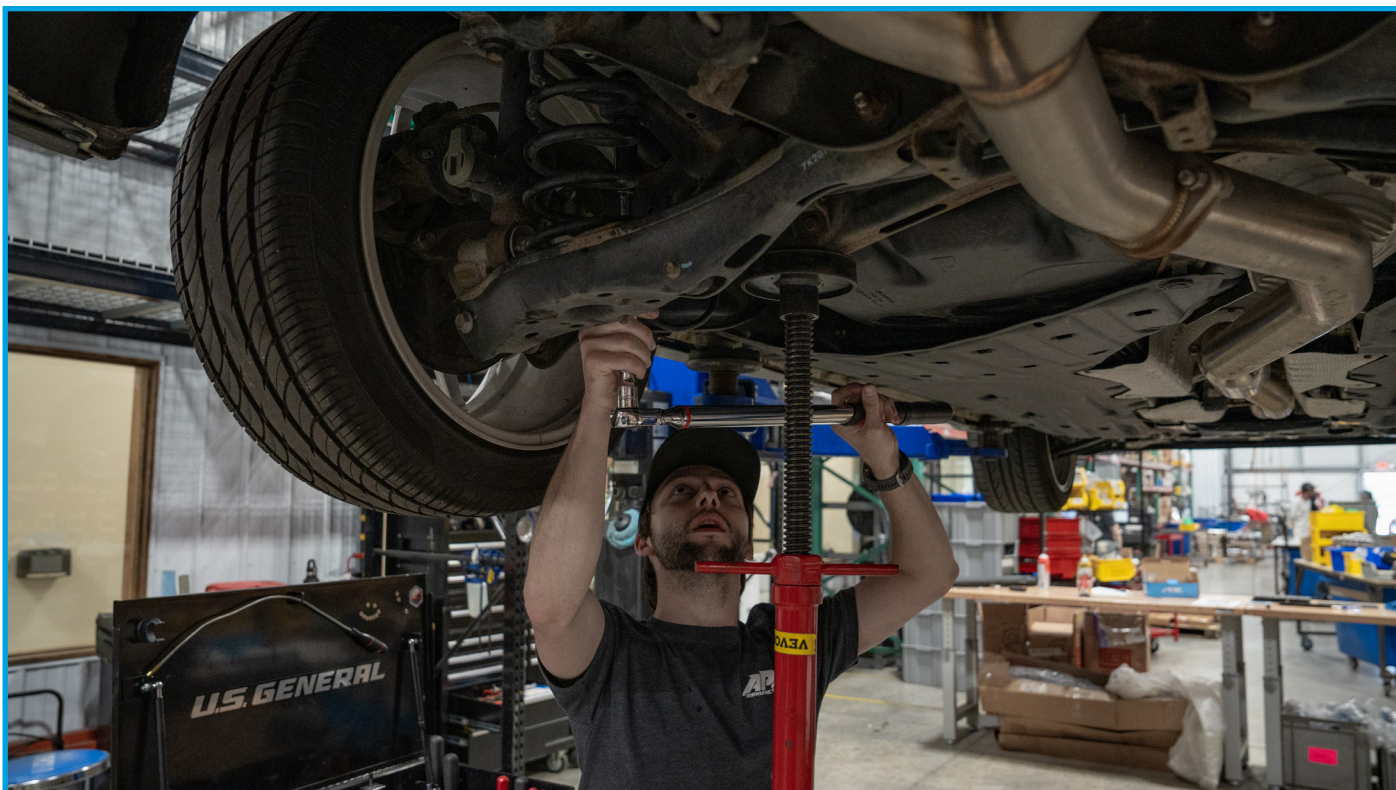

17

For 2 and 4 door vehicles, all 6 bolts are torqued to 54 lb-ft. For 5 door (hatchbacks) they are torqued to 47 lb-ft.

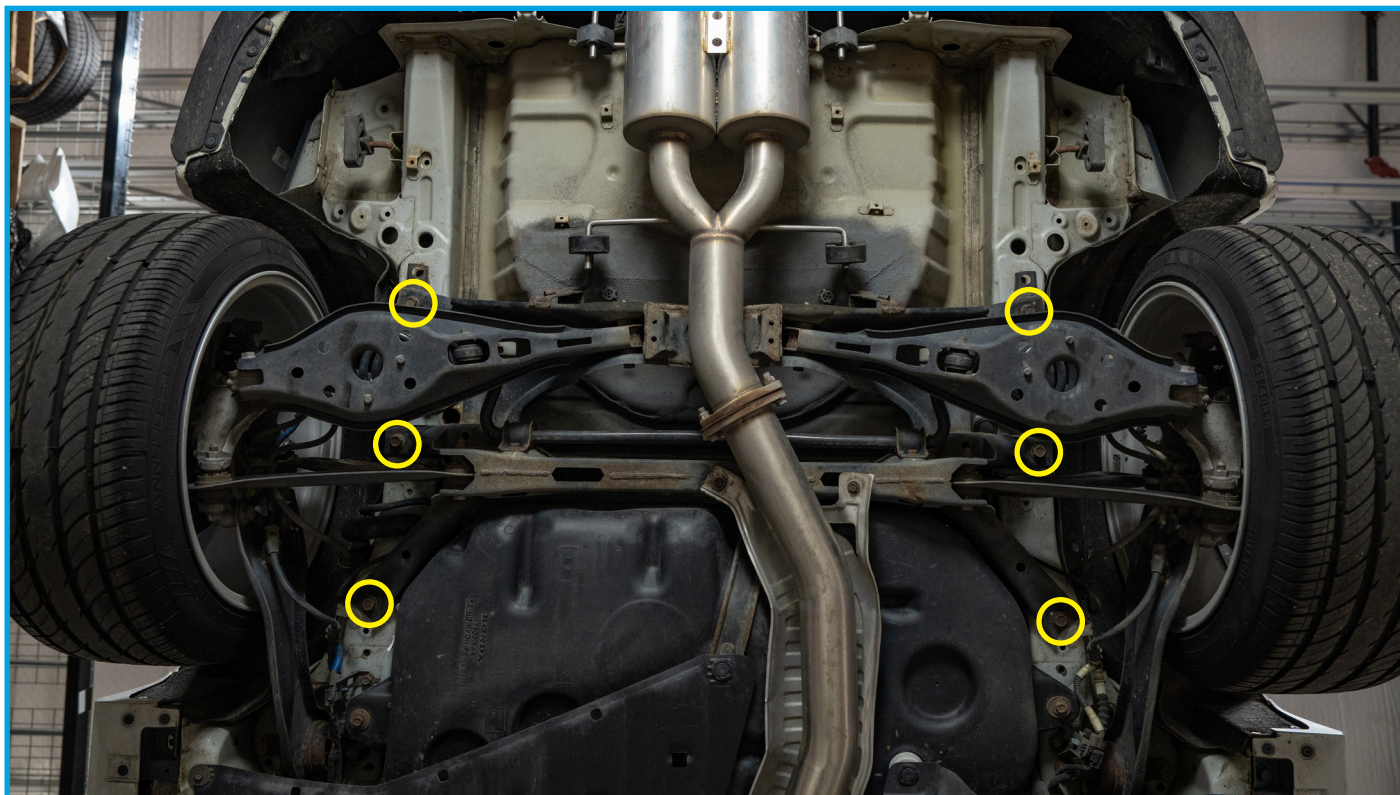

18

Double check your work and take the vehicle for a short test drive.

Finish with an alignment.



Road Testing Your PRL Subframe Reinforcement Kit

1. Take your vehicle for a test drive. Listen for any clunks or groaning from the suspension and chassis. Some noise is to be expected for everything to seat into place.
2. After driving the vehicle for a few miles, you may want to double check the torque specs on all of the hardware to make sure that all of the bolts are still properly seated.
3. Take your vehicle in for an alignment and enjoy the improved chassis feel with your PRL Subframe Reinforcement System! Thank you for being a part of the #PRLARMY.

If you have any questions/concerns please reach out to us at:

support@PRLMotorsports.com

Please provide a full description of your issue, ideally with any pertinent images or video clips that can help our team address the issue.

Please note: All support tickets are addressed during business hours and in order of received.

Required Maintenance

PRL Motorsports thoroughly recommends visually inspecting your products during any routine maintenance like oil changes, tire rotations, and filter changes or cleanings. Please make sure to check your connections on all mounted parts periodically to ensure that they have not come loose over time. Always make sure to not drive through any debris that can damage the fins of the intercooler. Nor drive over or into anything that could puncture or crack the intercooler.



1400 RANDALL COURT - UNIT 104
EXPORT, PENNSYLVANIA 15632
www.PRLMotorsports.com

Follow Us!
PRLMotorsports

