



INSTALLATION GUIDE



HONDA CIVIC 1.5T (2016-2021)
SHORT RAM INTAKE - STREET

PRL INSTALLATION OVERVIEW

PRODUCT: PRL-HC10-INT-SRI-(A OR B) PRL SHORT RAM INTAKE (STREET)

FITMENT: 2016 - 2021 Honda Civic 1.5L Turbo

INSTALLATION TIME: 20-30 minutes

NOTE: THIS ITEM DOES NOT REQUIRE AN ECU RE-CALIBRATION.

Please check that all components that are listed in the parts list have been supplied to you, and are correct. If you require any assistance or are missing components please email: support@prlmotorsports.com. Please verify with a customer service representative before installation or returning the product.

PRODUCT DISCLAIMER:

United States 48 State Compliant:

California/New York Residents please see Prop 65.

This is a Race Only product that is to be used solely for competition, it cannot be used on vehicles that are operated on public streets, roads or highways. Its use is limited to closed-course and open-course racing that is formally sanctioned by a recognized racing organization. Any other use including recreational use could be in violation of local, state and federal laws.

PRL Motorsports is not responsible for any vehicle damage or personal injury that may occur due to an installation error, product misuse, or removal of PRL Motorsports products. PRL Motorsports highly suggests that a trained professional conduct the installation on all products. PRL Motorsports is not responsible for damaged products due to incorrect installation.

REQUIRED TOOLS:

Ratchet

Extension (6 - 12" Length)

10mm Socket

Needle Nose Pliers

Phillips-Head Screwdriver

3mm Hex Key



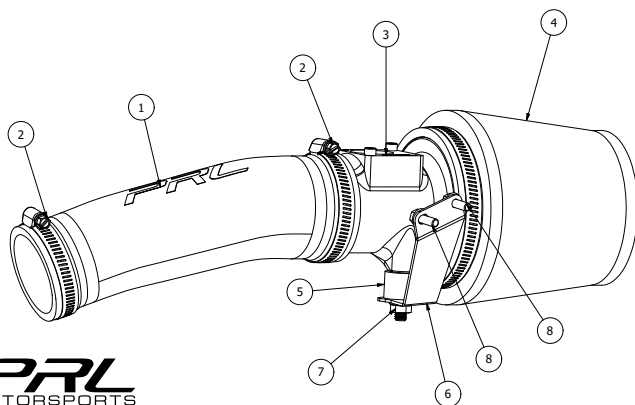

COMPONENT LIST

#	PART #	QTY	DESCRIPTION
1	SIL-HC10-INT-UPR-(A or B)	1	2016-2021 Honda Civic 1.5T Upper Silicone (Street)
2	IFE-60-80-12	2	60-80mm Hose Clamp (Stainless)
3	HC10-INT-MAF-(A or B)	1	2016-2021 Honda Civic 1.5T MAF Housing (Street)
4	PRL-AF-4258	1	PRL Cone Air Filter - 4" Inlet
5	MCM-9217K42	1	Rubber Vibration Damper - M8x1.25
6	RAW-HC10-INT-BKT-C	1	2016-2021 Honda Civic 1.5T Upper Intake Bracket
7	NUT-M8x1.25x12-FNS	1	Serrated Flange Nut M8x1.25x12mm (Zinc)
8	BOLT-M6x1x16-FB	1	Flange Bolt M6x1x12mm (Zinc)
9	IFE-50-70-12	1	50-70mm Hose Clamp (Stainless) - Use with filter

Before Beginning Your Installation:

1. Turn off the ignition. Loosen battery terminal and disconnect the negative battery terminal cable. Allow the vehicle to sit for a minimum of 5 minutes to drain any remaining charge from the charging system.

NOTE: Disconnection of the negative battery cable erases pre-programmed electronic memory. We recommend saving any memory settings before disconnecting the negative terminal. Some radios will require an anti-theft code to be entered after the negative battery cable is reconnected.



Preparing Your Short Ram Intake

2. Reference the parts list and ensure all components are enclosed. If something is missing, please contact PRL Customer Support.

3. Make sure to handle the air filter by the edges, as you can get some of the oil on your hands since they are pre-oiled filters.

4. To clean and apply oil, please reference the Filter Recharging section at the end of this guide.

5. You will need to unclip the MAF Sensor, loosen the factory corrugated hose and remove it, and remove the factory air-box fully.

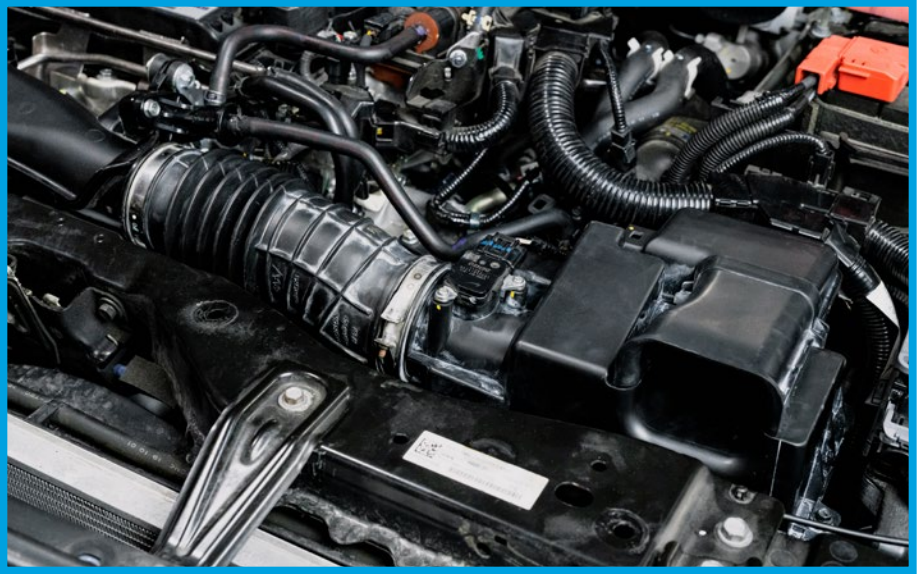

6. Pinch the back of the MAF sensor clip firmly and pull straight away from the MAF sensor housing. Be sure to not damage the sensor. Tuck it out of the way.



7. Remove the (2) factory clamps holding the corrugated hose to the factory air-box. This hose and clamps will not be re-used.



8. Remove the (2) Phillips head screws that holds the MAF sensor into the factory MAF housing. These screws will not be re-used.



9. Remove the MAF sensor fully from the factory airbox and place it into the PRL MAF housing. Using the supplied (2) M4 bolts and secure the sensor into place.



10. You will attach the intake bracket with the (2) M6 bolts. The spot to mount the bracket is located on the right side of the bay, near where the factory airbox was removed from the engine bay.

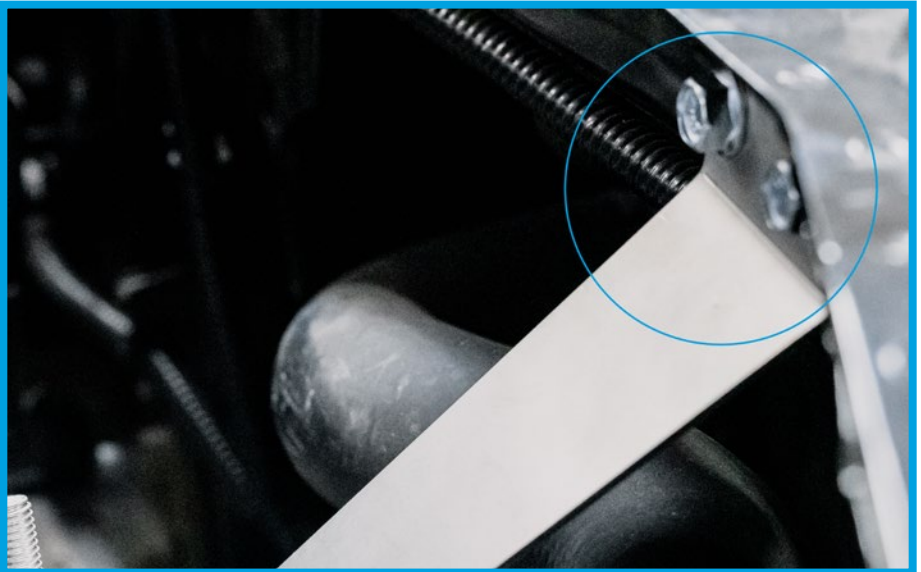

11. Insert the M8 Rubber Vibration Damper and tighten the Serrated Flange nut to the underside of the grommet to lock it in place



12. Seat the MAF housing with the onto the Rubber Vibration Damper so that it stays in the correct position.

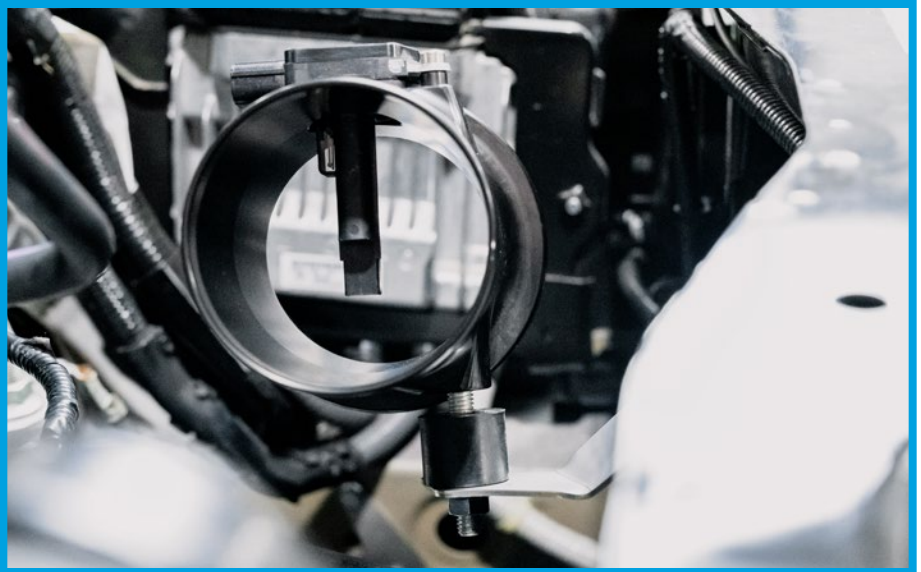

13. Affix the PRL 4" Cone Air Filter, as well as the PRL Silicone hose with the (2) provided worm gear clamps. Make sure they are tightly secured.



14. Re-clip the MAF sensor harness into place. Ensure that all clamps are tightened fully.



Road Testing Your PRL Short Ram Intake

1. Start the vehicle with the transmission in neutral and the emergency brake engaged. Assess to make sure of any possible issue(s) and then make any subsequent adjustments as they are needed.
2. Test drive the vehicle to ensure everything is in working order.
3. If after the road testing, everything is good to go, enjoy your PRL Stage 1 Intake! Thank you for being a part of the #PRLARMY.

If you have any questions/concerns please reach out to us at:
support@PRLMotorsports.com

Please provide a full description of your issue, ideally with any pertinent images or video clips that can help our team address the issue.

Please note: All support tickets are addressed during business hours and in order of received.

As stated at the beginning of this guide, the Short Ram Intake has been specifically designed to be 100% compatible with the factory ECU calibration. No tuning is required to benefit from the advertised gains and performance.

Required Maintenance

PRL Motorsports thoroughly recommends visually inspecting the air filter screen inside the HVI at every oil change. It is required to clean the air filter element whenever the screen is no longer visible or at a 30,000 mile interval. When used in a higher dust/arid climate or varied terrain environments, the air filter will require cleaning more often. To clean and re-oil, our #2801 Filter Cleaning & Recharge kits can be purchased direct on our website, or via an authorized PRL Motorsports dealer.

Filter Recharging Guide:

- 1. Pre-Cleaning:** Tap the filter or use canned air/compressor to remove any excess debris from the filter. Be careful to not damage the filter.
- 2. Apply Cleaner:** Spray the filter with the special cleaning solution provided in the kit and allow the solution to soak in for at least 15 minutes.
- 3. Rinsing:** Rinse the filter with warm water, clean side to dirty side to flush the dirt and debris outwards from the filter.
- 4. Drying:** Allow the filter to dry naturally. Try to avoid heat to prohibit any shrinkage that could occur in the cotton present in the filter.
- 5. Oil Application:** Re-oil the filter using the filter oil that is supplied in the kit. It is recommended to use a single spray per 2" of filter media. Do not over oil.



1400 RANDALL COURT - UNIT 104
EXPORT, PENNSYLVANIA 15632

www.PRLMotorsports.com

Follow Us!
PRLMotorsports

