



INTELLI Jay

12V POWER MANAGEMENT SYSTEM



PM235J Transformer Unit



Phone App



PMBTJ-02 Bluetooth Node
(PM235J-NODE system only)



PMLCD-BTJ LCD Screen
(PM200-BTJ system only)

P/No. PM200-BTJ & PM235J-NODE

Need technical help?
Contact Projecta on 1800 294 294

IMPORTANT SAFETY INFORMATION

Please read this manual thoroughly before use and store in a safe place for future reference.

WARNINGS

- Explosive gases. Prevent flames and sparks. Provide adequate ventilation during charging
- Before charging, read the instructions
- For indoor use. **Do not** expose to rain
- For charging Lead Acid and LiFePO₄ batteries **only** (of the size & voltage specified in the specification table.
- Always charge the battery on the correct voltage setting. Never set the charger to a higher voltage than the battery
- Disconnect the 240V mains supply before making or breaking the connections to the battery
- The battery charger must be plugged into an earthed socket outlet
- Connection to supply mains is to be in accordance with national wiring rules
- Do not attempt to charge non-rechargeable batteries
- Never charge a frozen battery
- If the AC cord is damaged, do not attempt to use. It must be replaced or repaired by a qualified technician
- Corrosive substances may escape from the battery during charging and damage delicate surfaces. Store and charge in a suitable area
- This charger is not intended for use by persons (including children) with reduced physical, sensory or mental capabilities, or lack of experience and knowledge, unless they have been given supervision or instruction concerning the use of the appliance by a person responsible for their safety
- Young children should be supervised to ensure that they do not play with the appliance
- If the recreational vehicle is to be put in to storage without power, please turn off the POWER SWITCH. If the recreational vehicle is to be put in to long term storage without power, disconnect ALL cabling from the battery.

CONTENTS

| | |
|---|-----------|
| 1. INTRODUCTION | 4 |
| 1.1 Features | 5 |
| 1.2 LCD monitor (PM200-BTJ only) | 6 |
| 1.3 Water tank probes | 6 |
| 2. KEY FEATURES AND FUNCTIONS | 6 |
| 2.1 Multiple inputs | 6 |
| 2.2 Battery charger of stationery/house battery | 6 |
| 2.3 Power supply mode | 7 |
| 2.4 PWM solar charger controller | 7 |
| 2.5 Voltage charging relay (VCR) | 7 |
| 2.6 Categorised outputs | 8 |
| 2.7 Battery low voltage protection | 8 |
| 2.8 Manual battery switch | 8 |
| 2.9 Precise battery measurement | 8 |
| 3. STRUCTURE AND INSTALLATION | 9 |
| 3.1 PM235J Transformer Unit | 9 |
| 3.2 LCD monitor (PM200-BTJ only) | 10 |
| 3.3 Water tank probes | 11 |
| 3.3.1 PMWS400 water tank probe | 11 |
| 3.3.2 PMWS200 water tank probe | 11 |
| 4. WIRING | 12 |
| 4.1 Material | 12 |
| 4.2 System schematic | 13 |
| 4.3 Preparation | 14 |
| 4.4 Connection | 14 |
| 5. DISPLAY | 15 |
| 5.1 PM235J Transformer Unit | 16 |
| 5.2 LCD monitor (PM200-BTJ only) | 16 |
| 5.2.1 Monitor symbol explanation | 16 |
| 5.2.2 Switch explanation | 17 |
| 5.2.3 Alphabet explanation | 17 |
| 6. OPERATION | 18 |
| 6.1 Configuration on PM235J Transformer Unit | 18 |
| 6.1.1 Load Remote Isolation Switch | 18 |
| 6.2 Configuration on monitor | 18 |
| 6.2.1 LCD Monitor configuration menu | 19 |
| 6.3 Connecting to a Smart Device (Bluetooth) | 20 |
| 6.4 Using the PM200-BTJ Remote App | 20 |
| 6.5 Maintenance | 21 |
| 6.5.1 Battery monitoring maintenance | 21 |
| 6.5.2 Daily maintenance | 21 |
| 7. TROUBLE SHOOTING | 21 |
| 7.1 L.E.D Display on PM235J Transformer Unit | 21 |
| 7.2 Error code on LCD Monitor | 21 |
| 8. SPECIFICATION | 22 |

1. INTRODUCTION

PM200-BTJ and PM235J-NODE are power management systems designed for use in caravans or motor homes. These systems allow for easy installation and a user-friendly interface.

Both PM200-BTJ and PM235J-NODE systems come with the same PM235J transformer unit, which the circuits in the caravan or motor home are centrally wired to. This transformer features built-in battery charger, power supply, fused distribution blocks, PWM solar charge controller, voltage charging relay (VSR), low voltage disconnect (LVD), water pump controller, hot water system controller, water tank indicator and battery monitoring.

The main difference between the two systems is that PM200-BTJ comes with an Bluetooth-enabled LCD screen (PMLCD-BTJ), allowing a user to monitor and control the system via the LCD or the Bluetooth app. PM235J-NODE does not come with an LCD screen, instead utilising a separate Bluetooth node (PMBTJ-02) to connect with the Bluetooth app.

SYSTEM COMPONENTS:

1. PM235J Transformer Unit
2. PMBTJ-02 Bluetooth Node (PM235J-NODE only)
3. PMLCD-BTJ (PM200-BTJ only)
4. Cables (Refer to Chapter 4 for the cable list)

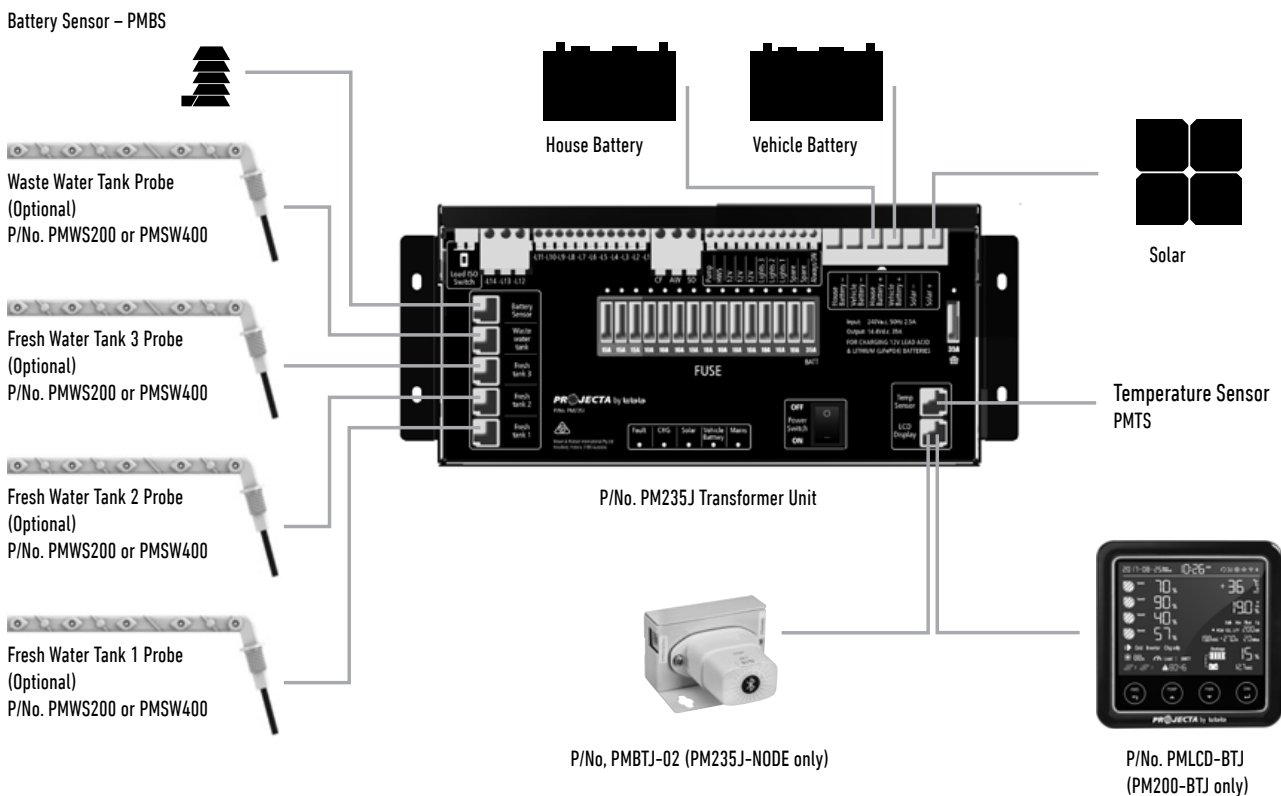

Figure 1 System Components for PM200-BTJ and PM235J-NODE

1.1 Features (PM200-BTJ and PM235J-NODE)

- Smart battery charger 12V 35A (30A for charging current)
- Multi stage adaptive charging algorithm
- Active Power Factor Correction (PFC) charging
- Temperature compensation charging
- Voltage compensation charging
- Solar charge controller (PWM), 30A
- 14 built in fused outputs
- Charging from Alternator at 12V 60A - 60A continuously, 100A 30mins
- Low battery voltage protection
- Built-in battery switch to isolate the battery when in storage
- Built-in shunt for precise battery measurement
- 1 water pump control with up to 4 connections for water sensors
- Thermal control fan
- Spring terminal and screw terminal
- T-bus compatible

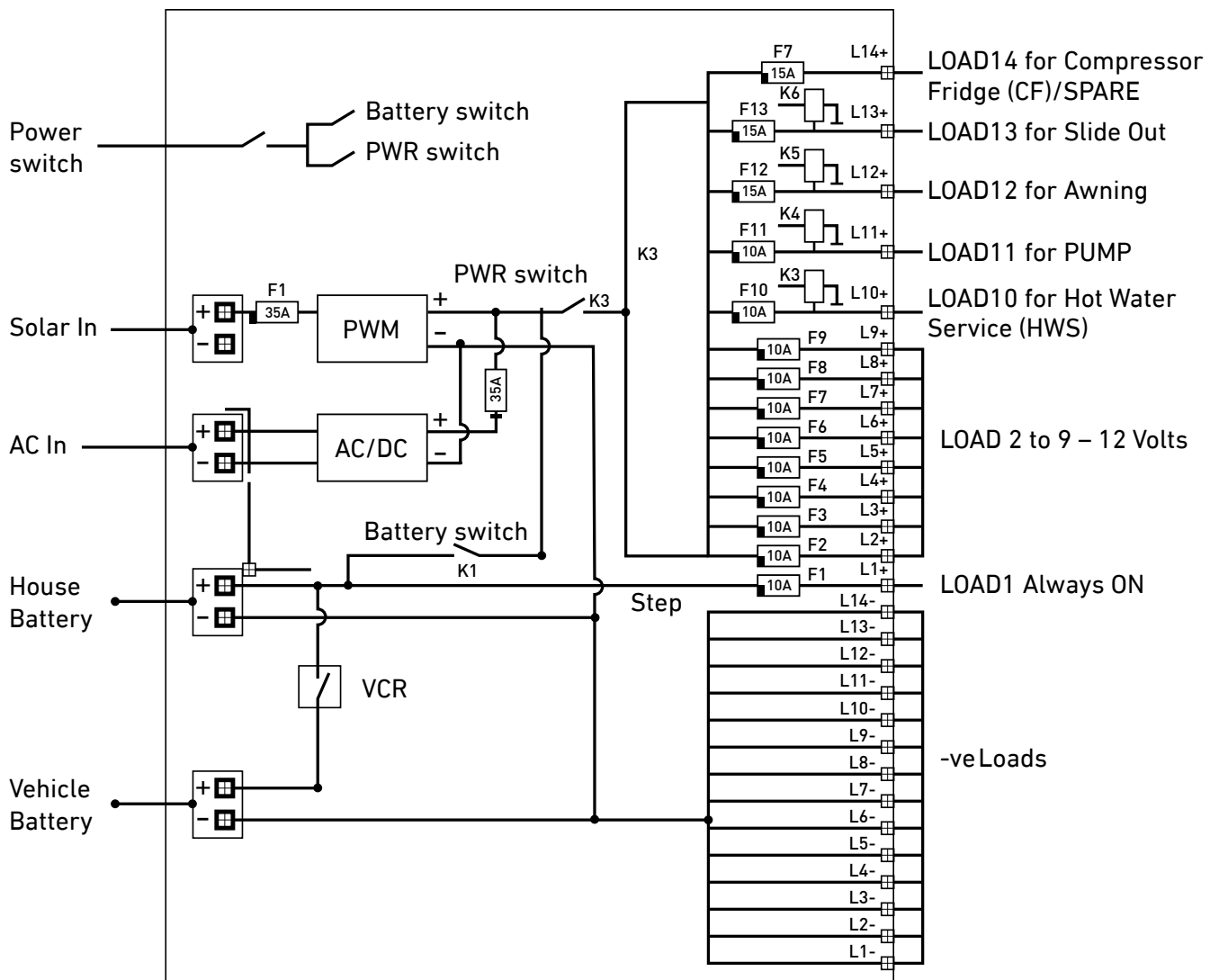

Figure 2 System Schematic

1.2 LCD Monitor PMLCD-BTJ (PM200-BTJ only)

The LCD monitor is a digital control center for the PM235J transformer unit. See section 5.2 for operation of LCD monitor.

FEATURES:

- T-Bus design (can be connected to multiple devices)
- System monitoring
- Configuration
- Built-in Bluetooth for pairing to smart phone



Figure 3 Overview of Monitor

1.3 Water Tank Probes

A maximum of up to 4 probes can be monitored by the system.

NOTE: Always check the probe required for the water tank before purchase.

There are 2 probe styles:

PMWS200:

- Side installation
- Suitable for water tank
- Depth >200mm

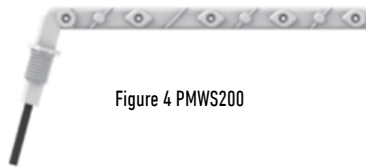

Figure 4 PMWS200

PMWS400:

- Side installation
- Suitable for water tank
- Depth 300-400mm

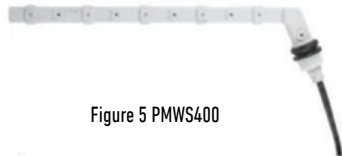

Figure 5 PMWS400

2. KEY FEATURES AND FUNCTIONS

2.1 Multiple Inputs

The PM235J transformer unit accepts inputs from AC mains, solar panel and vehicle battery. However, see Table 1 at right for details.

| | | | |
|-------------------|----------|----------|---------|
| AC MAINS | X | X | |
| SOLAR | X | | X |
| VEHICLE BATTERY | | X | X |
| DOMINATING SOURCE | AC MAINS | AC MAINS | COMBINE |

Table 1 Multiple inputs

2.2 Battery Charger Of House Battery

The charger automatically starts when the appropriate qualified power is connected, either from AC mains, alternator or solar.

With multiple charging stages (soft start-bulk absorption float-charge), PM235J is designed to fully charge a battery quickly. To guarantee the optimal charging for batteries of different states, the PM235J features a Microprocessor-controlled charging algorithm. The Float and Recycle charging programs guarantees that the battery condition does not change despite being connected for a longer period.

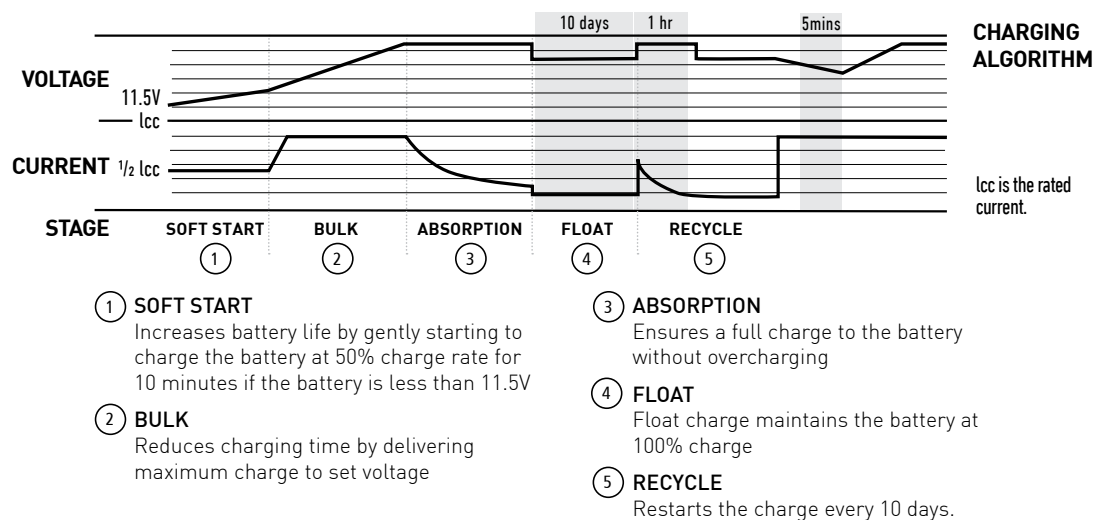

Figure 6 Charging Algorithm

Battery Temperature Sensor

The PMBS (battery sensor cable) is connected to measure the temperature of the battery and automatically adjusts, in real time, to charge the battery properly at compensation rate of $-4\text{mV}\pm 10\%/^{\circ}\text{C}/\text{cell}$. In case PMBS is not present, the PM235J will use 25°C as default.

Voltage Compensation Charging

With a voltage sensor the PM235J can automatically adjust its output to compensate the voltage drop caused by a cable. This assures the right voltage is being delivered for optimal charging.

Adjustable Charging Capacity

Users can adjust the charging current by specifying the battery capacity. The charging current is set at threshold rate of 15% the of the battery capacity ($I = 0.15C$) by default.

Lithium Battery Charging

The PM235J can be configured to charge a lithium battery. With a lithium battery, the max charging current will automatically be set at 30% of battery capacity ($I_{\text{max}}=0.3C$).

2.3 Power Supply Mode

If no battery is attached to PM235J unit, it will work as a power supply automatically with a 12.8VDC output.

2.4 PWM Solar Charger Controller

PM235J has a built-in PWM charger for the house battery with:

- Max input voltage 25VDC
- Max charging current 30A

2.5 Voltage Charging Relay (VCR or commonly known as a VSR)

As a Safety feature, the Slide Out (+L12) and Awning (L13) outputs are disabled when towing vehicle is connected to the Caravan (and vehicle battery voltage is detected at $>5\text{V}$). To enable these outputs again, disconnect the vehicle's power plug from the caravan. If the VCR is still engaged, press the PWR button on the LCD or app ON / OFF / ON.

LEAD ACID BATTERY – When the vehicle battery reaches 13.4VDC with threshold time delay, the VCR will charge the house battery from the alternator. The VCR will continue the charging until the vehicle battery voltage drops under 12.8VDC.

LiFePO4 LITHIUM BATTERY – When the vehicle battery reaches 13.7VDC with threshold time delay, the VCR will charge the house battery from the alternator. The VCR will continue charging until the vehicle battery voltage drops below 13.3VDC with less than 2A charge to the house battery with threshold time delay.

NOTE: The PM235J, when charging from the vehicle battery, does not provide the 5 stage charge. It simply takes whatever power and charging is available from the alternator.

NOTE: If your vehicle is fitted with a smart alternator, the VCR charge system (Variable Voltage or Temperature Compensating), the VCR charge system may not function correctly and a Projecta IDC25 charging system is recommended.

Please contact Projecta for further information.

2.6 Categorised Outputs

The 14 outputs are categorised into groups and controls as per below:

| OUTPUTS | DESCRIPTION | POSSIBLE LOAD SUITABLE |
|---------|--|---|
| 4 | Relay controlled output with fuse, protected by main master switch relay | Awning, Slide Out, Hot Water System (HWS), Pump |
| 9 | Fused outputs, protected by master switch relay | Lights, ventilation fan, TV etc. |
| 1 | Always ON | Auto step, radio/clock memory etc. |

Table 2 Categorised outputs

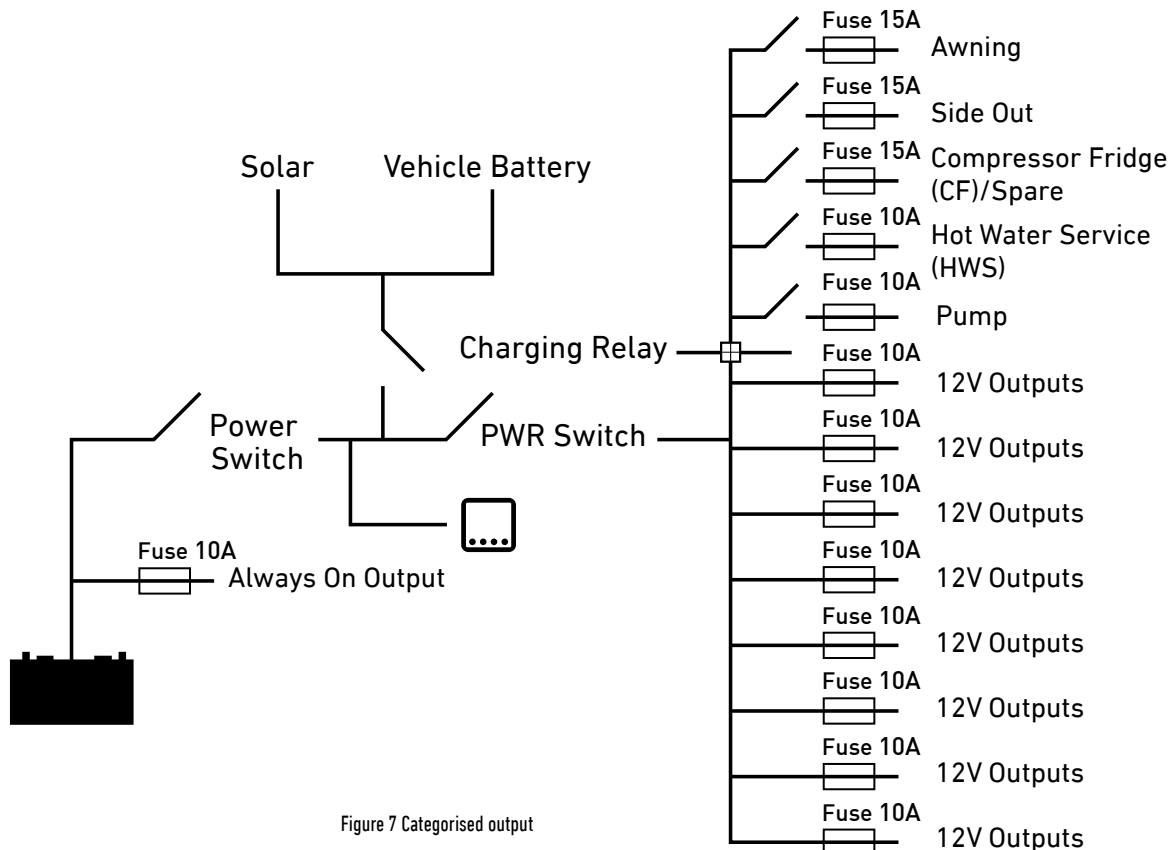

Figure 7 Categorised output

2.7 Battery Low Voltage Protection (BLVP or commonly known as an LVD)

The PM235J transformer unit has a built-in low voltage protection relay. It will disconnect the load once the battery voltage drops below the threshold voltage. The default setting is 10.5VDC.

2.8 Power Switch

The PM235J transformer unit offers a convenient way to cut off charger and switch off the outputs of the House Battery. It protects the House Battery from being drained by the on board electronics, completely isolating the battery, perfect for storage. This switch is located on the front face of the PM235J transformer unit.

2.9 Precise Battery Measurement

The PM235J transformer unit has a battery measurement system controlled by microprocessor. It measures battery voltage, charge/discharge current, remaining Amp-hours and display time to go.

Compared to conventional indicating meters, a small current can be measured and read accurately with this device. With this feature, it highlights faults, alarms and installation errors.

NOTE: If you have loads connected directly to the battery instead of through the PM235J transformer unit, the measurement will not be accurate.

3. STRUCTURE AND INSTALLATION

3.1 PM200-BTJ and PM235J-NODE Power Management Systems

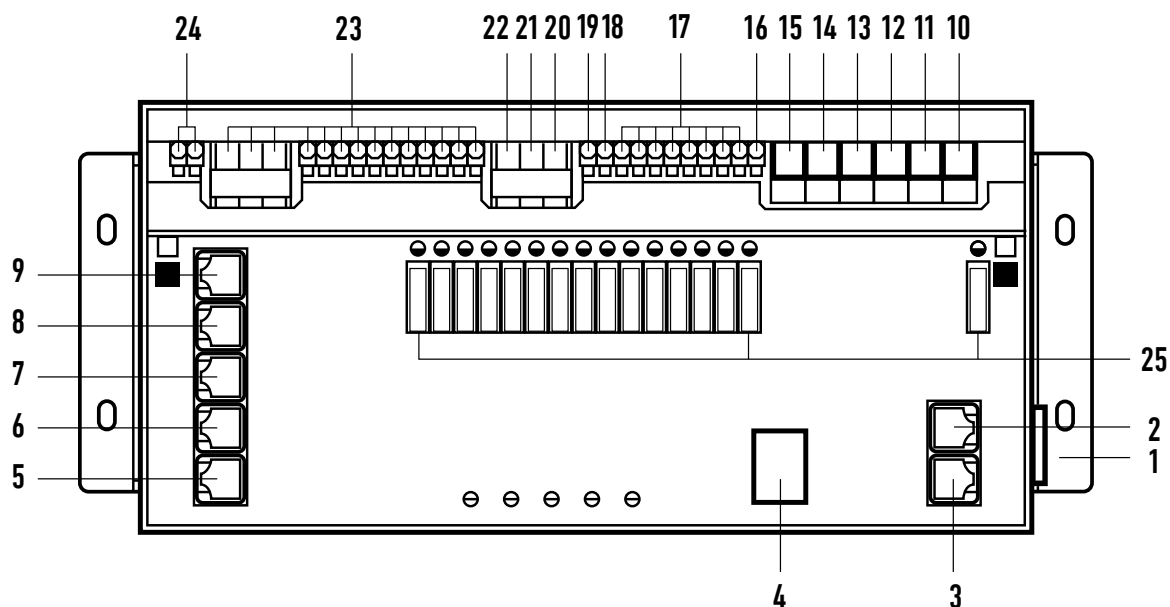

Figure 8 Front panel of PM235J Transformer Unit

| Nº | LABEL | DEFINITION | DESCRIPTION |
|----|--------------------|----------------------------------|---------------------------------------|
| 1 | AC Mains | AC input port | Computer/IEC style plug socket |
| 2 | Temp Sensor | Comm port | Temperature Sensor input |
| 3 | LCD Display | Comm port | Connect to Monitor |
| 4 | Power switch | Charger and house battery switch | Manual battery switch |
| 5 | Fresh water tank 1 | | Connect to fresh water tank 1 |
| 6 | Fresh water tank 2 | | Connect to fresh water tank 2 |
| 7 | Tap water tank 3 | | Connect to tap water tank |
| 8 | Waste water tank 4 | | Connect to waste water tank |
| 9 | House Sensor | For temp compensation | Connect to house battery |
| 10 | Solar+ | Solar input | Connect to solar panel + terminal |
| 11 | Solar- | Solar input | Connect to solar panel - terminal |
| 12 | Vehicle Bat+ | Vehicle battery+ | Connect to vehicle battery+ (<20Vdc) |
| 13 | House Bat+ | House battery+ | Connect to house battery+ (<20Vdc) |
| 14 | Vehicle Bat- | Vehicle battery- | Connect to vehicle battery- |
| 15 | House Bat- | House battery- | Connect to house battery- |
| 16 | L1+ | Always ON | Connect to permanent +12 Volts |
| 17 | L2+ ~ L9+ | | Connect to isolating +12 Volts |
| 18 | L10+ | HWS (Hot Water System) | Connect to HWS+ |
| 19 | L11+ | Water pump | Connect to water pump+ |
| 20 | L12+ | Slide out | Connect to slide out+ |
| 21 | L13+ | Awning | Connect to awning+ |
| 22 | L14+ | Spare/CF (Fridge) | Connect to CF+ |
| 23 | L1- ~ L14- | | Connect to DC load- |
| 24 | Remote ISO Switch | Terminal block | Connect to external switch (optional) |
| 25 | Fuse | | Fuse and fuse failure indication |

Table 3 Categorized outputs

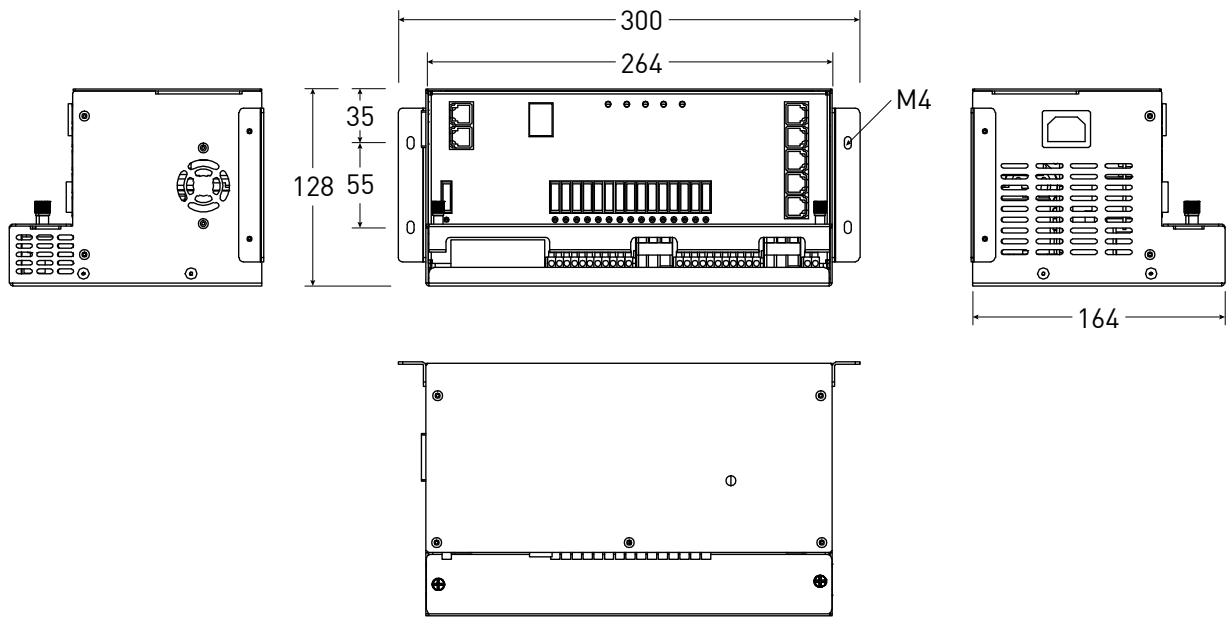

Figure 9 Dimension of PM235J (Unit: mm)

Installation:

PM235J can be installed on a horizontal surface or vertically on a wall. Please see following instructions:

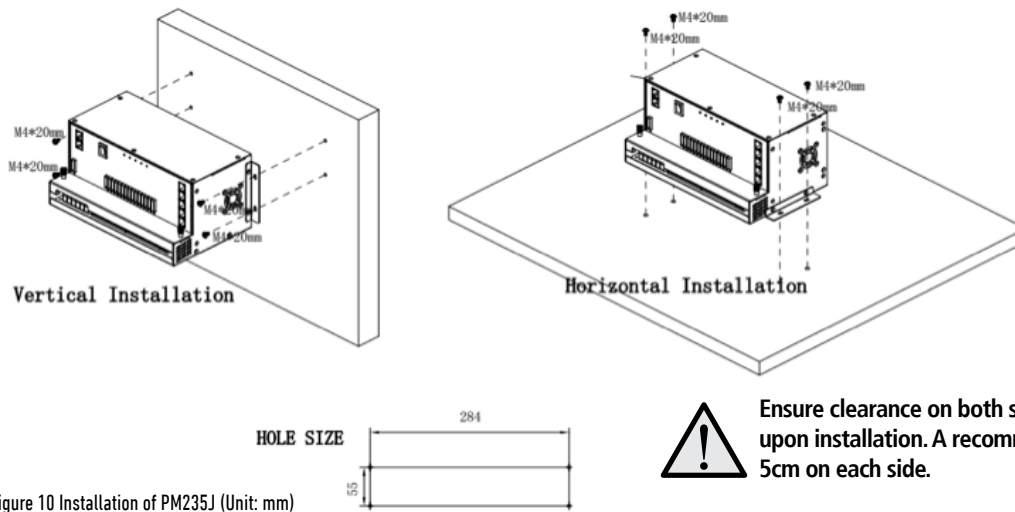

Figure 10 Installation of PM235J (Unit: mm)

3.2 LCD Monitor (PM200-BTJ only)

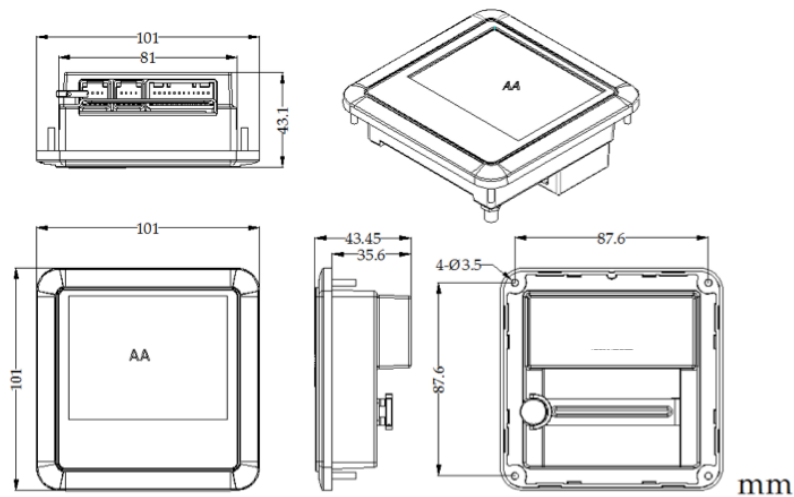

Figure 11 Dimension of Monitor PMLCD-BTJ (Unit:mm)

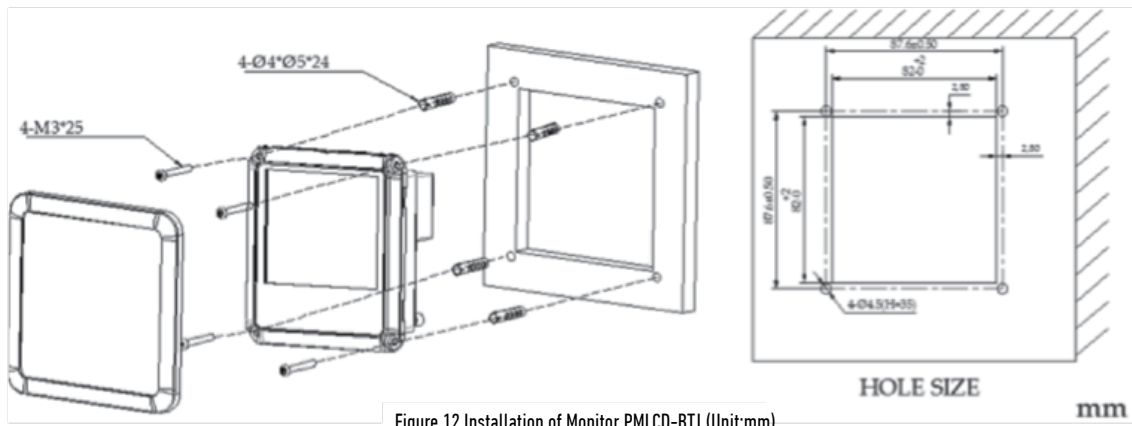

Figure 12 Installation of Monitor PMLCD-BTJ (Unit:mm)

3.3 Water Tank Probes

3.3.1 PMWS400 Water Tank Probe

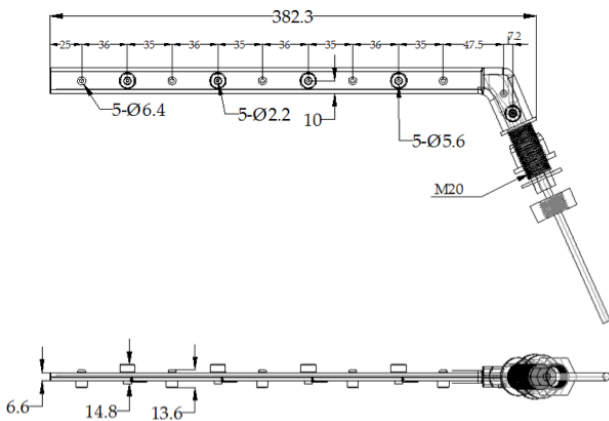

Figure 13 Dimension of PMWS400 (Unit:mm)

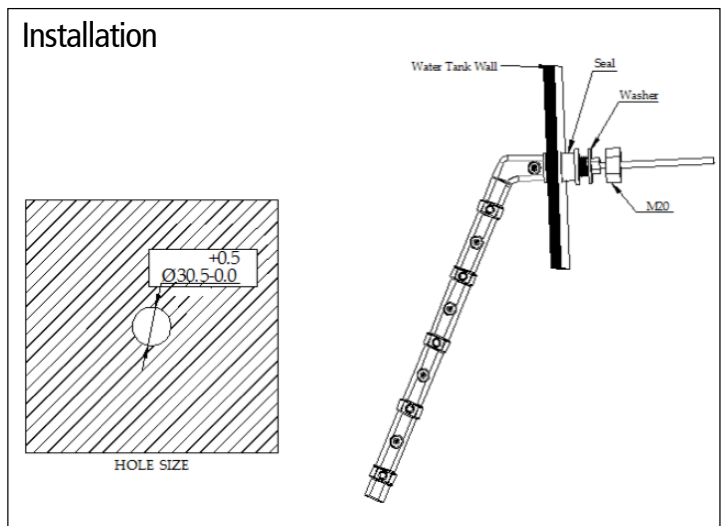

Figure 14 Installation of PMWS400

3.3.2 PMWS200 Water Tank Probe

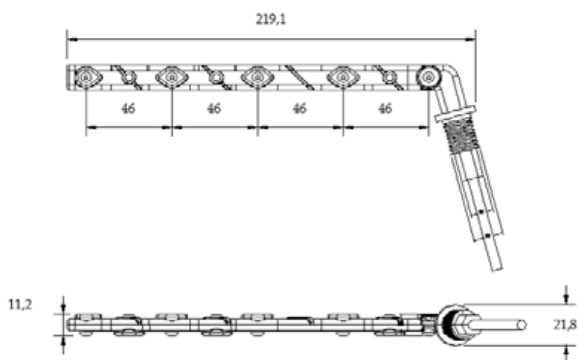

Figure 15 Dimension of PMWS200 (Unit:mm)

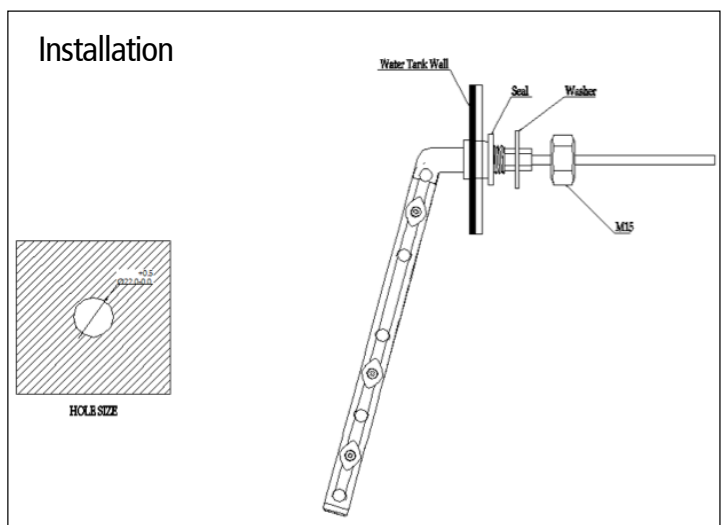

Figure 16 Installation of PMWS200

4. WIRING

4.1 Material

| CODE | NAME | MODEL/ LENGTH | QTY | P/No. ON DRAWING |
|------|---------------------------------|---|-----|-------------------|
| 1 | Transformer Unit | PM235J | 1 | 1 |
| 2 | LCD Monitor | PMLCD-BTJ | 1 | 2 |
| 3 | Fresh water tank 1 level sensor | Not included and to be ordered separately | 0 | 4 |
| 4 | Fresh water tank 1 level sensor | | 0 | 5 |
| 5 | Tap water tank level sensor | | 0 | 6 |
| 6 | Waste water tank level sensor | | 0 | 7 |
| 7 | Solar | | 0 | 9 |
| 10 | Communication line (RS485) | 10m | 1 | PMLCDC-10 |
| 11 | Temperature line | 5m | 1 | PMTS |
| 12 | Battery sensor line | 3m | 1 | PMBS |
| 13 | Water tank probe line | Not included | 0 | PMWS200 / PMWS400 |
| 14 | Water tank probe line | | 0 | |
| 15 | Water tank probe line | | 0 | |
| 16 | Water tank probe line | | 0 | |
| 17 | Power Cable | 1.5m | 1 | PMAC |

Table 4 Component List of PM200-BTJ

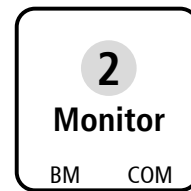

PMLCDC

AC in
240V / 50Hz
~

L
N

PMAC



House Battery -
House Battery +

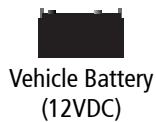

Vehicle Battery -
Vehicle Battery +



Solar in
Vmp: 17-25V

Solar-
Solar+

9 Solar

4.2 System Schematic

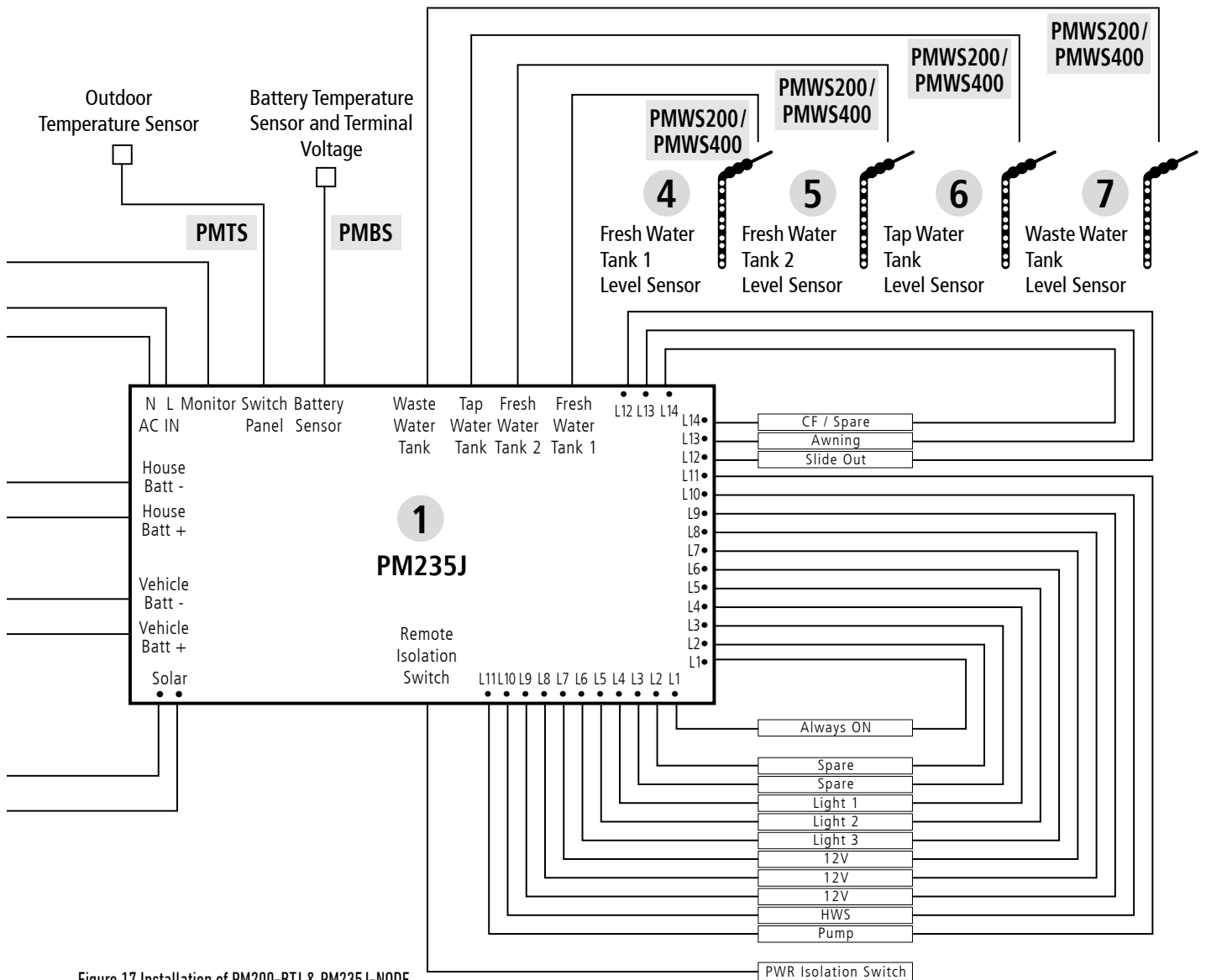

Figure 17 Installation of PM200-BTJ & PM235J-NODE

4.3 Preparation

PM200-BTJ and PM235J-NODE systems are designed with the concept of 'Plug in and Play' in mind. To complete the easy installation, a screw driver and DC cables are required. Follow Table 5 recommendation for minimum wiring size.

| CURRENT | MINIMUM CABLE SIZE |
|---------|------------------------------|
| 0–5A | 1.0mm ² or 18 AWG |
| 5–10A | 2.0mm ² or 14 AWG |
| 10–15A | 3.0mm ² or 13 AWG |
| 15–20A | 4.0mm ² or 11 AWG |
| 20–25A | 5.0mm ² or 10 AWG |
| 25–30A | 6.0mm ² or 9 AWG |



When running cables, if they pass through panels or wall, ensure the cables are protected from damage by sharp edges. In such cases, it is recommended to use cable glands.

Table 5 Minimum cable size

4.4 Connection

PM235J transformer unit is designed with a spring and screw terminal. Please refer to following illustration at right. Each type of terminal is designed to fit a different range of cables.

| TYPE | TERMINAL MODEL NUMBER | SUITABLE CABLE GAUGE |
|--------|-----------------------|--|
| Type 1 | ERTB10-10.16 | 0.5mm ² – 10mm ² |
| Type 2 | Wago804-114 | 0.25mm ² – 2.5mm ² |
| Type 3 | Wago2704-103 | 0.5mm ² – 6mm ² |

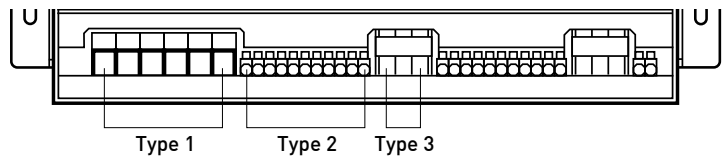

Table 6 Recommended terminal and cable gauge

Figure 18 PM235J Terminals

TYPE 1

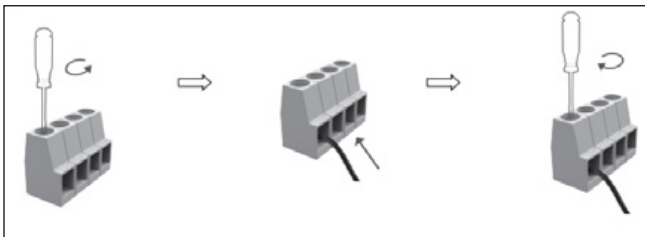

Figure 19 Connection of Terminal Type 1

TYPE 3



Figure 21 Connection of Terminal Type 3

TYPE 2

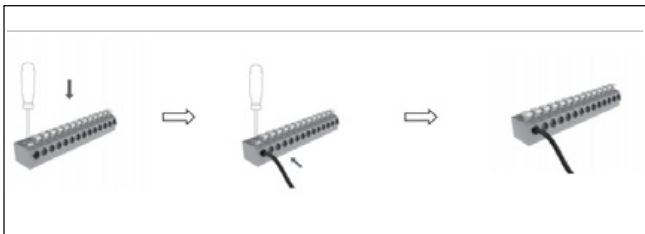

Figure 20 Connection of Terminal Type 2

5. DISPLAY

5.1 PM235J Transformer Unit

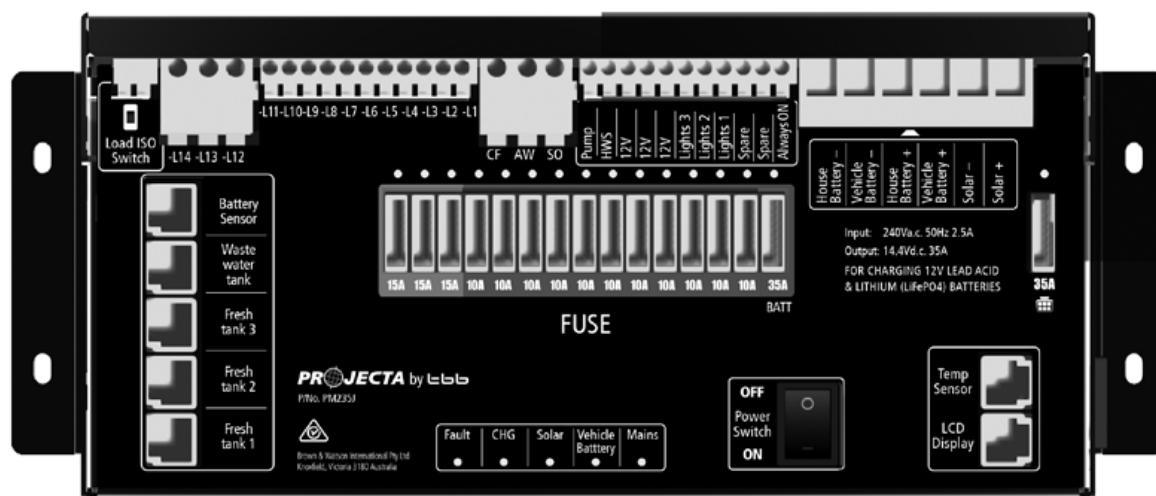

Figure 22 An overview of PM235J

| No. | LED | COLOUR | STATUS | DESCRIPTION |
|-----|-------------|--------|---|---|
| 1 | Mains | GREEN | ON | AC input OK |
| | | | OFF | AC disconnected |
| | | | Quick flashing (flash twice every second) | AC input abnormal |
| 2 | Vehicle Bat | GREEN | ON | Alternator charging the house battery |
| | | | Slow flashing (flash once every second) | Vehicle battery is >13.4V and is being charged by the AC |
| | | | Quick flashing (flash twice every second) | The vehicle battery is 2~13.4V or >16.0V, while AC power is connected. |
| | | | OFF | Vehicle battery is disconnected. |
| 3 | Solar | GREEN | ON | Solar charging the battery |
| | | | Slow flashing (flash once every second) | The input voltage of the Solar is normal but it is charged by the AC or vehicle battery |
| | | | Quick flashing (flash twice every second) | Solar input voltage error – Solar voltage >25Vdc |
| | | | OFF | Solar disconnected |
| 4 | CHG | GREEN | ON | Battery charged |
| | | | Slow flashing (flash once every second) | Battery charging |
| | | | Quick flashing (flash twice every second) | Battery discharge |
| | | | OFF | Battery disconnected |
| 5 | FAULT | RED | ON | Short circuit |
| | | | Flash once per cycle | House battery voltage low |
| | | | Flash twice per cycle | House battery voltage high |
| | | | Flash 3 times per cycle | PM235J unit Over Temperature |
| | | | Flash 4 times per cycle | Bulk charge timeout |
| | | | Flash 5 times per cycle | VCR anomaly |
| | | | Flash 6 times per cycle | Environment Over Temperature |

Table 7 LED indicator description of PM235J

5.2 LCD Monitor (PM200-BTJ only)



Figure 23 An overview of monitor

The PMLCD-BTJ monitor can be paired to a smart phone via the smart device app. This app will display the battery parameters, water tank levels, allow pump control and power isolation. Refer to section 6.3 for the Bluetooth pairing procedure.

5.2.1 LCD Monitor Symbol Explanation











| No. | DESCRIPTION | COMMENTS | |
|-----|------------------|---|--|
| 1 | Water level | 0%-25%-50%-75%-100% | |
| | Water Tank 1 | EMPTY | |
| | Water Tank 2 | | |
| | Water Tank 3 | | |
| | Water Tank 4 | FULL | Flashing, the gray water or waste water is more than the alarm level |
| 2 | Working Mode | MAINS | AC mains status |
| | | CHARGE ONLY | Battery charger only |
| 3 | Power |  | Status of DC-Load switch in system: on / off |
| | | BATTERY | DC loads are powered by battery |
| 4 | Water Pump |  | Pump 1 is ON |
| | |  | Pump 1 is OFF |
| 5 | Alarm Error Code |  | Overload alarm |
| | |  | Over temperature alarm |
| | |  | System error code. Refer to the error codes on page 20 |
| 6 | VCR connection |  | Voltage charging relay (VCR) is connected |
| | |  | Voltage charging relay (VCR) is disconnected |
| 7 | Output power |  | Voltage of system output |
| | |  | Current of system output |

Table 8 Symbol Explanation

5.2.2 LCD Monitor Switch Explanation

| SWITCH | FUNCTION | DESCRIPTION |
|------------------|--|---|
| HWS | To switch on/off Hot Water Service | HWS on: HWS off (Appears in top left of screen for 10 seconds) |
| PUMP | To switch on/off pump | Refer Figure 24 |
| PWR | To switch off all the loads connected on DC charger | Refer Figure 25 |
| DIM | To adjust the brightness and switch off the backlight of the monitor | Total three levels of brightness |
| DIM Hold (5 sec) | To set clock, battery battery tank quantity etc | Hold down the 'LIGHT' button until the Date zone (Table 16) shows the setting code. It means the unit enters the setting mode. For the full details of setting codes, please refer to Chapter 6.2.1 |

Table 9 Switch Explanation



Figure 24 Switch ON /OFF Pump



Figure 25 Switch ON /OFF all of the DC Loads

5.2.3 Alphabet Explanation

| | | | | | | | | | | | | | | | | | | | | | | | | | |
|-----------|---|---|---|---|---|---|---|---|---|---|---|---|---|---|---|---|---|---|---|---|---|---|---|---|---|
| CHARACTER | A | B | C | D | E | F | G | H | I | J | K | L | M | N | O | P | Q | R | S | T | U | V | W | X | Y |
| ALPHABET | A | B | C | D | E | F | G | H | I | J | K | L | M | N | O | P | Q | R | S | T | U | V | W | X | Y |

Table 10 Alphabet code

6. OPERATION

6.1 Configuration on PM235J

Configuration of the battery type and capacity can be done through the LCD Monitor or the smart device app.

6.1.1 Load Remote Isolation Switch

This function allows for the use of a remote ISO switch to turn ON/OFF the L2-L14 outputs.

6.2 Configuration on LCD Monitor

Access to the configuration menu is safeguarded with a passcode. The default is 0000 and may be set by a user.

Passcode Descriptions

| | |
|------|------------------------------|
| 0000 | Factory Default, no passcode |
| 1999 | Factory access passcode |
| XXXX | User define |

Press the 'DIM' button until the setting code is showing on the date time area which means the monitor is ready for configuration. The 'PUMP' button and 'PWR' button can be used to scroll through the configuration menu.

| CODE | FUNCTION | DESCRIPTION |
|-----------|--------------------------|---|
| CLOC | Time Setting | Set date system 12H/24H and date. |
| BATE | Battery Setting | |
| | TYPE | Battery Type AGM / GEL / LFP (LiFePO ₄)/WET |
| | CAPA | Battery Capacity |
| | BLVP | Battery Low Voltage Protection To shutdown the output of loads |
| FACTRY | Restore factory defaults | |
| | CANCEL | Cancel Cancel to restore factory defaults |
| | ACCEPT | Accept Confirm to restore factory defaults |
| VER | Version | Software version of devices. read only |
| | CMP | CMP Software Version of PM235J |
| | LCD | LCD Software Version of PMLCD-BTJ |
| UPDATE EN | Update enable | Enable to update firmware |

Table 16 Setting code of the Monitor

6.2.1 LCD Monitor Configuration Menu

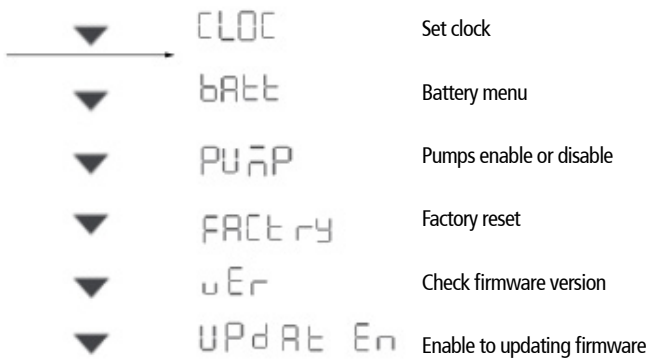

Figure 26 Main menu of setting

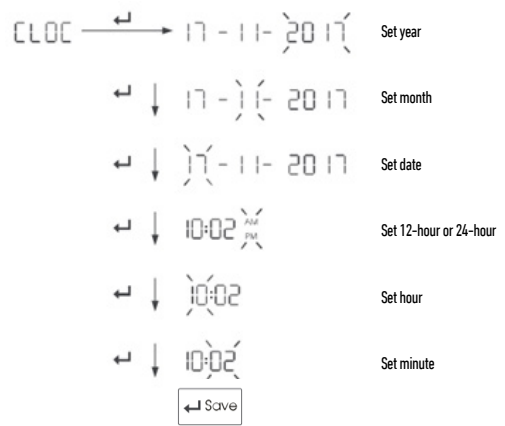

Figure 27 Date and Time setting



Figure 28 Battery Type setting

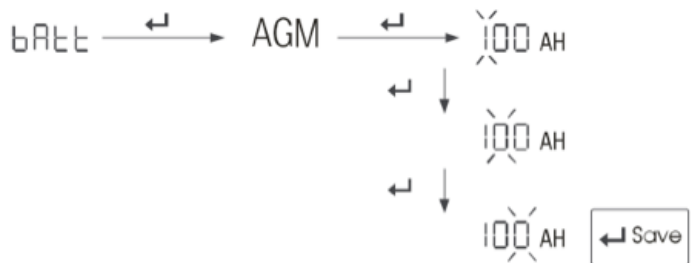

Figure 29 Battery Capacity setting



Figure 30 Low Voltage Protection setting



Figure 31 Restore factory setting

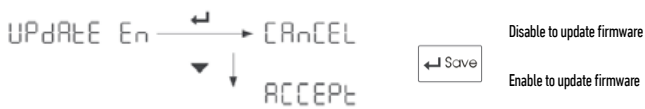

Figure 32 Update firmware



Figure 33 Check firmware version

6.3 Connecting to a Smart Device (Bluetooth)

1. Go to your smart device's App Store (iPhone/iPad) or Play Store (Android) and search for the Jayco "IntelliJay PM200-BTJ" app. Download this app to your smart device.
2. Ensure Bluetooth is enabled on your smart device and that permission is granted for the app to use Bluetooth and discover new connections.
3. Open the app and it will begin searching for either your PMLCD-BTJ LCD monitor (for PM200-BTJ systems), or your PMBTJ-02 Bluetooth node (for PM235J-NODE systems). When it shows up in the device list, tap and you will be prompted to enter a pairing code.
4. This pairing code will be displayed on the LCD monitor/screen of PM200-BTJ systems. For PM235-NODE systems, the pairing code is the last 4 digits of the serial number located on the side of the PMBTJ-02 Bluetooth node. Enter this code on your smart device and confirm.

If your system does not show up in the device list, ensure the following:

- You are within close enough proximity to the LCD monitor or Bluetooth node.
- The LCD monitor or Bluetooth node is properly connected to the PM235J transformer and operational
- Your smart device operating system is up to date (iOS 8.0 and higher, or Android 4.4 and higher)

6.4 Using the PM200-BTJ Remote App

1. Once you have established a paired connection with your smart device, the app will take you to its home screen where you may see a variety of system parameters.
2. It is now important to select your battery type, to ensure ideal charging and system operation. To do this, tap the white settings cog/gear down the bottom of the screen. Note: depending on your device, you may need to scroll to reveal this menu. Tap the down arrow under "Type". Choose your battery type from the list – AGM, GEL, LFP (lithium) or WET. Next, it is important to set your battery capacity in amp hours (Ah). You can find this information printed on your battery. Tap the right arrow under "Capacity" to specify your battery capacity.
3. It is also recommended that you update your PM200-BTJ or PM235J-NODE system to the latest firmware – this can be done by via the update function in the settings menu (your system may already be up to date). Please ensure you remain in close proximity to the system and do not disconnect power to the system or your phone during an update.
4. From the home screen, the PM200-BTJ app allows the user to remotely monitor key aspects of the power system from the convenience of their phone or tablet, as well as remotely switch on or off power to the output load, hot water system and water pump.

The following information is displayed in the app's home screen:

- House battery SOC, volts, amps, time remaining and temperature
- Vehicle battery voltage
- Charging mode/status
- Power input source (grid, solar/PV or VCR)
- Water tank levels (when sensors connected/installed/operational)
- Load, hot water system and water pump status and power buttons

The power button may be used to turn output load power on or off, resulting in startup or shutdown of all appliances and lighting wired to outputs on the PM235J transformer.

NOTE: This switch only affects output load – the app will continue monitoring parameters and retain its Bluetooth connection to your smart device, even with the load off.

6.5 MAINTENANCE

6.5.1 Battery SOC Monitoring

The PM235J transformer unit features built-in state of charge (SOC) monitoring for the house battery. To ensure accurate display of this information on the LCD monitor and in the app, the following conditions must be adhered to:

1. Battery capacity is set correctly in the LCD or app – refer to your battery specifications.
2. When replacing a battery, ensure it is fully charged via AC mains for the first time.
3. Fully charge battery via AC mains at least once every 3 months, until the 'CHG' LED light on the PM235J transformer unit remains on (solid) or 'float' shows on the monitor.

6.5.2 DAILY MAINTENANCE

- Ensure the Power Switch on the transformer unit is ON when you want to charge the battery with AC mains.
- Check the nominal battery voltage is 12VDC.
- Ensure there is space (10cm each side) beside the PM235J unit for the appropriate ventilation.

7. TROUBLE SHOOTING

7.1 L.E.D Display on PM235J Transformer Unit

| No. | LED | COLOUR | STATUS | DESCRIPTION |
|-----|-------------|--------|--|--|
| 1 | Mains | Green | Quick flashing (flash twice every second) | AC input abnormal |
| 2 | Vehicle Bat | Green | Quick flashing (flash twice every second) | The vehicle battery is 2~13.4V or >16.0V, while AC power is connected. |
| 3 | Solar | Green | Quick flashing (flash twice every second) | Solar input voltage error – Solar Input >25Vdc |
| 4 | Fuse LED | Red | Solid | Fuse blown, need to check load and replace fuse |
| 5 | Fault | Red | ON | Short circuit |
| | | | Flash once per cycle | House battery voltage low |
| | | | Flash twice per cycle | House battery voltage high |
| | | | Flash 3 times per cycle | PM235J unit over temp |
| | | | Flash 4 times per cycle | Bulk charge timeout |
| | | | Flash 5 times per cycle | VCR anomaly |
| | | | Flash 6 times per cycle | Environment over temp |

Table 17 Error LED indicator of PM235J

7.2 Error Code on LCD Monitor

| ERROR CODE | DESCRIPTION |
|------------|-----------------------------|
| 8001 | Lose communication |
| 8003 | Loss of communication |
| 8004 | Battery voltage high |
| 8005 | Solar voltage low |
| 8006 | Solar voltage high |
| 8010 | Battery temperature high |
| 8011 | Battery temperature low |
| 8012 | Internal temperature high |
| 8013 | Vehicle battery voltage low |

| ERROR CODE | DESCRIPTION |
|------------|---------------------------------|
| 8014 | Vehicle battery voltage high |
| 8015 | Over load |
| 8016 | Output short circuit |
| 8017 | Module protection |
| 8018 | Battery maintenance notice |
| 8027 | VCR connect is error |
| 8028 | VCR disconnect error |
| 8030 | Environment temperature is high |
| 8031 | Bulk stage time-out |

Table 18 Error Code List

8. SPECIFICATION

| MODEL | | PM235J |
|----------------------------------|-------------------------------|---|
| ELECTRICAL SPECIFICATIONS | | |
| Mains | Nominal input voltage (V) | 240±10%VAC 50/60Hz |
| | Power factor | 0.95 |
| | Input current at full load | 2.5A |
| Battery | Vehicle battery | 12VDC |
| | Vehicle battery voltage range | 12.8-16VDC |
| | House battery | 12VDC |
| | House battery voltage range | 10.5-16VDC |
| Solar | Charger type | PWM |
| | Open circuit voltage | 25VDC |
| | Max charging current | 30A |
| | Maxium solar input | 800W |
| Charging Relay | Relay specification | 12VDC 60A continuous, peak current 100A, 30mins |
| | Connect voltage | Lead Acid - 13.4VDC LiFePO ₄ - 13.7VDC |
| | Connect delay time | 10sec |
| | Disconnect voltage | Lead Acid - 12.8VDC LiFePO ₄ - 13.3VDC<2A |
| | Disconnect delay time | 60sec |
| | High voltage limit | 16.0VDC |
| Charger Mode | Charge Algorithms | 5 Stage |
| | Battery type | AGM/GEL/LFP (LiFePO ₄)/WET |
| | Start voltage | 2V for Lead Acid 0V for LFP |
| | Bulk current | 30A (Max) |
| | Absorption voltage | (14.4/14.1 /14.4/14.7) ±0.15VDC |
| | Float voltage | (13.5/13.5 /13.5/13.7) ±0.13VDC |
| Power Supply Mode | Nominal output voltage | 12.8±0.2 VDC |
| | Rated output current | 35A (Continuous) |
| Efficiency | | 88% |
| Working temperature | | -40°C~+65°C (50°C:full load; 60°C:20A; 65°C: shutdown the output) |

| MODEL | | PM235J | |
|----------------------------------|--|--|--------------------|
| ELECTRICAL SPECIFICATIONS | | | |
| Battery Disconnect (LVD) | Disconnect voltage | AGM/GEL/WET | 10.5VDC (default) |
| | | LFP (LiFePO ₄) | 11.2 VDC (Default) |
| | Delay off time | 60 sec | |
| | Reconnect voltage | AGM/GEL/WET | 11.5VDC (default) |
| LFP (LiFePO ₄) | | 12.2 VDC (Default) | |
| Current draw on Battery | 240VAC is off, no vehicle charging | 330mA | |
| | Load switch off | 255mA | |
| | LVD off, Service<10.5V current draw on battery | 180mA | |
| | Battery switch OFF <10V draw on battery | 0mA | |
| Fused outputs | Numbers | 14 | |
| | Rated Current | 10A x 11, 15A x 3 | |
| Protection | Short circuit on output | Fuse blown | |
| | Reverse polarity | Diode reverse isolation | |
| | Overload protection | Derate the output until overload is removed | |
| | Battery charger over temperature | Shut down PM235J | |
| | Ambient over temperature | Alarm | |
| | Battery over voltage limits | Battery charger disconnect, loads disconnect | |
| PHYSICAL SPECIFICATIONS | | | |
| Dimensions (L*W*H) | 264 × 164 × 128mm | | |
| Weight | 3kgs | | |
| Enclosure | Steel Case | | |
| Battery Connector | M4 Screw (16mm ²) | | |
| Load Connector | Wago804-114 (2.5mm ²) | Wago2706-103 (6mm ²) | |
| Cooling | Forced cooling | | |
| Protection category | IP20 | | |
| Approvals | | | |
| Electrical | AS/NZS 60335.2.29 | | |
| EMC | CISPR14 | | |

Table 19 Specification of PM235J

WARRANTY STATEMENT

Applicable only to product sold in Australia

Brown & Watson International Pty Ltd of 1500 Ferntree Gully Road, Knoxfield, Vic., telephone (03) 9730 6000, fax (03) 9730 6050, warrants that all products described in its current catalogue (save and except for all bulbs and lenses whether made of glass or some other substance) will under normal use and service be free of failures in material and workmanship for a period of three (3) years (unless this period has been extended as indicated elsewhere) from the date of the original purchase by the consumer as marked on the invoice. This warranty does not cover ordinary wear and tear, abuse, alteration of products or damage caused by the consumer.

To make a warranty claim the consumer must deliver the product at their cost to the original place of purchase or to any other place which may be nominated by either BWI or the retailer from where the product was bought in order that a warranty assessment may be performed. The consumer must also deliver the original invoice evidencing the date and place of purchase together with an explanation in writing as to the nature of the claim.

In the event that the claim is determined to be for a minor failure of the product then BWI reserves the right to repair or replace it at its discretion. In the event that a major failure is determined the consumer will be entitled to a replacement or a refund as well as compensation for any other reasonably foreseeable loss or damage. This warranty is in addition to any other rights or remedies that the consumer may have under State or Federal legislation.

IMPORTANT NOTE

Our goods come with guarantees that cannot be excluded under the Australian Consumer Law. You are entitled to a replacement or refund for a major failure and compensation for any other reasonably foreseeable loss or damage. You are also entitled to have the goods repaired or replaced if the goods fail to be of acceptable quality and the failure does not amount to a major failure.

Distributed by

AUSTRALIA

Brown & Watson International Pty Ltd

Knoxfield Victoria 3180
Telephone (03) 9730 6000
Facsimile (03) 9730 6050
National Toll Free 1800 294 294

NEW ZEALAND

Narva New Zealand Ltd

22–24 Olive Road
PO Box 12556 Penrose
Auckland New Zealand
Telephone (09) 525 4575
Facsimile (09) 579 1192

IS469

Issue 2020/10