

protech

12VDC Lithium & Lead Acid Battery Tester

SPECIALIST



User Manual

QP2262

1. SAFETY NOTE

1.1 Safety Information

For your own safety and the safety of others, and to prevent damage to the equipment and vehicles, read this manual thoroughly before operating your battery tester. The safety messages presented below and throughout this user's manual are reminders to the operator to exercise extreme care when using this device. Always refer to and follow safety messages and test procedures provided by vehicle manufacturer. Read, understand and follow all safety messages and instructions in this manual.

1.2 Important Safety Instructions

WARNING

- Do not smoke, strike a match, or cause a spark near the vehicle while testing and keep all sparks, heated items and open flames away from the battery and fuel / fuel vapours as they are highly flammable.
- The device should not be used again when abnormal phenomena occur during the test. If smoke, peculiar smell or abnormal noise occurs, stop using it immediately and contact the supplier. Use under abnormal conditions may cause accidents, fires, etc.
- Prevent engine oil, gasoline, antifreeze and electrolyte from contacting this product, which may cause surface deterioration of this product.
- If the skin of the cable is damaged, it may cause a short circuit, so stop using it immediately and send it for repair.
- After the test, please remove the alligator pliers from the battery terminal, otherwise it may cause the product to malfunction or damage the battery.
- Do not use alcohol-based liquids to wipe the product, as it may crack.
- Do not allow engine oil to adhere to the metal parts of the alligator pliers, which may cause poor contact.

2. PRODUCT DESCRIPTION

2.1 Product Introduction

QP2262 battery tester adopts the world's most advanced conductance test technology, which can conveniently, quickly and accurately measure the cold cranking current capacity and battery health of the vehicles battery without damaging the battery performance. It has the ability to quickly detect the vehicle common faults of cranking system and charging system.

2.2 Function Description

- Quickly test the health of 12V batteries, including the lead-acid and lithium types, and show status with the result of "Good Battery" / "Replace" / "Good & Recharge" / "Charge & Retest" / "Bad Cell".
- Test 12V/24V cranking system and charging system of vehicles.
- Batch battery test mode is available through "Fn" button.
- Connect to the computer through the USB port to transfer the test data.
- With reverse polarity protection function, wrong connection will not damage the tester, car or battery.

Support English, German, Spanish, French, Dutch and Italian.

2.3 Product Information

Up / Down keys: Select upwards or downwards via white UP and DOWN keys.

Exit key: Exit to previous menu via EXIT key at the left.

ENTER key: Confirm the selection via ENTER key at the right

FN Key: Set the One-Click-Key function

- **Mini-USB Socket (in the side of the product):**

Connect to computer for print via USB cable.



2.4 Product Specifications

- 1). Display: large, 128*64 easy to read LCD, backlit
- 2). Operating Temperature: -10°C to 60°C (14°F to 140°F)
- 3). Storage Temperature: -20°C to 70°C (-4 °F to 158 °F)
- 4). Power—provided via vehicle battery (8-30V DC)
- 5). Dimensions: Length-126 mm , Width-76 mm, Height - 23mm
- 6). Weight: 228g

2.5 Cold Cranking Amps Measure Range:

Lithium Ion Battery:

Measure Standard	Measure Range
CCA	20-1000
BCI	20-1000
CA	20-1000
MCA	20-1000
JIS	26A17—150F51
DIN	20-700
IEC	20-700
EN	20-1000
SAE	20-1000
GB	2-120Ah

Regular Flooded ,AGM Gel battery, EFB battery:

Measure Standard	Measure Range
CCA	100-2000
BCI	100-2000
CA	100-2000
MCA	100-2000
JIS	26A17—245H52
DIN	100-1400
IEC	100-1400
EN	100-2000
SAE	100-2000
GB	30-220Ah

2.6 Accessories Included

- 1) User Manual -- Instructions on tool operations
- 2) USB cable -- Provides link to tool and computer for print..
- 3). CD--- Print software inside.

3. BATTERY TESTER SETUP

3.1 Tester Setup

The tool allows you to make the following adjustments and settings:

Language – Select the desired language

Fn Setup – Set the one-click-key function

- **Contrast adjustment** – Adjusts the contrast of the LCD display
- **Tool information** – The tool shows the software and hardware version

System setup

From main menu, select the System Setup and press Enter.

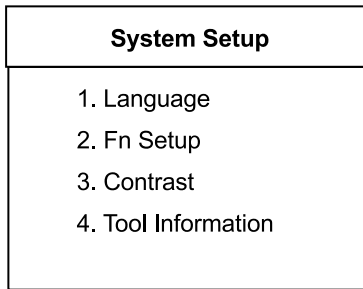

Language:

1) From System Setup menu, use Enter key to select Language.



2) Use UP and DOWN button to select the desired language and press Enter button to save your selection and return to previous menu.

Fn Setup:

1) From System Setup menu, use Enter key to select

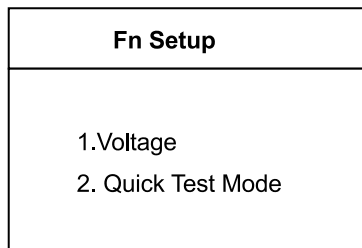

2) Use UP and DOWN button to select the desired one-click quick function. Quick Test Mode is suitable for some parameters batteries test.

That means, after inputting the battery parameters during first test, the user can then press the Fn button to quickly get the test result of continuous same parameters batteries test, as long as the Quick Test Mode is selected.

Contrast

1) From System Setup menu, use Enter key to select contrast.

2) Use UP and DOWN button to select the contrast value and press Enter key to save your selection and return to previous menu.

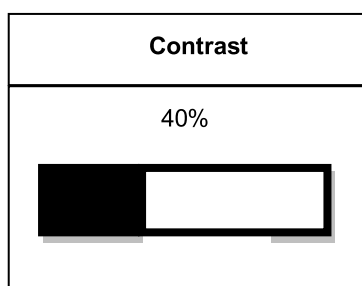

Tool Information

From System Setup menu, use Enter key to select Tool Information

Press exit to return the previous menu.

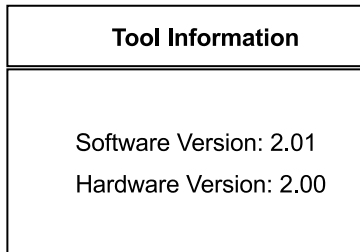

Operation and Test

After connecting the tool to vehicle battery, tester displays the battery real-time voltage.



Tester will display the following contents after press any key.

4. BATTERY TESTER OPERATION

4.1 Battery test

Select Car / Scooter Battery

After the battery test selected, tester will prompt to select Car / Scooter batteries. Press UP/DOWN key to select Car / Scooter, then press ENTER key to confirm.

Select Battery Type

After Car / Scooter selected, tester will prompt to select battery type, i.e. Regular Flooded, Lithium Ion, AGM Flat Plate or AGM Spiral, Gel and EFB battery. Press UP/DOWN key to select battery type, then press ENTER key to confirm.

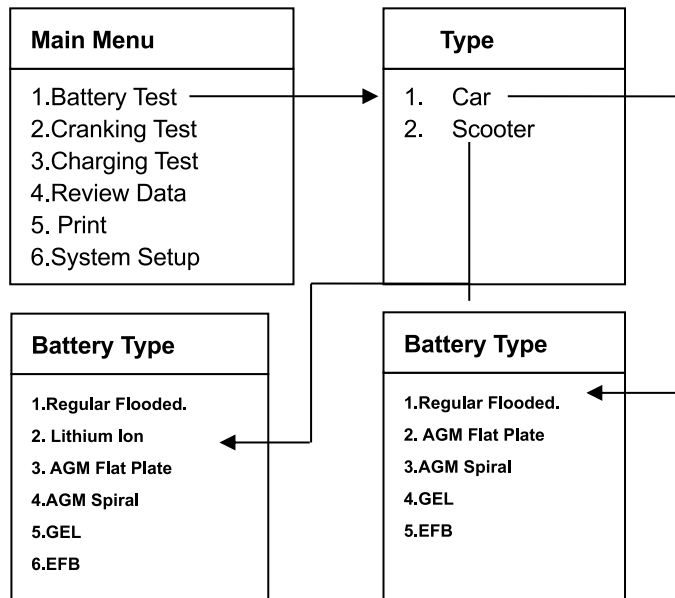

Note: Lithium Ion battery only exists in Scooter battery types, not car.

Battery System Standard and Rating

QP2262 battery tester will test each battery according to the selected system and rating. Use UP/DOWN key to select according to the actual system standard and rating marked on the battery. Use UP/DOWN key to select according to the actual system



standard and rating marked on the battery. See in the below picture, the arrow indicated location.

CCA: Cold Cranking Amps, specified by SAE&BCI, most frequently used value for starting battery at 0°F (-18°C).

BCI: Battery Council International standard

CA: Cranking Amps standard, effective starting current value at 0°C

MCA: Marine Cranking Amps standard, effective starting current value at 0°C.

JIS: Japan Industrial Standard, displayed on the battery as combination of the numbers and letters, e.g. 55D23,80D26.

DIN: German Auto Industry Committee Standard

IEC: Internal Electro technical Commission Standard

EN: European Automobile Industry Association Standard

SAE: Society of Automotive Engineers Standard

GB: China National Standard

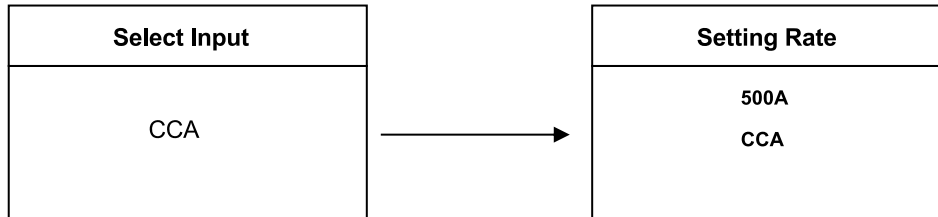

It takes around 5 seconds to display the battery test result.

4.2 Battery Test Result

Battery test result includes 5 types as following:

1) Good Battery

Health: 96%	490A
Charge: 97%	12.64V
Internal R=6.1mΩ	
Rated: 500A	CCA
GOOD BATTERY	

2) Good, Recharge

Health: 78%	440A
Charge: 31%	12.20V
Internal R=7.2mΩ	
Rated: 500A	CCA
GOOD, RECHARGE	

3) Replace

Health: 8%	144A
Charge: 99%	12.68V
Internal R=18.1mΩ	
Rated: 500A	CCA
REPLACE	

4) Bad Cell

Health: 10%	165A
Charge: 0%	9.97V
Internal R=17.83mΩ	
Rated: 500A	CCA
BAD CELL	

5) Charge, Retest

Health: 39%	310A
Charge: 12%	12.08V
Internal R=30.1mΩ	
Rated: 500A	CCA
CHARGE-RETEST	

4.3. Cranking Test

Tester prompts as following:

Cranking Test
1. 12V
2. 24V

Use the Up/Down button to select 12V or 24V cranking system, press the Enter key to select. Tester will go to next screen.

Cranking Test
START ENGINE

Starting the engine as prompted, tester will automatically complete the cranking test and display the result.

Cranking Test	
RPM Detected	

Normally, in a 12V system cranking voltage value lower than 9.6V is regarded as abnormal, and it is OK if it is higher than 9.6V.

Test result of the tester includes actual cranking voltage and actual cranking time.

Cranking Test	
Time	780ms
Voltage	10.13V
CRANKING	NORMAL

This is for the convenience of the maintenance personnel to quickly know the whole state of the starting system according to the data.

After testing finished, do not shut down the engine, select Charging Test to do Charging test.

4.4 Charging Test (Alternator Test)

Tester prompts as following

Select "Charging Test" and press Enter button to start the charging test.

Note: Do not shut down the engine during the test. Do the steps according to the following instructions.

Choose to test 12V/24V charging system.

Charging Test	
1. 12V	
2. 24V	

Ripple Test	
Turn off headlights and air conditioner, keep 10 seconds.	
Press ENTER continue	

Unloaded Test	
Turn off all devices, increase RPM to 2500-3000r/min and keep 10 seconds.	
Press ENTER continue	

Loaded Test	
Turn on headlights and air conditioner to the max wind, keep RPM idle for 10s. Press ENTER continue	

After the test has finished, the tester displays the loaded and unloaded charging voltages, ripple voltage and charging test result.

Charging Test	
UnLoaded	14.39V
Loaded	14.16V
Ripple	15mV
Voltage Normal	

Note: "NO OUTPUT" means Charging system is no output. The vehicle will stop working when the battery is exhausted. Please check the alternator or contact the maintenance service center immediately.

4.5 Review Data

Choose the function of Review Data and review the history of battery testing result

Health: 96%	490A
Charge: 97%	12.64V
Internal R=6.1mΩ	
Rated: 500A	CCA
GOOD BATTERY	





4.6 Print Data

Choose the function of Print and press ENTER.

Before choose the print data function, it is necessary to connect the tool to the computer via USB cable.

Once all are available, please kindly insert the CD to the computer

1. Install the USB driver firstly.

 Manual	2015/5/14 16:35
 Print Software	2015/5/14 16:35
 USB Driver	2015/5/14 16:43
 Read me.txt	2015/5/14 16:44



2. Then open the Print software



Please remember to select the supported COM port, and then select your desired language. The print software supports multi languages.

After all settings are complete, click “Open Port”.

Note: If you don't click the “Open Port” button, the print software will not output test result when you press “Print Data” on the device.

And after clicking the "Open Port" button, the language can no longer be modified.
The language can only be reselected after clicking "Close Port".

Note: If the print software has an updated version, when the user opens it, it will be prompted that there is an upgradeable version.
Just click the "Update" button, you can directly upgrade the print software online.

If there are some history data in print software, please kindly clear them.

3. Choose the function of Print in the tool

Main Menu
1. Battery Test
2. Cranking Test
3. Charging Test
4. Review Data
5. Print

Then it will enter the sub-menu as below

Print Data
1. Print Battery
2. Print Cranking
3. Print Charging
4. Print All

4. Choose the information you want to print.

Once the data is transferred to the computer, the print software will show the latest test result information.
The data can be printed via PC printer.

Distributed by:
Electus Distribution Pty Ltd
46 Eastern Creek Dr,
Eastern Creek NSW 2766 Australia
Ph 1300 738 555
Int'l +61 2 8832 3200
Fax 1300 738 500

www.electusdistribution.com.au