

REDCAT

1/10th Scale Monster Truck

Instruction Manual

MAN-RCMT10E-2021.7.19



1:10
1:10 SCALE
OFF-ROAD

WATERPROOF
ELECTRONICS

BRUSHLESS
MOTOR

2.4 GHz
RADIO SYSTEM

4x4
4 WHEEL DRIVE

To ensure that you are using the most recent version of this manual:
<https://www.redcatracing.com/pages/manuals>





WARNING!

AGE WARNING!

- ▶ This radio controlled (RC) vehicle is not a toy! You must be 14 years of age or older to operate this vehicle. Adult supervision is required.

RISK OF RUNAWAY VEHICLE OR INJURY!

- ▶ Never turn on the vehicle or plug in the battery pack without first having the controller turned on.

RISK OF FIRE! RISK OF EXPLOSION!

- ▶ There is a risk of fire and explosion when dealing with batteries. Rechargeable batteries may become hot and catch fire if left unattended or charged too quickly.
- ▶ Use extra caution when charging LiPO batteries. Use only LiPO specific chargers. Use a LiPO safe charging pouch when charging LiPOs. Charge away from flammable materials.
- ▶ Never charge at a rate higher than 1C. (2000Mah pack= 2amps charge rate). Overcharging can lead to fire and explosion. Always store battery packs in a cool dry place.
- ▶ Never leave the battery plugged into the ESC when the vehicle is not in use.
- ▶ Never connect two batteries to one another.

RISK OF BURNS!

- ▶ The batteries, electronic speed controller (ESC), electric motor, and other areas of the vehicle can get hot. Burns can occur if touched after vehicle operation. Allow adequate time to cool before handling.

RISK OF ELECTRICAL SHOCK!

- ▶ Use caution when charging batteries. Do not touch positive and negative leads together.
- ▶ Do not lay battery on metal. Use only chargers specified for the battery type being charged.
- ▶ Keep batteries and chargers away from water.

RISK OF INJURY!

- ▶ Hobby grade RC vehicles can cause serious injury or death if not operated correctly.
- ▶ Never use vehicle in crowds. Never chase people or animals. Only drive in safe open areas.
- ▶ Keep body parts away from moving parts.

RISK OF DAMAGE!

- ▶ Never operate RC vehicles on public roads. Damage of vehicle and property can occur. Only operate on open private property.
- ▶ Never charge the battery pack while it is still plugged into the RC vehicle. Always unplug the battery pack from the electronic speed controller (ESC) and remove the battery from the RC vehicle before charging. Failure to do so will result in damage to the vehicle's electronics and void the electronics warranty.

RISK OF RUNAWAY VEHICLE OR INJURY AND DAMAGE!

- ▶ Do not mix old and new batteries. Do not mix alkaline, lithium, standard (carbon zinc), or rechargeable (nickel cadmium) batteries. Do not change or charge batteries in a hazardous location. Only use new AA batteries in your radio transmitter. Replace transmitter batteries often to ensure full control of the vehicle.
- ▶ Perform a radio range check BEFORE running your RC vehicle to avoid a runaway vehicle.

FCC COMPLIANCE STATEMENT!

- ▶ The radio included with your vehicle complies with part 15 of the FCC Rules. Operation is subject to the following two conditions:

- (1) This device may not cause harmful interference, and
- (2) This device must accept any interference received, including interference that may cause undesired operations.

Note: This equipment has been tested and found to comply with the limits for a Class B digital device, pursuant to Part 15 of the FCC Rules. These limits are designed to provide reasonable protection against harmful interference in a residential installation. This equipment generates, uses and can radiate radio frequency energy and, if not installed and used in accordance with the instructions, may cause harmful interference to radio communications. However, there is no guarantee that interference will not occur in a particular installation. If this equipment does cause harmful interference to radio or television reception, which can be determined by turning the equipment off and on, the user is encouraged to try to correct the interference by one of the following measures:

Reorient or relocate the receiving antenna. Increase the separation between the equipment and receiver. Connect the equipment into an outlet on a circuit different from that to which the receiver is connected. Consult the dealer or an experienced radio/TV technician for help.

- ▶ **WARNING:** Any changes or modifications not expressly approved by the party responsible for compliance could void the user's authority to operate this equipment.
- ▶ **WARNING:** While operating the Radio, a separation distance of at least 20 centimeters must be maintained between the radiating antenna and the body of the user or nearby persons in order to meet the FCC RF exposure guidelines.



Perform a radio range check:

- ▶ Install new AA batteries into the bottom of the transmitter.
 - ▶ Turn on the transmitter.
 - ▶ Turn on the ESC power switch, which is found in the vehicle.
 - ▶ Check that the controls are working properly.
 - ▶ Keep fingers away from potentially moving parts and hold the vehicle off the ground.
- Note:** Always turn on the transmitter first to prevent runaways.
- ▶ Check that the controls are working properly. The steering wheel should operate the steering and the trigger should operate the motor. Pulling the trigger should make the vehicle go forward, pushing the trigger should apply the brake and reverse. You may need to adjust the throttle trim found on the transmitter to keep the wheels from spinning while the trigger is in the neutral position.
 - ▶ Have a friend hold the vehicle and walk 50 yards away. You and your friend should decide on a routine beforehand, since it will be difficult to communicate with each other while testing. An example would be:
 - ▶ Turn the steering wheel left and count to ten
 - ▶ Turn the steering wheel right and count to ten
 - ▶ Pull the trigger and count to ten
 - ▶ Push the brakes and count to ten.
 - ▶ You will want to repeat these steps moving further out as you progress until you are beyond the maximum distance you plan to run the vehicle.
 - ▶ If the radio performed without any glitches or twitching at maximum distance, you are ready.

Water Warning:

- ▶ After vehicle gets wet, please unplug the ESC from the battery to avoid putting users in danger. Also, rust proofing the bearings and metal parts is highly recommended.



- ▶ If you feel driving in water is necessary, please seal all holes in the tires and rims before performing this action to prevent the tire foam from absorbing water inside the tires.

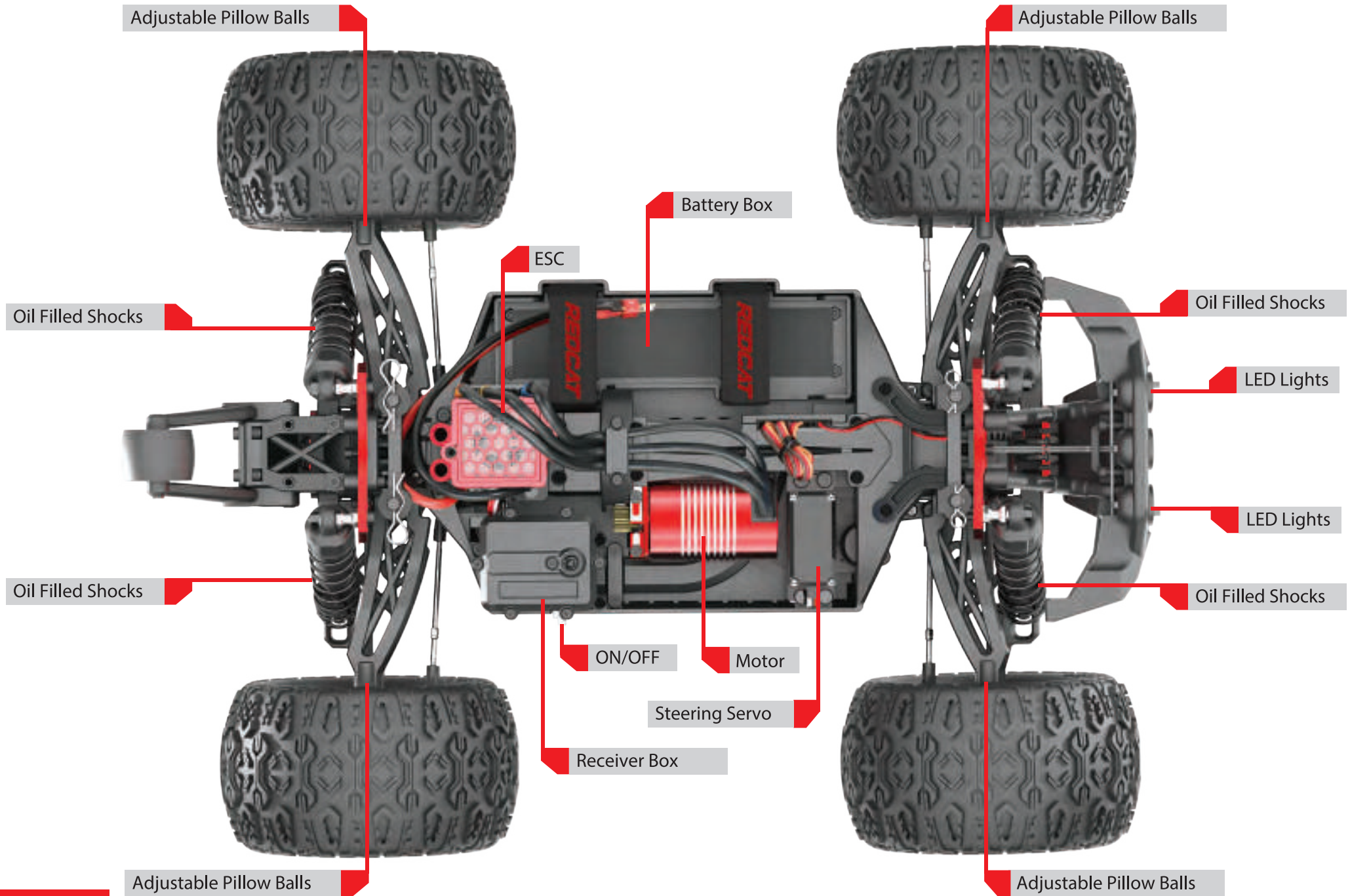



Thank you for choosing the Redcat RC-MT10E monster truck. The RC-MT10E is designed to be fun to drive and uses top quality parts for performance and durability. Before you start using your new RC kit, we suggest you read through the instruction manual first. Be sure to check all tips before you start. We hope you enjoy your new Redcat RC.

Features: Specifications:

- ▶ Factory assembled
- ▶ Bright LED Lights included
- ▶ Reinforced Differentials
- ▶ Hardened Steel Driveshafts
- ▶ Stylish Body
- ▶ Large Wheels and Tires
- ▶ Wheelie Bar
- ▶ High Quality Ball Bearings
- ▶ Super Strong, Long Travel Suspension
- ▶ Adjustable Turnbuckles

- ▶ 1/10 4WD EP Monster Truck
- ▶ Ground Clearance: 55mm
- ▶ Length: 428mm
- ▶ Width: 343mm
- ▶ Wheelbase: 270mm
- ▶ Height: 186mm
- ▶ Powerful 4400KV Brushless Motor
- ▶ Heavy Duty Waterproof 80A 2S-3S ESC
- ▶ Heavy Duty Waterproof Servo
- ▶ 2.4GHz Radio System



Thank you for purchasing the RC-MT10E. To drive the vehicle, you will need to acquire the following items.

1 Included tools

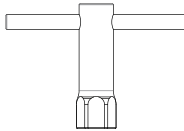
- Cross Wrench (17mm)
- 

2 Required items

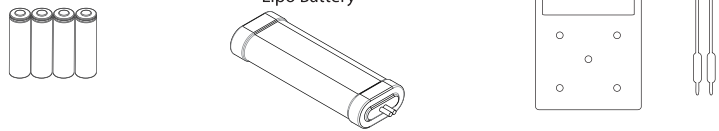
- AA Alkaline Or Rechargeable Batteries For Transmitter, 4pcs
 - 2S (7.4V) or 3S (11.1V) Rechargeable Lipo Battery
 - LIPO Battery Pack Charger
- 

3 Helpful equipment

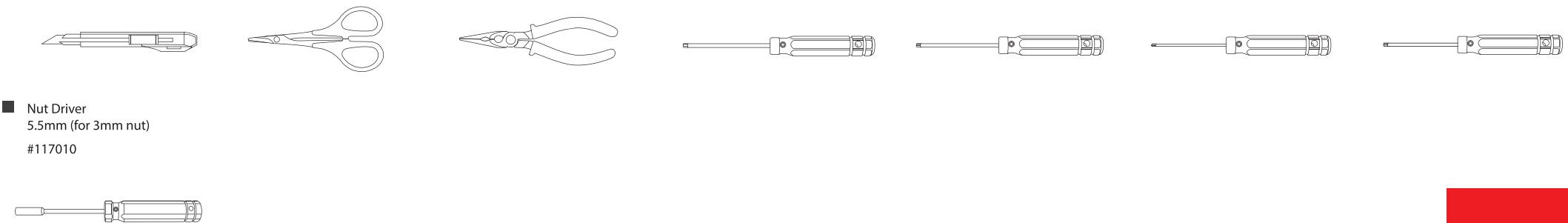
- Hobby Knife (Warning!! This knife cuts nylon parts and fingers with equal ease. Be careful.)
 - Body Scissors (for body cutting) #116006
 - Needlenose Pliers
 - Hex Wrench Metric Size 1.5mm #117057-1
 - Hex Wrench Metric Size 2.0mm #117057-2
 - Hex Wrench Metric Size 2.5mm #117057-3
 - Hex Wrench Metric Size 3.0mm #117057-4
 - Nut Driver 5.5mm (for 3mm nut) #117010
- 

Instruction & Setup Manual

1 Transmitter Function

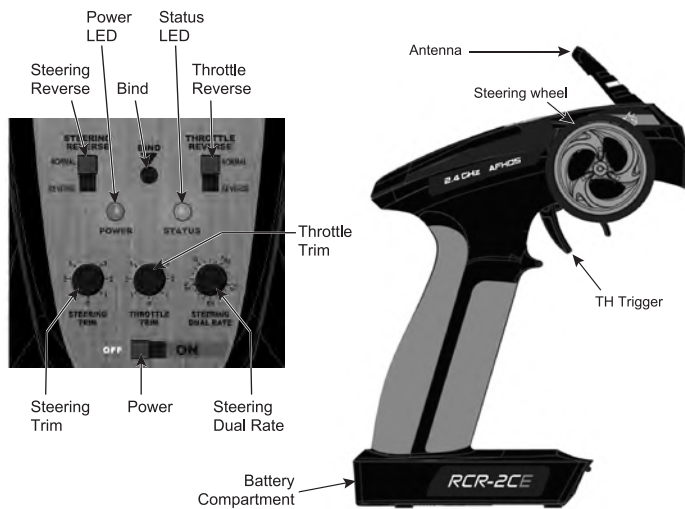

- 03**
- Pull the throttle trigger to move the vehicle forward.
 - Push the throttle trigger forward to brake and reverse the vehicle.



2 Operating Procedure

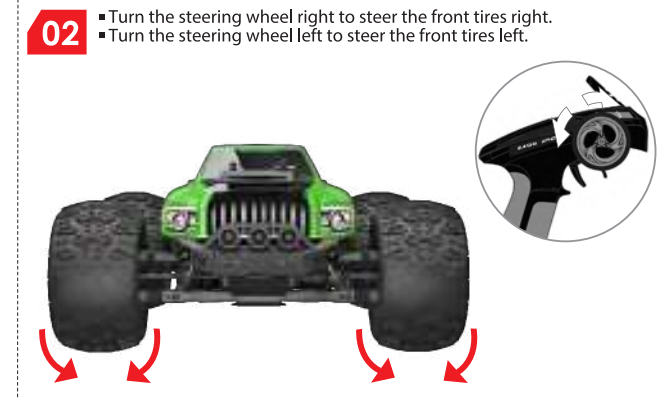
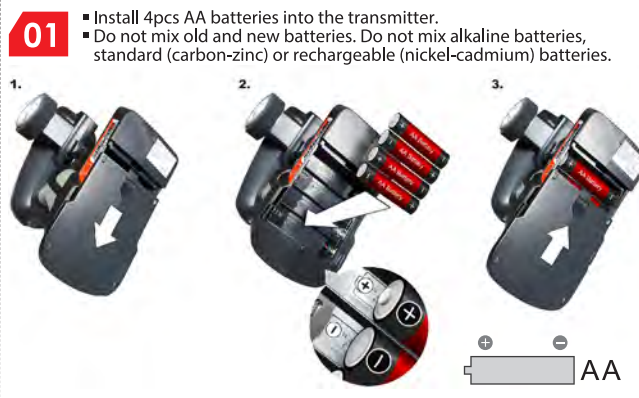

Additional Controls & Binding

Radio:

- Steering Reverse Switch:** Top left switch. Used to change steering orientation. If the car turns right when you steer left, flip this switch.
- Throttle Reverse Switch:** Top right switch. Used to change throttle trigger orientation. If the car goes in reverse while you pull the throttle trigger, flip this switch.
- Power LED:** Left LED light. Lights up when the transmitter is turned on.
- Status LED:** Right LED light. Lights up green when transmitter batteries are full. Flashes when transmitter batteries are low and need replacing.
- Bind Button:** Used to bind the transmitter to the receiver. See binding instructions.
- Steering Trim:** Left knob. Used to set the steering neutral point. If the vehicle veers in one direction while the steering wheel is centered, turn this knob in the opposite direction until the car drives straight.
- Throttle Trim:** Middle knob. Used to set the throttle neutral point. If the vehicle moves forward or reverse while the throttle trigger is centered, turn this knob until the vehicle remains still. For maximum setting, turn slowly until the vehicle creeps forward, then turn the knob the opposite direction until the car stops.
- Steering Dual Rate:** Right knob. Used to limit the amount of steering. 0= little/no steering & 100= maximum steering. Set the knob to the amount of steering you feel comfortable with. If the vehicle has a tendency to spin out, lower the steering rate.
- On/Off Switch:** Bottom switch. Turns transmitter On and Off.

Receiver:

- BIND/VCC:** Used when binding to transmitter.
- Ch3:** Used for 3rd channel when needed.
- Ch2:** Used for electronic speed controller (ESC).
- Ch1:** Used for steering servo.
- Failsafe Button:** Used to set failsafe.

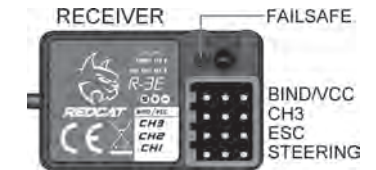

Binding Process:

1. Insert the BIND PLUG into the receiver BIND port.
2. Make sure your ESC is plugged into CH2, and insert the bind plug into BIND/VCC. Now, power the vehicle on and the receiver light should begin to blink red.
3. Press the BIND button in the center of the transmitter's Control Panel and turn on radio.
4. Release the bind button when you see the green light on the radio flashing. At this point, your receiver's LED light should pause for approximately 1 second and then blink slowly. Turn off the power to your vehicle, as well as the radio.
5. Remove the BIND PLUG from the receiver. Make sure the servos and ESC are attached as described above.
6. First turn your radio on, then your vehicle as normal. Your radio and receiver should be bound together and communicating with each other.

ESC Features

- ▶ ESC is compatible with sensorless brushless motors and sensed brushless motors (only in sensorless mode).
- ▶ Fully waterproof design for all weather conditions. After running in water, clean and then dry the ESC to avoid the oxidation of copper connectors)
- ▶ Super internal switch-mode BEC with switchable voltage of 6V/7.4V and a cont. /peak current of 3A/6A for use with high torque servos and high voltage servos.
- ▶ Highly reliable electronic switch avoids troubles which may happen to traditional mechanical switches.
- ▶ Proportional brake with 9 levels of maximum brake force and drag brake force.
- ▶ 5 levels of acceleration/punch from soft to aggressive for different terrain, tires and tracks.
- ▶ Multiple protections: motor lock-up protection, low-voltage cutoff protection, thermal protection, overload protection, fail safe (throttle signal loss protection), and capacitor damage protection.
- ▶ Single button ESC programming and factory reset, or advanced programming via portable LED program card (sold separately) or multifunction LCD program box (sold separately).

ESC Specifications

Model	EZRUN-MAX10
Continuous/Burst Current	80A / 520A
Motor Supported	Sensored / Sensorless Brushless Motor (only in sensorless mode)
Programming Port	Fan / Programming Port
Motor Limit	2S LIPO/6 Cell NiMH: KV<5000 / 3S LIPO/9 Cell NiMH: KV<3000 (3656 size motor)
Fan (included)	Powered by a stable BEC voltage of 6V / 7.4V
Battery	2-3S LIPO / 6-9 Cell NiMH
BEC Output <i>Note1</i>	6V / 7.4V Switchable, 3A Continuous Current (Switch Mode)
Dimensions	49mm(L)*39.5mm(W)*34.7mm(H)
Weight	105g

NOTE 1: The cooling fans Powered by the stable BEC voltage of 6V/7.4V and is always working.

ESC Connections

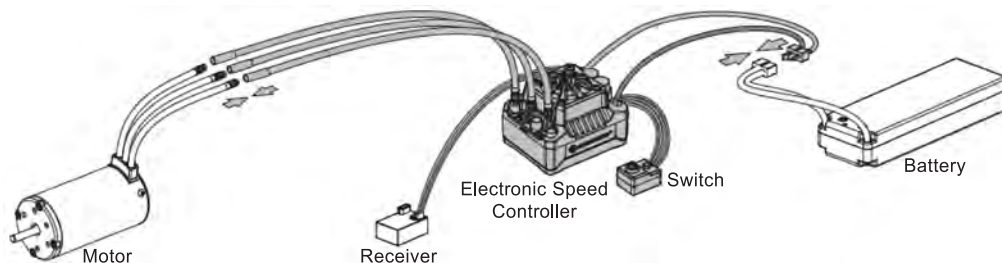

- ▶ **Motor Wiring**
There is no polarity on the A/B/C ESC/MOTOR wires. If the motor runs in reverse, just swap two of the wires.
- ▶ **Receiver Wiring**
Plug the receiver cable (small black plug with three small wires coming out of it) into the throttle (2CH) on the receiver. Do not connect an additional receiver battery into the receiver, this may damage the ESC.
- ▶ **Battery Wiring**
Plug the approved (see above) battery pack into the ESC battery plug. Be sure the polarity is correct! The red (+) of ESC to the red (+) of the battery, and the black (-) of the ESC to the black (-) wire of the battery. If polarity is reversed, the ESC will be damaged. This will not be covered under warranty!

ESC Calibration

To ensure transmitter throttle input corresponds with the ESC output, you should calibrate the ESC. Do this whenever you change transmitters, and before you set the TRIM, D/R, EPA and other throttle channel parameters on your transmitter. Follow these steps below.

1. Turn on the transmitter. Set the throttle EPA to 100% and center the throttle trim (0).

2. With the transmitter still on and the ESC off, connect the battery pack to the ESC battery leads.

3. Press and hold the SET button while you press the ON/OFF button briefly.

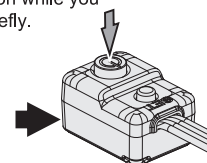
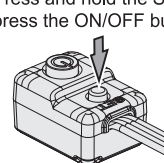

Release the SET button once the LED flashes.

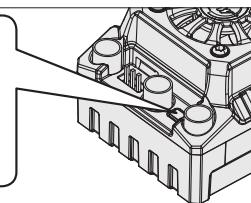

Note: The ESC will enter the programming mode if the SET button is not released in 3 seconds and then you need to restart from step 1.

4. Set the trigger to the neutral position and press the SET button.

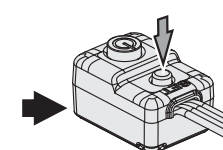
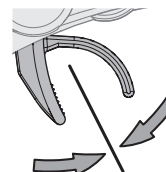

The Green LED flashes once and motor emits "Beep" tone.

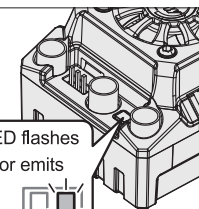

5. Pull the trigger to the full throttle position and press the SET button.

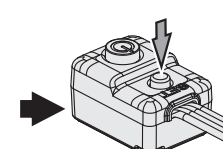
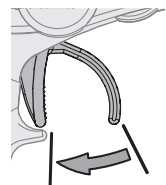

The Green LED flashes twice and motor emits "Beep-Beep" tone.

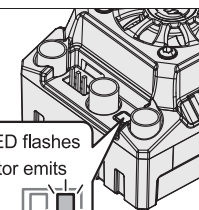

6. Push the throttle trigger to full brake position and press the SET button.

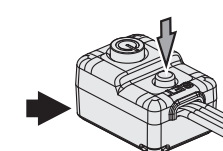
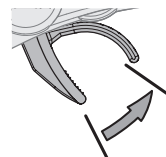

The Green LED flashes three times and motor emits "Beep-Beep-Beep" tone.

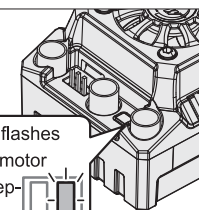



ESC Programming

(Shaded boxes indicate factory default settings)

Programmable Items	Parameter Values								
	# 1	# 2	# 3	# 4	# 5	# 6	# 7	# 8	# 9
1. Running Mode	Fwd/Br	Fwd/Rev/Br							
2. LiPo Cells	Auto Calculation	2S	3S						
3. Low Voltage Cutoff	Disabled	Auto (Low)	Auto (Intermediate)	Auto (High)					
4. ESC Thermal Protection	105°C/221°F	125°C/257°F							
5. Motor Thermal Protection	Disabled								
6. Motor Rotation	CCW	CW							
7. BEC Voltage	6.0V	7.4V							
8. Brake Force	12.5%	25%	37.5%	50.0%	62.5%	75.0%	87.5%	100.0%	Disabled
9. Reverse Force	25%	50%							
10. Start Mode (Punch)	Level 1	Level 2	Level 3	Level 4	Level 5				
Advanced Setting									
11. Drag Brake	0%	2%	4%	6%	8%	10%	12%	14%	16%

► 1. Running Mode

► Option 1: Forward with Brake

The vehicle can go forward and brake but cannot reverse in this mode. This mode is used for racing.

► Option 2: Forward / Reverse with Brake

The vehicle can go forward, brake, and reverse. This mode uses the "DOUBLE-CLICK" braking/reverse method. The vehicle only brakes (won't reverse) the 1st time the throttle trigger is pushed forward. When the motor stops and you quickly release and re-push the trigger forward a second time, the vehicle will go into reverse. If the motor does not stop, the vehicle will remain in braking mode. Reverse is only activated if the motor has completely stopped.

► 2. LiPo Cells

"Auto Calculation" is the default setting. If you regularly use the same size LIPO pack, we recommend setting this option manually to avoid incorrect auto calculations. The ESC may mistake a partially charged 3S LIPO for a fully charged 2S LIPO allowing the 3S LIPO to drop below its safe voltage range, causing damage to the battery. To avoid this, only turn on the ESC with a fully charged battery pack installed, or set this option manually according to the LIPO battery cell count being used.

► 3. Low-Voltage Cutoff

Sets the voltage range the ESC lowers or removes power to the motor in order to keep the battery at a safe minimum voltage (for LIPO batteries). The ESC will monitor the battery voltage (according to the cell count set above) and will reduce power to 50% allowing you to drive the vehicle back to yourself. If you are still driving 10 seconds beyond the power drop, all power to the motor will be cut. This is to keep the LIPO batteries from dropping below their safe voltage threshold. The RED LED will flash a short, single flash that repeats (•••) to indicate the low-voltage cutoff protection is activated.

► Option 1: Disabled

The ESC will not monitor voltage. This setting is for NiMH battery packs only. Do not use this setting while using LIPO batteries or they may be irreversibly damaged.

► Option 2: Auto (Low)

For batteries with a poor discharge capability. Not recommended.

► Option 3: Auto (Intermediate)

For batteries with a normal discharge capability. Recommended.

► Option 4: Auto (High)

For batteries with a very high discharge capability.

Warning: ALWAYS use Low-Voltage Cutoff when using LIPO batteries!

ESC Programming (cont.)

► 4. ESC Thermal (Shutdown) Protection/Overheat Protection

The ESC will automatically cut off the output and the GREEN LED will flash a short, single flash that repeats (•••) when the temperature gets up to the value you preset and activates the ESC thermal protection. The output won't resume until the temperature gets down. Setting #1 is recommended.

► 5. Motor Thermal (Shutdown) Protection/Overheat Protection

This item has been permanently set to "Disabled" by manufacturer.

► 6. Motor Rotation

Changes the rotation of the motor while it's shaft is facing you. Counter clockwise or clockwise.

► 7. BEC Voltage :

Changes the voltage supplied to the servos. Use 6.0V for regular servos and 7.4V for high voltage servos.

► 8. Brake Force

Sets the overall braking power when the brake trigger is pushed all the way forward (full brake). A high setting will shorten the braking time but it may damage your pinion and spur.

► 9. Reverse Force

The amount of power the vehicle will have while full reverse is engaged. Start with a low setting.

► 10. Start Mode (Punch)

The amount of initial power while initially pulling the throttle trigger. You can choose a punch level from 1 (very soft) to 5 (very aggressive). This feature is very useful for preventing tire spin during takeoff. This function may be limited to battery capabilities. If the vehicle stutters during takeoff, you will need to lower the punch setting or use a battery with higher discharge capabilities.

► 11. Drag Brake

Drag brake is the amount of brake automatically applied while the throttle is in the neutral position. This is to simulate the natural drag of a brushed motor while coasting.

► Programming Flow Chart

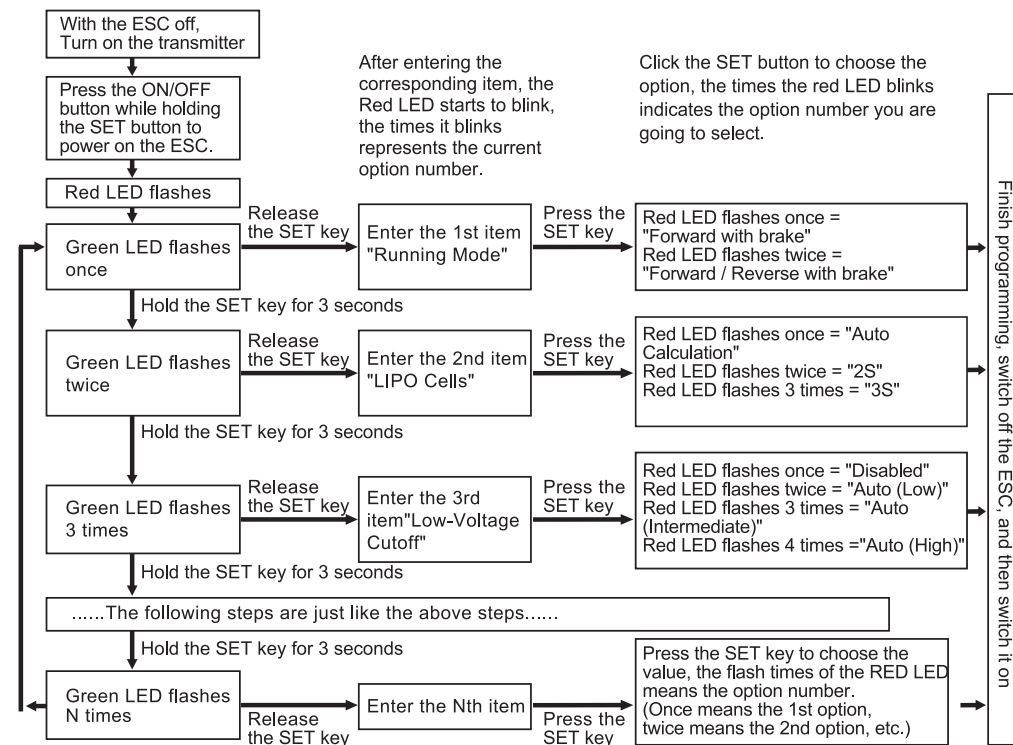

ESC Troubleshooting

Trouble	Possible Reason	Solution
After power on, motor and cooling fan don't work.	No power supplied to the ESC.	Check if all ESC & battery connectors have been well soldered or firmly connected.
	The ESC switch is damaged.	Replace the broken switch.
After power on, motor doesn't work, but emits "beepbeep-, beep- beep-" alert tone. (Every "beep- beep-" has a time interval of 1 second)	Input voltage is abnormal, too high or too low.	Check the voltage of the battery pack.
	The ESC didn't detect any throttle signal.	Be sure throttle wire is properly plugged into the receiver and in the correct channel. Ensure the transmitter is turned on.
After the ESC was powered on and finished LiPo cell detection (the GREEN LED flashed N times), and then the RED LED flashed rapidly.	The neutral throttle value stored on your ESC is different from the value stored on the transmitter.	Re-calibrate the throttle range after you release the throttle trigger to the neutral position.
	The (ESC-to-motor) wiring order was incorrect.	Swap any two wire connections between the ESC and the motor.
The motor runs in the opposite direction when it is accelerated	Transmitter throttle channel is reversed.	Check the transmitter and the receiver.
	The throttle signal is lost.	Check the signal wire from the throttle channel of your receiver.
The motor suddenly stops running while in working state	The ESC has entered into Low Voltage Protection Mode or Over-heat Protection Mode	Red LED flashing means Low Voltage. Green LED flashing means Over-heat.
	A soldering joint between the motor and the ESC may be bad.	Check all soldering joints, re-solder if necessary.
The motor stutters but won't run properly.	The ESC was damaged (some MOSFETs were burnt).	Contact the distributor for repair or other customer service.
	The throttle neutral position on your transmitter was actually in the braking zone.	Re-calibrate the throttle neutral position. No LED on the ESC will come on when the throttle trigger is at the neutral position.
The vehicle could run forward (and brake), but could not reverse.	The "Running Mode" is improperly set.	Set the "running mode" to "Forward/Reverse with Brake".
	The ESC was damaged.	Contact the distributor for repair or other customer services.
The car ran forward/backward slowly when the throttle trigger was at the neutral position.	The neutral position on the transmitter was not stable, so signals were not stable either.	Replace your transmitter
	The ESC is not calibrated properly.	Re-calibrate the throttle range or fine tune the neutral position on the transmitter.
When pressing the SET button to set the throttle neutral position, the GREEN LED didn't flash and no beep was emitted, or you were unable to set the full throttle endpoint and the full brake endpoint after the neutral position was accepted.	The ESC throttle cable wasn't plugged in the correct channel on the receiver.	Plug the throttle cable into the throttle (TH) or (CH2) channel on your receiver.
	The ESC throttle cable is plugged in backwards.	Plug in the throttle cable properly by referring to relevant mark shown on your receiver.

ESC Factory Reset

- ▶ Restore the default values with the SET button
- ▶ 1) Press and hold the SET button on the ESC for over 3 seconds anytime the throttle trigger is in the neutral position (except during ESC calibration and programming).
- ▶ RED & GREEN LEDs flash simultaneously indicating you have successfully restored all the default values within the ESC.
- ▶ Once the ESC is powered off, then back on again, your settings will be back to the default mode.



WARNING!

- ▶ Ensure all wires and connections are well insulated before connecting the ESC to related devices, short circuit will damage your ESC.
- ▶ Ensure all devices are well connected to prevent poor connection that may cause your vehicle to lose control or other unpredictable issues such as damage to the device.
- ▶ Read through the manuals of all power devices and chassis and ensure the power configuration is rational before using this unit.
- ▶ Do not hold the vehicle in the air and rev it up to full throttle, as rubber tires can "expand" to extreme size, or even crack to cause serious injury.
- ▶ Stop using the ESC when its casing temperature exceeds 90°C/194°F. Over heating your ESC will fatally damage it and possibly the motor.
- ▶ We recommend setting the "ESC Thermal Protection" to 105°C/221 °F {this refers to the internal temperature of the ESC}.
- ▶ We recommend removing the cooling fan from ESC before exposing vehicle to liquids, and fully dry it right after use.
- ▶ Always disconnect the batteries after use, as the ESC will continue to consume current if it's connected to batteries (even if the ESC is turned off).
- ▶ Long-term battery contact will cause batteries to completely discharge and result in damage to batteries or ESC. This WILL NOT be covered under warranty.

Instruction Manual

REDCAT

1/10th Scale Monster Truck



To ensure that you are using the most recent version of this manual:
<https://www.redcatracing.com/pages/manuals>