

# Renogy

Dual Input DC-DC On-Board Battery Charger with MPPT

12V | 30A/50A

VERSION B1

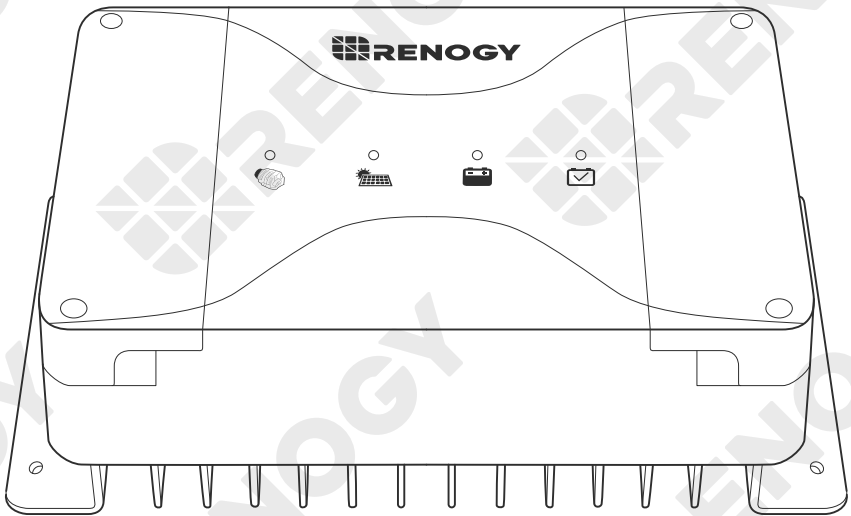

USER MANUAL

## Applicability

The user manual applies to the following products:

- Renogy 12V 30A Dual Input DC-DC On-Board Battery Charger with MPPT (RBC30D1S)
- Renogy 12V 50A Dual Input DC-DC On-Board Battery Charger with MPPT (RBC50D1S)

## Disclaimer

- Renogy makes no warranty as to the accuracy, sufficiency, or suitability of information in the user manual because continuous product improvements are going to be made.
- Renogy assumes no responsibility or liability for losses or damages, whether direct, indirect, consequential, or incidental, which might arise out of the use of information in the user manual.
- Renogy is not responsible or liable for the failures, damages, or injuries resulting from repair attempted by unqualified personnel or improper installation and operation.
- The illustrations in the user manual are for demonstration purposes only. Details may appear slightly different depending on product revision and market region.
- Renogy reserves the right to change the information in the user manual without notice.

## Copyright

Renogy 12V 30A/50A Dual Input DC-DC On-Board Battery Charger with MPPT User Manual © 2022 Renogy. All rights reserved.

All information in the user manual is subject to copyright and other intellectual property rights of Renogy and its licensors. The user manual may not be modified, reproduced, or copied, in whole or in part, without the prior written permissions of Renogy and its licensors.

## Trademarks

The following are trademarks or registered trademarks of Renogy in the United States and other countries and regions:

RENOGY	<b>RENOGY</b>
--------	---------------

All other trademarks in the user manual are the property of their respective owners and their use herein does not imply sponsorship or endorsement of their products or services. The unauthorized use of any trademark displayed in the user manual or on the product is strictly prohibited.

## Date and Revision

March 2022, Revision B1

# Table of Contents

Important Safety Information .....	01
Symbols Used .....	01
General Safety Information .....	01
Overview .....	03
Introduction .....	03
Key Features .....	03
Charging and Activation Logics .....	04
MPPT Technology .....	04
Four Charging Stages .....	05
Lithium Battery Activation .....	06
Package Contents .....	07
Optional Accessories .....	09
Product Overview .....	10
Wiring Diagram .....	11
Recommended Cable and Fuse Sizing .....	12
Recommended Cable Sizing .....	12
Recommended Fuse Sizing .....	13
Components & Tools .....	14
Preparation .....	15
Checking Battery Charger .....	15
Checking Auxiliary Battery .....	16
Checking Solar Panel (Optional) .....	17
Checking Automobile Alternator (Optional) .....	19
Battery Charger Wiring .....	20
Mounting .....	22
Temperature Sensor .....	23
Voltage Sensor .....	24

Communication.....	25
Operation.....	26
Selecting the Battery Type .....	26
Battery Charging Parameters.....	29
User Mode.....	30
Working Logic.....	33
To Solar Panel.....	33
To Starter Battery .....	34
To Both Solar Panel and Starter Battery .....	35
LED Indicators.....	41
Alternator / Charging Indicator.....	41
Battery Type Indicator .....	42
Troubleshooting.....	43
Alternator / Charging Indicator.....	43
Solar Charging Indicator .....	43
Auxiliary Battery Indicator .....	43
Technical Specifications .....	44
Dimensions.....	45
Maintenance.....	46
Inspection.....	46
Cleaning.....	46
Storage.....	46
Emergency Responses .....	47
Fire.....	47
Flooding .....	47
Smell .....	47
Noise.....	47
Technical Support.....	48

# Important Safety Information

## Symbols Used

## General Safety Information

The user manual provides important installation, operation, and maintenance instructions for Renogy 12V 30A/50A Dual Input DC-DC On-Board Battery Charger with MPPT (hereinafter referred to as battery charger). Read the user manual carefully before installation and operation and save it for future reference. Failure to observe the instructions or precautions in the user manual can result in electrical shock, serious injury, or death, or can damage the battery charger, potentially rendering it inoperable. The installation and service of the battery charger might require knowledge of electricity and is recommended to be carried out by qualified personnel.

## Symbols Used

The following symbols are used throughout the user manual to highlight important information:



### WARNING

Indicates a potentially dangerous condition which could result in injury or death.



### CAUTION

Indicates a critical procedure for safe and proper installation and operation.



### NOTE

Indicates an important step or tip for optimal performance.



### INFO

Indicates that more information is available in other documents relating to the subject.

## General Safety Information



### WARNING

- Do not puncture, drop, crush, penetrate, shake, strike, or step on the battery charger.
- Do not open, disassemble, repair, tamper with, or modify the components of the battery charger.
- Install the battery charger on a vertical surface indoors protected from direct sunlight, high temperature, and water. Make sure there is good ventilation.
- Do not insert foreign objects into battery charger.
- Risk of explosion! Never install the battery charger in a sealed enclosure with flooded batteries! Do not install in a confined area where battery gases can accumulate.
- Confirm the polarities of the devices before connection. A reverse polarity contact will result in abnormalities.
- Refer to the [Recommended Cable and Fuse Sizing](#) in this user manual, and select the appropriate cables and fuses according to the usage.
- Keep the battery charger out of the reach of children.
- Wear proper protective equipment and use insulated tools during installation and operation.
- Do not touch the connector contacts while the battery charger is in operation.
- Disconnect all connectors from the battery charger before maintenance or cleaning.
- Do not dispose of the battery charger as household waste. Comply with local, state, and federal laws and regulations and use recycling channels as required.

# Important Safety Information

Symbols Used

General Safety Information

- In the event of fire, use fire extinguishers suitable for electrical equipment.
- If the battery charger is installed improperly on a boat, it may cause damage to the corrosive agents of the boat. Please have the battery charger by a qualified electrician.



## CAUTION

- Do not expose battery charger to flammable or harsh chemicals or vapors.
- Ensure that there is no water source including downspouts, sprinkles, or faucets above or near the battery charger.
- Ensure that the battery pack is properly connected before installation.

# Overview

Introduction

Key Features

## Introduction

Renogy 12V 30A/50A Dual Input DC-DC On-Board Battery Charger with MPPT provides you with many options. With multiple stage and input, the battery charger can charge the auxiliary battery with a starter battery connected to an alternator or with solar panels connected directly to the battery charger.

While the alternator of your car prioritizes the starter battery, the battery charger allows your solar system to charge the auxiliary battery first. It is a smart way to keep the battery fully charged and off-grid for longer. The battery charger can charge the flooded, gel, AGM, or lithium battery. With the BT-2 Bluetooth Module and the DC Home app, you can monitor the device remotely through your phone in real time.

## Key Features

- **Robust and Sleek Design**

The housing of the battery charger is made of steel plates to ensure its firmness and a more fashionable appearance.

- **Multi-input for Battery Charging**

The battery charger offers you many options to charge the auxiliary battery. With multiple input, it can charge the auxiliary battery with a starter battery connected to an alternator or with solar panels connected directly to the battery charger.

- **Multi-stage Battery Charging**

Up to three stage battery charging including bulk, boost, and float as well as equalization for select battery types

- **Multiple Protections**

The battery charger is equipped with undervoltage protection, overvoltage protection, overload protection, overtemperature protection, reverse current protection, reverse polarity protection, and short circuit protection.

- **RJ45 Communication Port Featured**

With the BT-2 Bluetooth Module and the DC Home app, you can monitor the update parameters of the battery charger remotely through your phone.

# Charging and Activation Logics

## MPPT Technology

Based on MPPT (Maximum Power Point Tracking) technology, the battery charger can extract maximum power from the solar panel. With an automatic tracking algorithm, the MPPT technology can track the voltage of the maximum power point that changes with weather conditions, ensuring the harvest of the maximum power throughout the day.

### ■ Current Boost

Generally, the battery charger will “boost” the current in the solar system. The power generated in the solar panel is the same as the power delivered to the battery pack. Power is the product of voltage (V) x amperage (A).

Therefore, assuming 100% efficiency:

$$\begin{aligned} \text{Power In} &= \text{Power Out} \\ \text{Volts In} * \text{Amps In} &= \text{Volts out} * \text{Amps out} \end{aligned}$$

The efficiency of the battery charger is about 92% to 95%. As the maximum power point voltage of the solar system is greater than the battery pack voltage, the potential difference is proportional to the current boost. The voltage of the solar panel needs to be stepped down to a rate at which the battery can be charged in a stable manner. Compared with traditional battery chargers, the battery charger does not waste the stepped down voltage. It is entirely possible to have the solar module input 8 amps of current into the battery charger, and have the battery charger output 10 amps of current to the battery pack. The following shows a graphic point about the output of MPPT technology.

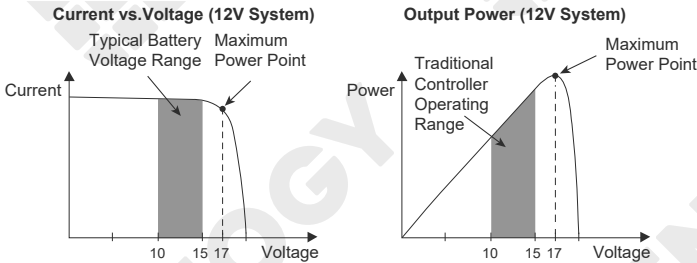

### ■ Limiting Effectiveness

High temperature is the natural enemy of solar panels. With the increase of ambient temperature, the operating voltage (Vmp) of the solar panel decreases, which limits the power generation of the solar panel. The battery charger encounters an inevitably decrease in charging performance even with the MPPT technology. In this case, it is better to use solar panels with higher nominal voltage, so that the battery can still get current boost even if the voltage drops proportionally.

# Charging and Activation Logics

## Four Charging Stages

Renogy 12V 30A/50A Dual Input DC-DC On-Board Battery Charger with MPPT has a four-stage battery charging algorithm for a rapid, efficient, and safe battery charging. They include: Bulk Charge, Boost Charge, Float Charge, and Equalization.

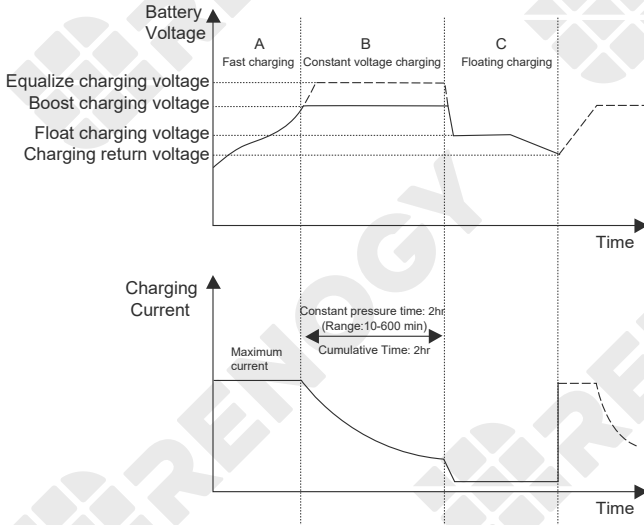

### ■ Bulk Charge:

This algorithm is used for day to day charging. It uses 100% of available solar power to recharge the battery and is equivalent to constant current. In this stage the battery voltage has not yet reached constant voltage (Equalize or Boost), the battery charger operates in constant current mode, delivering its maximum current to the batteries (MPPT Charging).

### ■ Constant Charging:

When the battery reaches the constant voltage set point, the battery charger will start to operate in constant charging mode, where it is no longer MPPT charging. The current will drop gradually. This has two stages, equalize and boost and they are not carried out constantly in a full charge process to avoid too much gas precipitation or overheating of the battery.

**Boost Charge:** Boost stage maintains a charge for 2 hours by default. The user can adjust the constant time and preset value of boost per their demand.

### ■ Float Charge:

After the constant voltage stage, the battery charger will reduce the battery voltage to a float voltage set point. Once the battery is fully charged, there will be no more chemical reactions and all the charge current would turn into heat or gas. Because of this, the battery charger will reduce the voltage charge to smaller quantity, while lightly charging the battery. The purpose for this is to offset the power consumption while maintaining a full battery storage capacity. In the event that a load drawn from the battery exceeds the charge current, the battery charger will no longer be able to maintain the battery to a Float set point and the battery charger will end the float charge stage and refer back to bulk charging.

# Charging and Activation Logics

## ■ Equalization:

Equalization is carried out every 30 days of the month. It is intentional overcharging of the battery for a controlled period of time. Certain types of batteries benefit from periodic equalizing charge, which can stir the electrolyte, balance battery voltage and complete chemical reaction. Equalization charging increases the battery voltage, higher than the standard complement voltage, which gasifies the battery electrolyte.



## CAUTION

- It is recommended to use only non-sealed / vented / flooded / wet cell lead acid batteries in the Equalization stage.
- Do not equalize VRLA type AGM / gel / lithium cell batteries unless permitted by battery manufacturer.







## WARNING

- Once Equalization is active in the battery charging, the battery charger will not exit this stage unless there is a sufficient source of charging current from the solar panel. There should be NO load on the batteries when in equalization charging.
- Overcharging and excessive gas precipitation may damage the battery plates and activate material shedding on them. Too high of an Equalization charging or too long of one may cause damage. Review the specific requirements of the battery used in the system carefully.
- Equalization may increase the battery voltage to a level that damages to sensitive DC loads. Ensure that allowable input voltages of all loads are greater than the set voltage during Equalization charging.

## Lithium Battery Activation

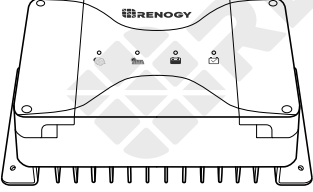
Renogy 12V 30A/50A Dual Input DC-DC On-Board Battery Charger with MPPT has the activation function of lithium battery. Lithium batteries may enter sleep mode when the in-built protection is triggered. In such case, the battery charger provides a small current to reactivate the sleeping lithium battery. The lithium battery can be charged normally after successful activation.

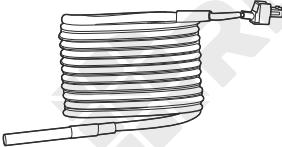
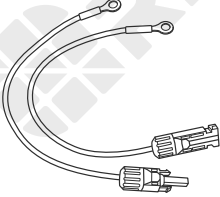
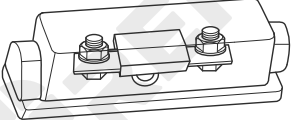
# Package Contents

<p>Renogy 12V 30A/50A Dual Input DC-DC On-Board Battery Charger with MPPT x 1</p>	<p>User Manual x 1</p>
	
<p>Renogy Temperature Sensor x 1</p>	<p>Solar Adapter Cable (Terminal ring to MC4 Adapter Cable)</p>
	
<p>40A or 60A ANL FUSE (Output terminal)</p>	<p>IGN Signal Wire x 1</p>
	

# Package Contents

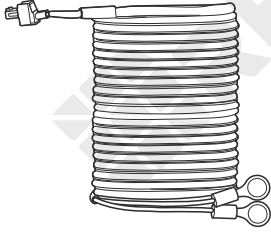
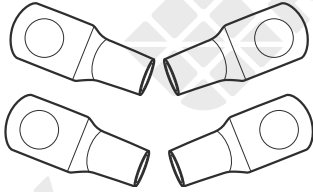
Voltage Sensor × 1	Ring Terminals (M8) × 4
	

**i** NOTE

- You can customize adapter cables by using the included four M8 ring terminals.

# Optional Accessories

## NOTE

- You can buy optional accessories from [renogy.com](http://renogy.com).

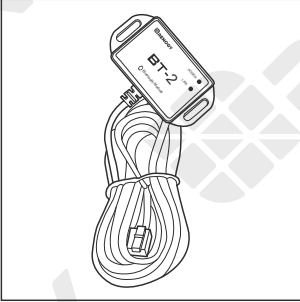

### Renogy BT-2 Bluetooth Module

With a Renogy BT-2 Bluetooth Module (sold separately), the battery charger can be connected to the DC Home app for remote device monitoring.

The battery charger supports bluetooth for system monitoring and parameter modifying with the Renogy BT-2 Bluetooth Module.

Scan the QR code on the last page of the user manual to download the DC Home app.

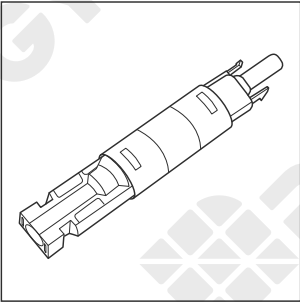

### Solar Panel Fuse

Solar panel fuse provides single circuit protection for solar panels, preventing damage from high currents.

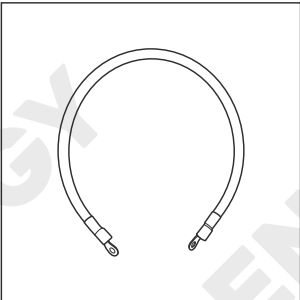

### Fuse Cable

The cable is integrated with copper rings at both ends, enabling the battery charger to be connected with an external fuse.

# Product Overview

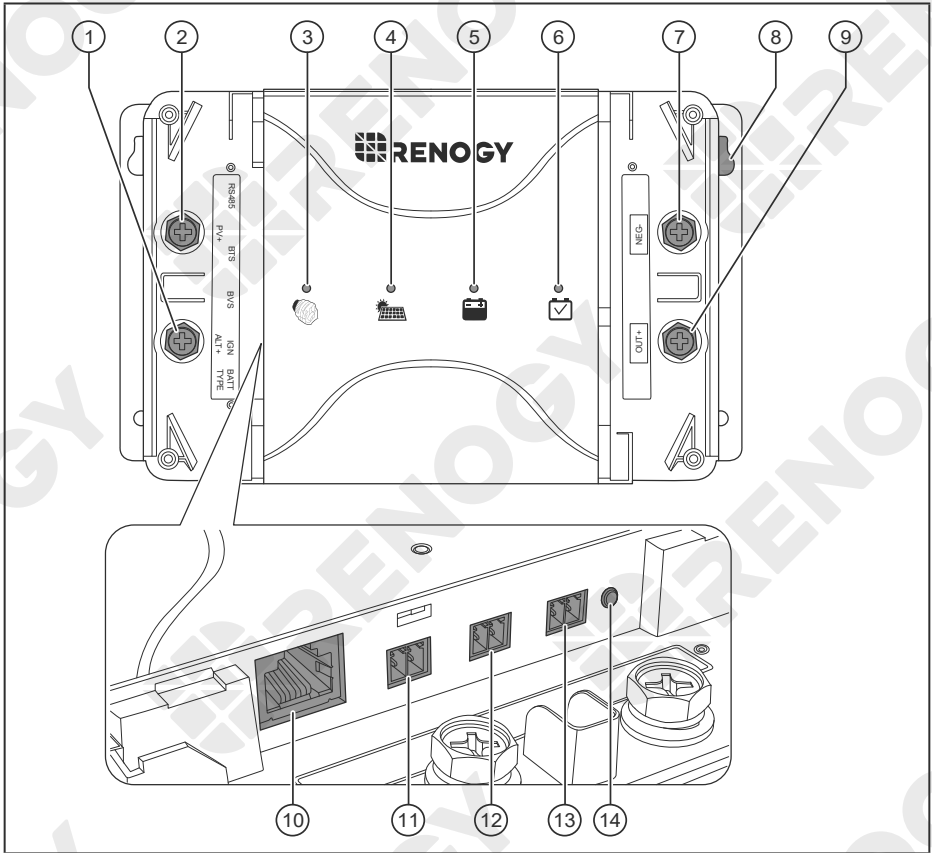

No.	Part	No.	Part
1	Positive Starter Battery Terminal	8	Mounting Hole
2	Positive Solar Terminal	9	Positive House Battery Terminal
3	Alternator / Charging Indicator	10	RS485 Communication Ports
4	Solar Charging Indicator	11	Battery Temperature Sensor Port
5	Auxiliary Battery Indicator	12	Battery Voltage Sensor Port
6	Battery Type Indicator	13	Ignition Signal
7	Negative Common Terminal	14	Battery Type Setting Knob



# Recommended Cable and Fuse Sizing

## Recommended Cable Sizing

## Recommended Fuse Sizing

### Recommended Cable Sizing

Model	Cable	Cable Length (ft) / (m)	Recommended Cable Size
Renogy 12V 30A Dual Input DC-DC On-Board Battery Charger with MPPT (RBC30D1S)	Input	0 ft to 10 ft (0 m to 3 m)	8 AWG to 10 AWG
		11 ft to 20 ft (3 m to 6 m)	4 AWG to 6 AWG
		21 ft to 30 ft (6 m to 9 m)	4 AWG
	Output	0 ft to 10 ft (0 m to 3 m)	8 AWG to 10 AWG
		11 ft to 20 ft (3 m to 6 m)	4 AWG to 6 AWG
		21 ft to 30 ft (6 m to 9 m)	4 AWG
Renogy 12V 50A Dual Input DC-DC On-Board Battery Charger with MPPT (RBC50D1S)	Input	0 ft to 10 ft (0 m to 3 m)	8 AWG
		11 ft to 20 ft (3 m to 6 m)	6 AWG
		21 ft to 30 ft (6 m to 9 m)	4 AWG
	Output	0 ft to 10 ft (0 m to 3 m)	8 AWG
		11 ft to 20 ft (3 m to 6 m)	6 AWG
		21 ft to 30 ft (6 m to 9 m)	4 AWG

#### NOTE

- The cable specifications listed above account for critical, less than 3% voltage drop and may not account for all configurations.
- The specification of fuse cable is consistent with the input or output terminal of the battery charger.

# Recommended Cable and Fuse Sizing

## Recommended Fuse Sizing

For your safety, it is recommended to install fuses at both the input and output ends of the battery charger to ensure safe operations.

### NOTE

- The specifications of the fuse are determined by the solar panel and battery charger parameters.
- The output fuse is included in the accessories supplied with the battery charger.

Fuse from Solar Panel to Battery Charger	
Solar Panel to Battery Charger Fuse = Solar Panel / Solar Panel Array Total Amps * 1.56	
Solar Panels in Series	Solar Panels in Parallel
Total Amps: $I_{sc1} = I_{sc2} = I_{sc3}$ Fuse = $I_{sc1} * 1.56$	Total Amps: $I_{sc1} + I_{sc2} + I_{sc3}$ Fuse = $(I_{sc1} + I_{sc2} + I_{sc3}) * 1.56$

### INFO

- Read the user manual of the solar panel to obtain working voltage parameters, and calculate the corresponding fuse specifications according to the formula.



### NOTE

- In the formula,  $I_{sc}$  represents the rated current of the solar panel, and 1, 2 or 3 represents the solar panel number, respectively.

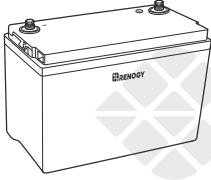
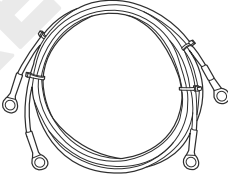

Fuse from Starter Battery to Battery Charger	
Renogy 12V 30A Dual Input DC-DC On-Board Battery Charger with MPPT (RBC30D1S)	45-60A
Renogy 12V 50A Dual Input DC-DC On-Board Battery Charger with MPPT (RBC50D1S)	75-100A

# Components & Tools

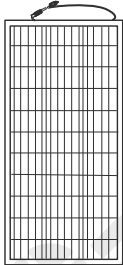
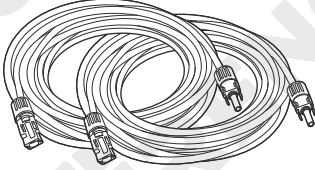
## Recommended Components

<p>Auxiliary Battery</p>	<p>Ring Terminals Adapter Cable</p>	<p>Fuse Cable</p>
		
<p>Solar Panel</p>		<p>Solar Panel Extension Cables</p>
		

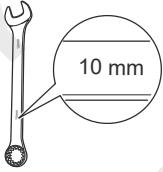
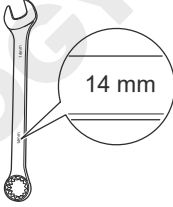
## Required Tools

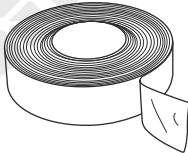
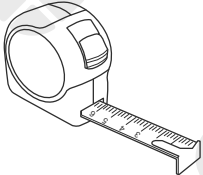
<p>Wrench (10 mm)</p>	<p>Wrench (14 mm)</p>	<p>Phillips Screwdriver (#2)</p>
		
<p>Insulation Tape</p>		<p>Measuring Tape</p>
		

# Preparation

## Checking Battery Charger

## Checking Auxiliary Battery

## Checking Solar Panel (Optional)

## Checking Automobile Alternator (Optional)

### NOTE

- The adapter cable used in this manual can be made by yourself or purchased from [renogy.com](http://renogy.com) according to the names in Recommended Components.

## Checking Battery Charger

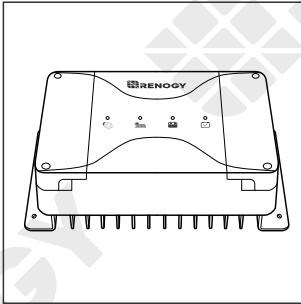

1. Inspect the battery charger for any visible damage including cracks, dents, deformation, and other visible abnormalities. All connector contacts shall be clean, free of dirt and corrosion, and dry.

### WARNING

- Do not use the battery charger if it has any visible damage.

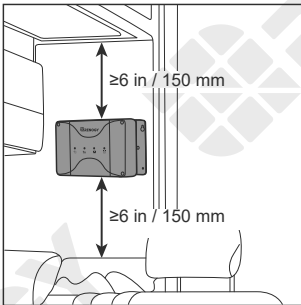

2. Confirm the installation location.

### WARNING

- Install the battery charger indoors and prevent its components from being exposed to direct sunlight. Prevent water from entering the battery charger.
- Risk of explosion! Never install the battery charger in a sealed enclosure with flooded batteries! Do not install it in a confined area where battery gases can accumulate.
- Place the battery charger on a vertical surface. Make sure there is good ventilation.
- The battery charger requires at least 6 inches (150 mm) of clearance above and below for good ventilation.
- Make sure that the battery charger is installed in an environment with relative humidity between 0% and 95% and no condensation.

# Preparation

## Checking Battery Charger

## Checking Auxiliary Battery

Checking Solar Panel (Optional)

Checking Automobile Alternator (Optional)

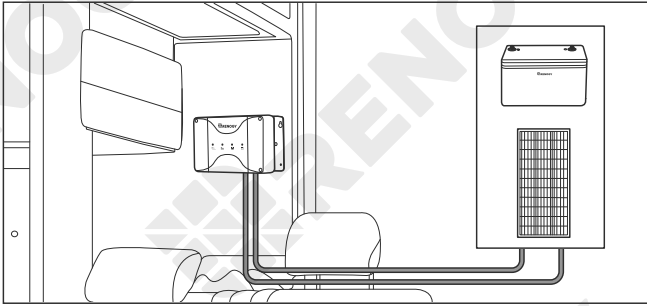

3. Measure whether the adapter cable is long enough to connect the battery charger.

### **i** NOTE

- If the adapter cable is not long enough, you can use an extension cable or reselect the position where the battery charger needs to be secured.

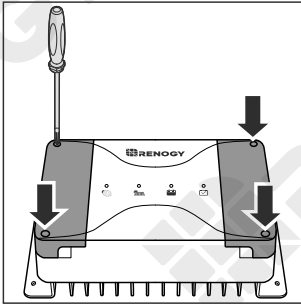

4. Remove the four screws on the protective cover and remove the cover with a phillips screwdriver.

## Checking Auxiliary Battery

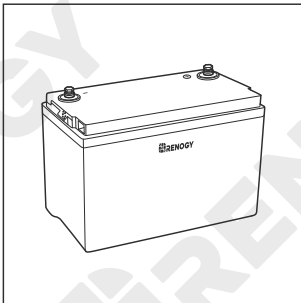

1. Inspect the auxiliary battery for any visible damage including cracks, dents, deformation, and other visible abnormalities. All connector contacts shall be clean, dry, and free of dirt and corrosion.

### **!** CAUTION

- The battery charger can only be applied to a deep-cycle sealed lead-acid battery, a flooded battery, an AGM battery, a gel battery or a lithium iron phosphate battery.
- The battery may produce explosive gases when being charged. Make sure there is good ventilation.

# Preparation

- Take care to use a high-capacity lead-acid battery. Be sure to wear protective goggles. If carelessly getting electrolyte in your eyes, flush your eyes with clean water immediately.

## WARNING

- Do not use the battery if it has any visible damage.
- Do not touch the exposed electrolyte or powder if the battery housing is damaged.

System Voltage	
Battery / Battery pack system voltage = System voltage U	
Batterys in Series	Batterys in Parallel
System Voltage U: $U_1+U_2+U_3$	System Voltage U: $U_1=U_2=U_3$

2. The batteries can be combined in parallel or in series as needed. This battery charger supports a maximum system voltage of 16V. Read the user manual for battery voltage parameters, and calculate the battery or battery pack system voltage according to the formula to ensure that it does not exceed 16V.

## NOTE

- In the formula, U represents the battery voltage, and 1, 2 or 3 represents the battery number, respectively.

## WARNING

- Do not use the battery charger if the battery or battery pack system voltage exceeds 16V. Doing so will cause damage to the battery charger.

## Checking Solar Panel (Optional)

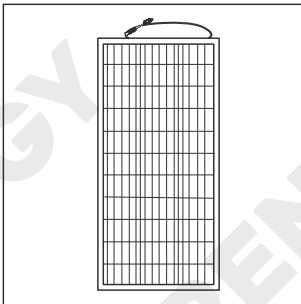

1. Inspect the solar panel for any visible damage including cracks, dents, deformation, and other visible abnormalities. All connector contacts shall be clean, dry, and free of dirt and corrosion.

## NOTE

- The solar panels can be combined in parallel or in series as needed.

## WARNING

- Do not use the solar panel if it has visible damage.

# Preparation

Checking Battery Charger

Checking Auxiliary Battery

Checking Solar Panel (Optional)

Checking Automobile Alternator (Optional)

- Cover the solar panels or turn them over before connecting them to the battery charger.

Working Voltage	
Working Voltage of Solar Panel / Solar Panel Array = Working Voltage U	
Solar Panels in Series	Solar Panels in Parallel
Working Voltage U: $U_1+U_2+U_3$	Working Voltage U: $U_1=U_2=U_3$

2. Read the user manual of the solar panel for the working voltage, and calculate the working voltage of solar panel / solar panel array according to the formula.

## NOTE

- In the formula, U represents the working voltage of the solar panel, and 1, 2 or 3 represents the solar panel number, respectively.

## WARNING

- Ensure that the working voltage of the solar panel / solar panel array does not exceed 15V.
- For a 30A battery charger, ensure that the working voltage of the solar panel / solar panel array does not exceed 30V. For a 50A battery charger, ensure that the working voltage of the solar panel / solar panel array does not exceed 50V.

Maximum Output Power	
Maximum Output Power of Solar Panel / Solar Panel Array= Maximum Output Power W	
Solar Panels in Series	Solar Panels in Parallel
Maximum Output Power W: $W_1+W_2+W_3$	Maximum Output Power W: $W_1+W_2+W_3$

3. Read the user manual of the solar panel for the maximum output power, and calculate the maximum output power of solar panel or solar panel array according to the formula.

## NOTE

- In the formula, W represents the maximum output power of the solar panel, and 1, 2, or 3 represents the solar panel number, respectively.

## WARNING

- For a 30A battery charger, ensure that the maximum output power of the solar panel does not exceed 400W. For a 50A battery charger, ensure that the maximum output power of the solar panel does not exceed 660W.

## Checking Automobile Alternator (Optional)

The automobile alternator may be a smart alternator or a traditional alternator.

The connection method of a smart alternator or a traditional alternator depends on its parameters. Before installing the battery charger, read the user manual of the vehicle or consult the vehicle supplier to determine the type of alternator.

In addition, you can use a multimeter by yourself to measure the alternator to determine the type of alternator.

1. Locate your main vehicle battery or the starter battery.
2. Start the engine. Ensure all any fans, radio, lights, and others are turned off.
3. Take a voltage reading across the main vehicle battery.
4. Leave the engine running for around 5 or 10 minutes, then repeat step 3.

If your readings are around 14.4V DC, then you most likely have a traditional alternator.

If your readings are around 12.5-13.5V, then you most likely have a smart alternator.



### WARNING

- In general, the working voltage of a traditional alternator ranges from 13.2V to 16V, and that of a smart alternator ranges from 12V to 16V.
- For a 30A battery charger, ensure that the maximum output power of the alternator does not exceed 400W. For a 50A battery charger, ensure that the maximum output power of the alternator does not exceed 660W.

To prevent overuse of the starter battery, it is essential to select the battery charger specification. The specification of the battery charger is no greater than 1.5-2 times the specification of the alternator.

The battery charger and the alternator are both specified in A (amperage), for example:

The specification of RBC30D1S is 30A and that of a alternator is 45A-60A.

The specification of RBC30D1S is 50A and that of a alternator is 75A-100A.

# Battery Charger Wiring

## CAUTION

- Do not overtorque the terminals on the battery charger.
- Do not connect the positive terminal first.

### 1. NEG- Terminal Wiring:

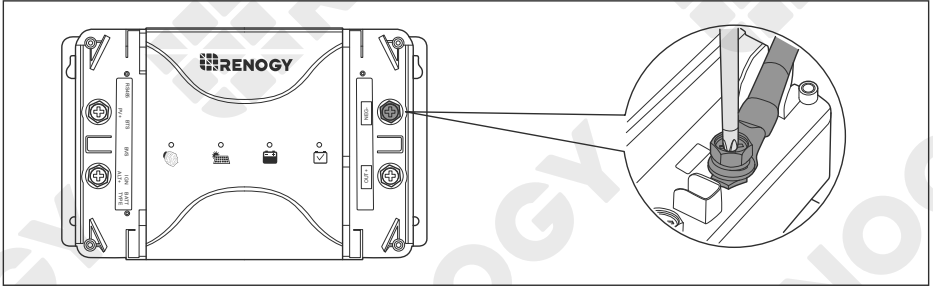

Connect the auxiliary battery to (NEG-) terminal of the battery charger.

## NOTE

- Connect the negative terminal of the solar panel and the negative terminal of the starter battery to the negative pole of the auxiliary battery.

### 2. Auxiliary Battery Positive Wiring:

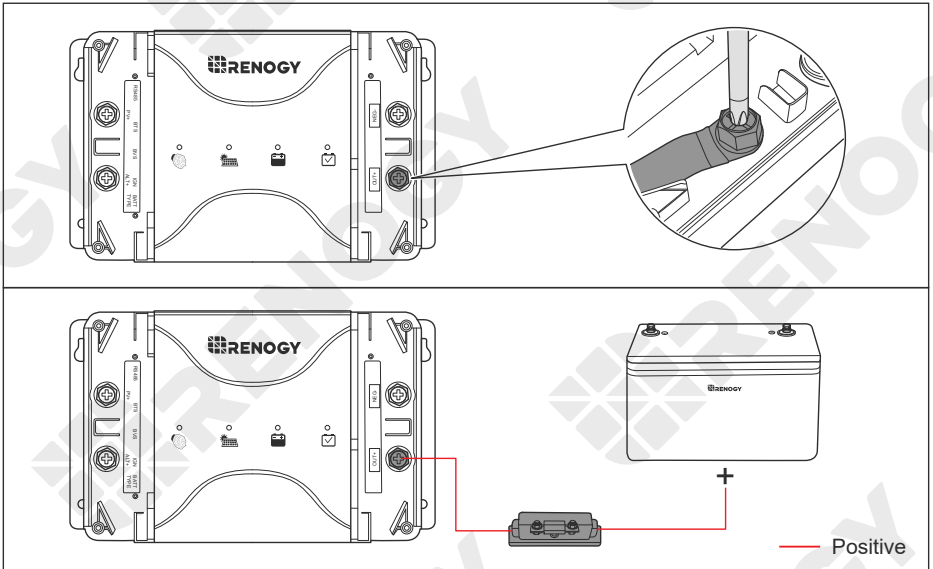

Connect the positive terminal of the auxiliary battery to one end of the fuse box. Connect the other end of the fuse box to the OUT+ terminal of the battery charger. Make sure all the terminals are tight and secure.

# Battery Charger Wiring

## 3. Solar Positive Wiring:

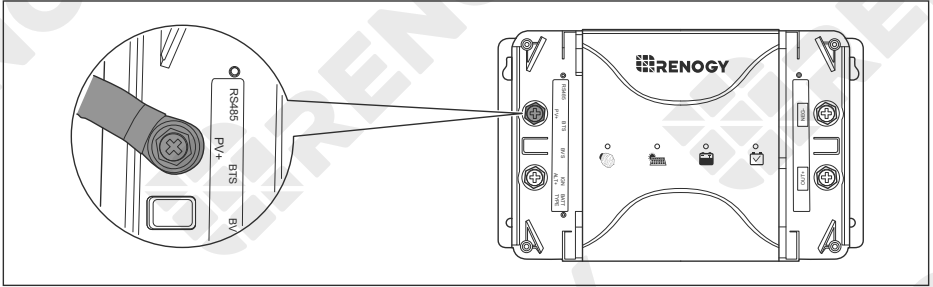

Connect the positive terminal of the solar panel to the Positive Solar Terminal (PV+) of the battery charger.

## 4. ALT Positive Wiring:

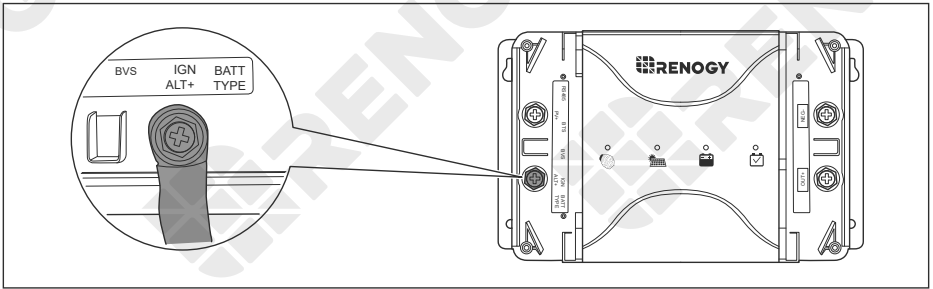

Connect the positive terminal of the starter battery to the Positive Starter Battery Terminal (ALT+).

## 5. For smart alternator only:

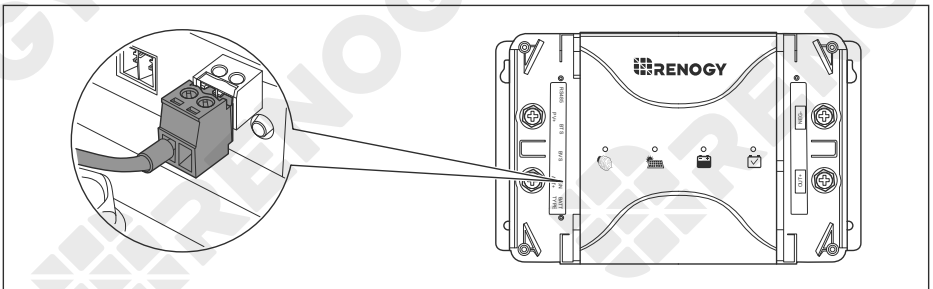

Insert the terminal block of the IGN Signal Wire to the Ignition Signal (IGN), and the bare wire terminal to the ignition of the vehicle.

### **i** NOTE

- The traditional alternator does not need to be connected to the IGN Signal Wire.

# Mounting

When selecting a location for the battery charger, make sure that the battery charger is as close as possible to the battery (auxiliary battery). The battery charger can be installed in the cabin of the vehicle, along the chassis rails, in the internal guard panel of the vehicle, behind the grille or headlights, or even on the side of the radiator. However, ensure that the area is not susceptible to moisture or other substances as well as potential high temperatures. It is recommended to ensure good ventilation for better operation of the battery charger.

## CAUTION

- Make sure that the battery charger is installed firmly to prevent it from falling off.

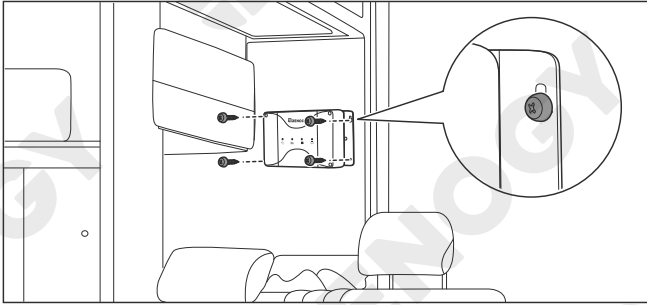

Place the battery charger against a flat surface and secure it with included screws.

# Temperature Sensor

The temperature sensor can detect the battery temperature and update it to the battery charger for charging voltage calibration. This ensures the battery charger (with operating temperature range from -31°F to 149°F or -35°C to 65°C) can charge the battery normally.



## CAUTION

- Do not use the temperature sensor on a LiFePO4 (LFP) battery which comes with a battery management system (BMS).

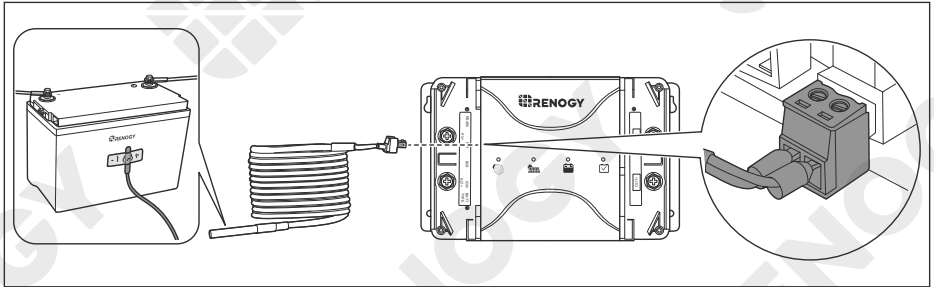

1. Insert the temperature sensor terminal block into the BTS port of the battery charger.
2. Adhere the sensor on the top or side of the battery with insulation tape.

# Voltage Sensor

The Battery Voltage Sensor is the perfect solution by providing an accurate battery voltage to the battery charger and allowing it to adjust the charging stage precisely resulting in overall extension of your battery life.

## NOTE

- Identify the polarities (positive and negative) on the cables used for the batteries. A reverse polarity contact may damage the battery charger.
- The voltage sensor ring terminal is M8 (Approx. 5/16"). If the battery bolt size is small, use a gasket to fix it to prevent it from falling off.

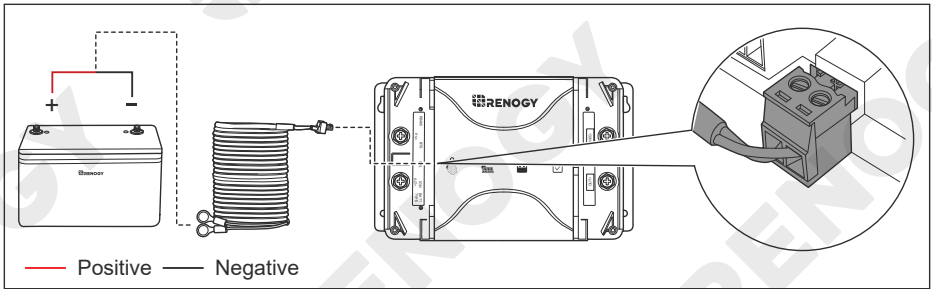

1. Insert the voltage sensor terminal block to the BVS port.
2. Connect the voltage sensor ring terminal to the positive and negative poles of the battery system.

# Communication

With a Renogy BT-2 Bluetooth Module (sold separately), the battery charger can be connected to the DC Home app for remote device monitoring.

The battery charger supports bluetooth for system monitoring and parameter modifying with the Renogy BT-2 Bluetooth Module.

## INFO

- Read the user manual of the Renogy BT-2 Bluetooth Module for more instructions.

## NOTE

- Make sure that the battery charger is turned on before connection.
- Scan the QR code on the last page of the user manual to download the DC Home app.

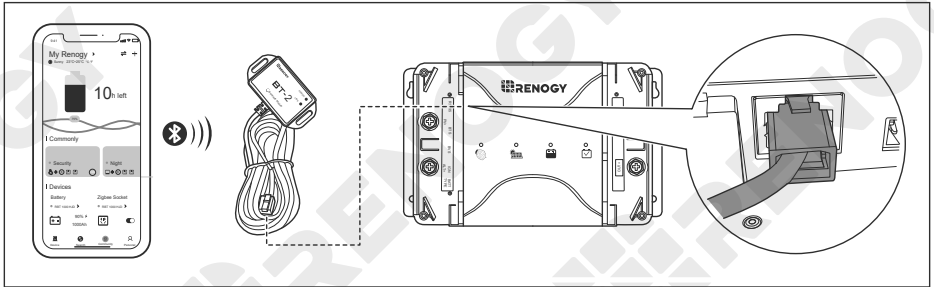

1. Power on the battery charger.
2. Connect the Bluetooth Module to the RS485 port on the bottom of the battery charger.
3. Connect the battery charger to the DC Home app.

# Operation

## Selecting the Battery Type

## Battery Charging Parameters

## User Mode

Manually set the battery type according to needs. The knob with 5 gears makes the selection of battery type more convenient.

In the DC Home app, you can also set the battery type. Check the operating status of the battery charger and modify some parameters. If you need to program multiple parameters of the battery, you can set the battery type in the user mode.

## Selecting the Battery Type

### WARNING

- Refer to battery manufacturer technical specifications when choosing a preset battery. Incorrect battery type selection resulting in damage will not be covered by warranty.

### Battery Type Setting Button

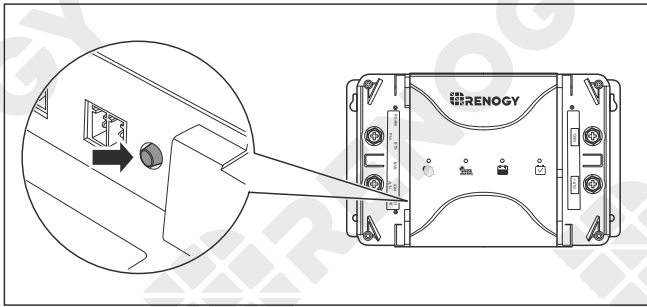

1. Press the Battery Type Setting Knob on the left side.

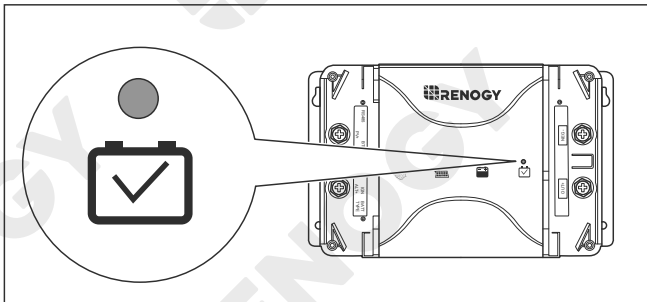

2. The Battery Type Indicator flashes different colors to represent different types of battery.

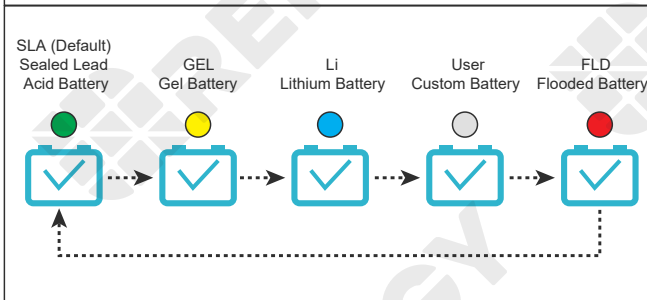

## DC Home app

### NOTE

- Make sure the Bluetooth of your phone is turned on.
- The version of the DC Home app might have been updated. Illustrations in the user manual are for reference only. Follow the instructions based on the current app version.

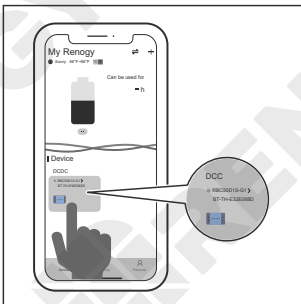
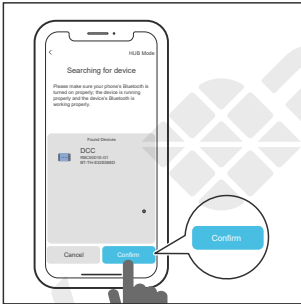
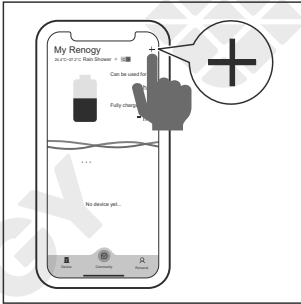

# Operation

## Selecting the Battery Type

Battery Charging Parameters

User Mode

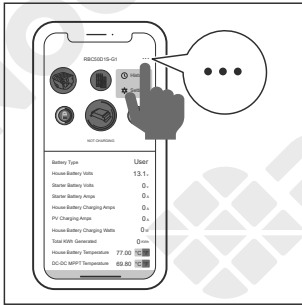

4. Tap **⋮** in the upper right corner.



5. Tap **Settings** to enter the mode selection interface.

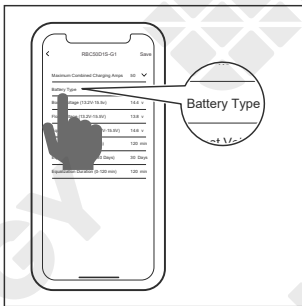

6. Tap **Battery Type**.

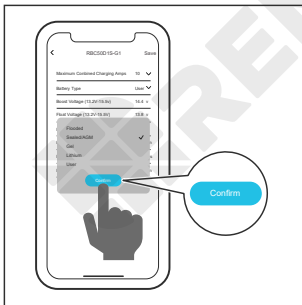

7. According to the actual usage, tap the option button that matches the auxiliary battery in this interface to complete the battery type setting.

## Battery Charging Parameters



### WARNING

- Before modifying battery parameters, check the table below. Incorrect parameter setting will damage the device and void the warranty.

Battery Type Parameters	AGM / SLD	Gel	Flooded	Li (LFP)	User-defined	User Setting Range
Overvoltage Shutdown	16.0V	16.0V	16.0V	16.0V	[16.0V]	—
Overvoltage Return	15.0V	15.0V	15.0V	15.4V	[15.4V]	—
Equalization Voltage	—	—	14.8V	—	14.6V	9.0-17.0V
Boost Voltage	14.6V	14.2V	14.6V	14.4V	14.4V	9.0-17.0V
Float Voltage	13.8V	13.8V	13.8V	—	13.8V	9.0-17.0V
Boost Return Voltage	13.2V	13.2V	13.2V	13.2V	13.2V	9.0-17.0V
Low Voltage Reconnect	12.6V	12.6V	12.6V	12.6V	[12.6V]	9.0-17.0V
Undervoltage Recover	12.2V	12.2V	12.2V	12.3V	[12.2V]	—
Undervoltage Warning	12.0V	12.0V	12.0V	12.1V	12.0V	9.0-17.0V
Low Voltage Shutdown	11.1V	11.1V	11.1V	11.1V	[11.1V]	9.0-17.0V
Boost Duration	120 min*	120 min*	120 min*	—	120 min*	10-300 min
Equalization Duration	—	120 min*	—	—	120 min*	0-300 min
Equalization Interval	0 days**	0 days**	28 days	—	30 days	0-250 days
Temperature Compensation	-3 mV / °C / 2V	-3 mV / °C / 2V	-3 mV / °C / 2V	—	-3 mV / °C / 2V	0 / 3 / 4 / 5 mV / °C / 2V



### CAUTION

- \* if the battery type is lead-acid battery and the charging current is less than 3A, the battery charger will automatically switch to float charging after 30 seconds.
- \*\* no Equalization Charging.
- Parameters in gray cannot be set manually
- Parameters in square brackets ([ ]) are automatically adjusted according to the relevant settings, and cannot be set directly.

## User Mode



### WARNING

- Before modifying battery parameters in user mode, check the table below and consult the battery manufacturer to check whether modification is allowed. Incorrect parameter setting will damage the device and void the warranty.

<b>Maximum Charging Current</b>	Renogy 12V 30A Dual Input DC-DC On-Board Battery Charger with MPPT (RBC30D1S)	
	Max. Charging Current: 30A	Adjustable Charging Current: 30A / 20A / 10A
	Renogy 12V 50A Dual Input DC-DC On-Board Battery Charger with MPPT (RBC50D1S)	
	Max. Charging Current: 50A	Adjustable Charging Current: 50A / 40A / 30A / 20A / 10A
<b>Equalization Voltage</b>	(1) For lead-acid batteries, please consult the battery manufacturer to obtain the voltage value, and then set the balance voltage according to the feedback. (2) If equalization charging is not required, set the voltage to boost voltage.	
<b>Boost Voltage</b>	Please consult the battery manufacturer and check if this voltage value needs to be set.	
<b>Float Voltage</b>		
<b>Boost Duration</b>	Please consult the battery manufacturer if it is necessary to set this parameter value.	
<b>Equalization Interval</b>		
<b>Equalization Duration</b>		

# Operation

## NOTE

- Make sure Bluetooth of your phone is turned on.
- The version of the DC Home app might have been updated. Illustrations in the user manual are for reference only. Follow the instructions based on the current app version.

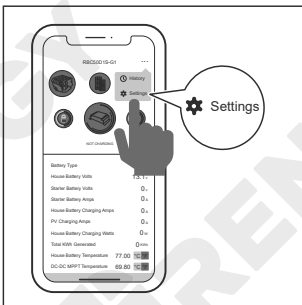
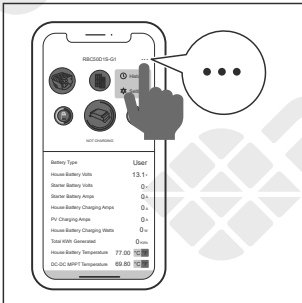
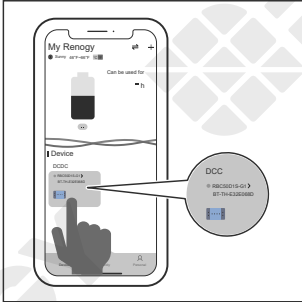

# Operation

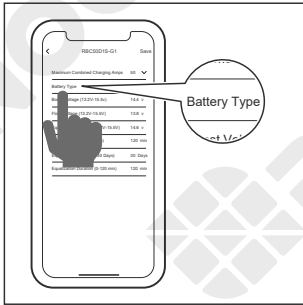

4. Tap **Battery Type**.

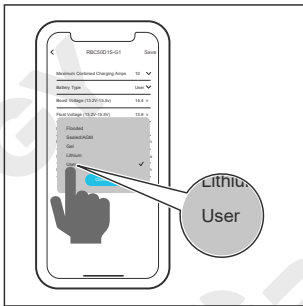

5. Tap **User** to enter the user-defined mode interface.

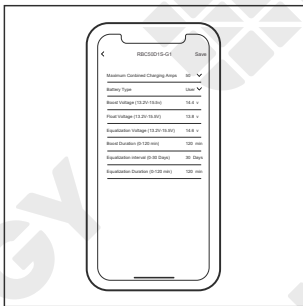

6. In this interface, you can customize multiple parameters of the battery. When the parameters are modified, Setting Success appears on the interface, indicating that the parameter setting is completed.

# Working Logic

To Solar Panel

To Starter Battery

To Both Solar Panel and Starter Battery

Renogy 12V 30A/50A Dual Input DC-DC On-Board Battery Charger with MPPT can be connected to the solar panel and the automobile starter battery simultaneously or to the solar panel or the automobile starter battery separately to charge the auxiliary battery. The charging logic depends on the connection method.

## To Solar Panel

### ■ Working conditions

Solar Panel Voltage	Battery Charger Status
$\geq 15.0V$ , for 10 seconds	Start Working
$< 15.0V$	Stop Working

When the output voltage of the solar panel is greater than or equal to 15V, the battery charger starts working after 10s. If the output voltage of the solar panel is less than 15V, the battery charger will stop working.

### ■ Charging Logic

After the battery charger starts to operate, it determines the level of the auxiliary battery automatically. If the auxiliary battery is not fully charged, the battery charger will charge the auxiliary battery.

Model	Charging Current
Renogy 12V 30A Dual Input DC-DC On-Board Battery Charger with MPPT (RBC30D1S)	$\leq 30A$ (from the solar panel)
Renogy 12V 50A Dual Input DC-DC On-Board Battery Charger with MPPT (RBC50D1S)	$\leq 50A$ (from the solar panel)

Renogy 12V 30A Dual Input DC-DC On-Board Battery Charger with MPPT provides the maximum current of 30A to charge the auxiliary battery.

Renogy 12V 50A Dual Input DC-DC On-Board Battery Charger with MPPT provides the maximum current of 50A to charge the auxiliary battery.

### NOTE

- The battery charger determines automatically that the auxiliary battery is fully charged if:
  - (1) The non-lithium battery enters float charging.
  - (2) The lithium battery maintains boost charging for 1 hour.
- When the auxiliary battery is fully charged, the battery charger activates the standby state.

### ■ Overvoltage protection

Renogy 12V 30A Dual Input DC-DC On-Board Battery Charger with MPPT: When the output voltage of the solar panel is greater than 30.5V, the battery charger will trigger the overvoltage protection and stop operating immediately, and will not operate until the output voltage of the solar panel is less than 29.5V.

Renogy 12V 50A Dual Input DC-DC On-Board Battery Charger with MPPT: When the output voltage of the solar panel is greater than 50.5V, the battery charger will trigger the overvoltage

# Working Logic

To Solar Panel

To Starter Battery

To Both Solar Panel and Starter Battery

protection and stop operating immediately, and will not operate until the output voltage of the solar panel is less than 49.5V.

## To Starter Battery

As the automobile alternator may be a smart alternator or a traditional alternator, the working conditions and charging logic of the battery charger depend on the connection method and the working voltage depends on the alternator.

### ■ Working conditions

Alternator Type	Starter Battery Voltage	
	Cut-in	Cut-off
Smart Alternator	>12.0V, for 15 seconds	<11.5V
Traditional Alternator	>13.2V, for 15 seconds	<12.7V

1. Smart alternator: When the battery charger tests that the voltage of the starter battery is greater than 12V, it pauses for 15s and then starts to work and charge the auxiliary battery.
2. Traditional alternator: When the battery charger tests that the voltage of the starter battery is greater than 13.2V, it pauses for 15s and then starts to work and charge the auxiliary battery.

### ■ Charging Logic

1. Smart alternator: After the battery charger starts to operate, it determines the level of the auxiliary battery automatically. If the auxiliary battery is not fully charged, the battery charger will charge the auxiliary battery. If the auxiliary battery is fully charged or the voltage of the starter battery is less than 11.5V, the battery charger will stop operating.
2. Traditional alternator: After the battery charger starts to operate, it determines the level of the auxiliary battery automatically. If the auxiliary battery is not fully charged, the battery charger will charge the auxiliary battery. If the auxiliary battery is fully charged or the voltage of the starter battery is less than 12.7V, the battery charger will stop operating.

Model	Charging Current
Renogy 12V 30A Dual Input DC-DC On-Board Battery Charger with MPPT (RBC30D1S)	≤30A (from the starter battery)
Renogy 12V 50A Dual Input DC-DC On-Board Battery Charger with MPPT (RBC50D1S)	≤50A (from the starter battery)

Renogy 12V 30A Dual Input DC-DC On-Board Battery Charger with MPPT provides the maximum current of 30A to charge the auxiliary battery.

Renogy 12V 50A Dual Input DC-DC On-Board Battery Charger with MPPT provides the maximum current of 50A to charge the auxiliary battery.

### NOTE

- The battery charger determines automatically that the auxiliary battery is fully charged if:
  - (1) The non-lithium battery enters float charging.

# Working Logic

To Solar Panel

To Starter Battery

To Both Solar Panel and Starter Battery

(2) The lithium battery maintains boost charging for 1 hour.

- When the auxiliary battery is fully charged, the battery charger activates the standby state.

## ■ Overvoltage protection

When the voltage of the starter battery is greater than 16.5V, the battery charger triggers overvoltage protection and stops operating immediately. The battery charger will not operate until the voltage of the battery is less than 15.5V.

## To Both Solar Panel and Starter Battery

When the input terminal of the battery charger is connected to the solar panel and the starter battery at the same time, if the output voltage of the solar panel meets the working conditions of the battery charger, the battery charger will charge the battery with the solar panel first.

If the solar panel fails to keep the auxiliary battery fully charged, the battery charger will adjust automatically to allow both the solar panel and the starter battery to charge the auxiliary battery at the same time.

## Prioritizing the solar panel to generate electricity alone

### ■ Working conditions

Model	Working Condition	Starter battery state	Solar Panel Output Current	Auxiliary Battery Voltage	Auxiliary Battery Charging
RBC30D1S	Separate solar work	Smart: >12V Traditional: >13.2V	≥15A	≥13.2V	• Lithium battery: boost charging • Non-lithium battery: float charging
		Smart: <11.5V Traditional: <12.7V			
RBC50D1S		Smart: >12V Traditional: >13.2V	≥25A		
		Smart: <11.5V Traditional: <12.7V			

Renogy 12V 30A Dual Input DC-DC On-Board Battery Charger with MPPT: When the solar panel provides more than 15A to charge the auxiliary battery and the voltage of the auxiliary battery is greater than or equal to 13.2V, only the solar panel charges the battery charger.

Renogy 12V 50A Dual Input DC-DC On-Board Battery Charger with MPPT: When the solar panel provides more than 25A to charge the auxiliary battery and the voltage of the auxiliary battery is greater than or equal to 13.2V, only the solar panel charges the battery charger.

## NOTE

- If both the solar panel and the starter battery fail to meet the working conditions, the battery charger will stop operating.

# Working Logic

To Solar Panel

To Starter Battery

To Both Solar Panel and Starter Battery

## ■ Charging Logic

1. Charging the auxiliary battery: After the battery charger starts to operate, it determines the level of the auxiliary battery automatically. If the auxiliary battery is not fully charged, the battery charger charges it only.

Model	Charging Current
Renogy 12V 30A Dual Input DC-DC On-Board Battery Charger with MPPT (RBC30D1S)	≤30A (from the solar panel)
Renogy 12V 50A Dual Input DC-DC On-Board Battery Charger with MPPT (RBC50D1S)	≤50A (from the solar panel)

Renogy 12V 30A Dual Input DC-DC On-Board Battery Charger with MPPT provides the maximum current of 30A to charge the auxiliary battery.

Renogy 12V 50A Dual Input DC-DC On-Board Battery Charger with MPPT provides the maximum current of 50A to charge the auxiliary battery.

2. Charging a starter battery: when the battery charger determines that the auxiliary battery is fully charged automatically, it starts to charge the starter battery while maintaining a very small current to continue charging the auxiliary battery.

The maximum charging current for the battery charger to charge the starter battery should be no more than half of the rated current.

Model	Charging Current
Renogy 12V 30A Dual Input DC-DC On-Board Battery Charger with MPPT (RBC30D1S)	≤15A (from the solar panel)
Renogy 12V 50A Dual Input DC-DC On-Board Battery Charger with MPPT (RBC50D1S)	≤25A (from the solar panel)

Renogy 12V 30A Dual Input DC-DC On-Board Battery Charger with MPPT provides the maximum charging current of 15A to charge the starter battery.

Renogy 12V 50A Dual Input DC-DC On-Board Battery Charger with MPPT provides the maximum charging current of 25A to charge the starter battery.

## NOTE

- The battery charger will charge the starter battery only when the auxiliary battery is fully charged.
- The battery charger determines automatically that the auxiliary battery is fully charged if:
  - (1) The non-lithium battery enters float charging.
  - (2) The lithium battery maintains boost charging for 1 hour.
- The battery charger will charge the starter battery for 1min and then stop charging for 30s. During this period, the battery charger will test the voltage of the starter battery automatically. If the voltage is greater than 13.2V, the battery charger will stop charging the starter battery and activate the standby state. If the voltage of the starter battery is less than 13.2V, the battery charger will continue to

# Working Logic

To Solar Panel

To Starter Battery

To Both Solar Panel and Starter Battery

charge the starter battery for 1min and then stop charging for 30s. The battery charger will check the voltage of the starter battery again until the voltage of the starter battery is greater than 13.2V.

- When the battery charger charges the starter battery, the starter battery can be charged up to 13.8V.
- When both the auxiliary battery and the starter battery are fully charged, the battery charger activates the standby state.

## ■ Overvoltage protection

Renogy 12V 30A Dual Input DC-DC On-Board Battery Charger with MPPT: When the output voltage of the solar panel is greater than 30.5V, the battery charger will trigger the overvoltage protection and stop operating immediately, and will not operate until the output voltage of the solar panel is less than 29.5V.

Renogy 12V 50A Dual Input DC-DC On-Board Battery Charger with MPPT: When the output voltage of the solar panel is greater than 50.5V, the battery charger will trigger the overvoltage protection and stop operating immediately, and will not operate until the output voltage of the solar panel is less than 49.5V.

# Working Logic

To Solar Panel

To Starter Battery

To Both Solar Panel and Starter Battery

## Hybrid charging of the solar panel and the starter battery

### ■ Working conditions

Model	Working Condition	Starter Battery	Solar Panel Output Current	Auxiliary Battery Voltage	Auxiliary Battery Charging
Renogy 12V 30A Dual Input DC-DC On-Board Battery Charger with MPPT (RBC30D1S)	Hybrid charging of the solar panel and the starter battery	Smart: >12V Traditional: >13.2V	<15A	≥13.2V	<ul style="list-style-type: none"> <li>Lithium battery: boost charging</li> <li>Non-lithium battery: float charging</li> </ul>
			≥15A	<13.2V	<ul style="list-style-type: none"> <li>Lithium battery: boost charging</li> <li>Non-lithium battery: float charging</li> </ul>
			≥15A	≥13.2V	<ul style="list-style-type: none"> <li>Lithium battery: Non-boost charging</li> <li>Non-lithium battery: Non-float charging</li> </ul>
Renogy 12V 50A Dual Input DC-DC On-Board Battery Charger with MPPT (RBC50D1S)			<25A	≥13.2V	<ul style="list-style-type: none"> <li>Lithium battery: boost charging</li> <li>Non-lithium battery: float charging</li> </ul>
			≥25A	<13.2V	<ul style="list-style-type: none"> <li>Lithium battery: boost charging</li> <li>Non-lithium battery: float charging</li> </ul>
			≥25A	≥13.2V	<ul style="list-style-type: none"> <li>Lithium battery: Non-boost charging</li> <li>Non-lithium battery: Non-float charging</li> </ul>

When the battery charger determines automatically that the power supply of the solar panel is insufficient, the battery charger will adjust automatically to allow both the solar panel and the starter battery to charge the auxiliary battery.

The battery charger determines automatically that the power supply of the solar panel is insufficient if one of the following conditions occurs:

- Renogy 12V 30A Dual Input DC-DC On-Board Battery Charger with MPPT:
  - The output current of the solar panel is less than 15A.
  - The voltage of the auxiliary battery is less than 13.2V.
  - The state of charge of the auxiliary battery is non-boost / non-float.

# Working Logic

To Solar Panel

To Starter Battery

To Both Solar Panel and Starter Battery

2. Renogy 12V 50A Dual Input DC-DC On-Board Battery Charger with MPPT:
  - (1) The output current of the solar panel is less than 25A.
  - (2) The voltage of the auxiliary battery is less than 13.2V.
  - (3) The state of charge of the auxiliary battery is non-boost / non-float.

## NOTE

- If the output voltage of the starter battery fails to meet the working conditions of the battery charger, the battery charger cannot switch to the hybrid charging mode, so that it adjusts automatically to use only the solar panel to charge the auxiliary battery.
- The starter battery fails to meet the working conditions of the battery charger if one of the following conditions occurs:
  - (1) For smart alternator: The voltage of the starter battery is less than 11.5V.
  - (2) For traditional alternator: The voltage of the starter battery is less than 12.7V.
- In the hybrid charging mode, if the solar panel meets the working conditions, the battery charger adjusts automatically to use the solar panel only to charge the auxiliary battery.
- If neither the solar panel nor the starter battery meets the working conditions, the battery charger stops operating.

## ■ Charging Logic

When both the solar panel and the starter battery charge the auxiliary battery at the same time, each can provide a charging current of at most half of the rated current to charge the auxiliary battery at the same time.

Model	Charging Current
Renogy 12V 30A Dual Input DC-DC On-Board Battery Charger with MPPT (RBC30D1S)	≤15A (from the solar panel) ≤15A (from the starter battery)
Renogy 12V 50A Dual Input DC-DC On-Board Battery Charger with MPPT (RBC50D1S)	≤25A (from the solar panel) ≤25A (from the starter battery)

Renogy 12V 30A Dual Input DC-DC On-Board Battery Charger with MPPT provides the maximum charging current of 15A from the solar panel, and the maximum charging current of 15A from the starter battery to charge the auxiliary battery.

Renogy 12V 50A Dual Input DC-DC On-Board Battery Charger with MPPT provides the maximum charging current of 25A from the solar panel, and the maximum charging current of 25A from the starter battery to charge the auxiliary battery.

## NOTE

- In the process of hybrid charging, if the starter battery voltage drops to a standard value which is below the working conditions of the battery charger, the battery charger will adjust automatically to use the solar panel to charge the auxiliary battery alone.
- When the auxiliary battery is fully charged, the battery charger adjusts automatically to use the solar panel to charge the starter battery. If both the auxiliary battery and the starter battery are fully charged, the battery charger activates the standby state.
- The battery charger recognizes automatically that the auxiliary battery is fully charged if:

# Working Logic

To Solar Panel

To Starter Battery

To Both Solar Panel and Starter Battery

- (1) The non-lithium battery enters float charging.
- (2) The lithium battery maintains boost charging for 1 hour.

## ■ Over-voltage protection

Renogy 12V 30A Dual Input DC-DC On-Board Battery Charger with MPPT: When the output voltage of the solar panel is greater than 30.5V, the battery charger will trigger the overvoltage protection and stop operating immediately, and will not operate until the output voltage of the solar panel is less than 29.5V.

Renogy 12V 50A Dual Input DC-DC On-Board Battery Charger with MPPT: When the output voltage of the solar panel is greater than 50.5V, the battery charger will trigger the overvoltage protection and stop operating immediately, and will not operate until the output voltage of the solar panel is less than 49.5V.

When the voltage of the starter battery is greater than 16.5V, the battery charger triggers over-voltage protection and stops operating immediately. The battery charger will not operate until the voltage of the battery is less than 15.5V.

## Low current cut-off mode

### ■ Working conditions

When the output current of the solar panel is less than 7A, the battery charger will automatically enter the low current cut-off mode and switch to charging only with the alternator.

Scan the QR code at the end of the manual to download the DC Home app. Through the app, you can set the low-current cut-off mode. You can also change the range of the low-current cut-off value of the solar panel. It is recommended to set it to 7-10A. If the value is set to 0A, the low current cut-off mode will be turned off.

After the low current cut-off mode is set and activated, when the output current of the solar panel is less than the set value, the battery charger activates the battery charging mode only.

### ■ Exit conditions

After the battery charging mode activates for 5 minutes, the battery charger judges the charging current of the solar panel again.

If the low current cut-off value < charging current ≤ half of the rated current lasts for 10s continuously, the battery charger will return to the simultaneous charging mode of both the solar panel and the starter battery.



If the charging current is greater than or equal to half of the rated current and the auxiliary battery is set in the float or boost stage, the battery charger will return to the independent charging mode of the solar panel.

# LED Indicators



Alternator / Charging Indicator

Battery Type Indicator







## Alternator / Charging Indicator

Color	Status	Description
Red  	ON	The alternator is charging the auxiliary battery.
	Slow Flashing	The Positive Solar Terminal is charging the starter battery.
	OFF	Not charging

## Solar Charging Indicator

Color	Status	Description
Red  	ON	Bulk charge (MPPT)
	Slow Flashing	Boost charge
	Single Flashing	Float charge
	Fast Flashing	Equalization charging
	Double Flashing	Current-limit Charging
	OFF	Not charging





## Auxiliary Battery Indicator

Color	Status	Description
Green  	ON	Full
Yellow  	ON	Normal voltage
Red  	ON	Undervoltage
	Slow Flashing	Overdischarge
	Fast Flashing	Overvoltage / Overtemperature

# LED Indicators

Alternator / Charging Indicator

Battery Type Indicator

Battery Type Indicator		
Color	Status	Description
Green 	ON	SLA (Default) - Sealed Lead Acid Battery
Yellow 	ON	Gel - Gel Battery
Blue 	ON	Li - Lithium Battery
White 	ON	User - User-defined Battery
Red 	ON	FLD - Flooded Battery

# Troubleshooting

## Alternator / Charging Indicator

## Solar Charging Indicator

## Auxiliary Battery Indicator

### Alternator / Charging Indicator

Color	Status	Description
	OFF	<p>For a traditional alternator, check the alternator input voltage. Measure it with a multimeter. Ensure that the voltage is greater than or equal to 13.2V.</p> <p>For a smart alternator, check the alternator input voltage. Measure it with a multimeter. Ensure that the voltage is greater than or equal to 12V.</p> <p>Ensure that the IGN Signal Wire, cables, and fuses are intact and properly connected.</p>

### Solar Charging Indicator

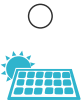
Color	Status	Description
	OFF	<p>Ensure that the solar panel is not being shaded (by a tree etc.). Ensure the voltage of the solar panel is higher than 15V with a multi-meter and check the electric connections.</p>

### Auxiliary Battery Indicator

Color	Status	Description
	Solid Red	<p>Turn off any loads connected to the battery and recharge the auxiliary battery.</p>
	Fast Flashing Red	<p>Ensure that the voltage of the auxiliary battery is 12V.</p> <p>Ensure the installation site is well ventilated. Avoid additional heating of the battery.</p> <p>Disconnect all loads and chargers from the battery and allow the battery temperature to decrease to operational specifications.</p>
	Slow Flashing Red	<p>Ensure that cables and fuses are intact and properly connected.</p> <p>Turn off any loads connected to the battery and recharge the auxiliary battery.</p>

# Technical Specifications

Product	RBC30D1S	RBC50D1S
System Voltage	12V DC	
Battery Voltage Range	9V to 16V DC	
Maximum Charging Current	30A	50A
Battery Type	SLA, Gel, FLD, Li, User-defined	
Auxiliary Battery Charging Mode	MPPT	
Charging Efficiency	Up to 97%	
Max. Solar Input Voltage	30V	50V
Max. Solar Input Power	400W	660W
Alternator Input Voltage	Traditional Alternator: 13.2V to 16V DC Smart Alternator (Euro 6): 12V to 16V DC	
Max. Alternator Input Power	400W	660W
Temp. Compensation Coefficient	-3mV / °C / 2V	
Self-consumption	< 30mA	
Operating Temperature Range	-31°F to 149°F / -35°C to 65°C	
Storage Temperature Range	-40°F to 176°F / -40°C to 80°C	
Humidity Range	0% to 95% (NC)	
Dimensions	9.61 x 5.75 x 3.03 in 244 x 146 x 77 mm	9.61 x 5.75 x 3.78 in 244 x 146 x 96 mm
Weight	3.11 lb / 1.41 kg	4.10 lb / 1.86 kg
Terminal Size	M8x1.25-14 mm	
Communication Protocol	RS485	
Grounding	Common Negative	
Certifications	CE; ROHS; FCC Part 15 Class B; ETL listed to UL1741 & CSA C22.2	

# Dimensions

## NOTE

- Dimension tolerance:  $\pm 0.2$  in (0.5 mm)

### ■ Renogy 12V 30A Dual Input DC-DC On-Board Battery Charger with MPPT (RBC30D1S)

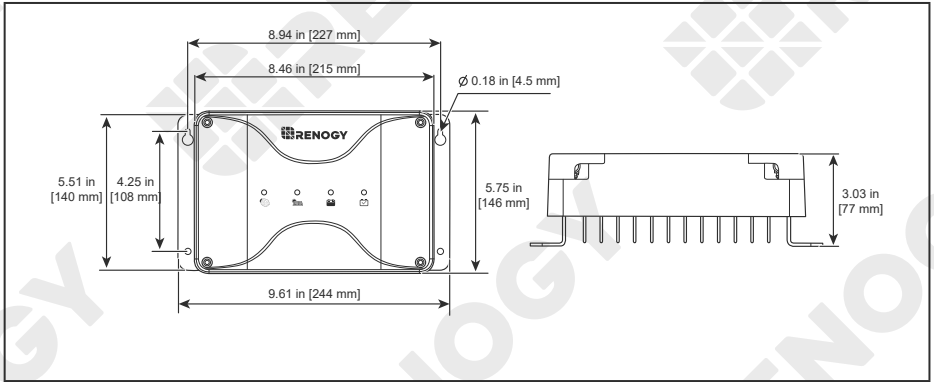

### ■ Renogy 12V 50A Dual Input DC-DC On-Board Battery Charger with MPPT (RBC50D1S)

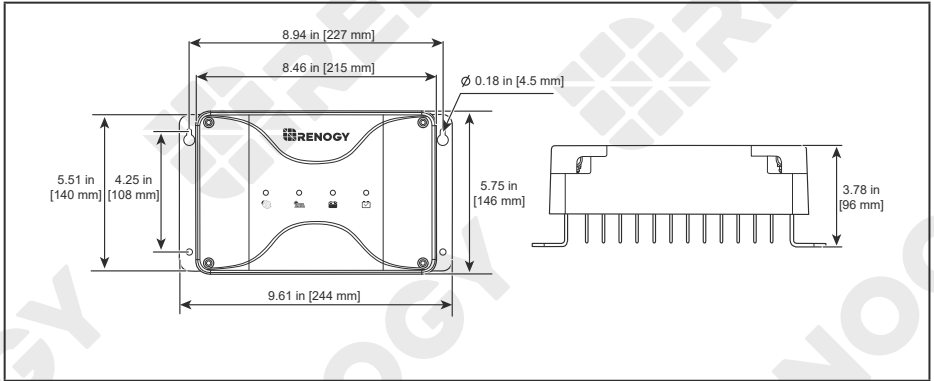

# Maintenance

Inspection

Cleaning

Storage

## Inspection

For optimum performance, it is recommended to perform these tasks regularly.

- Check the appearance of the battery charger to make sure it is clean and dry.
- Ensure the battery charger is installed in a clean, dry and ventilated area.
- Ensure the firmness of all cables and check if there are any loose, damaged or burnt connections.
- Make sure that all indicators are in normal state.
- Ensure there is no corrosion, insulation damage, or discoloration marks of overheating or burning.

### NOTE

- In some applications, corrosion may exist around the contacts.  
Corrosion can loosen springs and increase resistance, leading to premature connection failure. Apply dielectric grease to each connector contact periodically. Dielectric grease repels moisture and protects the connector contacts from corrosion.



### WARNING

- Risk of electric shock! Make sure that all power is turned off before touching the terminals on the battery charger.

## Cleaning

Follow the steps below to clean the battery charger regularly.

- Disconnect all cables that are connected to the battery charger.
- Wipe the housing of the battery charger and connector contacts with a dry cloth or non-metallic brush. If it is still dirty, you can use household cleaners.
- Dry the battery charger with a clean cloth and keep the area around the charger clean and dry.
- Make sure the battery charger is completely dry before reconnection.
- When reconnecting, follow the steps in the user manual.

## Storage

Follow the tips below to ensure that the battery charger is stored well.

- Disconnect all cables that are connected to the battery charger.
- By applying dielectric grease to each connector contact, the dielectric grease repels moisture and protects the connector contacts from corrosion.
- Store the battery charger in a well-ventilated, dry and clean environment with a temperature between -40° F and 176° F or -40° C to 80° C.

# Emergency Responses

Fire

Flooding

Smell

Noise

In the event of any threat to health or safety, always begin with the steps below before addressing other suggestions.

- Immediately contact the fire department or other relevant emergency response team.
- Notify all people who might be affected and ensure that they can evacuate the area.



## WARNING

- ONLY perform the suggested actions below if it is safe to do so.

### Fire

1. Disconnect all cables connected to the battery charger.
2. Put out the fire with a fire extinguisher. Acceptable fire extinguishers include water, CO<sub>2</sub>, and ABC.



## WARNING

- Do not use type D (flammable metal) fire extinguishers.

### Flooding

1. If the battery charger is submerged in water, stay away from the water.
2. Disconnect all cables connected to the battery charger.

### Smell

1. Disconnect all cables connected to the battery charger.
2. Make sure nothing is in contact with the battery charger.
3. Ventilate the room.

### Noise

1. Disconnect all cables connected to the battery charger.
2. Make sure no foreign objects are stuck in the battery charger ports.

# Technical Support

For additional support, contact the Renogy technical support team through [renogy.com/contact-us/](https://www.renogy.com/contact-us/). Have the following information available when contacting Renogy.

- Owner name
- Contact information
- Order number
- Purchase channel
- Serial number
- Brief description of the issue



**Renogy offers premium services worldwide:**

North America	US	<a href="https://www.renogy.com">www.renogy.com</a>	CN	<a href="https://www.renogy.cn">www.renogy.cn</a>
Asia / Pacific	UK	<a href="https://uk.renogy.com">uk.renogy.com</a>	CA	<a href="https://ca.renogy.com">ca.renogy.com</a>
	AU	<a href="https://au.renogy.com">au.renogy.com</a>	JP	<a href="https://renogy.jp">renogy.jp</a>
Europe	FR	<a href="https://fr.renogy.com">fr.renogy.com</a>	DE	<a href="https://de.renogy.com">de.renogy.com</a>
	ES	<a href="https://es.renogy.com">es.renogy.com</a>	KR	<a href="https://kr.renogy.com">kr.renogy.com</a>

## FCC Statement

This device complies with Part 15 of the FCC Rules. Operation is subject to the following two conditions:

- (1) This device may not cause harmful interference;
- (2) This device must accept any interference received, including interference that may cause undesired operation.

This equipment has been tested and found to comply with the limits for a Class B digital device, pursuant to Part 15 of the FCC Rules. These limits are designed to provide reasonable protection against harmful interference in a residential installation. This equipment generates uses and can radiate radio frequency energy and, if not installed and used in accordance with the instructions, may cause harmful interference to radio communications. However, there is no guarantee that interference will not occur in a particular installation. If this equipment does cause harmful interference to radio or television reception, which can be determined by turning the equipment off and on, the user is encouraged to try to correct the interference by one or more of the following measures:

- (1) Orient or relocate the receiving antenna.
- (2) Increase the separation between the equipment and receiver.
- (3) Connect the equipment into an outlet on a circuit different from that to which the receiver is connected.
- (4) Consult the dealer or an experienced radio / TV technician for help.

## FCC Radiation Exposure Statement

This equipment complies with FCC radiation exposure limits set forth for an uncontrolled environment. This equipment should be installed and operated with minimum distance 20 cm between the radiator & your body.



## Renogy Empowered

Renogy aims to empower people around the world through distribution of DIY-friendly renewable energy solutions.

We intend to be a driving force for sustainable living and energy independence.

In support of this effort, our range of solar products makes it possible for you to minimize your carbon footprint by reducing the need for grid power.



## Live Sustainably with Renogy

Did you know? In a given month, a 1KW solar energy system will...



Save 170 pounds of coal from being burned



Save 300 pounds of CO<sub>2</sub> from being released into the atmosphere



Save 105 gallons of water from being consumed



## Renogy Power **PLUS**

Renogy Power Plus allows you to stay in the loop with upcoming solar energy innovations, share your experiences with your solar energy journey, and connect with like-minded people who are changing the world in the Renogy Power Plus community.

Also, follow us on Youtube @Renogy Solar, Facebook @Renogy, and Instagram @renogyofficial.

Visit [renogy.com](https://renogy.com) to find relevant documentation or get more support via "[Contact Us](#)".  
Renogy reserves the right to change the contents of this manual without notice.

Manufacturer: RENOLOGY New Energy Co.,Ltd  
Address: No.66, East Ningbo Road Room 624-625  
Taicang German Overseas Students Pioneer Park  
JiangSu 215000 CN



eVatmaster Consulting GmbH  
Battinastr.30  
60325 Frankfurt am Main, Germany  
contact@evatmaster.com

Manufacturer: RENOLOGY New Energy Co.,Ltd  
Address: No.66, East Ningbo Road Room 624-625  
Taicang German Overseas Students Pioneer Park  
JiangSu 215000 CN



EVATOST CONSULTING LTD  
Suite 11, First Floor, Moy Road Business  
Centre, Taffs Well, Cardiff, Wales, CF15 7QR  
contact@evatmaster.com

Join the Renogy Power Plus Community  
by downloading the DC Home app.  
Find your e-warranty here, and more.

