

GAS CONVERSION KIT INSTALLATION FOR UNIT HEATERS

MODELS UDBP AND UBX: STANDARD POWER VENT BLOWER TYPE
MODELS UDDBS AND UBZ: SEPARATED-COMBUSTION BLOWER TYPE
MODELS UDAP AND UDX: STANDARD POWER VENT FAN TYPE
MODELS UDAS AND Udz: SEPARATED-COMBUSTION FAN TYPE

GENERAL INFORMATION

These gas conversion kits are for standard power vent or separated-combustion heaters equipped with either a single-stage or two-stage gas valve.

Model Identification

When converting fuels, it is necessary to have the complete heater model. The identifying model number can be found on the heater rating plate. The rating plate identifies only original equipment so also compare the label on the gas valve with the description listed.

⚠ DANGER ⚠

FIRE OR EXPLOSION HAZARD

- Failure to follow safety warnings exactly could result in serious injury, death, or property damage.
- Improper installation, adjustment, alteration, service, or maintenance can cause serious injury, death, or property damage.
- Installation and service must be performed by a qualified installer, service agency, or the gas supplier.
- Do not store or use gasoline or other flammable vapors and liquids in the vicinity of this or any other appliance.

WHAT TO DO IF YOU SMELL GAS

- Do not try to light any appliance.
- Do not touch any electrical switch; do not use any phone in your building.
- Leave the building immediately.
- Immediately call your gas supplier from a neighbor's phone. Follow the gas supplier's instructions.
- If you cannot reach your gas supplier, call the fire department.

DO NOT DESTROY. PLEASE READ CAREFULLY. KEEP IN A SAFE PLACE FOR FUTURE REFERENCE.

GENERAL INFORMATION—CONTINUED

Important Safety Information

Please read all information in this manual thoroughly and become familiar with the capabilities and use of your appliance before attempting to operate or maintain this unit. Pay attention to all dangers, warnings, cautions, and notes highlighted in this manual. Safety markings should not be ignored and are used frequently throughout to designate a degree or level of seriousness.

DANGER: A danger statement describes a potentially hazardous situation that if not avoided, will result in severe personal injury or death and/or property damage.

WARNING: A warning statement describes a potentially hazardous situation that if not avoided, can result in severe personal injury and/or property damage.

CAUTION: A caution statement describes a potentially hazardous situation that if not avoided, can result in minor or moderate personal injury and/or property damage.

NOTE: A note provides important information that should not be ignored.

⚠ DANGER ⚠

- **All gas conversion must be done by a qualified service person in accordance with these instructions and in compliance with all codes and requirements. In Canada, gas conversion shall be carried out in accordance with the requirements of the Provincial Authorities having jurisdiction and in accordance with the requirements of the CAN/CGA-B149.1 and CAN/CGA-B149.2 installation code.**
 - **The gas burner in this gas-fired equipment is designed to provide safe complete combustion. However, if the installation does not permit the burner to receive the proper supply of combustion air, complete combustion may not occur. The result is incomplete combustion, which produces carbon monoxide, a poisonous gas that can cause death.**
 - **Safe operation of indirect-fired gas burning equipment requires a properly operating vent system which vents all flue products to the outside atmosphere. Failure to provide proper venting will result in a health hazard that could cause serious personal injury or death.**
 - **On separated combustion heaters, install either the horizontal or vertical combustion air/vent system illustrated in the heater venting manual, using the concentric adapter supplied. For all heater installations, always comply with the combustion air requirements in the installation codes and instructions. Standard Power Vent heaters installed in a confined space must be supplied with air for combustion as required by Code and in the heater installation manual. Combustion air at the burner should be regulated only by manufacturer-provided equipment. Never restrict or otherwise alter the supply of combustion air to any heater. Maintain the vent or vent/combustion air system in structurally sound and proper operating condition.**
 - **Improper installation, adjustment, alteration, service, or maintenance can cause property damage, injury, or death. Read the installation, operation and maintenance instructions thoroughly before installing or servicing this equipment.**
 - **The conversion kit is to be selected and installed by a qualified service person in accordance with these instructions and in compliance with all codes and requirements of authorities having jurisdiction. Failure to follow instructions could result in death, serious injury, and/or property damage. The qualified agency performing this work assumes responsibility for this conversion.**
-

CONVERSION KIT SELECTION

Each conversion kit includes two or three spring kits and burner orifices for multiple unit sizes. Some parts will not be used—carefully select the parts to be used. Refer to [Table 1](#) for a list of natural gas to propane conversion kit components. Refer to [Table 2](#) for a list of propane to natural gas conversion kit components.

Table 1. Natural Gas to Propane Conversion Kit Components					
Unit Size	Model (Kit PN)	Component	Description	PN	Gas Valve (Manufacturer's PN)
All		Spring kit	#393691 for single-stage valve VR8105, VR8205, or VR8305	98720	—
		Tape	Conversion	64391	
		Disk	Propane	37752	
		Label*	High-elevation adjustment	197062	
030, 045	UDBP, UDBS (269840) or UBX, UBZ (1036541R)	Spring kit	#396221 for single-stage valve VR8215	260605	1/2-inch, single-stage (VR8105K2942, VR8205K2957, or VR8215T1239)
		Burner orifices	Refer to Table 3		
		Plate	Air restrictor, 1-3/16-inch (30 mm) diameter opening	203078	
	UDAP, UDAS (269835) or UDX, UDZ (1036536R)	Spring kit	#396221 for a VR8215 single-stage valve	260605	
		Burner orifices	Refer to Table 3		
		Plate	Air restrictor, 1-3/8-inch (35 mm) diameter opening	196687	
060, 075	UDBP, UDBS (269841) or UBX, UBZ (1036542R)	Spring kit	#396221 for single-stage valve VR8215	260605	1/2-inch, single-stage (VR8105K2942, VR8205K2957, or VR8215T1239) or 1/2-inch, two-stage (VR8105N2949 or VR8205N2921)
		Burner orifices	Refer to Table 3		
		Plate	Air restrictor restrictor, 1-9/16-inch (40 mm) diameter opening	202051	
	UDAP, UDAS (269836) or UDX, UDZ (1036537R)	Spring kit	#396221 for a VR8215 single-stage valve	260605	
		Burner orifices	Refer to Table 3		
		Plate	Air restrictor, 1-3/4-inch (44 mm) diameter opening	196688	
100, 125	UDAP, UDAS, UDBP, UDBS, (269837) or UBX, UBZ, UDX, UDZ (1036538R)	Spring kit	#396221 for single-stage valve VR8215	260605	1/2-inch, single-stage (VR8205K2957 or VR8215T1239) or 1/2-inch, two-stage (VR8205N2921)
		Burner orifices	Refer to Table 3		
		Plate**	Air restrictor, 1-3/4-inch (44 mm) diameter opening	196688	
150, 175	UDAP, UDAS, UDBP, UDBS, (269838) or UBX, UBZ, UDX, UDZ (1036539R)	Spring kit	#396221 for single-stage valve VR8215	260605	1/2-inch, two-stage (VR8205N2921)
		Burner orifices	Refer to Table 3		
		Plate**	Air restrictor, 1-3/4-inch (44 mm) diameter opening	196688	
200, 225, 250	UDAP, UDAS, UDBP, UDBS, (269839) or UBX, UBZ, UDX, UDZ (1036540R)	Spring kit	#396221 for single-stage valve VR8215	260605	1/2-inch, single-stage (VR8205K2957 or VR8215T1239), 3/4-inch single-stage (VR8305K4241), or 1/2-inch, two-stage (VR8205N2921 or VR8305N4297)
		Burner orifices	Refer to Table 3		
		Spring kit	#396021 for two-stage valve VR8105, VR8205, or VR8305	197207	
300, 350, 400	UDAP, UDAS, UDBP, UDBS, (201732) or UBX, UBZ, UDX, UDZ (1036543R)	Spring kit	#393691 for single-stage valve VR8305K	98720	3/4-inch, single-stage (VR8305K4241) or 3/4-inch, two-stage (VR8305N4297)
		Burner orifices	Refer to Table 3		

*Used only at installation elevations >2000 feet (>610 meters).

**The plate from kit PN 269837 is not used on unit size 125 models. The plate from kit PN 269838 is not used on unit size 175 models for residential or commercial applications.

CONVERSION KIT SELECTION—CONTINUED

Table 2. Propane to Natural Gas Conversion Kit Components					
Unit Size	Model (Kit PN)	Component	Description	PN	Gas Valve (Manufacturer's PN)
All		Spring kit	#394588 for single-stage valve VR8105, VR8205, or VR8305	98721	—
		Tape	Conversion	64391	
		Disk	Natural gas	1401	
		Label**	High-elevation adjustment	197062	
030, 045	UDAP, UDAS, UDBP, UDBS, (269851) or UBX, UBZ, UDX, UDZ (1036544R)	Spring kit	Spring kit #396222 for a VR8215 single-stage valve	261651	1/2-inch, single-stage (VR8105K2959, VR8205K2965, or VR8215T5214)
		Burner orifices	Refer to Table 3		
060, 075	UDAP, UDAS, UDBP, UDBS, (269853) or UBX, UBZ, UDX, UDZ (1036545R)	Spring kit	#396222 for single-stage valve VR8215	261651	1/2-inch, single-stage (VR85K2959, VR8205K2965, or VR8215T5214), or 1/2-inch, two-stage (VR8105N2931 or VR8205N2913)
			#396205 for two-stage valve VR8105, VR8205, or VR8305	197208	
Burner orifices	Refer to Table 3				
100, 125	UDAP, UDAS, UDBP, UDBS, (269853) or UBX, UBZ, UDX, UDZ (1036546R)	Spring kit	#396222 for single-stage valve VR8215	261651	
			#396205 for two-stage valve VR8105, VR8205, or VR8305	197208	
Burner orifices	Refer to Table 3				
150, 175	UDAP, UDAS, UDBP, UDBS, (269854) or UBX, UBZ, UDX, UDZ (1036547R)	Spring kit	#396222 for single-stage valve VR8215	261651	
			#396205 for two-stage valve VR8105, VR8205, or VR8305	197208	
Burner orifices	Refer to Table 3				
200, 225, 250	UDAP, UDAS, UDBP, UDBS, (269855) or UBX, UBZ, UDX, UDZ (1036548R)	Spring kit	#396222 for single-stage valve VR8215	261651	1/2-inch, single-stage (VR85K2959, VR8205K2965, or VR8215T5214),
			#396205 for two-stage valve VR8105, VR8205, or VR8305	197208	
		Burner orifices	Refer to Table 3		
300, 350, 400	UDAP, UDAS, UDBP, UDBS, (201738) or UBX, UBZ, UDX, UDZ (1036549R)	Spring kit	#396205 for two-stage valve VR8105, VR8205, or VR8305	197208	3/4-inch, single-stage (VR8305N4258) or 3/4-inch, two-stage (VR8305N4289)
		Burner orifices	Refer to Table 3		

*Used only at installation elevations >2000 feet (>610 meters).

INSTALLATION

Install the conversion kit in accordance with the following steps. Ensure that the kit is correct for the size of the heater being serviced (refer to [Table 1](#) or [Table 2](#)). Heater component locations are shown in [Figure 1](#).

1. Remove gas supply and electrical power:

- a. Turn off gas supply at shutoff valve outside of heater.
- b. Turn off electrical power.
- c. Open control access panel.

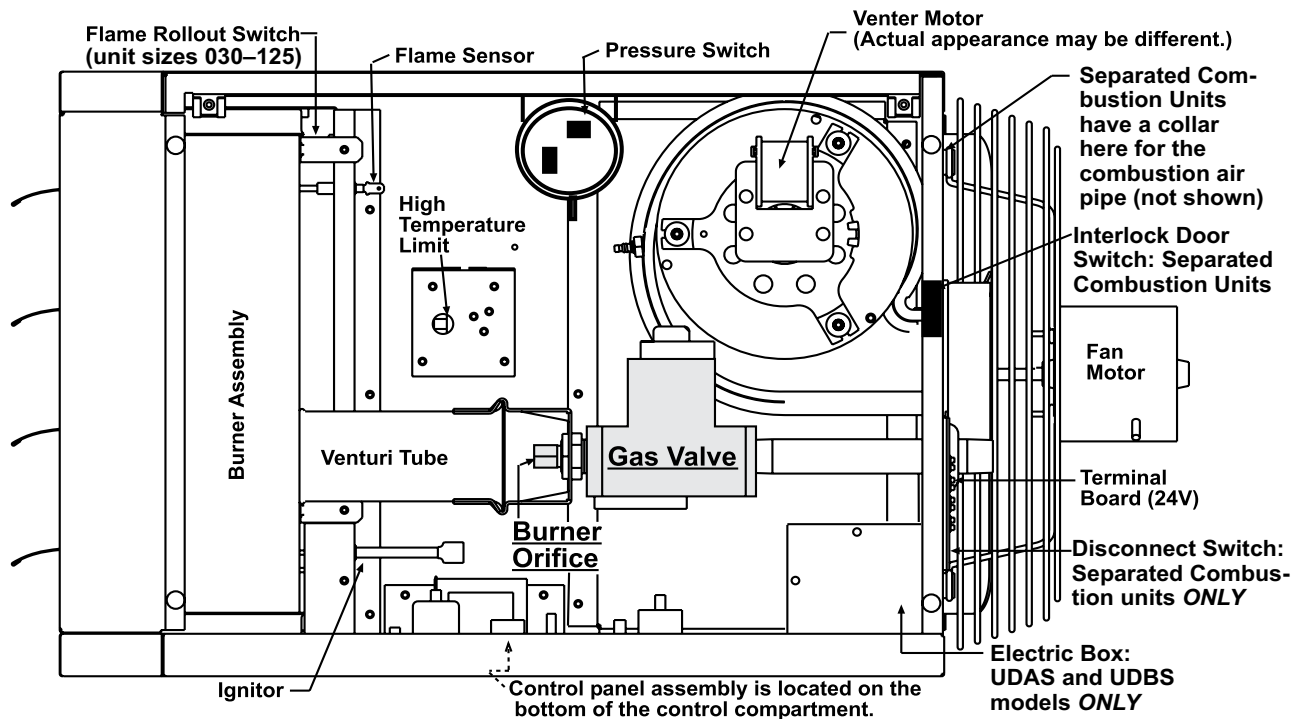

Figure 1. Heater Components

2. Install regulator spring kit:

⚠ WARNING ⚠

Regulator spring kits are not interchangeable. Each kit must be used only in the model and type of gas valve for which the kit is designated. Verify compatibility before installing the regulator spring kit.

- a. Select regulator spring kit that corresponds with gas valve on heater. All gas conversion kits include one or two regulator spring kits for single-stage valve and one regulator spring for two-stage valve. Other included regulator spring kits will not be used.
- b. Install regulator spring kit in accordance with gas valve manufacturer's instructions (included with regulator spring kit).

NOTE: After a new regulator spring kit is installed, it is necessary to adjust the spring for correct manifold pressure. This adjustment can be made only after the heater is in operation (refer to step 7).

3. Remove or install air restrictor plate as necessary and replace burner orifice:

- a. Carefully remove existing burner orifice (see Figure 2, DETAIL A).

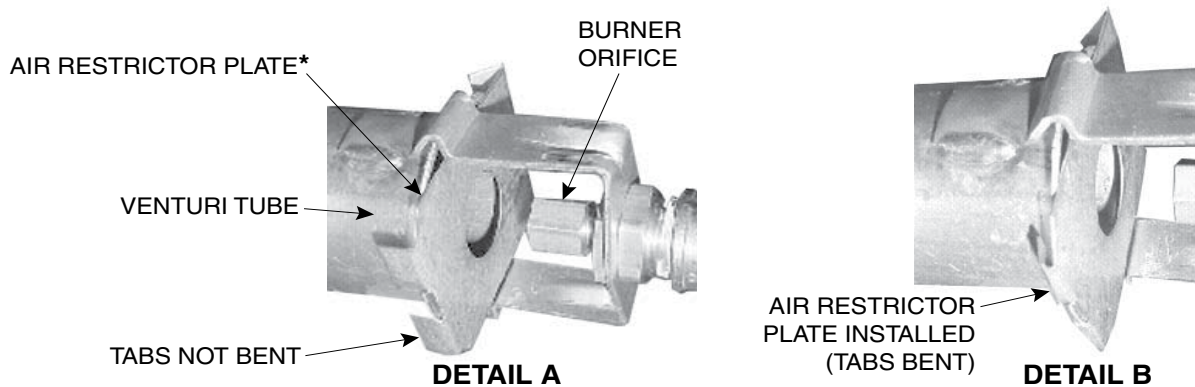

*USED ONLY ON UNIT SIZES 030, 045, 060, 075, 100, AND 150 (ALL PROPANE MODELS) AND UNIT SIZE 125 (PROPANE MODELS UDBP, UDBS, UBX, AND UBZ).

Figure 2. Burner Orifice and Air Restrictor Plate

INSTALLATION—CONTINUED



- The air restrictor plate **MUST BE INSTALLED** when converting unit sizes 030, 045, 060, 075, 100, and 150 (all models) and unit size 125 (models UDBP, UDBS, UBX, and UBZ) to propane.
- The air restrictor plate **MUST BE REMOVED** when converting unit sizes 030, 045, 060, 075, 100, and 150 (all models) and unit size 125 (models UDBP, UDBS, UBX, and UBZ) to natural gas.
- For these models/unit sizes, the failure to install or remove the air restrictor plate in accordance with the following directions can cause death or injury and/or property damage.

- b. For unit sizes 030, 045, 060, 075, 100, and 150 (all models) and unit size 125 (models UDBP, UDBS, UBX, and UBZ), proceed to step c. For all other models/unit sizes, proceed to step e.
- c. If converting from propane to natural gas, remove air restrictor plate as follows. If converting from natural gas to propane, install air restrictor plate in accordance with step d.
 - (1) See [Figure 2](#), DETAIL B to locate air restrictor plate held in place on venturi tube by its bent tabs.
 - (2) Use pliers to carefully unbend tabs as shown in [Figure 2](#), DETAIL A and remove air restrictor plate.
- d. For natural gas to propane conversion, install air restrictor plate as follows:
 - (1) Refer to [Table 1](#) or [Table 2](#) to select correct air restrictor plate. Slide plate in place over venturi tube opening so that its 45-degree angle is hooked over rear of venturi tube (see [Figure 2](#)).
 - (2) While holding plate in position, use pliers to carefully bend tabs to lock plate in place (see [Figure 2](#), DETAIL B). Ensure that air restrictor is aligned and secure.
- e. For all conversions, select replacement burner orifices in accordance with [Table 3](#). All conversion kits include two or three burner orifices. Other included orifice(s) will not be used.

Table 3. Burner Orifices

Unit Size	Model	Natural Gas	Propane
		Orifice Size/Marking (PN)	
030	UDAP, UDAS, UDBP, UDBS	#37 (196853)	1.6 mm (196844)
	UBX, UBZ, UDX, UDZ	#39 (196852)	
045	UDAP, UDAS, UDBP, UDBS	#30 (196838)	#48 (196845)
	UBX, UBZ, UDX, UDZ	3.1 mm (120144)	
060	UDAP, UDAS, UDBP, UDBS	3.7 mm (196839)	2.3 mm (196846)
	UBX, UBZ, UDX, UDZ	#28 (124969)	2.25 mm (1034350)
075	UDAP, UDAS, UDBP, UDBS	#19 (196855)	#39 (196852)
	UBX, UBZ, UDX, UDZ	#22 (196361)	#40 (120137)
100	UDAP, UDAS, UDBP, UDBS	#10 (120158)	3.0 mm (196854)
	UBX, UBZ, UDX, UDZ	#14 (208247)	#32 (120141)
125	UDAP, UDAS, UDBP, UDBS	#4 (196840)	3.2 mm (196847)
	UBX, UBZ, UDX, UDZ	#10 (120158)	3.1 mm (120144)
150	UDAP, UDAS, UDBP, UDBS	5.9 mm (131581)	9/64-inch (196898)
	UBX, UBZ, UDX, UDZ	5.6 mm (208243)	3.5 mm (120148)
175	UDAP, UDAS, UDBP, UDBS	E (196891)	#24 (196899)
	UBX, UBZ, UDX, UDZ	6.0 mm (208245)	#27 (120149)
200	UDAP, UDAS, UDBP, UDBS	6.8 mm (196892)	4.1 mm (196900)
	UBX, UBZ, UDX, UDZ	F (120167)	
225	All	6.95 mm (221121)	11/64 inch (196901)
250	UDAP, UDAS, UDBP, UDBS	L (208255)	#14 (196902)
	UBX, UBZ, UDX, UDZ		4.60 mm (1034352)
300	UDAP, UDAS, UDBP, UDBS	8.0 mm (221122)	#8 (196903)
	UBX, UBZ, UDX, UDZ	7.8 mm (208253)	
350	UDAP, UDAS, UDBP, UDBS	8.7 mm (221123)	#3 (196904)
	UBX, UBZ, UDX, UDZ	8.5 mm (1034354)	5.4 mm (1034353)
400	UDAP, UDAS, UDBP, UDBS	9.6 mm (196897)	5.8 mm (196905)
	UBX, UBZ, UDX, UDZ	9.2 mm (1034355)	

⚠ WARNING ⚠

Do not attempt to drill burner orifice. Use factory-supplied orifice only.

- f. Install replacement burner orifice (see [Figure 2](#), DETAIL A).
-

⚠ CAUTION ⚠

If the heater will be operated at an elevation >6,000 feet (>1,830 meters), a high-elevation pressure switch must be installed.

NOTES:

- **If the installation elevation is >6,000 feet (>1,830 meters), verify that the elevation on the rating plate or high-elevation label is >6,000 feet (>1,830 meters). If the rating plate or label does not indicate an elevation of >6,000 feet (>1,830 meters), order and install the appropriate high pressure switch kit.**
 - **If the heater is equipped for installation at an elevation of >6,000 feet (>1,830 meters) and is being installed at a lower elevation, order and install the appropriate switch.**
 - **Contact your distributor to select the factory-authorized replacement part.**
-

4. For installations at elevations >6,000 feet (>1,830 meters), replace pressure switch:

- a. Locate pressure switch in control compartment (see [Figure 1](#)) and mark and disconnect two pressure switch wires.
- b. Mark and disconnect sensing tube(s) from pressure switch.
- c. Remove two screws that secure mounting bracket and remove bracket and pressure switch. Save bracket and screws for reuse.
- d. Install replacement pressure switch using mounting bracket and two screws. Reconnect sensing tube(s) and wires.

5. Restore electrical power and gas supply:

- a. Turn on electrical power.
- b. Turn on gas supply and relight heater, following instructions on heater.

6. Perform leak test:

- a. Check all connections for gas leaks using commercial leak-detecting fluid or rich soap and water solution. Leaks are indicated by presence of bubbles.
- b. If leak is detected, tighten connection. If leak cannot be stopped by tightening connection, replace part(s).

7. Adjust manifold (outlet) pressure:

⚠ WARNING ⚠

Manifold gas pressure must never exceed 3.5 IN WC for natural gas or 10 IN WC for propane.

- a. Determine correct outlet pressure (refer to [Table 4](#)) for elevation of installation. If unsure of elevation, contact local gas supplier.
 - b. Turn knob or switch on top of valve to OFF to prevent flow to gas valve.
-

NOTE: A manometer (fluid-filled gauge) is recommended rather than a spring-type gauge due to the difficulty of maintaining the calibration of a spring-type gauge. Use a water column manometer that is readable to the nearest tenth of an inch.

- c. Connect manometer to 1/8-inch output pressure tap on valve (see [Figure 3](#)).

INSTALLATION—CONTINUED

Table 4. Required Manifold (Outlet) Gas Pressure					
Elevation		Single-Stage and Two-Stage High-Fire		Two-Stage Low-Fire	
Feet	Meters	Natural Gas	Propane	Natural Gas	Propane
Manifold Pressure (IN WC)					
US					
0–2000	0–610	3.5	10.0	1.8	5.0
2001–3000	611–915	3.1	8.8	1.6	4.4
3001–4000	916–1220	3.0	8.5	1.5	4.2
4001–5000	1221–1525	2.8	8.1	1.5	4.1
5001–6000	1526–1830	2.7	7.7	1.4	3.9
6001–7000	1831–2135	2.6	7.4	1.3	3.7
7001–8000	2136–2440	2.5	7.1	1.3	3.5
8001–9000	2441–2745	2.4	6.7	1.2	3.4
9001–10,000	2746–3045	2.3			
Canada					
0–2000	0–610	3.5	10.0	1.8	5.0
2001–4500	611–1373	2.8	8.1	1.5	4.1

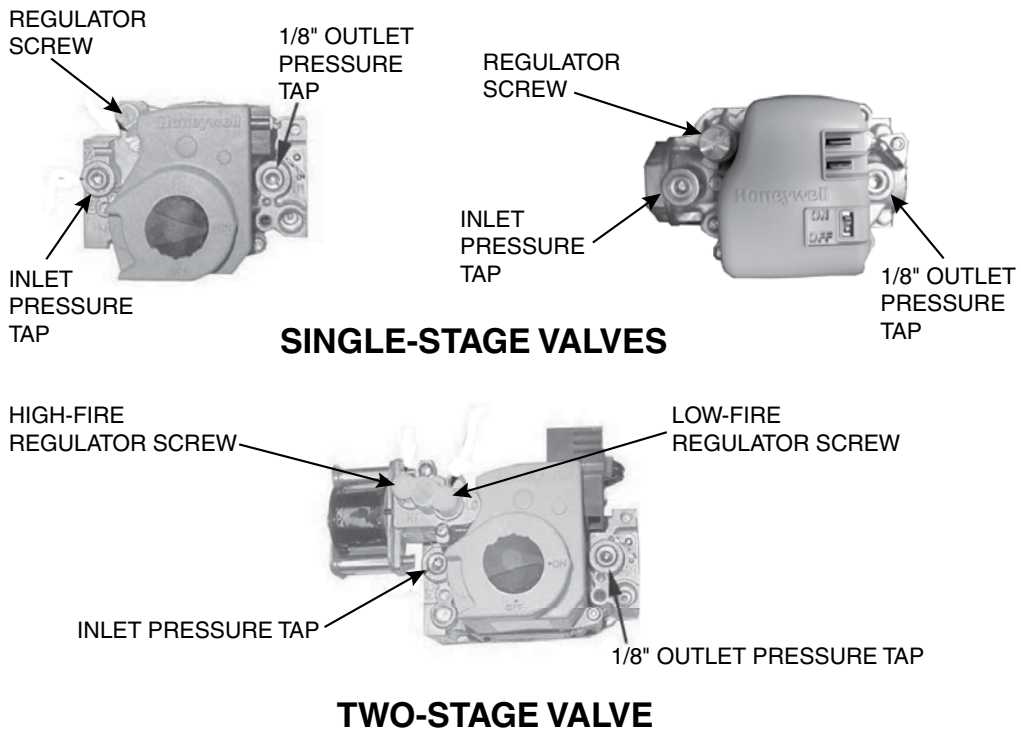

Figure 3. Gas Valves

⚠ CAUTION ⚠

DO NOT bottom out the gas valve regulator screw. This can result in excessive overfire and heat exchanger failure due to unregulated manifold pressure.

- d. For single-stage or two-stage high fire valve:
 - (1) Turn knob or switch on top of valve to ON.
 - (2) Remove cap from regulator screw (see [Figure 3](#)) and adjust pressure in accordance with [Table 4](#) by turning regulator screw IN (clockwise) to increase pressure or OUT (counterclockwise) to decrease pressure.
- e. For two-stage low fire valve:
 - (1) Disconnect wire from HI terminal on gas valve.
 - (2) Remove cap from low-fire regulator screw (see [Figure 3](#)) and adjust pressure in accordance with [Table 4](#) by turning regulator screw IN (clockwise) to increase pressure or OUT (counterclockwise) to decrease pressure.
 - (3) Reconnect wire to Hi terminal on gas valve.
- f. Turn up thermostat. For models UDAS, UDBS, UBZ, and UDZ, depress and hold door safety switch.
- g. Cycle burner once or twice to properly seat adjustment spring in valve and recheck outlet pressure. When pressure corresponds to [Table 4](#), disconnect manometer and install cap on regulator screw.
- h. Check for leakage at 1/8-inch outlet pressure tap fitting. Correct as necessary.
- i. Connect manometer to inlet pressure tap (see [Figure 3](#)). While heater is operating, measure inlet pressure, which should be as follows:
 - (1) between 5 and 13.5 IN WC for all natural gas models
 - (2) between 10 and 13.5 IN WC for UDAP, UDAS, UDBP, and UDBS propane models
 - (3) between 11 and 13.5 IN WC for UBX, UBZ, UDX, and UDZ propane models
- j. If inlet pressure is not in accordance with step 7i, it must be corrected by adjusting manifold (outlet) pressure in accordance with steps 7b through 7e.

NOTES:

- **Conversion of a unit using these kits does not alter the input rate. Refer to the rating plate on the heater for the input rate and other appropriate information.**
 - **If adjusted for high-elevation operation, the input rate will be affected.**
 - **The high-elevation adjustment label is not used on units operated at elevations of $\leq 2,000$ feet (≤ 610 meters).**
-

- k. Refer to [APPENDIX](#) for input and capacity values for elevation of installation.
 - (1) Use permanent marker to fill in appropriate input and capacity values on high-elevation adjustment label from literature bag provided with unit.
 - (2) Select location for label on outside of heater access panel that will be conspicuous to anyone operating or servicing unit.
 - (3) Ensure that surface is clean and dry and affix label.
- l. Observe heater operation for at least one complete cycle to check for safe and proper operation. For models UDAS, UDBS, UBZ, and UDZ, depress and hold safety door switch.

8. Close control access panel.

APPENDIX: INPUTS AND CAPACITIES BY ELEVATION

Inputs and Capacities by Elevation in US															
Elevation (Feet (Meters))	Value*	Unit Size													
		030	045	060	075	100	125	150	175	200	225	250	300	350	400
		BTUh													
0–2000 (0–610)	A	30,000	45,000	60,000	75,000	105,000	120,000	150,000	175,000	200,000	225,000	250,000	300,000	350,000	400,000
	B	24,600	37,350	49,800	62,250	88,200	100,800	124,500	145,250	166,000	186,750	207,500	249,000	290,500	332,000
	C	30,000	45,000	42,000	52,500	73,500	84,000	105,000	122,500	140,000	157,500	175,000	210,000	245,000	280,000
2001–3000 (611–915)	A	28,200	42,300	56,400	70,500	98,700	112,800	141,000	164,500	188,000	211,500	235,000	282,000	329,000	376,000
	B	23,124	35,109	46,812	58,515	82,908	94,752	117,030	136,535	156,040	175,545	195,050	234,060	273,070	312,080
	C	28,200	42,300	39,480	49,350	69,090	78,960	98,700	115,150	131,600	148,050	164,500	197,400	230,300	263,200
3001–4000 (916–1220)	A	27,600	41,400	55,200	69,000	96,600	110,400	138,000	161,000	184,000	207,000	230,000	276,000	322,000	368,000
	B	22,632	34,362	45,816	57,270	81,144	92,736	114,540	133,630	152,720	171,810	190,900	229,080	267,260	305,440
	C	27,600	41,400	38,640	48,300	67,620	77,280	96,600	112,700	128,800	144,900	161,000	193,200	225,400	257,600
4001–5000 (1221–1525)	A	27,000	40,500	54,000	67,500	94,500	108,000	135,000	157,500	180,000	202,500	225,000	270,000	315,000	360,000
	B	22,140	33,615	44,820	56,025	79,380	90,720	112,050	130,725	149,400	168,075	186,750	224,100	261,450	298,800
	C	27,000	40,500	37,800	47,250	66,150	75,600	94,500	110,250	126,000	141,750	157,500	189,000	220,500	252,000
5001–6000 (1526–1830)	A	26,400	39,600	52,800	66,000	92,400	105,600	132,000	154,000	176,000	198,000	220,000	264,000	308,000	352,000
	B	21,648	32,868	43,824	54,780	77,616	88,704	109,560	127,820	146,080	164,340	182,600	219,120	255,640	292,160
	C	26,400	39,600	36,960	46,200	64,680	73,920	92,400	107,800	123,200	138,600	154,000	184,800	215,600	246,400
6001–7000 (1831–2135)	A	25,800	38,700	51,600	64,500	90,300	103,200	129,000	150,500	172,000	193,500	215,000	258,000	301,000	344,000
	B	21,156	32,121	42,828	53,535	75,852	86,688	107,070	124,915	142,760	160,605	178,450	214,140	249,830	285,520
	C	25,800	38,700	36,120	45,150	63,210	72,240	90,300	105,350	120,400	135,450	150,500	180,600	210,700	240,800
7001–8000 (2136–2440)	A	25,200	37,800	50,400	63,000	88,200	100,800	126,000	147,000	168,000	189,000	210,000	252,000	294,000	336,000
	B	20,664	31,374	41,832	52,290	74,088	84,672	104,580	122,010	139,440	156,870	174,300	209,160	244,020	278,880
	C	25,200	37,800	35,280	44,100	61,740	70,560	88,200	102,900	117,600	132,300	147,000	176,400	205,800	235,200
8001–9000 (2441–2745)	A	24,600	36,900	49,200	61,500	86,100	98,400	123,000	143,500	164,000	184,500	205,000	246,000	287,000	328,000
	B	20,172	30,627	40,836	51,045	72,324	82,656	102,090	119,105	136,120	153,135	170,150	204,180	238,210	272,240
	C	24,600	36,900	34,440	43,050	60,270	68,880	86,100	100,450	114,800	129,150	143,500	172,200	200,900	229,600
9001–10,000 (2746–3045)	A	24,000	36,000	48,000	60,000	84,000	96,000	120,000	140,000	160,000	180,000	200,000	240,000	280,000	320,000
	B	19,680	29,880	39,840	49,800	70,560	80,640	99,600	116,200	132,800	149,400	166,000	199,200	232,400	265,600
	C	24,000	36,000	33,600	42,000	58,800	67,200	84,000	98,000	112,000	126,000	140,000	168,000	196,000	224,000

*A = normal input, B = thermal output capacity, and C = minimum input.

Inputs and Capacities by Elevation in Canada															
Elevation (Feet (Meters))	Value*	Unit Size													
		030	045	060	075	100	125	150	175	200	225	250	300	350	400
		BTUh													
0–2000 (0–610)	A	30,000	45,000	60,000	75,000	105,000	120,000	150,000	175,000	200,000	225,000	250,000	300,000	350,000	400,000
	B	24,600	37,350	49,800	62,250	88,200	100,800	124,500	145,250	166,000	186,750	207,500	249,000	290,500	332,000
	C	30,000	45,000	42,000	52,500	73,500	84,000	105,000	122,500	140,000	157,500	175,000	210,000	245,000	280,000
2001–4500 (611–1373)	A	27,000	40,500	54,000	67,500	94,500	108,000	135,000	157,500	180,000	202,500	225,000	270,000	315,000	360,000
	B	22,140	33,615	44,820	56,025	79,380	90,720	112,050	130,725	149,400	168,075	186,750	224,100	261,450	298,800
	C	27,000	40,500	37,800	47,250	66,150	75,600	94,500	110,250	126,000	141,750	157,500	189,000	220,500	252,000

*A = normal input , B = thermal output capacity, and C = minimum input.

NOTES



Specifications and illustrations subject to change without notice or incurring obligations.
©2021 Nortek Global HVAC LLC, O'Fallon, MO.
All rights reserved.
CP-UB-UD-GC (04-21) 1034364-A

