

MASTERTM 14x

Belt Scale Weigh Frame

Installation Manual



© Rice Lake Weighing Systems. All rights reserved.

Rice Lake Weighing Systems® is a registered trademark of
Rice Lake Weighing Systems.

All other brand or product names within this publication are trademarks or
registered trademarks of their respective companies.

All information contained within this publication is, to the best of our knowledge, complete and
accurate at the time of publication. Rice Lake Weighing Systems reserves the right to make
changes to the technology, features, specifications and design of the equipment without notice.

The most current version of this publication, software, firmware and all other product
updates can be found on our website:

www.ricelake.com

Revision History

This section tracks and describes manual revisions for awareness of major updates.

Revision	Date	Description
A	May 19, 2020	Initial release
B	June 23, 2025	Updated Selection Criteria and format; added disposal information
C	September 25, 2025	Updated Mechanical Installation section

Table i. Revision Letter History



Technical training seminars are available through Rice Lake Weighing Systems. Course descriptions and dates can be viewed at www.ricelake.com/training or obtained by calling 715-234-9171 and asking for the training department.

Contents

1.0 Introduction	5
1.1 Safety	5
1.2 Disposal	6
1.3 Overview	6
1.4 Selection Criteria	7
1.5 Calibration and Test Weight Device	7
2.0 Installation	8
2.1 Mechanical Installation	9
2.2 Electrical Installation	12
2.3 Commissioning	12
3.0 Maintenance	13
3.1 Maintenance	13
3.2 Dimensional Drawings	13
3.3 List Parameters for Belt Scale	15
4.0 Appendix	16
4.1 Specifications	16
4.2 Total Load Cell Build Conversion	16



Rice Lake continually offers web-based video training on a growing selection of product-related topics at no cost. Visit www.ricelake.com/webinars

1.0 Introduction

Belt scales measure a continuous mass flow, which is transported over a belt conveyor. A complete belt scale is composed of a weigh frame, which contains one or more load cells, a speed sensor/pickup and the integrator electronics.

Not every application is suited for a belt scale; this has to be analyzed by a Rice Lake Weighing Systems specialist. To achieve the optimum result, the Master™ Belt Scale series has been developed for a number of applications and for every type of conveyor.



Manuals are available from Rice Lake Weighing Systems at www.ricelake.com/manuals

Warranty information is available at www.ricelake.com/warranties

1.1 Safety

Safety Definitions:



DANGER: Indicates an imminently hazardous situation that, if not avoided, will result in death or serious injury. Includes hazards that are exposed when guards are removed.



WARNING: Indicates a potentially hazardous situation that, if not avoided, could result in serious injury or death. Includes hazards that are exposed when guards are removed.



CAUTION: Indicates a potentially hazardous situation that, if not avoided, could result in minor or moderate injury.



IMPORTANT: Indicates information about procedures that, if not observed, could result in damage to equipment or corruption to and loss of data.

General Safety

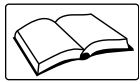

Do not operate or work on this equipment unless this manual has been read and all instructions are understood. Failure to follow the instructions or heed the warnings could result in injury or death. Contact any Rice Lake Weighing Systems dealer for replacement manuals.



WARNING

Failure to heed could result in serious injury or death.

Some procedures described in this manual require work inside the enclosure. These procedures are to be performed by qualified service personnel only.

Take all necessary safety precautions when installing the scale carriage including wearing safety shoes, protective eye wear, and using the proper tools.

Keep hands, feet and loose clothing away from moving parts.

Do not approach a running conveyor from underneath.

Do not bend over a running conveyor.

Do not allow minors (children) or inexperienced persons to operate this unit.

Do not operate without all shields and guards in place.

Do not jump on the scale.

Do not use for purposes other than weight taking.

Do not place fingers into slots or possible pinch points.

Do not use any load bearing component that is worn beyond 5% of the original dimension.

Do not use this product if any of the components are cracked.

Do not exceed the rated load limit of the unit.

Do not make alterations or modifications to the unit.

Do not remove or obscure warning labels.

Do not use near water.

1.2 Disposal



Product Disposal

The product must be brought to appropriate separate waste collection centers at the end of its life cycle.

Proper separate collection to recycle the product helps prevent possible negative effects on the environment and to health, and promotes the recycling of the materials. Users who dispose of the product illegally shall face administrative sanctions as provided by law.

1.3 Overview

The 14x Master Belt Scale Weigh Frame is designed for heavy duty applications in the process industry, where accuracy is required and the 14x Master Belt Scale Weigh Frame may be designed using two, three or four idlers depending on the application.

The dimensions are extracted from the construction of the existing, or to-be built, belt conveyor.

1.3.1 Theory of Operation

The material is carried by the belt and underlying rollers or idler stations. One or more of these idlers are mounted on the weigh frame and are used to weigh the material going across the belt. The material carried on the belt is weighed and the belt speed is measured. Both values (belt load and belt speed) are calculated in an integration function. The integrator totals and calculates the mass flow. These values are displayed and transmitted through outputs or other forms of communication to a control system or network.

For the operation, refer to the manual of the electronics installed.

1.4 Selection Criteria

Load cell capacity is calculated based on the maximum belt load plus the dead load of the weigh frame and the weight of the rollers.

Weighing length = $\frac{1}{2} \times$ (1st unweighed idler distance + last unweighed idler distance) + all weighed idler distances

Net load = (conveyor capacity / belt speed) x weighing length

Gross load = net load + (idler weights + belt weight + mounting hardware)

Example (Imperial):

Weighing length = $\frac{1}{2} \times$ (48 in. + 48 in.) + 48 in. + 48 in.

Weighing length = 48 in. + 48 in. + 48 in.

Weighing length = 144 in.

Weighing length = 12 feet

Net load = (50,000 lbs per hour / 400 feet per minute belt speed) x 12 foot weighing length

Net load = (125 lb per foot) x 12 foot weighing length

Net load = 1500 lb

Gross load = 1500 lb + (175 lb idler + 175 lb idler + 125 lb belt + 400 lb hardware)

Gross load = 2375 lb



NOTE: The 14x uses (4) RL20000 S-beam load cells so the total load cell build used should be approximately equal to or greater than double the Gross Load. In this example, 1500 lb load cells should be used.

Examples (Metric):

Weighing length = $\frac{1}{2} \times$ (1 m + 1 m) + 1 m + 1 m

Weighing length = 1 m + 1 m + 1 m

Weighing length = 3 m

Net load = (24,000 kg per minute / 120 meters per minute) x 3 meter weighing length

Net load = (200 kg per meter) x 3 meter weighing length

Net load = 600 kg

Gross load = 425 kg + (90 kg idler 90 kg idler + 45 kg belt + 200 kg hardware)

Gross load = 1025 kg



NOTE: The 14x uses (4) RL20000 S-beam load cells so the total loadcell build used should be approximately equal or greater than double the Gross Load. In this example 500 kg load cells should be used.

1.5 Calibration and Test Weight Device

Mounting points can be provided to apply static test weights. Test weights are used to test repeatability and the state of the belt scale after initial calibration. Consult with factory for the amount of static test weight for your application.

To determine absolute accuracy, it is necessary to do a test with material. For this procedure, refer to the manual of the electronics installed.

2.0 Installation

Installation procedures generally should be a combination of the end user's best engineering practices in compliance with local codes and the manufacturer's recommendations. To achieve maximum performance, the following precautions should be observed.



DANGER: Take all necessary safety precautions when installing the scale carriage including wearing safety shoes, protective eye wear and using the proper tools.

Always turn off the power supply before any connection is made or removed.

Before welding, the power supply must be off and the connectors removed.

The load cell is very sensitive to damage by welding. The welding ground clamp must be attached to the same side of the weigh frame where welding. When in doubt, remove the load cell(s).



IMPORTANT: Follow the recommendations given when the application was checked.

Belt conveyor must be installed in a stable and rigid area, free from vibrations.

The construction of the belt frame must be stiff enough to prevent torsion or bending at the maximum load (including the weigh frame).

The weigh frame must be mounted free of mechanical tensions.

No vibrations in the conveyor should be allowed to carry over to the weigh frame. If needed, these must be filtered.

The belt must be of good quality and a single splice. A vulcanized splice will provide the best accuracy. The weight per foot (meter) should be consistent over the whole length.

The belt must not track out of the center and no steering idler must be placed near the weighing area.

The belt support must not be provided with two part (v-shape) idler stations.

At least three idler stations before and three idler stations after the weigh frame have to be adjustable in height. For short belt conveyors this can be reduced to one roller before and one roller after the weigh frame.

String alignment should be used on all idlers in the scale system. If following the rule of three before and three after, seven idlers (including the weigh idler) should be checked during the alignment process.

Rollers should not have a concentricity exceeding +/- 0.012 in (0.3 mm).

The speed sensor should be mounted on a non-driven roller or drum.

The inclination angle of the belt conveyor must not exceed 25°.

Proper covers may be required to prevent air flow from interfering with the belt scale.

Side guards and belt skirting should not be in contact with the weighing area of the belt scale.

2.1 Mechanical Installation

The mechanical installation of a belt scale consists of mounting the weigh frame, the speed pickup and a junction box.

 **NOTE:** Belt has been removed for illustration purposes only.

1. Determine the location for the weighing idler. This location should be at least five idlers after the load point of the conveyor and at least five idlers before the head pulley.
2. Measure the center-to-center distance of the idlers. Note this for placement of the weigh frame and idlers.

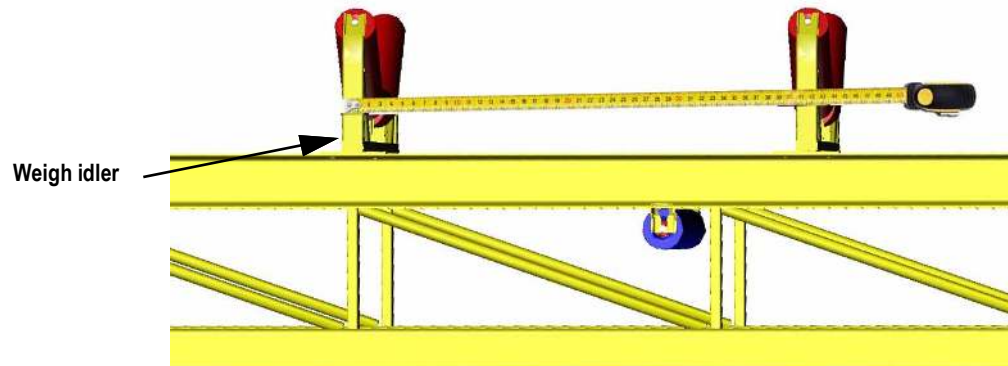

Figure 2-1. Measure Center-to-Center Distance of the Idlers

3. Remove the existing idler where weigh frame is to be located.

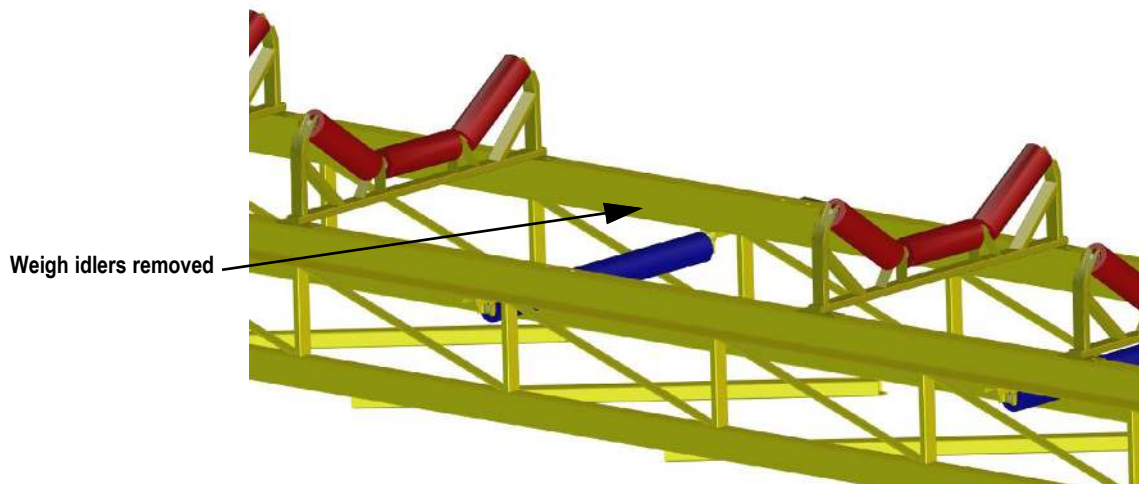

Figure 2-2. Remove Necessary Stationary Idlers for Weigh Frame Installation

 **IMPORTANT:** See print for exact clearances.

4. Install weigh frame to conveyor.

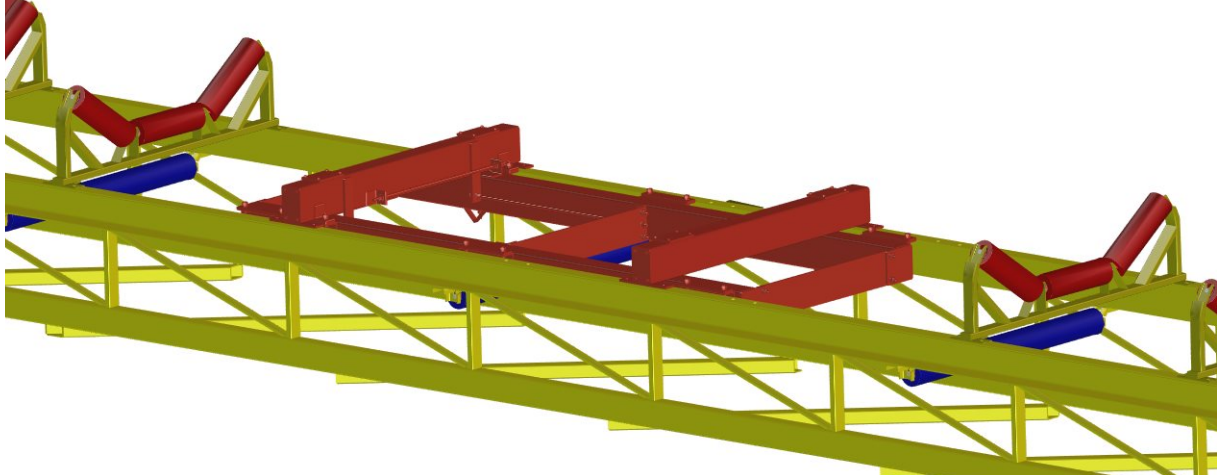

Figure 2-3. Add Weigh Frame Assembly to Conveyor

5. Remove shipping block from load bridge assembly.

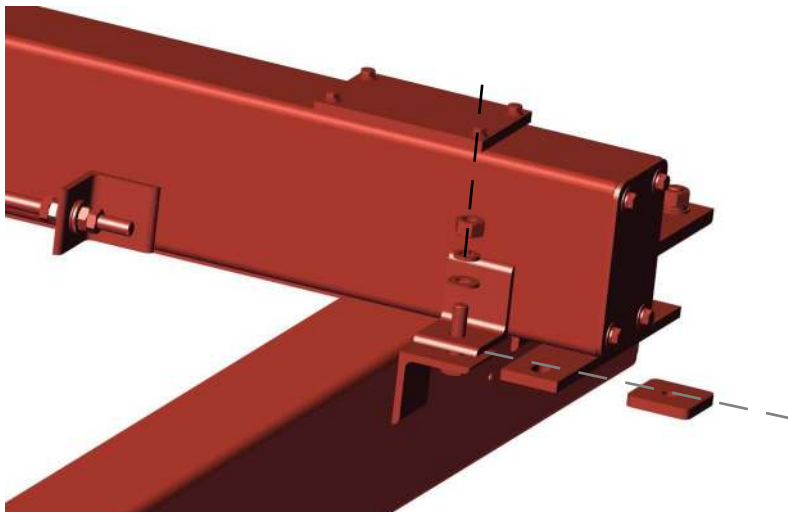

Figure 2-4. Remove Shipping Tab

6. Modify the idler station by removing the mounting feet from each end of the idler frame using a cutting torch or grinder.

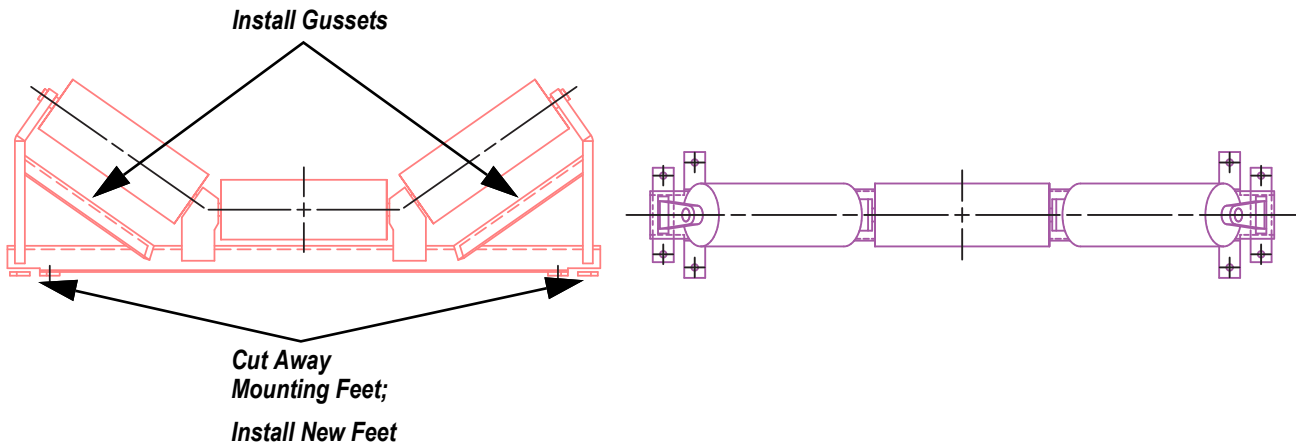

Figure 2-5. Idler Station Modification



NOTE: For illustration purposes only. Required modifications may vary.

7. Drill out hole locations to accommodate bridge mounting bolts, secure weldment with four 1/2 inch bolts (not provided with 14x). Ensure they do not interfere with any idlers or live sections of the weigh frame.

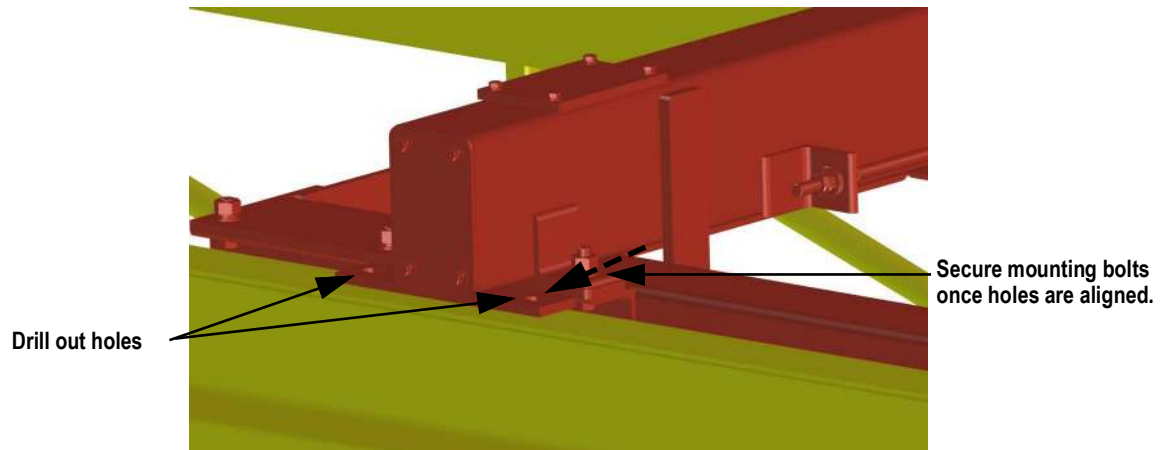

Figure 2-6. Use Bolts to Position Weldment

8. Run strings on the conveyor (three before the scale and three past the scale) and shim the idlers to the same plane.

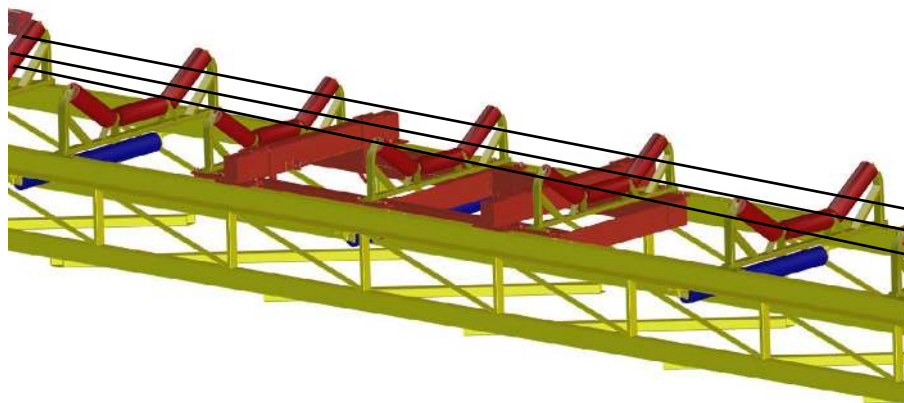

Figure 2-7. Run Strings to Same Plane

9. Mount junction box in appropriate location.
10. Wire load cells according to the load cell data sheets and junction box manual.
11. Terminate home run cable at the junction box Adjust overload stops, see [Section 4.2 on page 16](#).
12. Calibrate the 14x using the calibration procedure for the applicable integrator.

2.2 Electrical Installation

The wiring and connections between the weigh frame, speed pickup and the electronics are shown in the applicable scheme. See [Section 4.2 on page 16](#).

The load cell is provided with a fixed cable; do not alter the length. If necessary, use an additional junction box with screw terminals to extend the cable length.

2.2.1 Cable Types

Load cell

If the length is more than 197 feet (60 meters), use shielded 6 wire cable 20 AWG gauge (0.5 mm²).

Speed pickup

Use shielded 3 wire cable 20 AWG gauge (0.5 mm²).

Shielding

Cable shielding must be connected to one side only. If connected to the instrument side, then it is preferred to use the same ground as the power supply.

2.3 Commissioning

Commissioning should be performed by service engineers who are trained and experienced with the subject.

2.3.1 Mechanical Adjustments

Mechanical adjustments must be made to ensure the scale is free of any tension. If necessary, the load cell can be adjusted.

3.0 Maintenance

Regular maintenance is essential to prevent errors or unnecessary down time. The supplier does not accept any responsibility for the consequences of not performing the maintenance recommended in this section.

3.1 Maintenance



WARNING: It is important to guarantee the safety of personnel during maintenance work and to assure no accidents will happen. Before any work on electrical systems is started, be sure to remove the main power supply.

The conveyor must be shut off before any work on the conveyor is started. Any goods on the conveyor must be removed first. No unauthorized persons are allowed in the conveyor's working area.

3.1.1 Periodical Maintenance

To keep the belt scale in optimal condition, it is important to perform periodical maintenance.

- Ensure there is not a build up of debris on the belt
- Inspect the weigh frame for damaged areas and repair as necessary
- Regularly perform an Auto Zero and a weight check with certified test weights to determine if the belt scale weighs correctly. For this procedure, refer to the manual of the electronics installed

3.2 Dimensional Drawings

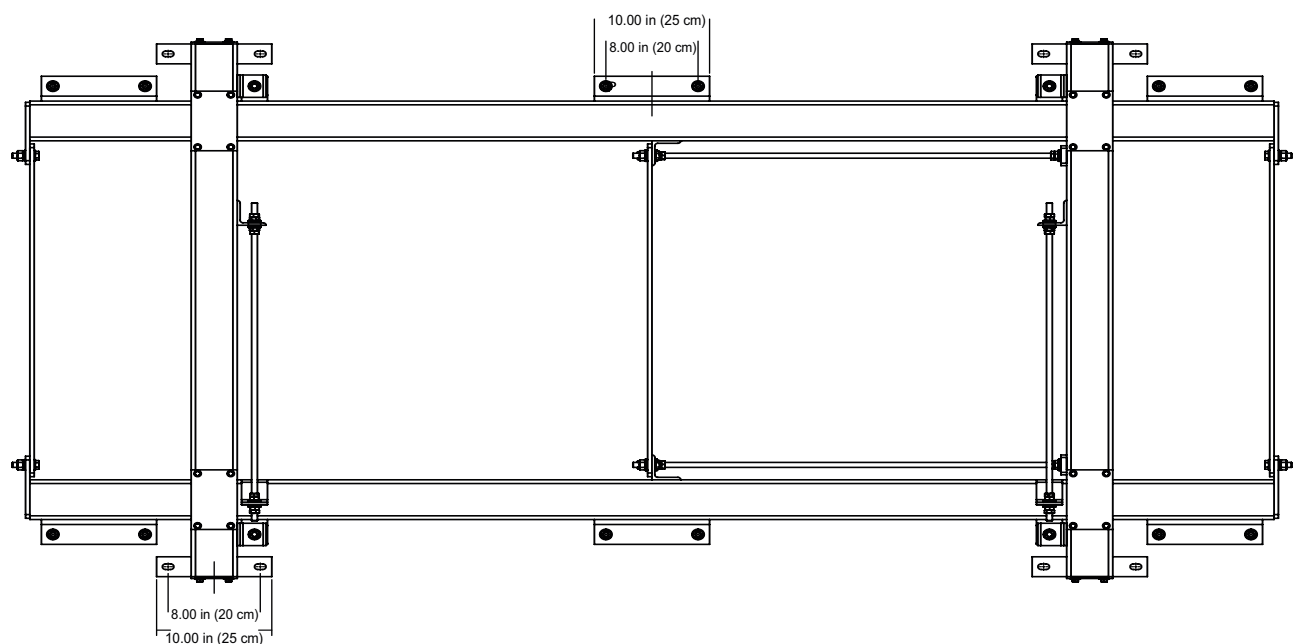

Figure 3-1. 14x Dimensions

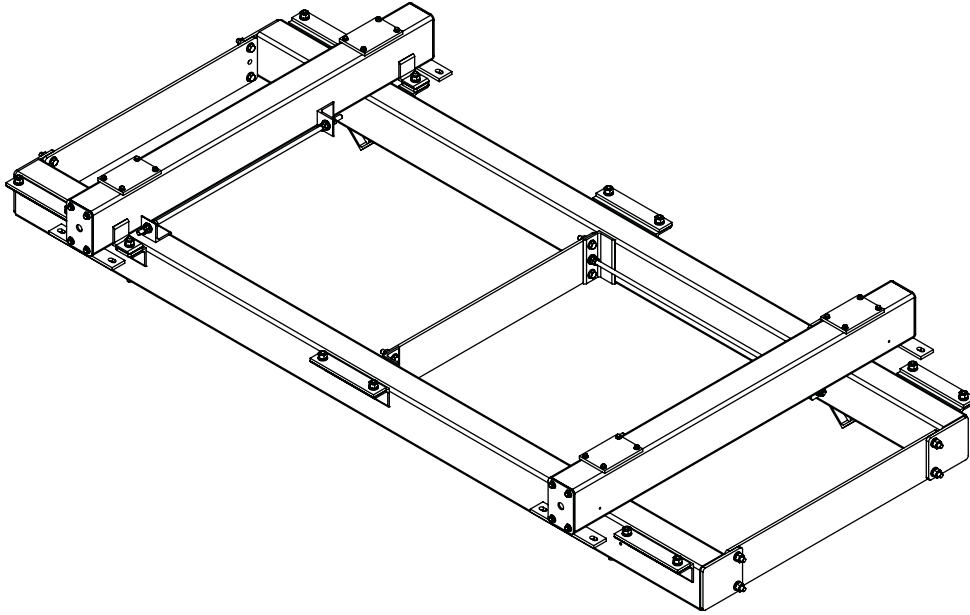

Figure 3-2. 14x Assembly View

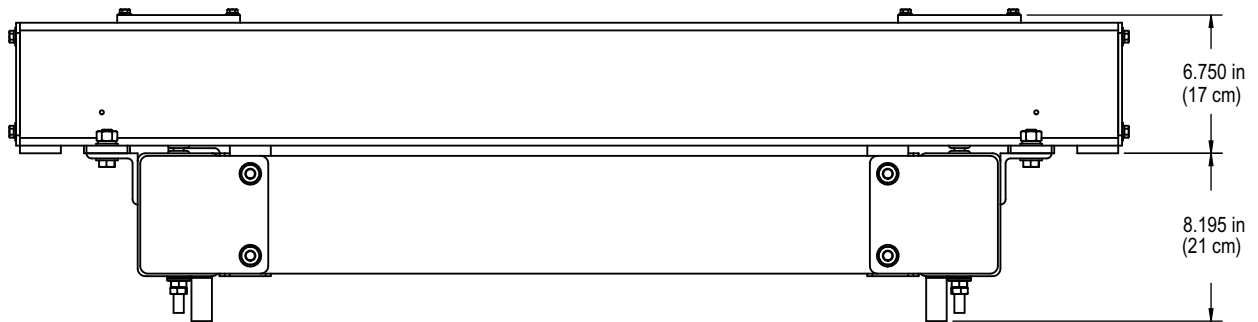

Figure 3-3. 14x Side View

3.3 List Parameters for Belt Scale

Complete the information below for your records.

CUSTOMER	_____
ORDER NUMBER	_____
INSTALLATION	_____
REFERENCE	_____
TYPE weigh frame	_____
TYPE SPEED PICKUP	_____
TYPE ELECTRONICS	_____
DATE	_____
FILLED IN BY	_____

Parameter	Unit	Entered	Change
Nominal capacity (flow)	lb/hr (kg/hr)	_____	_____
Maximum capacity (flow)	lb/hr (kg/hr)	_____	_____
Minimum capacity (flow)	lb/hr (kg/hr)	_____	_____
Ratio weigh frame		_____	_____
Number of load cells		_____	_____
Load Cell capacity (per load cell)	lb (kg)	_____	_____
Load Cell sensitivity	mV/V	_____	_____
Idler spacing	in (mm)	_____	_____
Belt angle of incline	°	_____	_____
Belt speed	ft/s (m/s)	_____	_____
Speed pickup:		_____	_____
Pulses per revolution		_____	_____
Non-driven drum	in (mm)	_____	_____
Total belt length	ft (m)	_____	_____

4.0 Appendix

4.1 Specifications

Standard

Weigh Frame Material	Powder coated mild steel or Stainless Steel SS304 / 316
Weight	Approximately 104 lb (47 kg) not including the idler
Load Cells	4 S-Beam (stainless steel IP67) capacity 2.5K - 5 Klb
	Power supply 5-15 VDC (stabilized from electronics)
	Signal nominal 3 mV/V at 100% load

4.2 Total Load Cell Build Conversion

The 14x has a summed total of four load cells. See [Table 4-1](#).

Individual Load Cell Capacity	Imperial	Metric
2,500 lb	10,000 lb	4,536 kg
5,000 lb	20,000 lb	9,072 kg

Table 4-1. Total Load Cell Build Conversion



© Rice Lake Weighing Systems Content subject to change without notice.

230 W. Coleman St. • Rice Lake, WI 54868 • USA USA: 800-472-6703 • International: +1-715-234-9171