

PC Board REPLACEMENT INSTRUCTIONS

Kit Name	PC Board Replacement Kit
Kit Part Numbers	Residential: 105002028 (RX and RXP Models) Commercial: 105002029 (CX and CXP Models)
Compatible Rinnai Products	For use with SENSEI RX/CX Condensing Tankless Water Heaters

⚠ WARNING Failure to correctly follow these instructions may result in electrocution causing serious injury or death.

Items Inside Product Box

Before installation, please make sure all parts are located inside the product box (Table 1).

Table 1

Item #	Item	Qty
1	PC Board	1
2	Data Transfer Cable	1
3	PC Board Cover (not pictured)	1
4	Screw (not pictured)	1

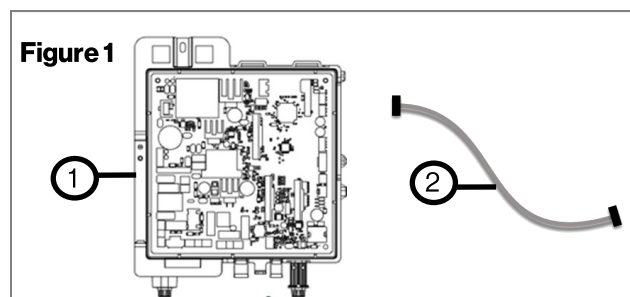

TOOLS/MATERIALS REQUIRED

- Phillips head screwdriver
- Smart Device (such as a smartphone)
- Tankless Water Heater Installation and Operation Manual (supplied with unit or found online at rinnai.us or rinnai.ca)

Instructions

Step 1: Data Collection

Before you begin the data transfer process, follow the procedure below to check each performance data, and the procedure on page 2 to check each parameter setting. Record each value in the "Parameter Settings Table" on page 9. This information will be used to confirm accurate data transfer or to set up manually if the data transfer is unsuccessful.

1. Press and hold the down arrow button (Figure 2).
2. While holding the down arrow button for 2 seconds, press and hold the "On/Off" button (hold both buttons simultaneously) until "01" appears (Figure 2).

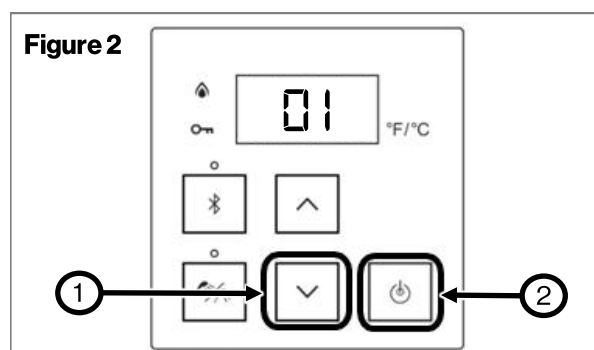

Rinnai

- Use the up and down arrow buttons (Figure 3) to scroll to the desired information described in Table 2 (Performance Data Table).

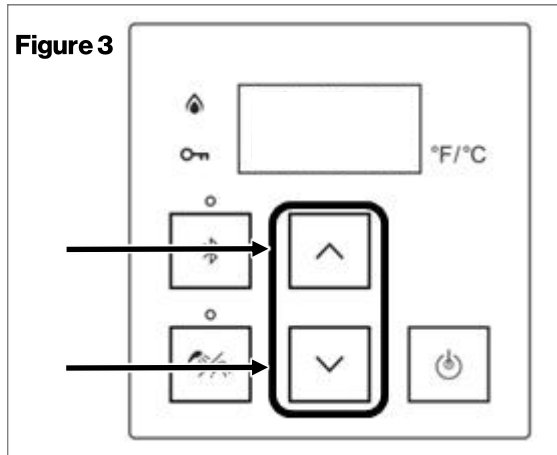

Performance Data Table

Record combustion data below.

Table 2. Performance Data Table

Item #	Data	Collected
03	Combustion Hours (X100)	
04	Combustion Cycles	

- To exit performance data, repeat step 2.
- When complete, the set temperature appears in the display (Figure 4).

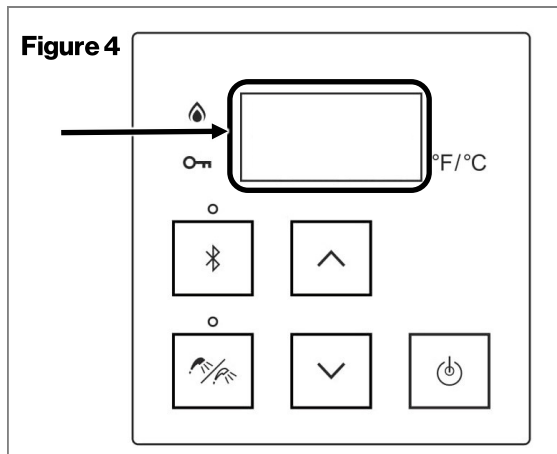

Step 2: Install PC Board and Data Transfer

- Remove the water heater front panel by removing the two screws and releasing the two latches.
- Turn off and disconnect 120 V power supply.
- Locate the PC Board (lower front of unit) (Figure 5).

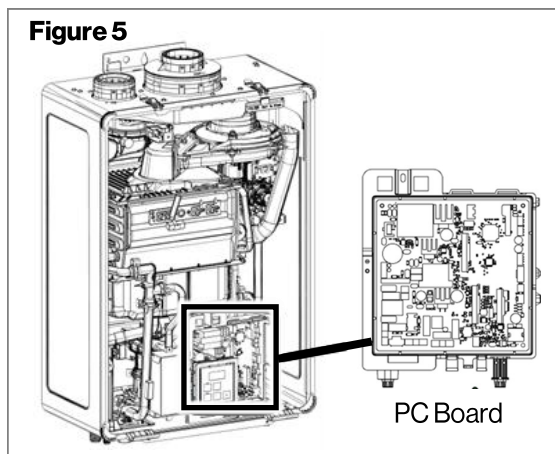

- Remove screw at top of PC Board to remove original PC Board and controller from water heater (Figure 6).

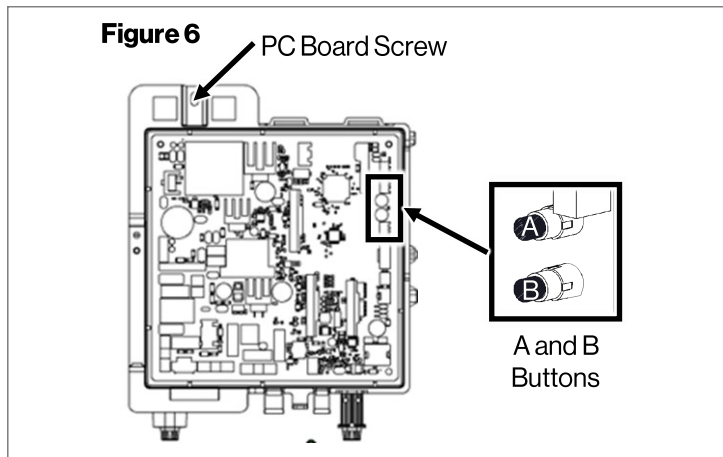

- Disconnect all wire harnesses from original PC Board (Figure 7).

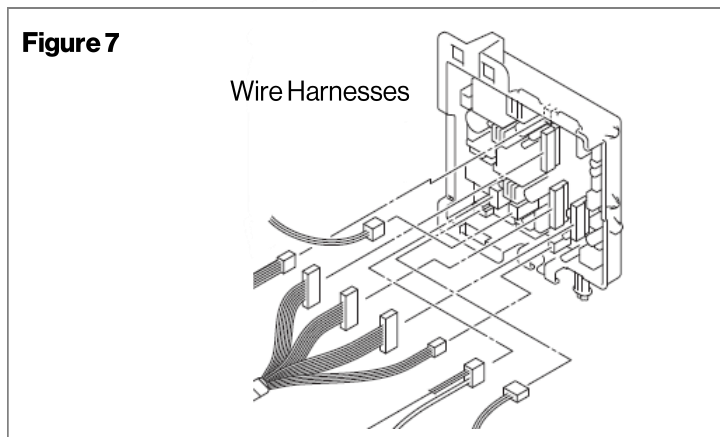

- Set original PC Board and controller aside for future use.
- Connect all wire harnesses to new PC Board (Figure 8). Install new PC Board and controller and secure it by screw (Figure 5).
- Connect Data Transfer Cable (provided) to blue connector at both new PC Board and original PC Board as illustrated in Figure 8.

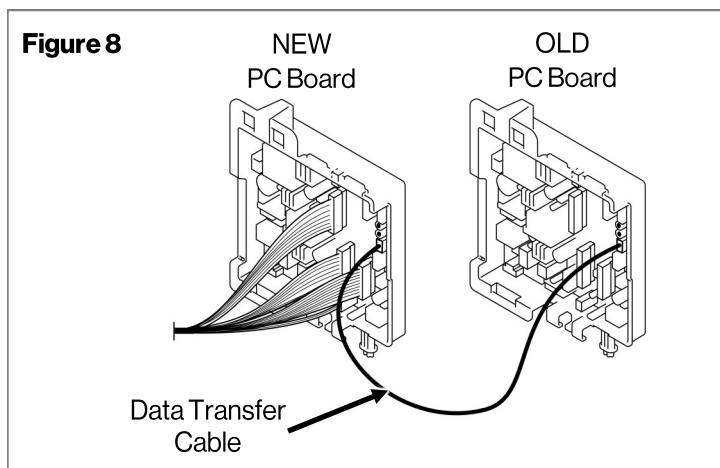

CAUTION ⚡

Do not touch any other areas on the PC board besides the “A” and “B” buttons (Figure 7) as directed while power is supplied to the appliance. Parts of the PC Board are supplied with 120 volts.

9. Reconnect and turn on 120 V power supply and “SEt” appears on controller display.
10. Press “B” button on new PC Board for 1 second (Figure 6) and “dES” appears on controller display.
11. Press “B” button on new PC Board for 1 second (Figure 6) again.
12. When “t” appears on controller display (Figure 9), press “A” button on new PC Board for 1 second.

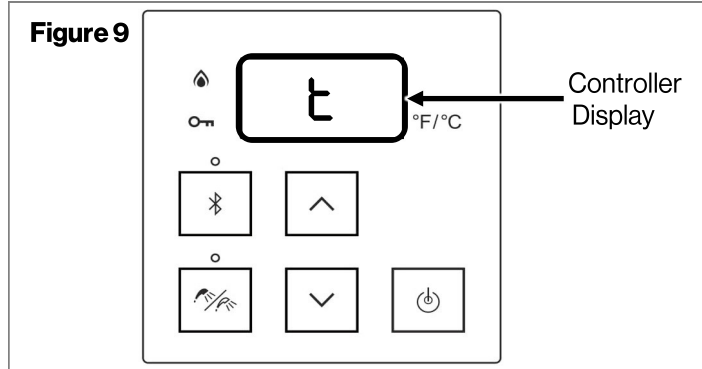

13. The controller will display the set temperature and then flash “PRd”. Use Table 2 to confirm data transfer was successful.

NOTE: If controller displays “bPd” or is blank within 10 seconds, disconnect power and data transfer cable and repeat steps 8 to 13.

If data transfer is repeatedly unsuccessful, proceed to the “Step 2A: Set Parameters Manually” section of these instructions after completing steps 14 through 17. Otherwise, proceed to the Step 3: Enter Gas Valve Parameters.

14. Press “B” button on new PC Board to exit data transfer.
15. Turn off and disconnect 120 V power supply.
16. Disconnect data transfer cable from new PC Board
17. Reconnect and turn on 120 V power supply.

Step 2A: Set Parameters Manually (If Data Transfer Procedure is Unsuccessful)

Set parameters of your tankless water heater by choosing one of the two options below:

- Option 1 (recommended): Set parameters from a smart device using Bluetooth Low Energy (BLE).
- Option 2: Set parameters from the tankless water heater integrated controller.

OPTION 1: USING BLE

To set parameters of your tankless water heater from a smart device using BLE (recommended), follow the steps below:

Note: To utilize BLE, your connecting device (smartphone, tablet, computer, etc.) needs to have Bluetooth 4.0 or newer version. Contact your connecting device manufacturer if you are not sure if your connecting device has Bluetooth 4.0 or newer version.

1. Download the Rinnai Central app by scanning the following QR code:
2. Confirm the controller displays “SEt” and the Priority button LED light on the controller is blinking (Figure 10).
3. Open the Rinnai Central app from your smart device and log in the Rinnai Central app with a professional account.
4. Push the Bluetooth button on the controller. The Bluetooth LED light turns solid.

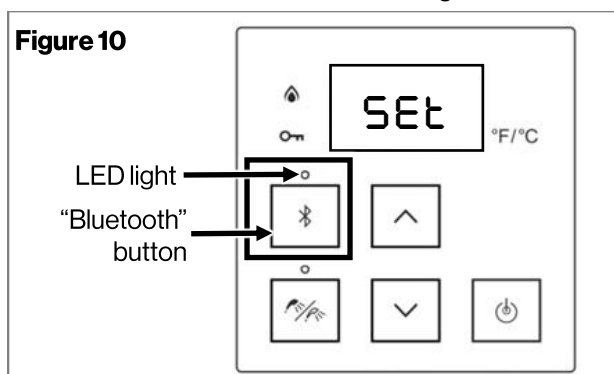

5. Tap “Connect to a Rinnai Appliance” on the Rinnai Central™ app (Figure 11). You will hear a beeping sound when pairing between the app and water heater is established.

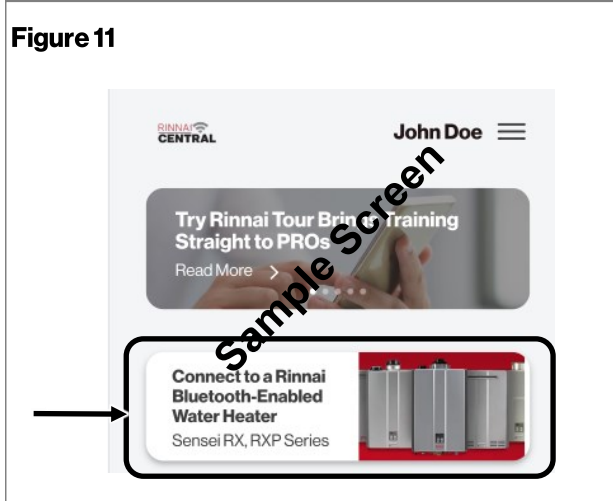

6. Follow the steps in the Rinnai Central app to set parameters of your tankless water heater as you had before.
7. When settings are complete, the controller display will be blank.

OPTION 2: USING INTEGRATED CONTROLLER

1. Supply power to the tankless water heater for the first time. The controller displays “SEt” and the Priority button LED light on the controller is blinking (Figure 12).

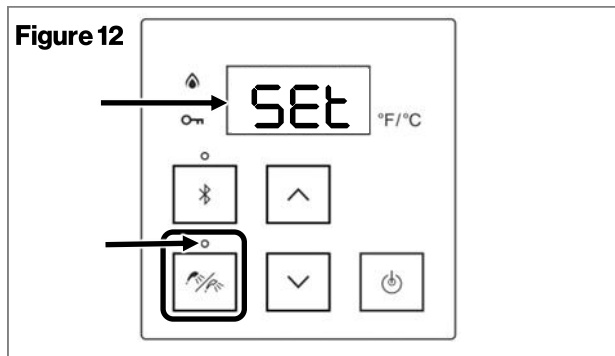

2. Press the “Priority” button. The controller displays “nG” (natural gas) (Figure 13).

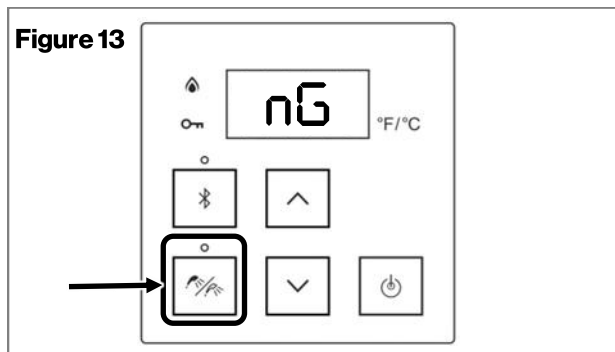

- 3(A). **If using natural gas:** Press the “On/Off” button to confirm natural gas. (Figure 14). Then, proceed to step 4. If using propane gas, skip this step and proceed to step 3(B).

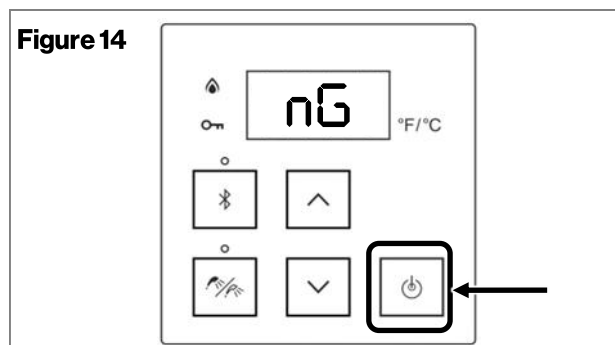

3(B). **If using propane gas:** Press the up or down arrow button. The controller displays “LPG” (Liquid Propane Gas).

Press the “On/Off” button to confirm Liquid Propane Gas (Figure 15). Proceed to step 4.

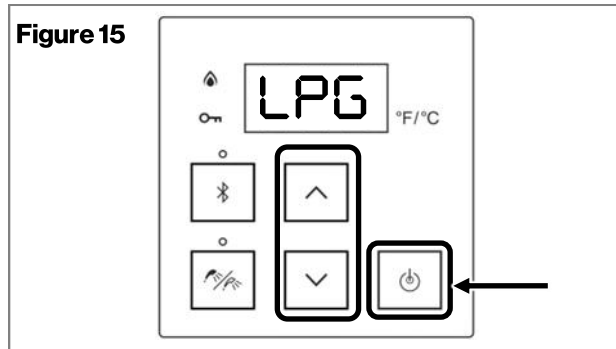

4. The controller displays “In” (indoor) (Figure 16).

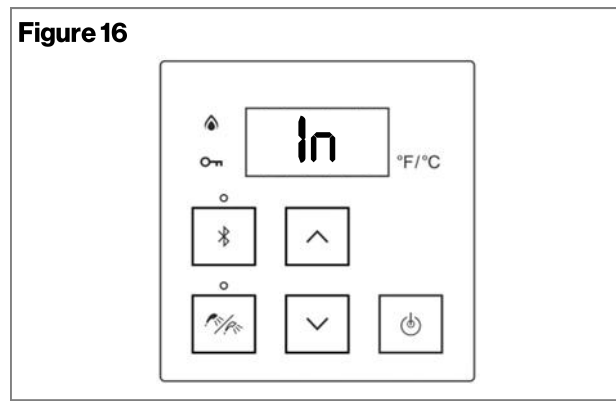

5(A). **If you install the tankless water heater indoors:** Press the “On/Off” button to confirm “In” (Indoor) (Figure 17). Proceed to step 6.

If you install the tankless water heater outdoors with the Rinnai outdoor vent cap, skip this step and proceed to step 5(B).

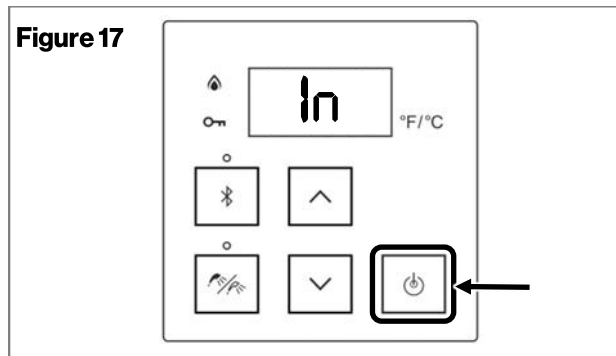

5(B). **If you install the tankless water heater outdoors with the Rinnai outdoor vent cap:** Press the up or down arrow buttons. The controller displays “**Out**” (Outdoor) (Figure 18).

Press the “On/Off” button to confirm “**Out**” (Outdoor).

Proceed to step 6.

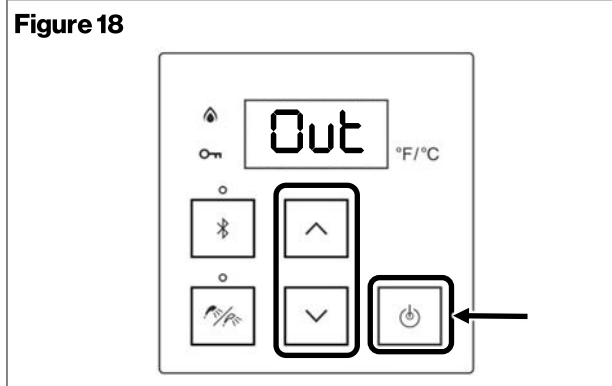

6. The controller displays “**nG**” or “**LPG**”, and “**In**” or “**Out**” alternatively while the “Priority” button is blinking. The controller shows current gas setting and indoor/outdoor setting.

For example, the controller displays “NG” and “In” alternatively, indicating the water heater is set for natural gas and indoor installation. If you need to change these settings, press the up arrow button to go back to step 1. Otherwise, press the “Priority” button (Figure 19).

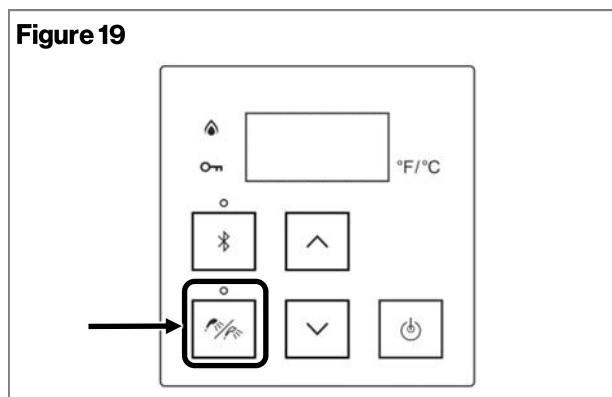

7. The controller briefly displays “**888**” while a beeping sound is observed (Figure 20). Then, complete initial settings and the controller is off.

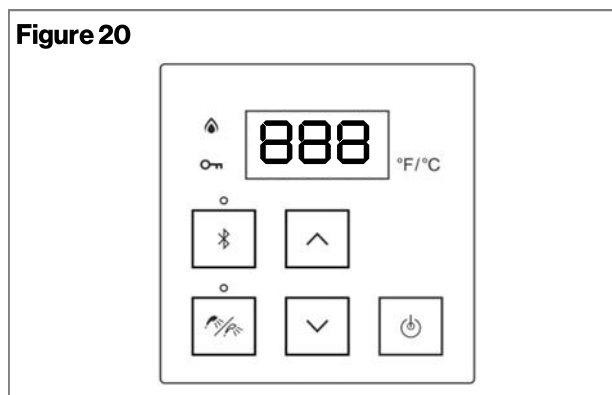

8. Press the "A" button for 1 second (Figure 21).

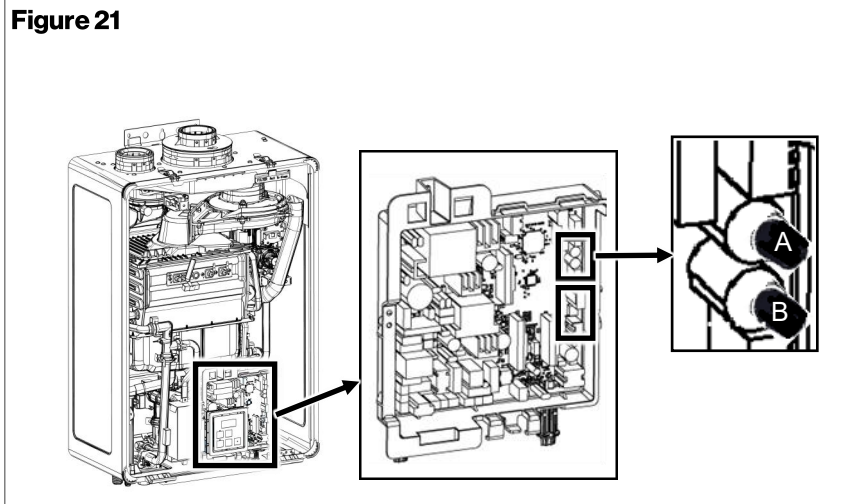

9. Use the up and down arrow buttons on the controller (Figure 22) to select a setting number (See Table 3 on next page).

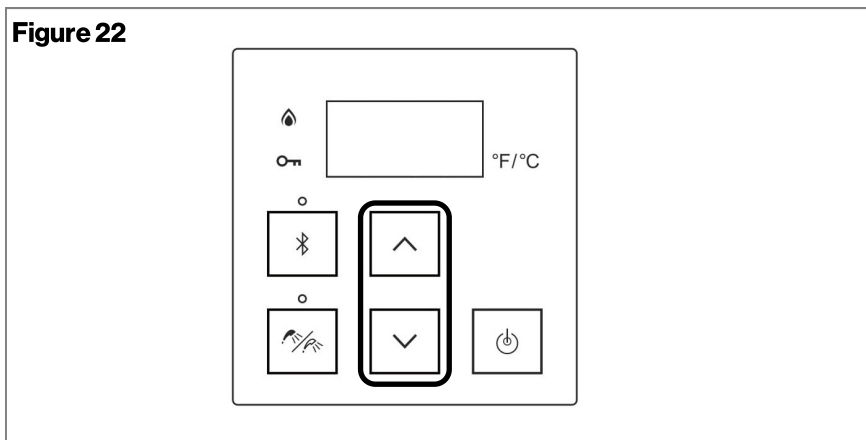

10. Once the desired setting number is selected, use the "On/Off" button (Figure 23) on the controller to change the selection for the setting number.

Example: Display will change from "01a" to "01b" for Maximum Set Temperature setting (as shown in Figure 23).

Complete setting parameters as you recorded.

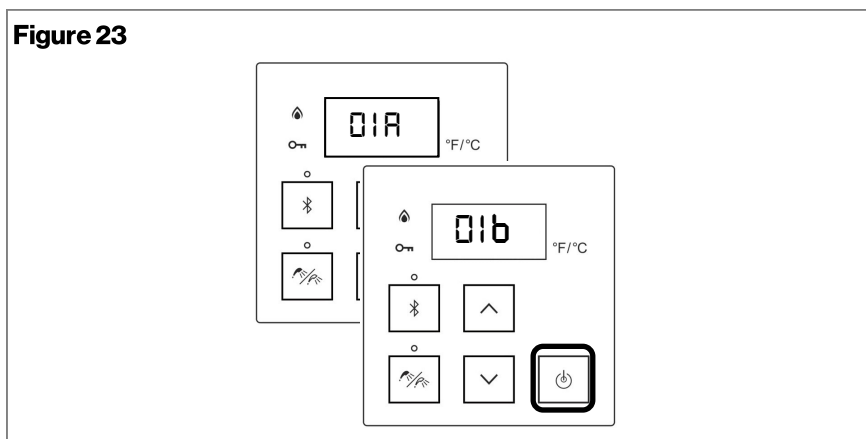

11. To exit the parameters, press the "A" button on the PC board for 1 second (Figure 21). Move to Step 3: Enter Gas Valve Parameters on page 10.

Parameter Settings Table

Table 3. Parameter Settings Table

	Setting Description	Selection					
		A	b	C	d	E	F
01	Maximum Set Temperature	Residential: 120°F (49°C) Commercial: 140°F (60°C)	Residential: 140°F(60°C) Commercial: 185°F(85°C)				
02	High Altitude (Installation Location)	0 - 2,000 ft (0 - 610 m)	2,001 - 5,400 ft (610 - 1,646 m)	5,401 - 7,700 ft (1,646 - 2,347 m)	7,701 - 10,200 ft (2,347 - 3,109 m)		
03	Service Soon ¹	Disabled	0.5 Year	1 Year	2 Years		
04 ³	Recirculation Settings	No Recirculation	Recirculation (Dedicated)	Recirculation (Crossover)			
05	Recirculation Mode ^{2*}	Economy	Comfort	Commercial ⁵			
06	Control Switch	BMS ⁷	Air Handler (AH)				
07	Units in Standby (EZConnect™)	2	1				
08	EZConnect™/ Cascade	Secondary	Primary				
09	Units in Standby (Cascade)	1	2	3	4	5	6
10	Gas Type	NG	LPG				
12	Built-in Pump Setting	Without Pump	With Pump				
13	Water Heater Model (Factory set values and not adjustable)	199 (3237)	180 (2934)	160 (2530)	130 (2024)		
14	Indoor/Outdoor	Internal (Indoor)	External (Outdoor)				
15 ³	Low Activation Mode	On	Off				
16	Pump Speed*	Max	High	Medium	Low		
17 ⁴	First Day Pump Operation*	Off	On				
18 ⁶	Smart-Circ with BLE Button*	Smart-Circ is Disabled	Smart-Circ is Enabled				

* Pump models only.

¹ See section "4.13.2 Service Indicator (Service Soon, 55)" in the "Tankless Water Heater Installation and Operation Manual" for more information.

² Setting 05 is available only if setting 04b or 04C is selected.

- Economy mode cycles the pump less often, using less energy to maintain the circulation loop temperature.
- Comfort mode cycles the pump more frequently, ensuring the loop temperature remains higher (but also uses more energy).

³ Low Activation Mode must be in the ON position (15 A) if crossover recirculation is selected (Parameter 04C).

⁴ For the first 24-hours of operation, Smart-Circ will learn hot water usage patterns and operate pump based on the learned patterns. On the first day, when the tankless water heater has no learned patterns, the unit can be set to no pump operation (Pump Off/No Recirc) for the first 24 hours or to the pump operating (Pump On/Recirc) multiple times per hour depending on setting 05 (Recirculation Mode).

⁵ Commercial mode should not be used for residential applications. Application of commercial mode may result in excessive machine wear and energy consumption.

⁶ To comply with California Title 24, select 18 A (Smart-Circ is disabled).

⁷ BMS = Building Management System

Step 3: Enter Gas Valve Parameters

IMPORTANT

The tankless water heater displays an error code until gas valve values are entered. Enter the gas valve values by following the steps below.

Enter gas valve values by choosing one of the following two options:

Option 1 (Recommended): Enter gas valve values using a Bluetooth®-capable Smart Device.

Option 2: Enter gas valve values from the tankless water heater integrated controller.

Option 1: Enter Gas Valve Values Using a Bluetooth-Capable Smart Device

Note: To utilize Bluetooth Low Energy (BLE), your connecting device (smartphone, tablet, computer, etc.) must have Bluetooth 4.0 or a newer version. Contact your connecting device manufacturer if you are not sure if your connecting device has Bluetooth 4.0 or a newer version.

1. Download the Rinnai Central app by scanning the QR code in Figure 24 if you have not done.

Figure 24

Scan this Code:



2. Open the Rinnai Central™ app from your smart device. Create an account and log in.
3. Push the Bluetooth button on the controller. The Bluetooth LED light turns solid (Figure 25).

Figure 25

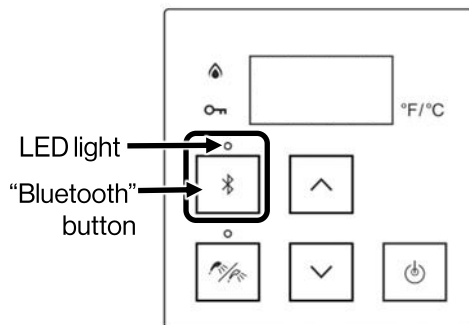

4. Tap "Connect to a Rinnai Appliance" on the Rinnai Central™ app (Figure 26). You will hear a beeping sound when pairing between the app and water heater is established.

Figure 26

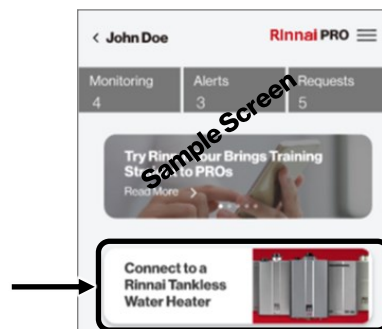

- Follow the steps in the Rinnai Central™ app to scan the QR code on the new gas valve and enter the gas valve values of your tankless water heater (Figure 27). **Note:** Verify “WH” is printed on the bottom, right of label (Figure 27). Otherwise, contact Rinnai at 1-800-621-9419.

Figure 27

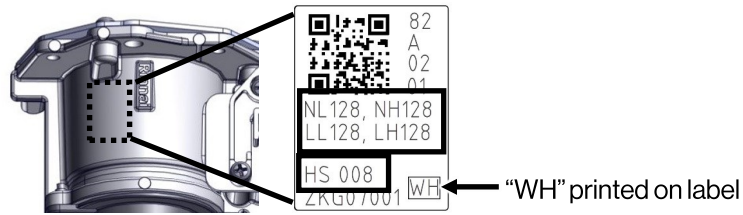

- Restore water supply and gas supply.
- Perform leak detection test for gas.
- After all checks are successfully completed, reinstall the front panel using the two screws and two latches to secure it.
- The PCB replacement process is complete.

Option 2 : Enter Gas Valve Values from Tankless Water Heater Integrated Controller

- Locate the PC board (lower front of unit) (Figure 28).
- Locate the two push buttons (“A” and “B”) on the PC board (Figure 28).
- Press the “B” button for one second (Figure 28).

Figure 28

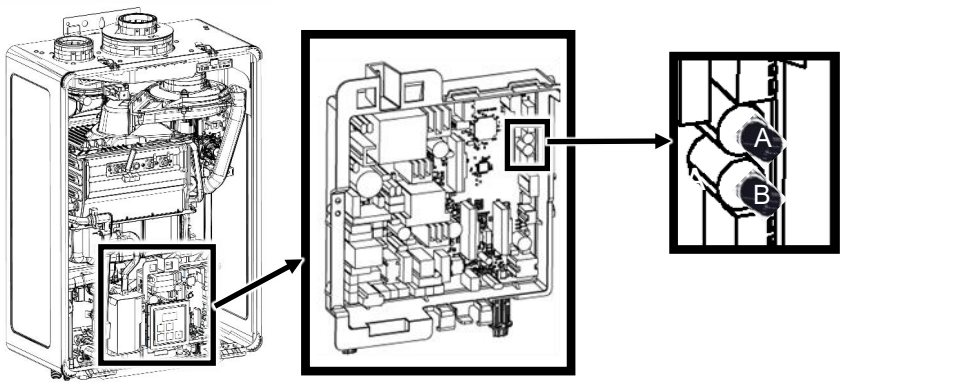

- Press the “B” button twice to confirm the controller displays “Adj” (Adjustment) (Figure 29).

Figure 29

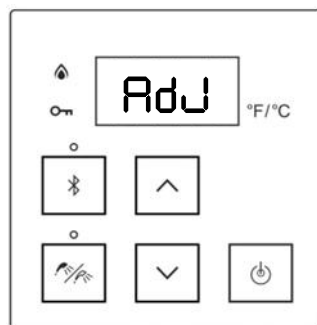

- Press the “A” button (Figure 28 above) to confirm the controller displays “nL” (natural gas low setting) or “LL” (liquid propane low setting) and “--”, alternatively (Figure 30).

Figure 30

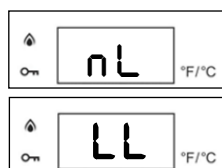

- Press the up and down arrow buttons on the controller until the displayed value matches the value on the label (Figures 27 and 31). Then, press the "A" button (Figure 28).

Figure 31

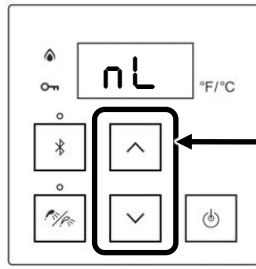

- The controller displays "nH" or "LH" and "--", alternatively. Press the up and down buttons on the controller until the displayed value of "nH" (natural gas high setting) or "LH" (liquid propane high setting) matches the value on the label (Figures 27 and 32). Then, press the "A" button (Figure 28).

Figure 32

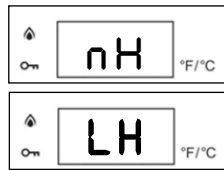

- The controller displays "HS" and "--", alternatively. Press the up and down buttons on the controller until the displayed value of "HS" (Hysteresis setting) matches the value on the label (Figures 27 and 33).

Figure 33



- Press the "A" button to show the entered values (Figure 28). After you confirm all entered values are correct, press the "B" button (Figure 28) for 2 seconds to complete the process.
- Restore water supply and gas supply.

WARNING

Follow the label "For Your Safety Read Before Operating" located one side of your water heater before starting the steps below.

FOR YOUR SAFETY READ BEFORE OPERATING

WARNING If you do not follow these instructions exactly, a fire or explosion may result causing property damage, personal injury or loss of life.

A. This appliance does not have a pilot. It is equipped with an ignition device which automatically lights the burner. Do not try to light the burner by hand.

- If you cannot reach your gas supplier, call the fire department.

B. BEFORE OPERATING, smell all around the appliance area for gas. Be sure to smell next to the floor because some gas is heavier than air and will settle on the floor.

WHAT TO DO IF YOU SMELL GAS

- Do not try to light any appliance.
- Do not touch any electric switch; do not use any phone in your building.
- Immediately call your gas supplier from a neighbor's phone. Follow the gas supplier's instructions.

C. Use only your hand to push in or turn the gas control valve. Never use tools. If the gas control valve will not turn by hand, do not try to repair it, call a qualified service technician. Force or attempted repair may result in a fire or explosion.

D. Do not use this appliance if any part has been under water. Immediately call a qualified service technician to inspect the appliance and to replace any part of the control system and any gas control which has been under water.

FOR YOUR SAFETY READ BEFORE OPERATING

WARNING If you do not follow these instructions exactly, a fire or explosion may result causing property damage, personal injury or loss of life.

A. This appliance does not have a pilot. It is equipped with an ignition device which automatically lights the burner. Do not try to light the burner by hand.

- If you cannot reach your gas supplier, call the fire department.

B. BEFORE OPERATING, smell all around the appliance area for gas. Be sure to smell next to the floor because some gas is heavier than air and will settle on the floor.

WHAT TO DO IF YOU SMELL GAS

- Do not try to light any appliance.
- Do not touch any electric switch; do not use any phone in your building.
- Immediately call your gas supplier from a neighbor's phone. Follow the gas supplier's instructions.

C. Use only your hand to push in or turn the gas control valve. Never use tools. If the gas control valve will not turn by hand, do not try to repair it, call a qualified service technician. Force or attempted repair may result in a fire or explosion.

D. Do not use this appliance if any part has been under water. Immediately call a qualified service technician to inspect the appliance and to replace any part of the control system and any gas control which has been under water.

Check operation of the tankless water heater by using a gas analyzer.

- Remove the rubber cap as shown in Figure 34 and insert a gas analyzer probe (field-supplied) into the opening.

WARNING Exhaust gas may leak from the opening while the burner is on. Exhaust gas contains carbon monoxide and other harmful gases, which can cause personal injury or death. Seal the opening with metal tape or other appropriate methods while the gas analyzer measures the exhaust gas. Also, sufficient ventilation is required to avoid a potential hazardous situation.

Figure 34

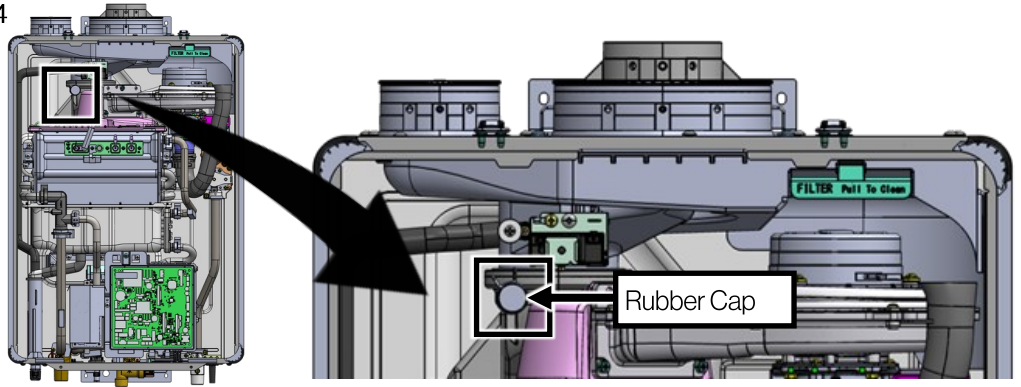

- Press the "On/Off" button on the controller to start the unit (Figure 35).

Set the water temperature to 120°F (49°C) or higher, and turn on two or three faucets or showers. Refer to the "Tankless Water Heater Installation and Operation Manual" for steps on adjusting water temperature.

Figure 35

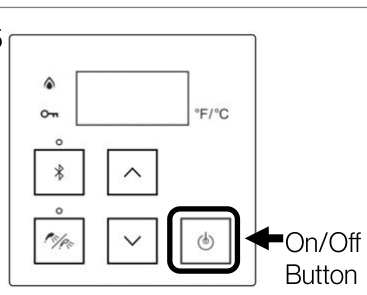

- The combustion fan will begin to run if water is flowing, and the spark will ignite the main burner.
- This water heater has an automatic ignition system. When the main burner is lit, the "In Use" light (Figure 36) will glow red and the spark will stop.

Figure 36

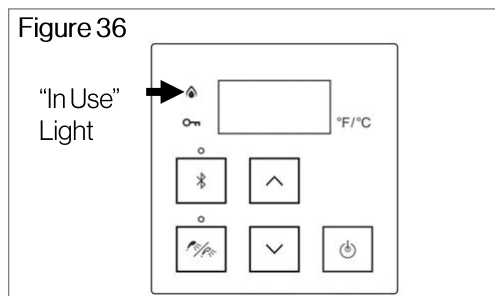

- Let the water heater run for at least five minutes, and then measure the concentration of CO₂ or O₂ by the gas analyzer, as applicable, in the exhaust system.

If combustions exceed the values below:

- Ensure gas type is correct.
- Check exhaust and inlet air for blockage.
- Please call Rinnai Technical Support.

	CO ₂	O ₂
NG	7.0% - 11.0%	1.7% - 8.7%
LPG	7.9% - 11.9%	2.8% - 8.9%

16. If the measured CO₂ or O₂ is within the appropriate range, turn off the water faucets or showers.
17. Turn off the unit by pressing the "On/Off" button on the controller (Figure 35).
18. Reinstall the rubber cap.
19. Reinstall the front panel using the two screws and two latches to secure it.
20. The PCB replacement process is complete.

**CAUTION**

Do not touch the areas at or near the heat exchanger or hot water lines; these areas become hot and could cause burns.

NOTICE:

Your water heater may give an error code 21 when you change gas setting from Natural to LPG or LPG to Natural. If that is the case, complete "Step 3. Enter Gas Valve Parameters".

U362-0951(00)
100000854
1/2024