

ArmorBlock 16-Channel IO-Link Hubs

Catalog Numbers 1732IL-IB16M12, 1732IL-10X6M12, 1732IL-16CFGM12M12L



Important User Information

Read this document and the documents listed in the additional resources section about installation, configuration, and operation of this equipment before you install, configure, operate, or maintain this product. Users are required to familiarize themselves with installation and wiring instructions in addition to requirements of all applicable codes, laws, and standards.

Activities including installation, adjustments, putting into service, use, assembly, disassembly, and maintenance are required to be carried out by suitably trained personnel in accordance with applicable code of practice.

If this equipment is used in a manner not specified by the manufacturer, the protection provided by the equipment may be impaired.

In no event will Rockwell Automation, Inc. be responsible or liable for indirect or consequential damages resulting from the use or application of this equipment.

The examples and diagrams in this manual are included solely for illustrative purposes. Because of the many variables and requirements associated with any particular installation, Rockwell Automation, Inc. cannot assume responsibility or liability for actual use based on the examples and diagrams.

No patent liability is assumed by Rockwell Automation, Inc. with respect to use of information, circuits, equipment, or software described in this manual.

Reproduction of the contents of this manual, in whole or in part, without written permission of Rockwell Automation, Inc., is prohibited

Throughout this manual, when necessary, we use notes to make you aware of safety considerations.



WARNING: Identifies information about practices or circumstances that can cause an explosion in a hazardous environment, which may lead to personal injury or death, property damage, or economic loss.



ATTENTION: Identifies information about practices or circumstances that can lead to personal injury or death, property damage, or economic loss. Attentions help you identify a hazard, avoid a hazard, and recognize the consequence.

IMPORTANT Identifies information that is critical for successful application and understanding of the product.

Labels may also be on or inside the equipment to provide specific precautions.



SHOCK HAZARD: Labels may be on or inside the equipment, for example, a drive or motor, to alert people that dangerous voltage may be present.



BURN HAZARD: Labels may be on or inside the equipment, for example, a drive or motor, to alert people that surfaces may reach dangerous temperatures.



ARC FLASH HAZARD: Labels may be on or inside the equipment, for example, a motor control center, to alert people to potential Arc Flash. Arc Flash will cause severe injury or death. Wear proper Personal Protective Equipment (PPE). Follow ALL Regulatory requirements for safe work practices and for Personal Protective Equipment (PPE).

	Important User Information	2
Preface	Who Should Use This Manual	5
	Purpose of This Manual	5
	Summary of Changes	5
	Additional Resources	6
	Chapter 1	
ArmorBlock 16-Channel IO-Link Hubs	ArmorBlock 16-Channel IO-Link Hubs	7
	IO-Link System	8
	Before You Begin	8
	Module Overview	9
	Chapter 2	
Connect and Operate with IO-Link Masters	Operation with IO-Link Masters	11
	Chapter 3	
Configure Parameters	Activate or Deactivate Block Communication	13
	Restore the IO-Link Hub to Factory Default Settings	13
	Configure IO-Link Device Parameters Using Message Instructions	13
	About the IO-Link Device Parameter Object	14
	Parameters and Identification Information	14
	View IO-Link Hub Identity Details	14
	Change Identification Information	16
	Description of Parameter Data	18
	Parameters for Operation Configuration	19
	Parameters for Input Filter	20
	Parameters for Input Latching	21
	Parameters for Input Logic Settings	22
	Parameters for Output Fault Values	23
	Parameters for Output Fault Delay	24
	Chapter 4	
Diagnostic Properties	Device Status	25
	Parameters for Device Config.	26
	Parameters for General Diagnostic Settings	27
	Device Status in Detail	28
	Chapter 5	
Download and Install IO-Link Device Descriptions	Download the IO-Link Device Description	31
	Register an IODD	31

Configure IO-Link Hub as a Generic IO-Link Device	Appendix A	
	Input and Output Process Data for 1732IL-IB16M12.....	35
	Input Data.....	35
	Output Data.....	36
	Input and Output Process Data for 1732IL-10X6M12.....	36
	Input Data.....	36
	Output Data.....	36
	Input and Output Process Data for 1732IL-16CFGM12M12L...	37
	Input Data.....	37
	Output Data.....	37
	Description of Process Data Terms.....	38
	Configure IO-Link Devices.....	38
	Tag Name Conventions.....	40
Interpret Status Indicators	Appendix B	
	Status Indicator Overview.....	41
	Status Indicator Descriptions.....	42
Wire your IO-Link System	Appendix C	
Recommended Wiring Configurations.....	43	

This manual describes how to use the ArmorBlock® 16-Channel IO-Link hubs.

Make sure that you are familiar with the following:

- Use of a controller in a Logix 5000™ control system
- Studio 5000 Logix Designer® environment

IMPORTANT You must use the RSLogix 5000® and Studio 5000®, version 20 or later, to configure the ArmorBlock IO-Link hubs.

Who Should Use This Manual

This manual is intended for trained and qualified personnel who are responsible for installing, configuring, and troubleshooting the ArmorBlock 16-Channel IO-Link hubs.

Purpose of This Manual

This manual provides information and describes the procedures that are used to configure, operate, and troubleshoot the ArmorBlock 16-Channel IO-Link hubs.

Summary of Changes

This manual was revised to add information about 1732IL-10X6M12 and 1732IL-16CFGM12M12L. This table indicates where new content exists in the manual.

Topic	Page
Added description of features of new IO-Link hubs.	7
Updated Module Overview with features of new IO-Link hubs.	9
Updated description of Operation with IO-Link masters.	11
Added method to restore IO-Link hub to factory settings.	13
Added section about configuring indexes using CIP messaging.	13
Updated Parameters and Identification topic with new tables for 1732IL-10X6M12 and 1732IL-16CFGM12M12L.	14
Grouped indexes 0x0048, 0x0049, and 0x0060 together based on new AOP version.	19
Updated section Parameters for Input Filter.	20
Updated section Parameters for Input Latching.	21
Updated section Parameters for Input Logic Settings.	22
Added section Parameters for Output Fault Values.	23
Added section Parameters for Output Fault Delay.	24
Updated section Device Status.	25
Moved section Parameters for Device Config and added section Parameters for General Diagnostic Settings to Chapter 4.	26
Updated table Event Codes for Peripheral Errors.	28
Updated Appendix A with new topics for 1732IL-10X6M12 and 1732IL-16CFGM12M12L.	35

Topic	Page
Updated tables in Description of Parameter Data Terms with information for 1732IL-10X6M12 and 1732IL-16CFGM12M12L.	38
Added topic Tag Name Conventions.	40
Updated table Status Indicators and Description with new information for 1732IL-10X6M12 and 1732IL-16CFGM12M12L.	42
Added Appendix C, Wire your IO-Link System.	43

Additional Resources

These resources contain information about related products from Rockwell Automation.

Resource	Description
ArmorBlock 16-Channel IO-Link Hubs Installation Instructions, publication 1732IL-IN001	Describes how to install and wire the ArmorBlock IO-Link hubs.
ArmorBlock I/O Selection Guide, publication 1732-SG001	Provides specifications, wiring diagrams, and module block diagrams for ArmorBlock I/O blocks, and IO-Link master and hubs.
ArmorBlock I/O 8-Channel IO-Link Master Module User Manual, publication 1732E-UM007	Describes how to use the ArmorBlock I/O 8-Channel IO-Link Master Module.
POINT I/O 4-Channel IO-Link Master Module User Manual, publication 1734-UM020A-EN-E	Describes how to use the POINT I/O 4-Channel IO-Link Master Module.
Industrial Automation Wiring and Grounding Guidelines, publication 1770-4.1	Provides general guidelines for installing a Rockwell Automation industrial system.
Product Certifications website, http://www.rockwellautomation.com/rockwellautomation/certification/overview.page	Provides declarations of conformity, certificates, and other certification details.

You can view or download publications at <http://www.rockwellautomation.com/literature/>. For Release Notes and other publications specific to your module, search the catalog number of the module. To order paper copies of technical documentation, contact your local Allen-Bradley distributor or Rockwell Automation sales representative.

ArmorBlock 16-Channel IO-Link Hubs

Topic	Page
ArmorBlock 16-Channel IO-Link Hubs	7
IO-Link System	8
Before You Begin	8
Module Overview	9

ArmorBlock 16-Channel IO-Link Hubs

The ArmorBlock 16-Channel IO-Link hubs are used with an IO-link master to add additional I/Os into the system. They are suitable for use in machines and installations with moderate I/O concentration.

The ArmorBlock 16-Channel IO-Link hubs are compact and well built for direct field service in tough industrial environments. The fully sealed housing is made of die-cast zinc to help protect electronic components from environmental factors.

There are three IO-Link hubs with different channel configurations available – 16 digital inputs; 10 digital inputs and 6 digital outputs; and 16 configurable digital inputs/outputs.

IO-Link hubs with digital outputs or configured with outputs feature an Output Fault Value function. This function enables you to configure the behavior of each output channel if there are interruptions or loss of communications.

For electrical connection, the widely adopted M12 connector system is used with M12 A-coded connectors for I/O signals and IO-Link interface.

IO-Link System

IO-Link technology is a worldwide open-standard protocol that integrates sensors into our Connected Enterprise by connecting the IO-Link enabled device into an IO-Link master module. You can deliver data from the sensor directly into a control system efficiently. The flexibility of IO-Link capable sensors allows machines to operate more effectively by providing the controller with diagnostics. In addition to product detection, sensors provide detailed and accurate machine health status to improve uptime.

The IO-Link system is a configuration of IO-Link masters, IO-Link hubs, and IO-Link enabled devices, such as sensors, actuators, and valves. The IO-Link master provides network interface to the controller and controls the communication to the IO-Link enabled devices. The connection between masters, hubs, and devices can be achieved with a standard unshielded connection cable.

You can connect the IO-Link devices directly to the ports of the IO-Link master.

Figure 1 - The IO-Link System Configuration Example

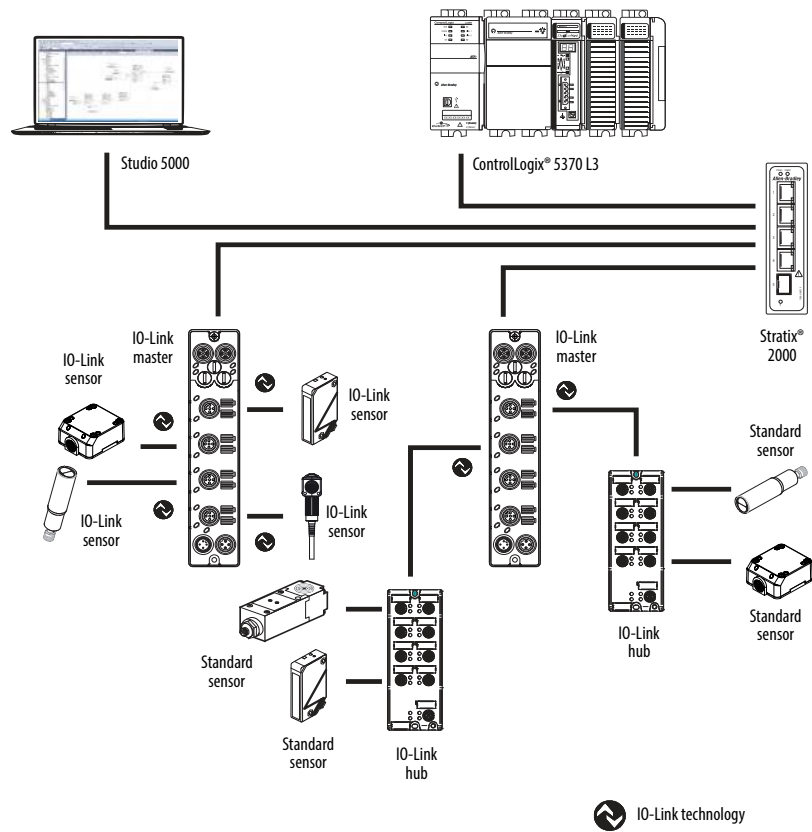

Before You Begin

Before you use ArmorBlock 16-Channel IO-Link hubs, connect the IO-Link hub to the IO-Link master.

For more information on the installation and connection of the IO-Link hub to the IO-Link master, see the ArmorBlock 16-Channel IO-Link Hubs Installation Instructions, publication [1732IL-IN001](#).

Module Overview

The ArmorBlock 16-Channel IO-Link hubs receive binary signals from the devices and transfers them to the controller through the IO-Link master.

- 1732IL-IB16M12 has 16 digital inputs.
- 1732IL-10X6M12 has 10 digital inputs and 6 digital outputs.
- 1732IL-16CFGM12M12L has 16 channels that can be configured as either digital inputs or digital outputs.

The ArmorBlock 16-Channel IO-Link hubs draw power from the following power connectors on the respective hubs.

- 1732IL-IB16M12 draws module and sensor power from U_S .
- 1732IL-10X6M12 draws module and sensor power from U_S , and output power from U_{aux} .
- 1732IL-16CFGM12M12L draws module power from U_S , and sensor and output power from U_L .

Figure 2 - ArmorBlock 16-Channel IO-Link Hubs

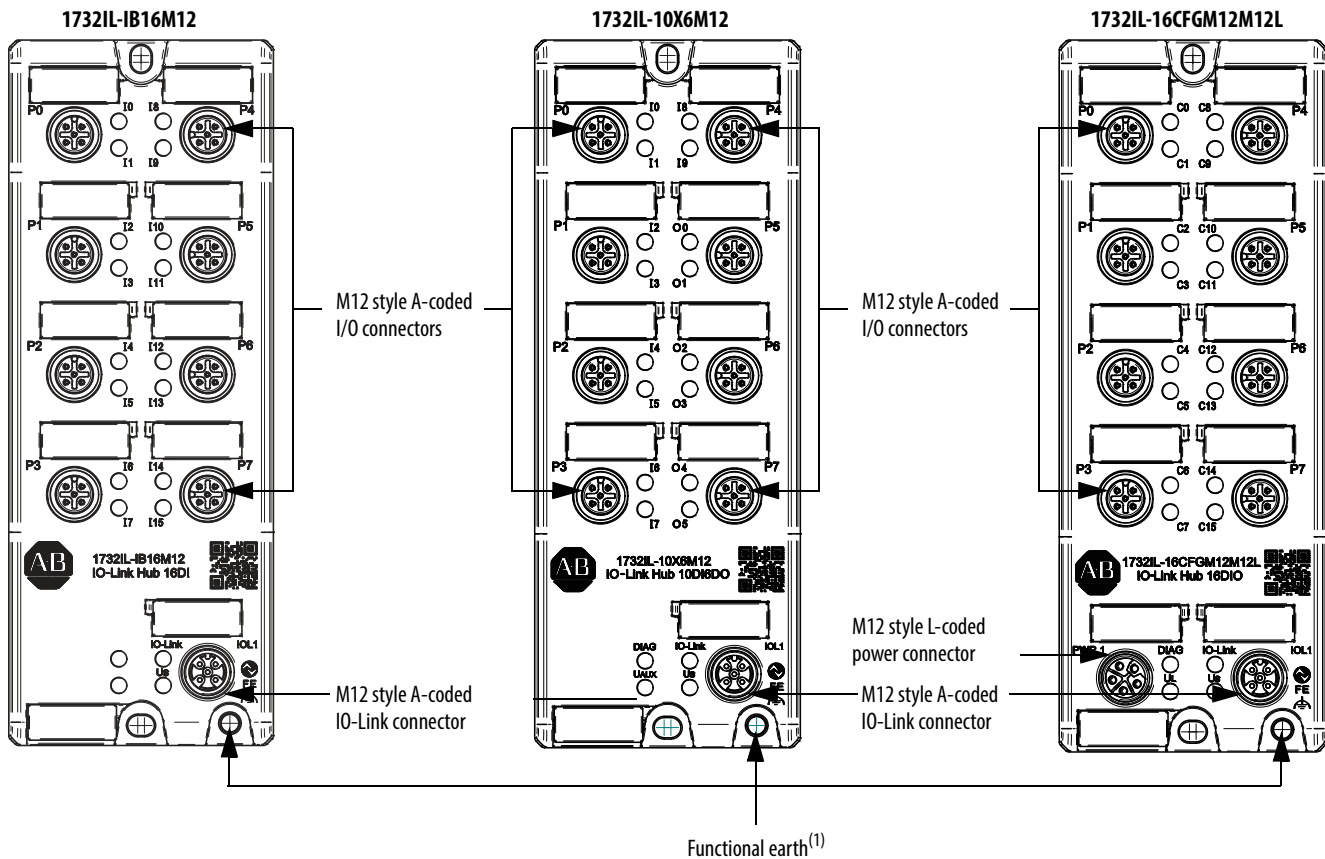

⁽¹⁾ Functional earth is provided for the grounding of field devices and is internally connected to each Pin 5 of the M12 style A-coded I/O ports.

Notes:

Connect and Operate with IO-Link Masters

Topic	Page
Operation with IO-Link Masters	11

Operation with IO-Link Masters

The ArmorBlock 16-Channel IO-Link hubs operate with IO-Link masters via the IO-Link connector. The IO-Link hubs feature 8 x M12 connectors that can support up to 16 digital channels.

Each IO-Link hub takes one IO-Link channel from the IO-Link master. For more information on how to use the IO-Link master, refer to the respective IO-Link master user manual.

If you are using an ArmorBlock IO-Link master, see the ArmorBlock I/O 8-Channel IO-Link Master Module User Manual, publication [1732E-UM007](#).

If you are using a POINT I/O™ IO-Link Master module, see the POINT I/O 4-Channel IO-Link Master Module User Manual, publication [1734-UM020](#).

Notes:

Configure Parameters

Topic	Page
Activate or Deactivate Block Communication	13
Restore the IO-Link Hub to Factory Default Settings	13
Parameters and Identification Information	14
Description of Parameter Data	18

Activate or Deactivate Block Communication

IO-Link enables you to transfer all parameter data from the controller as a block. Activate block communication by using the command “ParamDownLoadStart”, index 0x02, subindex 0, 3. To deactivate block communication, use the command “ParamDownLoadEnd”, index 0x02, subindex 0, 4. For information on how to use a message instruction to get index information, see the ArmorBlock I/O 8-Channel IO-Link Master Module user manual, publication [1732E-UM007](#).

Restore the IO-Link Hub to Factory Default Settings

You can restore your ArmorBlock IO-Link hub to factory default settings by performing one of the following:

- Activate the IO-Link specified system command “Restore factory settings.” The command requires that 0x0082 is written to index 0x02, subindex 0.
- Set output bit “ConfigRST” to “1”. You can also access the bit under index 0x0040, subindex 3, bit 2.
- From the Diagnostics tab in the IO-Link master Add-on Profile (AOP), click “Restore Factory Settings”.

Configure IO-Link Device Parameters Using Message Instructions

Use message instructions to the IO-Link Device Parameter Object to read or change configuration parameters for IO-Link devices with IO-Link Data Description (IODD) Basic or Generic integration.

For more information on how to create a message instruction, see the ArmorBlock I/O 8-Channel IO-Link Master Module user manual, publication [1732E-UM007](#).

About the IO-Link Device Parameter Object

IO-Link device configuration parameters include multiple sets of index/subindex pairs, a length, and a data value that is sent to the IO-Link master through instances of the IO-Link Device Parameter Object. The IO-Link Device Parameter Object provides a mechanism for a CIP™ client to access parameters within an IO-Link device. Within this class, the instance number maps to an IO-Link index value.

The details of each index and subindex depend entirely on the IO-Link device and are described in the IODD XML file for that device.

Parameters and Identification Information

The following tables show direct parameters, identification information, and device access locks for the ArmorBlock IO-Link hubs. These configuration settings are only available in 1732 (AOP) version 3.1.xx or later, and 1734 AOP version 2.1.xx or later.

TIP Not all indexes can be configured in the AOP. However, you can use CIP message instructions to configure all available indexes.

View IO-Link Hub Identity Details

In Studio 5000 Logix Designer® application, you can view the identity details of your ArmorBlock IO-Link hub from the **IO-Link > Common** tab.

Figure 3 - Example of Common Tab in Studio 5000

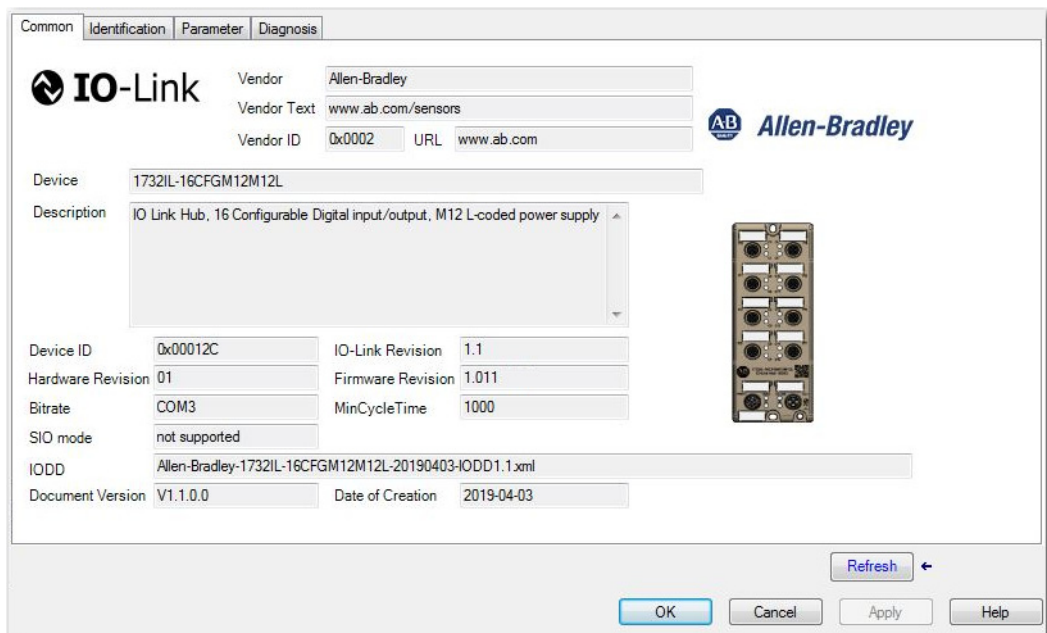

Table 1 - Direct Parameter 1

Index	Subindex	Parameter	Access	Data Length (Byte)	Data Type	Default Value
0x0000	8	Vendor ID1 (MSB)	RO	1	UINT8	0x0002
	9	Vendor ID2 (LSB)				0x00012A = 1732IL-IB16M12, 0x00012B = 1732IL-10X6M12, 0x00012C = 1732IL-16CFGM12M12L
	10	Device ID1 (MSB)				
	11	Device ID2				
	12	Device ID3 (LSB)				

Table 2 - Device Access Locks

Index	Subindex	Parameter	Access	Data Length (Byte)	Data Type	Default Value
0x00C	1	Parameters (write) Access (opt.)	RW	1 bit	Boolean	0
	2	Data storage lock				Lock parameter upload 0 = Unlocked (default) 1 = Locked
	3	Local parameterization (opt.)				0
	4	Local user interface (opt.)				

Change Identification Information

You can change the application specific tag and view the rest of the identity details for your ArmorBlock IO-Link hub from the **IO-Link > Identification** tab.

Figure 4 - Example of Identification Tab in Studio 5000

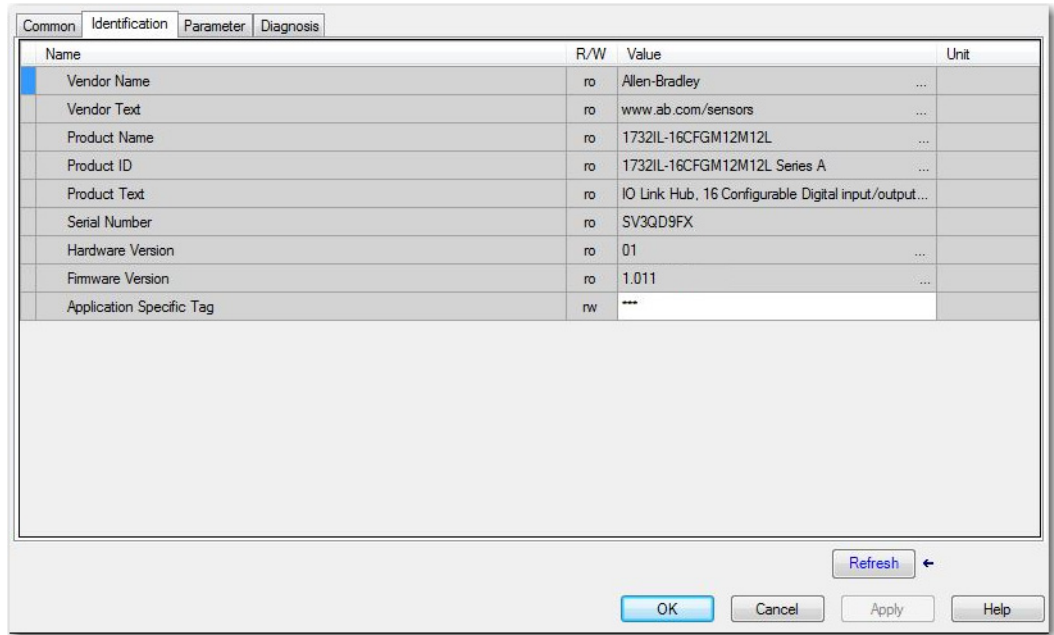

Table 3 - Identification – 1732IL-IB16M12

Index	Subindex	Parameter	Access	Data Length (Byte)	Data Type	Default Value
0x0010	0	Vendor Name	RO	64	String	Allen-Bradley
0x0011		Vendor Text				www.ab.com/sensors
0x0012		Product Name				1732IL-IB16M12
0x0013		Product ID				1732IL-IB16M12 Series A
0x0014		Product Text				IO Link Hub, 16 Point Digital Input
0x0015		Serial Number				16
0x0016		Hardware Version		64		1.0
0x0017		Firmware Version		64		1.011
0x0018		Application Specific Tag		RW		32
0x0019		Electrical Node ID	32	***		
0x001A	Location Tag	32	***			

Table 4 - Identification – 1732IL-10X6M12

Index	Subindex	Parameter	Access	Data Length (Byte)	Data Type	Default Value
0x0010	0	Vendor Name	RO	64	String	Allen-Bradley
0x0011		Vendor Text				www.ab.com/sensors
0x0012		Product Name				1732IL-10X6M12
0x0013		Product ID				1732IL-10X6M12 Series A
0x0014		Product Text				IO Link Hub, 10 Point Digital Input, 6 Point Digital Output
0x0015		Serial Number				SV*****
0x0016		Hardware Version	64	1.0		
0x0017		Firmware Version		1.011		
0x0018		Application Specific Tag	RW	32		***
0x0019		Electrical Node ID	32	***		
0x001A	Location Tag	32	***			

Table 5 - Identification – 1732IL-16CFGM12M12L

Index	Subindex	Parameter	Access	Data Length (Byte)	Data Type	Default Value
0x0010	0	Vendor Name	RO	64	String	Allen-Bradley
0x0011		Vendor Text				www.ab.com/sensors
0x0012		Product Name				1732IL-16CFGM12M12L
0x0013		Product ID				1732IL-16CFGM12M12L Series A
0x0014		Product Text				IO Link Hub, 16 Configurable Digital input/output
0x0015		Serial Number				SV*****
0x0016		Hardware Version	64	1.0		
0x0017		Firmware Version		1.011		
0x0018		Application Specific Tag	RW	32		***
0x0019		Electrical Node ID	32	***		
0x001A	Location Tag	32	***			

Description of Parameter Data

You can view and configure the parameter tags for your ArmorBlock IO-Link hub from the **IO-Link > Parameter** tab.

Figure 5 - Example of Parameter Tab in Studio 5000

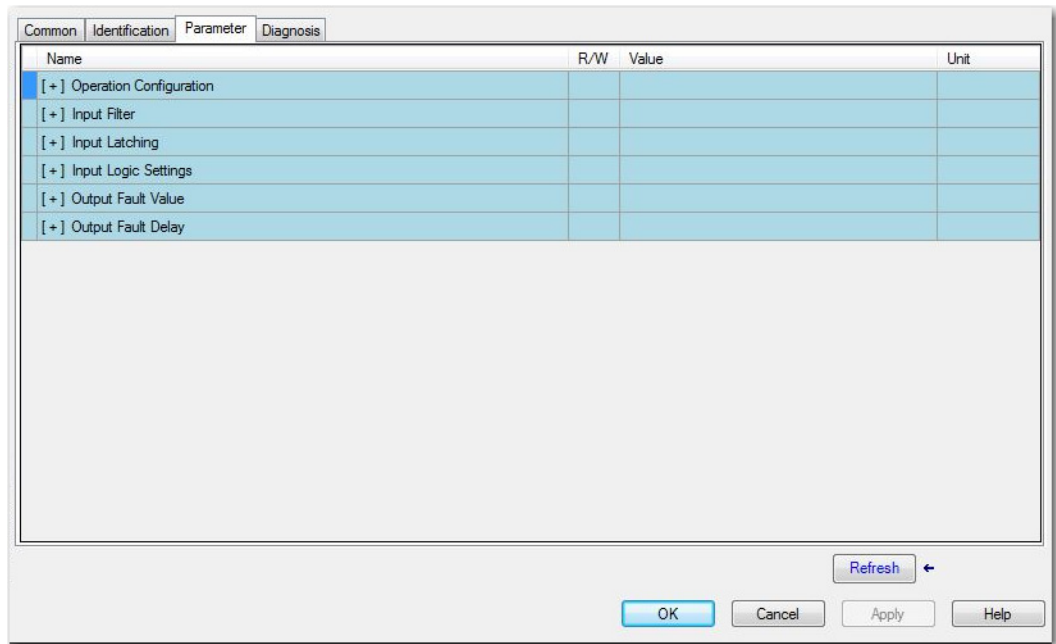

Table 6 - Device Parameters (Individual)

Index	Subindex	Parameter	Access	Data Length (Byte)	Data Type	Default Value
0x0040	1...16	Device Config	RW	1	Boolean	0
0x0041		General Diagnostic Settings		1	Boolean	0
0x0043	1...16	Input Filter		16	UINT8	3 ms
0x0044		Input Latching		16	UINT8	Off
0x0045		Input Logic Settings		16	UINT8	Normal
0x0046 ⁽¹⁾		Output Fault Value		16	UINT8	Low
0x0047 ⁽¹⁾		Output Fault Delay		16	UINT8	80 ms
0x0048	1...16	User Serial Number		16	String	0
0x0060	1	Module Identification ID	1		0	

(1) This index does not apply to 1732IL-IB16.

Parameters for Operation Configuration

These parameters are used to enter information that helps you to identify your module.

Name	R/W	Value	Unit
[-] Operation Configuration			
User Serial Number	rw		
Electrical Node ID tag	rw		
Module Identification ID	rw	0	

Table 7 - Description of Operation Configuration Parameters

Index	Subindex	Bit Number	Parameter
0x0048	1...16	16 x 0...7	User serial number The value entered here is displayed in index 0x0015 (Serial Number). If there is no value entered here, the production serial number is displayed in 0x0015.
0x0049	1...16	16 x 0...7	Electrical Node ID Tag, ASCII text (Default: 16 x 0x00) Enter descriptions and tags for your device.
0x0060	1	0...6	Module Identification ID Assign numerical values to identify which modules are used or connected. This parameter is outside the data storage range.

Parameters for Input Filter

This parameter (FilterTime.Chxx) specifies the filter time for the module inputs. Each input can be configured individually.

Name	R/W	Value	Unit
[-] Input Filter			
FilterTime.Ch0	rw	3ms	
FilterTime.Ch1	rw	3ms	
FilterTime.Ch2	rw	3ms	
FilterTime.Ch3	rw	3ms	
FilterTime.Ch4	rw	3ms	
FilterTime.Ch5	rw	3ms	
FilterTime.Ch6	rw	3ms	

You can configure the filter times for each input channel from the device index 0x0043.

Table 8 - Description of Index 0x0043

Index	Subindex	Bit Number	Channel	IO Number	Parameter Value
0x0043	1	0...3	Ch0	I0, C0	0 = Off 1 = 0.5 ms 2 = 1 ms 3 = 2 ms 4 = 3 ms (default)
	2		Ch1	I1, C1	
	3		Ch2	I2, C2	
	4		Ch3	I3, C3	
	5		Ch4	I4, C4	
	6		Ch5	I5, C5	
	7		Ch6	I6, C6	
	8		Ch7	I7, C7	
	9		Ch8	I8, C8	
	10		Ch9	I9, C9	
	11		Ch10	I10, C10	
	12		Ch11	I11, C11	
	13		Ch12	I12, C12	
	14		Ch13	I13, C13	
	15		Ch14	I14, C14	
	16		Ch15	I15, C15	

Parameters for Input Latching

This parameter (LatchTime.Chxx) specifies the minimum time that the input stays in one value before switching to another. The minimum time is used when for both Input Logic-1 and Input Logic-0 status.

Name	R/W	Value	Unit
[-] Input Latching			
LatchTime.Ch0	rw	off	
LatchTime.Ch1	rw	off	
LatchTime.Ch2	rw	off	
LatchTime.Ch3	rw	off	
LatchTime.Ch4	rw	off	
LatchTime.Ch5	rw	off	
LatchTime.Ch6	rw	off	

You can configure the latch time for each input channel from the device index 0x0044.

Table 9 - Description of Index 0x0044

Index	Subindex	Bit Number	Channel	IO Number	Parameter Value
0x0044	1	0...3	Ch0	I0, C0	0 = Off (default) 1 = 0.5 ms 2 = 1 ms 3 = 2 ms 4 = 3 ms
	2		Ch1	I1, C1	
	3		Ch2	I2, C2	
	4		Ch3	I3, C3	
	5		Ch4	I4, C4	
	6		Ch5	I5, C5	
	7		Ch6	I6, C6	
	8		Ch7	I7, C7	
	9		Ch8	I8, C8	
	10		Ch9	I9, C9	
	11		Ch10	I10, C10	
	12		Ch11	I11, C11	
	13		Ch12	I12, C12	
	14		Ch13	I13, C13	
	15		Ch14	I14, C14	
	16		Ch15	I15, C15	

Parameters for Input Logic Settings

This parameter (Input Logic Settings.Chxx) determines whether the switched input is displayed as NO (normally open) or NC (normally closed).

Name	R/W	Value	Unit
[-] Input Logic Settings			
Input Logic Settings.Ch0	rw	NO	
Input Logic Settings.Ch1	rw	NO	
Input Logic Settings.Ch2	rw	NO	
Input Logic Settings.Ch3	rw	NO	
Input Logic Settings.Ch4	rw	NO	
Input Logic Settings.Ch5	rw	NO	
Input Logic Settings.Ch6	rw	NO	

You can configure the logic for each input channel from the device index 0x0045.

Table 10 - Description of Index 0x0045

Index	Subindex	Bit Number	Channel	IO Number	Parameter Value
0x0045	1	0	Ch0	I0, C0	0 = NO (Normally open) (default) 1 = NC (Normally closed)
	2		Ch1	I1, C1	
	3		Ch2	I2, C2	
	4		Ch3	I3, C3	
	5		Ch4	I4, C4	
	6		Ch5	I5, C5	
	7		Ch6	I6, C6	
	8		Ch7	I7, C7	
	9		Ch8	I8, C8	
	10		Ch9	I9, C9	
	11		Ch10	I10, C10	
	12		Ch11	I11, C11	
	13		Ch12	I12, C12	
	14		Ch13	I13, C13	
	15		Ch14	I14, C14	
	16		Ch15	I15, C15	

Parameters for Output Fault Values

This parameter (Fault Value.Ch xx) determines the behavior of the digital outputs in there is a loss of communications. Each channel can be configured individually.

IMPORTANT The Fault Value function is available only for 1732IL-10X6M12 and 1732IL-16CFGM12M12L.

Name	R/W	Value	Unit
[-] Output Fault Value			
Fault Value.Ch0	rw	Off	
Fault Value.Ch1	rw	Off	
Fault Value.Ch2	rw	Off	
Fault Value.Ch3	rw	Off	
Fault Value.Ch4	rw	Off	
Fault Value.Ch5	rw	Off	
Fault Value.Ch6	rw	Off	

You can configure the value for each output channel from the device index 0x0046.

Table 11 - Description of Index 0x0046

Index	Subindex	Bit Number	Channel	IO Number	Parameter Value
0x0046	1	0...1	Ch0	C0	0 = Off (default) 1 = On
	2		Ch1	C1	
	3		Ch2	C2	
	4		Ch3	C3	
	5		Ch4	C4	
	6		Ch5	C5	
	7		Ch6	C6	
	8		Ch7	C7	
	9		Ch8	C8	
	10		Ch9	C9	
	11		Ch10	00, C10	
	12		Ch11	01, C11	
	13		Ch12	02, C12	
	14		Ch13	03, C13	
	15		Ch14	04, C14	
	16		Ch15	05, C15	

Parameters for Output Fault Delay

This parameter (Fault Delay.Chxx) sets the delay time before an output channel is monitored for possible fault conditions. The delay time starts after a change to the output channel status, and monitoring of the output starts only after the delay time expires. Any fault conditions that occur after this delay are reported as diagnostics. Each channel can be configured individually.

IMPORTANT The Fault Delay function is available only for 1732IL-10X6M12 and 1732IL-16CFGM12M12L.

Name	R/W	Value	Unit
[-] Output Fault Delay			
Fault Delay.Ch0	rw	80	ms
Fault Delay.Ch1	rw	80	ms
Fault Delay.Ch2	rw	80	ms
Fault Delay.Ch3	rw	80	ms
Fault Delay.Ch4	rw	80	ms
Fault Delay.Ch5	rw	80	ms
Fault Delay.Ch6	rw	80	ms

You can configure the value for each output channel from the device index 0x0047.

Table 12 - Description of Index 0x0047

Index	Subindex	Bit Number	Channel	IO Number	Parameter Value
0x0047	1	0...15	Ch0	C0	0...255 ms (default is 80 ms)
	2		Ch1	C1	
	3		Ch2	C2	
	4		Ch3	C3	
	5		Ch4	C4	
	6		Ch5	C5	
	7		Ch6	C6	
	8		Ch7	C7	
	9		Ch8	C8	
	10		Ch9	C9	
	11		Ch10	00, C10	
	12		Ch11	01, C11	
	13		Ch12	02, C12	
	14		Ch13	03, C13	
	15		Ch14	04, C14	
	16		Ch15	05, C15	

Diagnostic Properties

Topic	Page
Device Status	25
Device Status in Detail	28

The ArmorBlock IO-Link hubs provide diagnostic messages to identify the status of the device.

TIP Not all indexes can be configured in the AOP. However, you can use CIP message instructions to configure all available indexes.

Device Status

You can view and configure the diagnostic tags for your ArmorBlock IO-Link hub from the **IO-Link > Diagnosis** tab.

Figure 6 - Example of Diagnosis Tab in Studio 5000

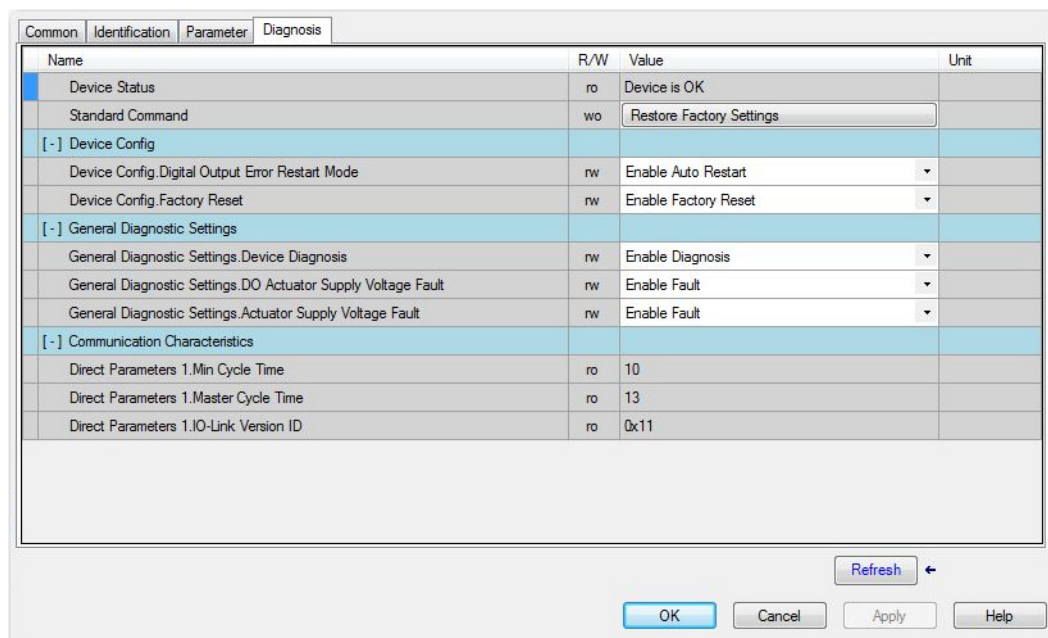

To restore your ArmorBlock IO-Link hub to factory default settings, click Restore Factory Settings.

Table 13 - Description of Index 0x0024

Index	Subindex	Length	Parameter ⁽¹⁾	
			Value	Definition
0x0024	0	Octet	0	Device is operating properly
			1	Maintenance required
			2	Out of specification
			3	Functional check
			4	Failure
			5...255	Reserved

(1) Read-only: Contains the status of the device.

Parameters for Device Config

You cannot access individual subindexes.

Name	R/W	Value	Unit
[-] Device Config			
Device Config.Digital Output Error Restart Mode	rw	Enable Auto Restart	
Device Config.Factory Reset	rw	Enable Factory Reset	

Table 14 - Description of Index 0x0040

Index	Subindex	Bit Number	Parameter
0x0040	1	0	Reserved: do not use
	2	1	Digital Output Error Restart Mode ⁽¹⁾ 0 = Disable, 1 = Enable (default)
	3	2	Factory Reset 0 = Disable, 1 = Enable (default)
	4	3	Reserved: do not use
	5	4	
	6	5	
	7	6	
	8	7	

(1) This parameter does not apply to 1732IL-IB16M12.

Parameters for General Diagnostic Settings

You cannot access individual subindexes.

IMPORTANT The diagnostic function is available only for 1732IL-10X6M12 and 1732IL-16CFGM12M12L.

Name	R/W	Value	Unit
[-] General Diagnostic Settings			
General Diagnostic Settings.Device Diagnosis	rw	Enable Diagnosis ▾	
General Diagnostic Settings.DO Actuator Supply Voltage Fault	rw	Enable Fault ▾	
General Diagnostic Settings.Actuator Supply Voltage Fault	rw	Enable Fault ▾	

Table 15 - Description of Index 0x0041

Index	Subindex	Bit Number	Diagnostic Parameter
0x0041	1	0	Device Diagnosis (for outputs) 0 = Disable, 1 = Enable (default) Diagnostics for inputs are always enabled.
	2	1	DO Actuator Supply Voltage Fault 0 = Disable, 1 = Enable (default)
	3	2	Actuator Supply Voltage Fault 0 = Disable, 1 = Enable (default)
	4	3	Reserved: do not use
	5	4	
	6	5	
	7	6	
	8	7	

Table 16 - Diagnosis Based on 0x0041 Parameter Settings

Actuator Supply Voltage NOK = Supply <5V OK = Supply >18V	DO Actuator Supply Voltage Fault Parameter Value	Actuator Supply Voltage Fault Parameter Value	DO Actuator Supply Voltage Fault Diagnosis	Actuator Supply Voltage Fault Diagnosis
NOK	0	0	Yes ⁽¹⁾	Yes
NOK	0	1	Yes ⁽¹⁾	No
NOK	1	0	No ⁽¹⁾	Yes
NOK	1	1	No ⁽¹⁾	No
OK	0	0	Yes ⁽²⁾	Yes
OK	0	1	Yes ⁽²⁾	No
OK	1	0	No ⁽²⁾	Yes
OK	1	1	No ⁽²⁾	No

(1) There must be at least one output set logically.

(2) There must be at least one output set logically, and an overload or short-circuit is detected.

Device Status in Detail

The following table describes the status of the device in detail. These indexes cannot be configured in the AOP, but you can configure them by using CIP message instructions.

Table 17 - Description of Index 0x0025

Index	Subindex	Length	Parameter ⁽¹⁾				
			Subindex	Object Name	Data Type	Comment	
0x0025	1...24	Array T	1	Error_Warning_1	3 octets	All octets 0x00: no error/warning Octet 1: Event qualifier ⁽²⁾ Octet 2, 3: Event code ⁽³⁾	
			2	Error_Warning_2	3 octets		
			3	Error_Warning_3	3 octets		
			4	Error_Warning_4	3 octets		
			:	:	:		:
			n	Error_Warning_n	3 octets		

- (1) Read-only: Contains the detailed status of the device.
- (2) See [Table 18](#) for more information about event qualifiers.
- (3) See [Table 19](#) for more information about event codes for peripheral errors.

Table 18 - Event Qualifier

Bits	Description	Parameters	
		Value	Definition
b7...b6	Mode	0	Reserved
		1	Event single shot
		2	Event disappears
		3	Event appears
b5...b4	Type	0	Reserved
		1	Notification
		2	Warning
		3	Error
b3	Source	0	Device (remote)
		1	Master (local)
b2...b0	Instance	0	Unknown
		1...3	Reserved
		4	Application
		5...7	Reserved

Table 19 - Event Codes for Peripheral Errors

Event Code	Type	Device Status	Description ⁽³⁾
0x5111	Warning	2	Low voltage sensor (U _S)
0x5112 ⁽¹⁾	Warning	2	Low voltage actuator (U _{AUX})
0x7710	Error	4	Sensor error (short-circuit)
0x8CA0 ⁽¹⁾⁽²⁾	Error	4	Sensor error (short-circuit)
0x8CA1 ⁽¹⁾⁽²⁾	Error	4	Sensor error (short-circuit)

Table 19 - Event Codes for Peripheral Errors

Event Code	Type	Device Status	Description ⁽³⁾
0x8CA2 ⁽¹⁾⁽²⁾	Error	4	Sensor error (short-circuit)
0x8CA3 ⁽¹⁾⁽²⁾	Error	4	Sensor error (short-circuit)
0x8CA4 ⁽¹⁾⁽²⁾	Error	4	Sensor error (short-circuit)
0x8CA5 ⁽¹⁾⁽²⁾	Error	4	Sensor error (short-circuit)
0x8CA6 ⁽¹⁾⁽²⁾	Error	4	Sensor error (short-circuit)
0x8CA7 ⁽¹⁾⁽²⁾	Error	4	Sensor error (short-circuit)
0x8CB0 ⁽¹⁾⁽²⁾	Error	4	Output error C0
0x8CB1 ⁽¹⁾⁽²⁾	Error	4	Output error C1
0x8CB2 ⁽¹⁾⁽²⁾	Error	4	Output error C2
0x8CB3 ⁽¹⁾⁽²⁾	Error	4	Output error C3
0x8CB4 ⁽¹⁾⁽²⁾	Error	4	Output error C4
0x8CB5 ⁽¹⁾⁽²⁾	Error	4	Output error C5
0x8CB6 ⁽¹⁾⁽²⁾	Error	4	Output error C6
0x8CB7 ⁽¹⁾⁽²⁾	Error	4	Output error C7
0x8CB8 ⁽¹⁾⁽²⁾	Error	4	Output error C8
0x8CB9 ⁽¹⁾⁽²⁾	Error	4	Output error C9
0x8CBA ⁽¹⁾	Error	4	Output error C10/00
0x8CBB ⁽¹⁾	Error	4	Output error C11/01
0x8CBC ⁽¹⁾	Error	4	Output error C12/02
0x8CBD ⁽¹⁾	Error	4	Output error C13/03
0x8CBE ⁽¹⁾	Error	4	Output error C14/04
0x8CBF ⁽¹⁾	Error	4	Output error C15/05

(1) These event codes do not apply to 1732IL-IB16M12.

(2) These event codes do not apply to 1732IL-10X6M12.

(3) For output errors, Cxx and 0xx indicate the channel/output number.

Table 20 - Error Codes for Access Management

Error Codes for Access Management	Description
0x8011	Index is not available
0x8012	Subindex is not available
0x8023	Access denied
0x8033	Parameter length overrun
0x8034	Parameter length underrun
0x8035	Function not available

Notes:

Download and Install IO-Link Device Descriptions

Topic	Page
Download the IO-Link Device Description	31

An IO-Link Device Description (IODD) file is a set of multiple files including a file in XML format, which describes all parameters that are associated with the device. The IODD set also includes graphic image files of the device and the vendor logo.

Download the IO-Link Device Description

You can find the matching device description file for every ArmorBlock IO-Link module from the following locations:

- [Rockwell Automation Product Compatibility and Download Center \(PCDC\)](#)
- IO-Link community download area: <https://ioddfinder.io-link.com/>



ATTENTION: We recommend that you download and install the most up-to-date version of the relevant IODD from the PCDC or the community download area.

For more information about the registration and the addition of IODD to the IO-Link channel, see the respective IO-Link Master user manual.

Register an IODD

Before you proceed with this task, take note that:

- Only IODD files that are based on IO-Link specification v1.0.1 or v1.1 can be registered.
- You need administrator rights for the machine where the Add-on Profile is installed to be able to register an IODD file.

To register an IODD file:

1. From the IO-Link tab, in the Channel tree, right-click on the IO-Link channel.
2. Select Register IODD.
The following dialog box appears.

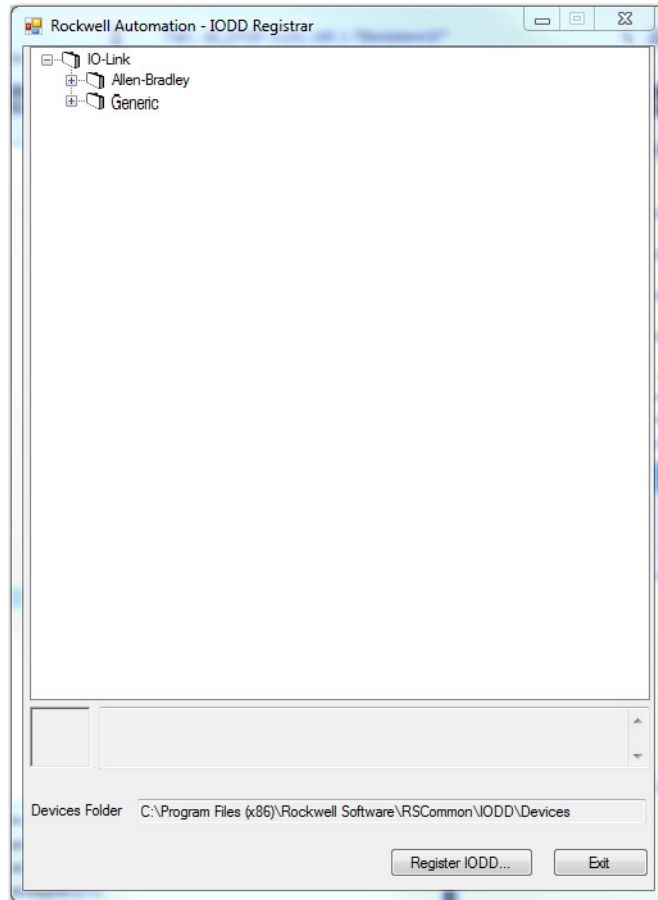

3. Click Register IODD.

The following dialog box appears.

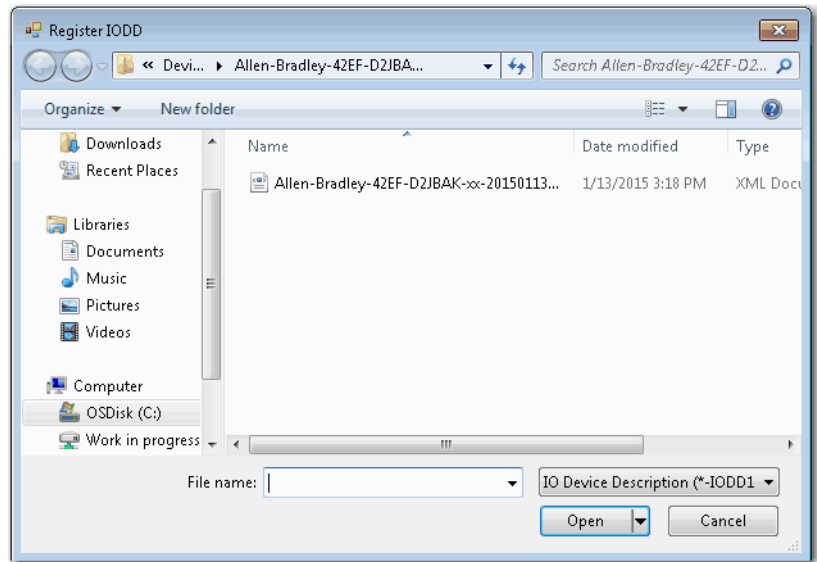

4. Locate the IODD XML file, and then click Open.

This returns you to the previous dialog box that shows the tree list view of registered IODD files.

5. Click Exit.

Notes:

Configure IO-Link Hub as a Generic IO-Link Device

Topic	Page
Input and Output Process Data for 1732IL-IB16M12	35
Input and Output Process Data for 1732IL-10X6M12	36
Input and Output Process Data for 1732IL-16CFGM12M12L	37
Configure IO-Link Devices	38
Tag Name Conventions	40
Description of Process Data Terms	38

This appendix describes how to assign process data from the controller to the I/O channels of your IO-Link hub. It also shows the process data length and the structure of the data.

You do not need to configure the IO-Link hub as a generic IO-link device if you register the IODD and use a specific IO-Link hub catalog number. To register the IODD files, see the [Register an IODD on page 31](#).

TIP You are not allowed to change the process data length.

Input and Output Process Data for 1732IL-IB16M12

Input Data

The 1732IL-IB16M12 hub provides up to four bytes of input data. The input process image is mapped in the first two bytes (bytes 0 and 1) as shown in the following table.

Table 21 - Input Process Data – 1732IL-IB16M12

	Bit 7	Bit 6	Bit 5	Bit 4	Bit 3	Bit 2	Bit 1	Bit 0
Byte 0	I14	I12	I10	I8	I6	I4	I2	I0
Byte 1	I15	I13	I11	I9	I7	I5	I3	I1
Byte 2	PortError				ModuleOutputError ⁽¹⁾	ModuleInputError	ModuleActualPwrLow ⁽¹⁾	ModuleSensorPwrLow
Byte 3	UserConfig	Module_ID						

(1) These parameters do not apply to 1732IL-IB16M12.

Output Data

The 1732IL-IB16M12 hub also provides up to four bytes of output data.

Table 22 - Output Process Data – 1732IL-IB16M12

	Bit 7	Bit 6	Bit 5	Bit 4	Bit 3	Bit 2	Bit 1	Bit 0
Byte 0	—							
Byte 1	—							
Byte 2	—							
Byte 3	ConfigRST	—						

Input and Output Process Data for 1732IL-10X6M12

Input Data

The 1732IL-10X6M12 hub provides up to four bytes of input data. The input process image is mapped in the first two bytes (bytes 0 and 1) as shown in the following table.

Table 23 - Input Process Data – 1732IL-10X6M12

	Bit 7	Bit 6	Bit 5	Bit 4	Bit 3	Bit 2	Bit 1	Bit 0
Byte 0	—			18	16	14	12	10
Byte 1	—			19	17	15	13	11
Byte 2	PortError				ModuleOutputError	ModuleInputError	ModuleActuatorPwrLow	ModuleSensorPwrLow
Byte 3	UserConfig	Module_ID						

Output Data

The 1732IL-10X6M12 hub also provides up to four bytes of output data. The output process image is mapped in the first two bytes (bytes 0 and 1) as shown in the following table.

Table 24 - Output Process Data – 1732IL-10X6M12

	Bit 7	Bit 6	Bit 5	Bit 4	Bit 3	Bit 2	Bit 1	Bit 0
Byte 0	04	02	00	—				
Byte 1	05	03	01	—				
Byte 2	—							
Byte 3	ConfigRST	—						

Input and Output Process Data for 1732IL-16CFGM12M12L

Input Data

The 1732IL-16CFGM12M12L hub provides up to four bytes of input data. The input process image is mapped in the first two bytes (bytes 0 and 1) as shown in the following table.

Table 25 - Input Process Data – 1732IL-16CFGM12M12L

	Bit 7	Bit 6	Bit 5	Bit 4	Bit 3	Bit 2	Bit 1	Bit 0
Byte 0	C14	C12	C10	C8	C6	C4	C2	C0
Byte 1	C15	C13	C11	C9	C7	C5	C3	C1
Byte 2	PortError				ModuleOutputError	ModuleInputError	ModuleActuatorPwrLow	ModuleSensorPwrLow
Byte 3	UserConfig	Module_ID						

Output Data

The 1732IL-16CFGM12M12L hub also provides up to four bytes of output data. The output process image is mapped in the first two bytes (bytes 0 and 1) as shown in the following table.

Table 26 - Output Process Data – 1732IL-16CFGM12M12L

	Bit 7	Bit 6	Bit 5	Bit 4	Bit 3	Bit 2	Bit 1	Bit 0
Byte 0	C14	C12	C10	C8	C6	C4	C2	C0
Byte 1	C15	C13	C11	C9	C7	C5	C3	C1
Byte 2	—							
Byte 3	ConfigRST	—						

Description of Process Data Terms

The following table lists the definition for terms that are used in the input process data and output process data tables for the ArmorBlock IO-Link hubs.

Table 27 - Description of Terms in Process Data Tables

Process Data	Definition	
I0...I15	Refers to the status of the input channel.	
O0...O4	Refers to the status of the output channel.	
C0...C15	Refers to the status of the configurable channel.	
ModuleSensorPwrLow	System/sensor power supply voltage is < 18V	
ModuleActuatorPwrLow ⁽¹⁾	Output power supply voltage is < 18V	
ModuleInputError	Sensor error (short-circuit or overload)	
ModuleOutputError ⁽¹⁾	Output error (short-circuit or overload)	
PortError	When ModuleSensorPwrLow is true, the value of PortError is 1 (Byte 2, bits 4...7). Individual port error is not available.	
Module_ID	ID byte for identification of a module change. 0 = not used, Module_ID = 1...127	
UserConfig	Possible values	
	1	Parameters are configured with non-default values.
	0	Parameters are using default values.
ConfigRST	Reset to factory settings for configuration 50 ms after detection of the signal "1".	

(1) This parameter does not apply to 1732IL-IB16M12.

Configure IO-Link Devices

You can configure a generic IO-Link device using Studio 5000. The following example shows how to configure the 1732IL-IB16M12 as a generic IO-Link device.

- In the channel tree, right-click on the IO-Link channel, and then select Change.
Alternatively, click Change on the working pane.

The following dialog box appears.

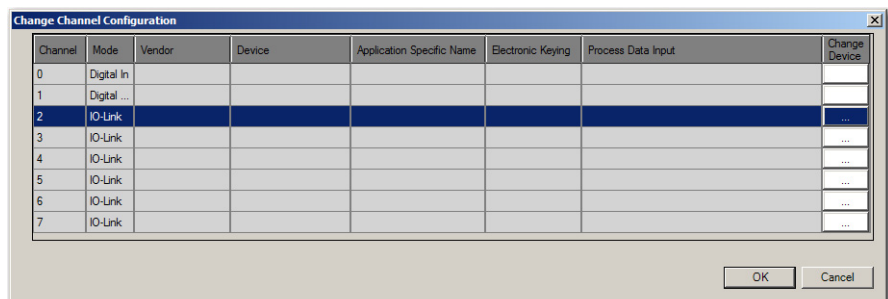

- Click the button in the Change Device column for the IO-Link channel.

The Select IO-Link Device dialog box appears.

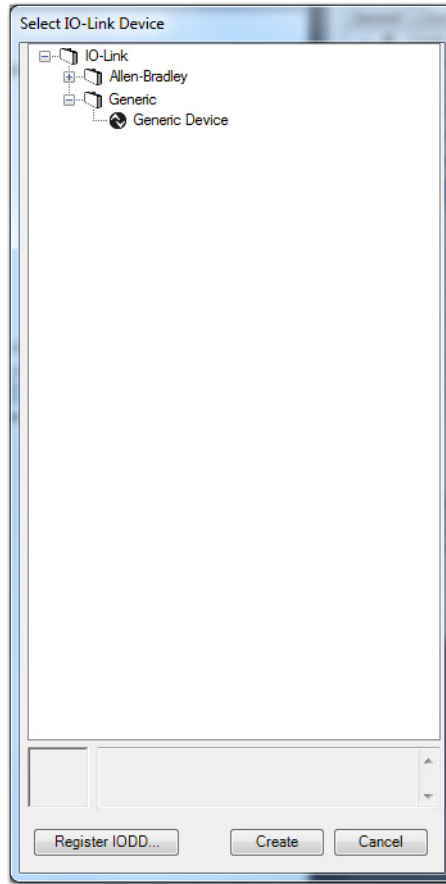

3. Select Generic Device from the tree and click Create.
4. From the dialog box that appears, type the following values in the correct text boxes, and click OK.
Vendor ID: 2
Device ID: 298
Input Length: 4
Output Length: 4

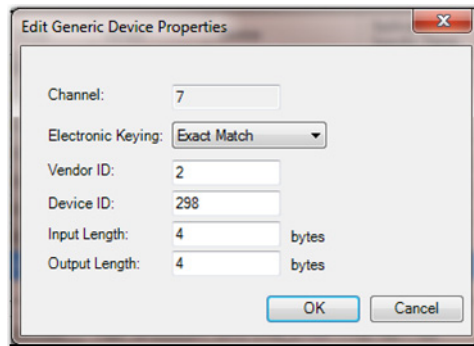

Tag Name Conventions

The module tag names use defined naming conventions. The conventions are as follows:

Tag name examples = IOL:I.Ch3.ModuleSensorPwrLow and IOL:I.Ch3Ch8

- IOL = name of the IO-Link master in your system
- I = tag type

The possible tag types are I (input) and O (output).

- Ch3 = channel number of the IO-Link master
- ModuleSensorPwrLow = tag function
- Ch8 = channel number of the IO-Link hub

In this case, ModuleSensorPwrLow signifies that sensor power supply voltage is less than 18V. For a list of tag functions available for IO-Link hub, see [Description of Terms in Process Data Tables on page 38](#).

Interpret Status Indicators

Topic	Page
Status Indicator Overview	41
Status Indicator Descriptions	42

Status Indicator Overview

See the following figure to identify the location of the status indicators.

Figure 7 - Status Indicators

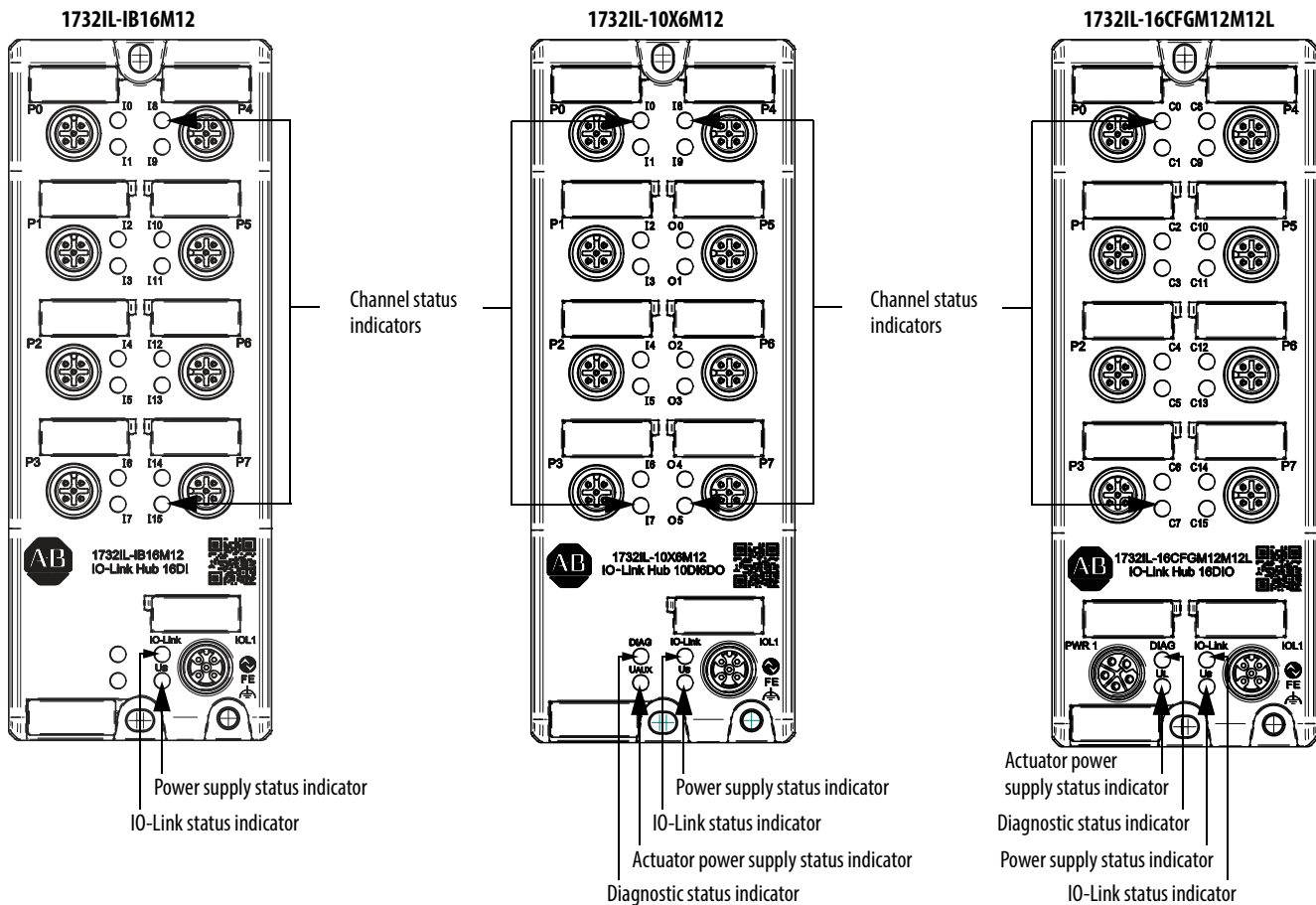

Status Indicator Descriptions

The following table describes the meaning of colors and flashes produced by the status indicators.

Table 28 - Status Indicators and Descriptions

Status Indicator	Color	Description
IO-Link status	Off	Power off.
	Flashing green	IO-Link communication is running.
	Green	Port is starting up (pre-operate).
	Red	Hardware fault.
Sensor power/Module supply status	Off	Power supply is off.
	Green	Power supply is operating normally.
	Red	Power supply is < 18V ±1V.
Output power supply status ⁽¹⁾	Off	Power supply is off.
	Green	Power supply is operating normally.
	Red	Power supply is < 18V ±1V.
I/O status (1 status indicator per channel)	Off	The input or output is in the off state.
	Yellow for even channels; White for odd channels	The input or output is in the on state.
	Red	Hardware fault.
Diagnostic status ⁽¹⁾	Off	No error message exists.
	Red	Module diagnosis available.

(1) These indicators do not apply to 1732IL-IB16M12.

Wire your IO-Link System

Topic	Page
Recommended Wiring Configurations	43

Recommended Wiring Configurations

The following figures show how to connect your IO-Link master to ArmorBlock IO-Link hubs. For more information on the types of cables and receptacles available, see the ArmorBlock I/O Selection Guide, publication [1732-SG001](#).

Figure 8 - Example of Wiring from ArmorBlock IO-Link Master to ArmorBlock IO-Link Hub

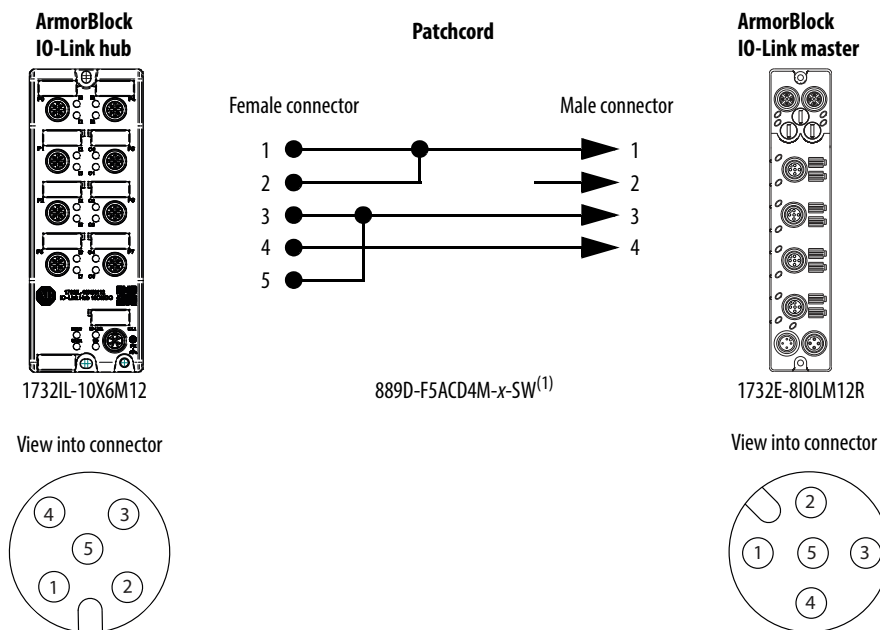

Pin	Value	Description
1	+24V DC (L+)	Supply voltage from IO-Link master
2	+24V DC (2L+)	Additional supply voltage
3	GND (L-)	Reference potential to L+
4	C/Q (IO-Link)	IO-Link data channel
5	GND (2L-)	Reference potential for additional supply voltage

Pin	Description
1 ⁽²⁾	Sensor source voltage
2	IO-Link, input/output B
3	Return
4	IO-Link, input/output A
5	PE

(1) x represents the length of cable in meters (1, 2, 5, 10).

(2) SSV (Pin 1) of IO-Link master supports a maximum of 500 mA per channel/1 A per port.

Figure 9 - Example of Wiring from ArmorBlock IO-Link Master to ArmorBlock IO-Link Hub with Additional Power Supply

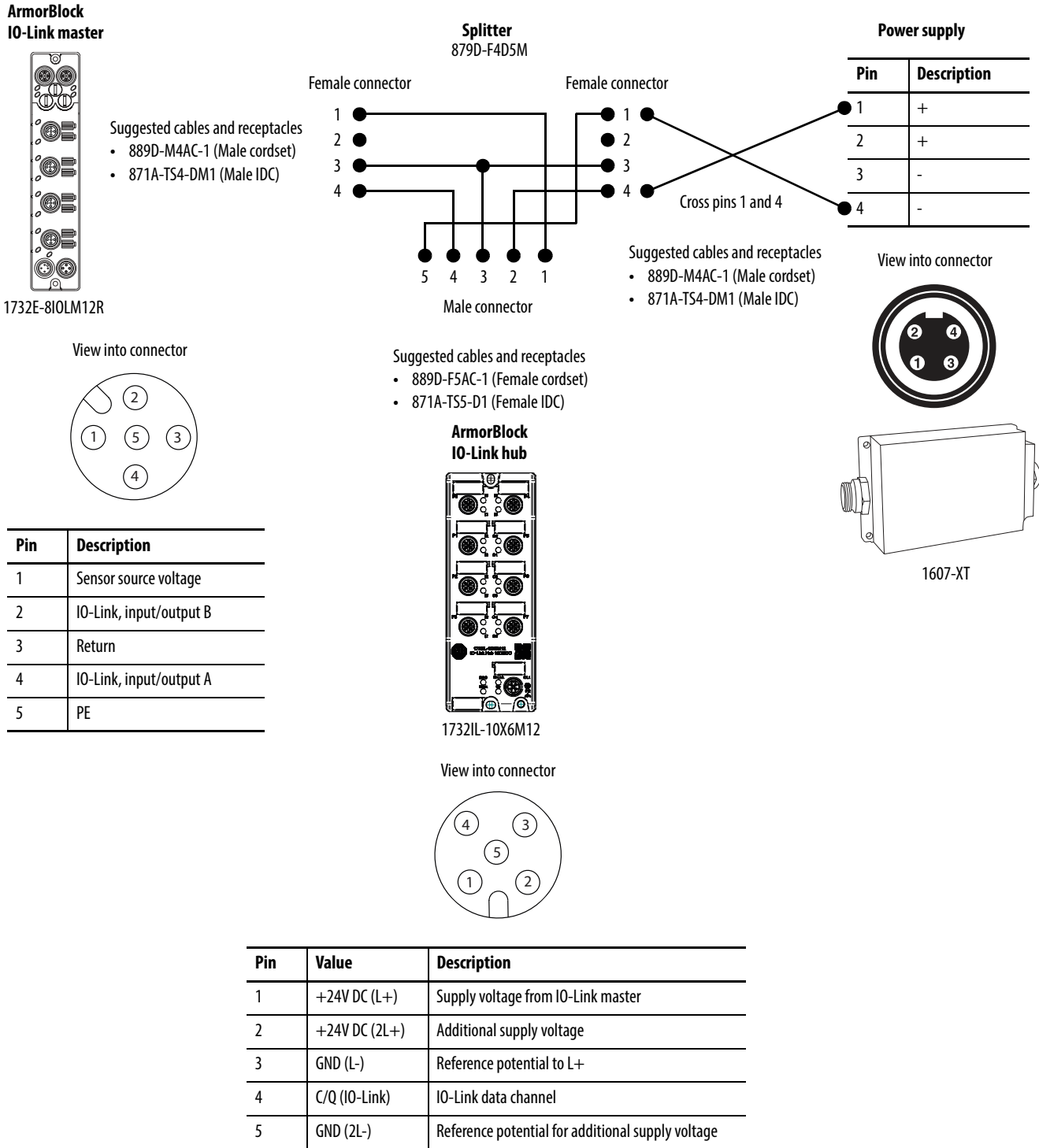
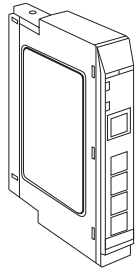

Figure 10 - Example of Wiring from POINT I/O IO-Link Master to ArmorBlock IO-Link Hub

**POINT I/O
IO-Link master**



1734-4IOL

0	Ch 0	1	Ch 1
2	Ch 2	3	Ch 3
4	C	5	C
6	V	7	V

Channel	Common	Voltage
0	4	6
1	5	7
2	4	6
3	5	7

**ArmorBlock
IO-Link hub**

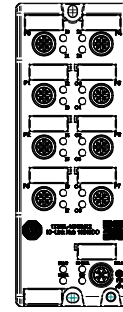

1732IL-10X6M12

View into connector

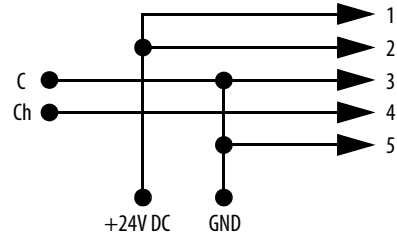
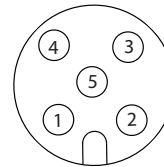

Pin	Value	Description
1	+24V DC (L+)	Supply voltage from IO-Link master
2	+24V DC (2L+)	Additional supply voltage
3	GND (L-)	Reference potential to L+
4	C/Q (IO-Link)	IO-Link data channel
5	GND (2L-)	Reference potential for additional supply voltage

Notes:

Rockwell Automation Support

Use the following resources to access support information.

Technical Support Center	Knowledgebase Articles, How-to Videos, FAQs, Chat, User Forums, and Product Notification Updates.	https://rockwellautomation.custhelp.com/
Local Technical Support Phone Numbers	Locate the phone number for your country.	http://www.rockwellautomation.com/global/support/get-support-now.page
Direct Dial Codes	Find the Direct Dial Code for your product. Use the code to route your call directly to a technical support engineer.	http://www.rockwellautomation.com/global/support/direct-dial.page
Literature Library	Installation Instructions, Manuals, Brochures, and Technical Data.	http://www.rockwellautomation.com/global/literature-library/overview.page
Product Compatibility and Download Center (PCDC)	Get help determining how products interact, check features and capabilities, and find associated firmware.	http://www.rockwellautomation.com/global/support/pcdc.page

Documentation Feedback

Your comments will help us serve your documentation needs better. If you have any suggestions on how to improve this document, complete the How Are We Doing? form at http://literature.rockwellautomation.com/idc/groups/literature/documents/du/ra-du002_-en-e.pdf.

Rockwell Automation maintains current product environmental information on its website at <http://www.rockwellautomation.com/rockwellautomation/about-us/sustainability-ethics/product-environmental-compliance.page>.

Allen-Bradley, ArmorBlock, ControlLogix, Logix 5000, POINT I/O, Rockwell Automation, Rockwell Software, RSLogix 5000, Stratix, Studio 5000, Studio 5000 Logix Designer, and TechConnect are trademarks of Rockwell Automation, Inc. CIP is a trademark of ODVA, Inc. Trademarks not belonging to Rockwell Automation are property of their respective companies.

Rockwell Otomasyon Ticaret A.Ş., Kar Plaza İş Merkezi E Blok Kat:6 34752 İçerenköy, İstanbul, Tel: +90 (216) 5698400

www.rockwellautomation.com

Power, Control and Information Solutions Headquarters

Americas: Rockwell Automation, 1201 South Second Street, Milwaukee, WI 53204-2496 USA, Tel: (1) 414.382.2000, Fax: (1) 414.382.4444
Europe/Middle East/Africa: Rockwell Automation NV, Pegasus Park, De Kleetlaan 12a, 1831 Diegem, Belgium, Tel: (32) 2 663 0600, Fax: (32) 2 663 0640
Asia Pacific: Rockwell Automation, Level 14, Core F, Cyberport 3, 100 Cyberport Road, Hong Kong, Tel: (852) 2887 4788, Fax: (852) 2508 1846

Publication 1732IL-UM001C-EN-P - September 2019

Supersedes Publication 1732IL-UM001B-EN-P - April 2019

Copyright © 2019 Rockwell Automation, Inc. All rights reserved.