

ROKINON®

SP

10MM F3.5 INSTRUCTION MANUAL



Thank you for purchasing the Rokinon SP 10mm F3.5 Full Frame lens. Its high performance optics and design have been optimized to meet the extreme capabilities of Canon and Nikon state of the art cameras.

ADVANTAGES

- Provides an exceedingly high quality 130° (Full Frame), 104° (Canon APS-C) and 107.3° (Nikon APS-C) super wide-angle view with 50 mega pixel photo and 8K video production capabilities.
- Its advanced optical design of 18 precision glass elements in 11 groups includes three Aspherical, three Extra Low Dispersion, and one High Refractive Index type for excellent control of distortion and aberrations with increased center to edge resolution.
- UMC (Ultra Multi Coating) on all lens surfaces effectively controls ghosting and flare while increasing light transmission and contrast.
- Its all metal construction with an ergonomically designed shape and grip deliver a luxurious look, excellent durability and comfortable use.

BEFORE USING

- Please read this instruction manual and familiarize yourself with the functions of the lens and cautions prior to use.
- The supported functions of this product may vary according to the camera model.

⚠ CAUTIONS

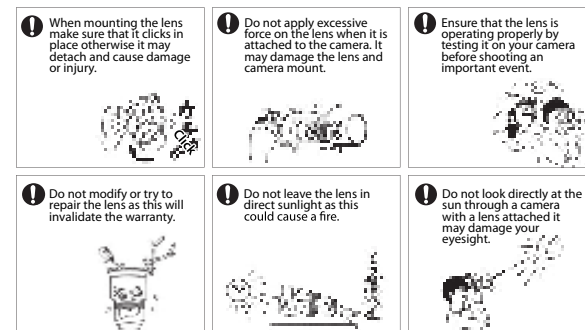

⚠ CAUTIONS (continued)

To maintain your safety and prevent damage to the lens, please fully familiarize yourself with the following:

- Do not look directly at the sun through the lens as it may seriously impair your vision.
- Do not to apply excessive force when attaching the lens to the camera as it may cause damage to the lens or your camera.
- The lens is a precision optical product, so dropping or excessive impact may cause product failure.
- Attach or detach the lens only while the camera is turned off.
- Be careful not to touch or contaminate the contacts on the mount as it can adversely affect communication with the camera.
- Protect the lens from water, high humidity, excessive heat and cold.
- Always store the lens with the lens cap on in a dry and well ventilated location out of direct sunlight. Direct sunlight passing through the lens could become concentrated enough to cause a fire.
- Avoid subjecting the lens to drastic temperature changes such as moving from a very cold outdoors location to a warm indoors location. This can cause moisture in the air to condense inside or on the outside of the lens and lead to failure or mold production. Before taking the lens indoors from a cold outdoors location, put the lens in a plastic bag or sealed camera bag and remove it only when the lens has warmed up to room temperature.

ATTACHING THE LENS

- Remove the rear lens cap and the camera body cap.
- For Canon EF mount, align the red dot on the lens mount (white focusing scale line for Nikon mount) with the index mark on the lens mount of the camera.
- Do not press the lens release button on the camera when mounting the lens.
- For Canon EF mount, insert the lens into the camera mount and rotate it clockwise (counterclockwise for Nikon mount) until it “clicks” and locks in place. Do not insert the lens at an angle.
- Remove the front lens cap when you are ready to shoot.

DETACHING THE LENS

- Attach the front lens cap.
- For Canon EF mount, while holding down the lens release button on the camera body, rotate the lens counterclockwise (clockwise for Nikon mount) until it stops and separate the lens from the body.
- Attach the rear lens cap.

FOCUSING

Please note: It can be difficult to achieve optimum focus using the unaided eye when focusing an extreme wide angle lens such as a 10mm. Check your camera's instruction book for manual focusing methods and focusing aids including Focus Confirmation and Focus Magnification.

- Set the Focus Mode of your camera to “MF” (Manual Focus). Adjust the focus by rotating the focusing ring on the lens until the focus confirmation indicator in your viewfinder confirms focus or the subject looks the sharpest.
- Another focusing option is to use the magnifying feature of “Live View”. Utilizing the highest magnification available, adjust the focus by rotating the focusing ring until the image on your LCD screen looks the sharpest.

PARTS

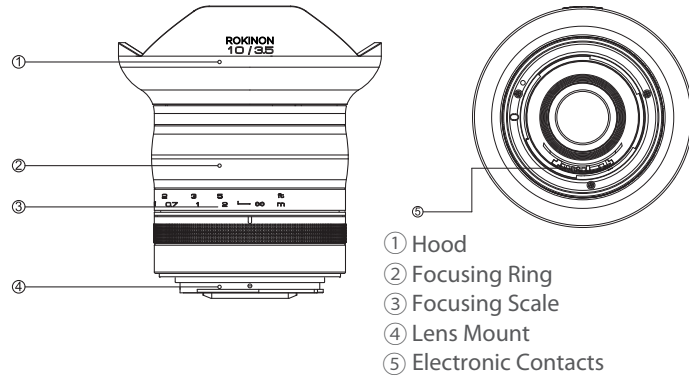

INCLUDED COMPONENTS

- Front lens cap
- Rear lens cap
- Warranty
- Soft lens pouch
- Instruction manual

CLEANING

Please note: It is extremely important before cleaning to dust off the lens surface using a lens blower or a soft brush to remove any foreign particles or grit that could scratch the lens.

- Using a clean microfiber lens cloth, gently wipe the lens in a circular motion from the center outwards towards the edges of the glass.
- If stubborn spots remain, put only one or two small drops of ethanol or reputable lens cleaner on the microfiber cloth and repeat the circular cleaning process. **DO NOT USE AN ORGANIC SOLVENT SUCH AS PAINT THINNER, ALCOHOL, OR BENZENE.**

PRODUCT SPECIFICATIONS

MODEL		SP 10mm F3.5	
MOUNT		Canon EF	Nikon F
ANGLE OF VIEW	FULL FRAME	130.0°	130.0°
	APS-C	104.0°	107.3°
MAXIMUM DIAMETER X LENGTH		3.74" x 3.86" (95mm x 98.1mm)	3.74" x 3.76" (95mm x 95.6mm)
WEIGHT		25.78oz (731g)	25.89oz (734g)
APERTURE RANGE		F3.5-22	
OPTICAL CONSTRUCTION		18 elements in 11 groups (including 3 Aspherical, 3 Extra Low Dispersion and 1 High Refractive Index)	
MINIMUM FOCUSING DISTANCE*		10.2" (0.26m)	
MAXIMUM SHOOTING MAGNIFICATION		x 0.07	
NUMBER OF APERTURE BLADES		7	

*The minimum focus is the distance from the image sensor to the object.

CONTACT

Elite Brands Inc.
Rokinon Division
New York, NY 10005

Toll Free: 800.441.1100
Phone: 212.947.7100
support@rokinon.com

rokinon.com
facebook.com/rokinonlenses
instagram.com/rokinon

ROKINON® is a registered trademark of Elite Brands Inc.
©2019, Elite Brands Inc., New York, NY 10005

The product specifications and design are subject to change without notice.

NOTES

NOTES