

FemtoStepper

100fs Resolution Phase Stepper



User Manual

Contents

1.	Introduction	3
1.1.	Frequency Adjustment	3
1.2.	Phase Adjustment.....	4
1.3.	Microprocessor Control and PPS (Pulse per Second) Facility	4
2.	Installation	5
2.1.	Safety	5
2.2.	Environmental Responsibility	5
2.3.	Unpacking	5
2.4.	Electrical & Indicator Interfaces.....	6
2.5.	Connections.....	6
2.6.	Recommendations.....	6
2.7.	System Power-Up	7
3.	System Control.....	7
4.	RS232 Commands	9
4.1.	Identification	9
4.2.	Serial Number	9
4.3.	Status	9
4.4.	Single Phase Step	10
4.5.	Packet Phase Step	10
4.6.	Actual Phase Adjustment	10
4.7.	Frequency Offset	11
4.8.	Actual Frequency Offset.....	11
4.9.	Frequency Drift.....	12
4.10.	Pulse Per Second Alignment.....	12
4.11.	PPSOUT Delay	12
4.12.	Information Every Second	13
5.	Mechanical	14
6.	Safran Technical Support.....	15

1. Introduction

The FemtoStepper provides a highly stable 10MHz, available on four outputs, that is adjustable in phase and frequency with an extremely high resolution. In addition to the 10MHz outputs, the micro-stepper provides a one pulse per second (1PPS) available on four outputs generated from the 10MHz output.

The FemtoStepper provides a 10MHz signal that is derived from a high performance, ultra low phase noise crystal oscillator which is phase locked to an external 10MHz reference input. It allows to adjust the outputs in phase and frequency without disturbing the reference signal source and precautions are taken in order to minimize the added noise.

The design is based on a double heterodyne architecture where a first structure is used for positive phase / frequency adjustment and the second structure for negative adjustment.

The device is controlled remotely through an RS-232 serial link, which provides a prompt with a defined list of commands. All commands are parsed for correct syntax and operational range prior to execution. Commands that contain errors are rejected.

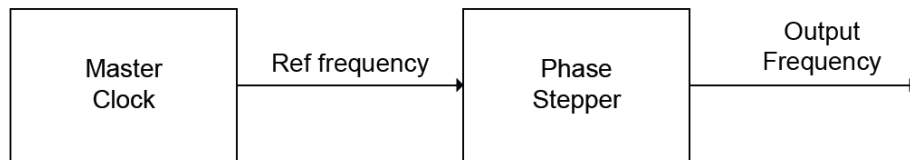

Figure 1: Application diagram

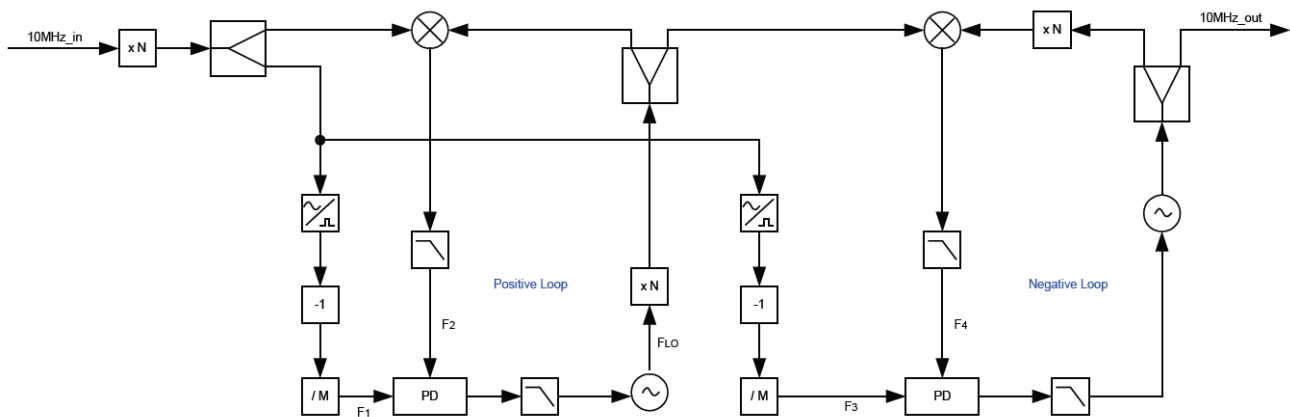

Figure 2: Block diagram

1.1. Frequency Adjustment

The frequency offset is applied to the output 10MHz OCXO through the double heterodyne structure in order to increase the resolution.

$$F_{out} = F_{in} + \frac{\Delta f}{G}$$

Where:

G: Heterodyne Gain of 106.

Δf is managed by the microprocessor.

$$F_{out} = \frac{F_{in}}{1 - \frac{N}{10^{17}}}$$

Where:

N: Frequency offset by 10-17 steps.

The frequency offset is always the absolute value from the 10MHz input.

The output range is limited nearly ±10⁻⁹. (±9.9999999 × 10⁻¹⁰)

1.2. Phase Adjustment

The output phase is adjustable with 0.1 picosecond resolution over a maximum range of ±50ns in order to cover an entire period of the 10MHz output signal. The phase adjustment is performed under microprocessor control.

1.3. Microprocessor Control and PPS (Pulse per Second) Facility

The microprocessor is controlling the functions. It is clocked by the 10 MHz_{out}. A division by 1e+7 is made, providing the PPS_{out}. The PPS_{out} can be aligned to a reference PPS_{ref} within +/- 200 ns when the command AL1 is issued.

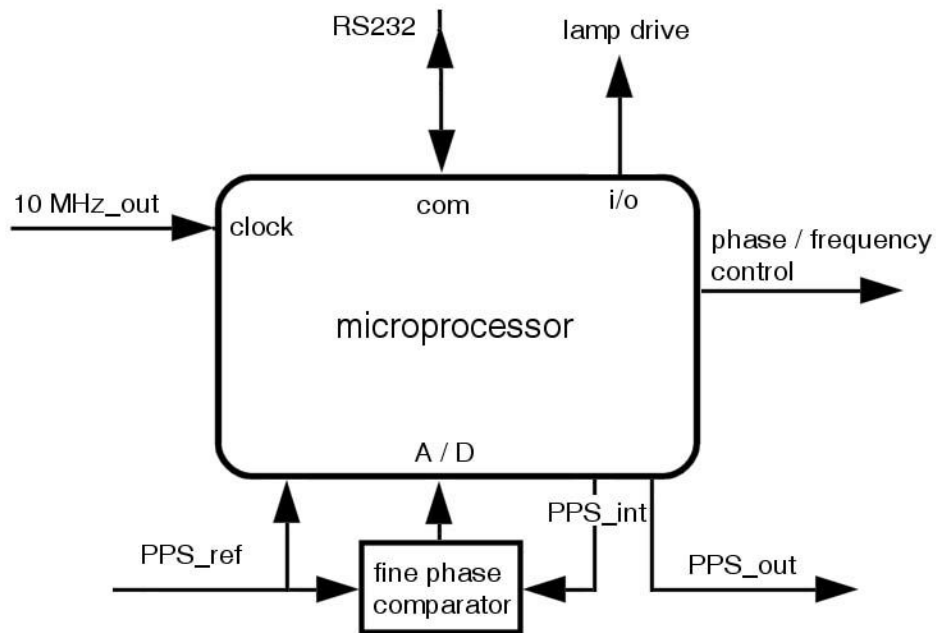

Figure 3: The microprocessor and its surrounding

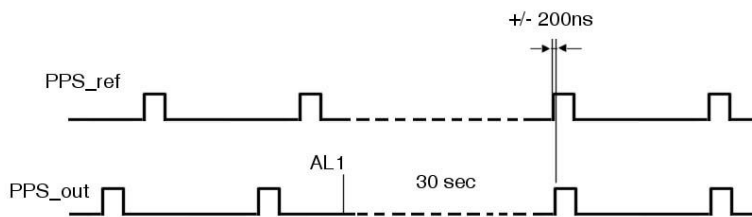

Figure 4: The PPS_{out} can be aligned to the PPS_{ref}

2. Installation

2.1. Safety

Warning: Use proper ESD precautions

Caution: Ensure that all cables are properly connected

Handling the product in reasonably foreseeable conditions do not cause any risk for human health, exposure to the SVHC (substances of very high concern) would require grinding the component up.

2.2. Environmental Responsibility

- The equipment contains materials, which can be either re-used or recycled.
- Do not deposit the equipment as unsorted municipal waste. Leave it at an authorized local WEEE collection point or return to Safran Trusted 4D to ensure proper disposal.
- To return the appliance:
 - Submit a support ticket at aftersales.clocks@nav-timing.safrangroup.com and request an RMA.
 - We will contact you for more information and/or with shipment process details.

2.3. Unpacking

Unpack and carefully inspect the unit. Check for physical damage. If physical damage is observed, then immediately contact Safran Trusted 4D.

Unit Supply:

- 1 FemtoStepper Rack 19"/2U
- 1 Cable SUB-D 9 pins male/female
- 1 Euro power cable
- 2 Brackets for rack mount (only with standard version)
- 1 Connector for Backup DL power supply

2.4. Electrical & Indicator Interfaces

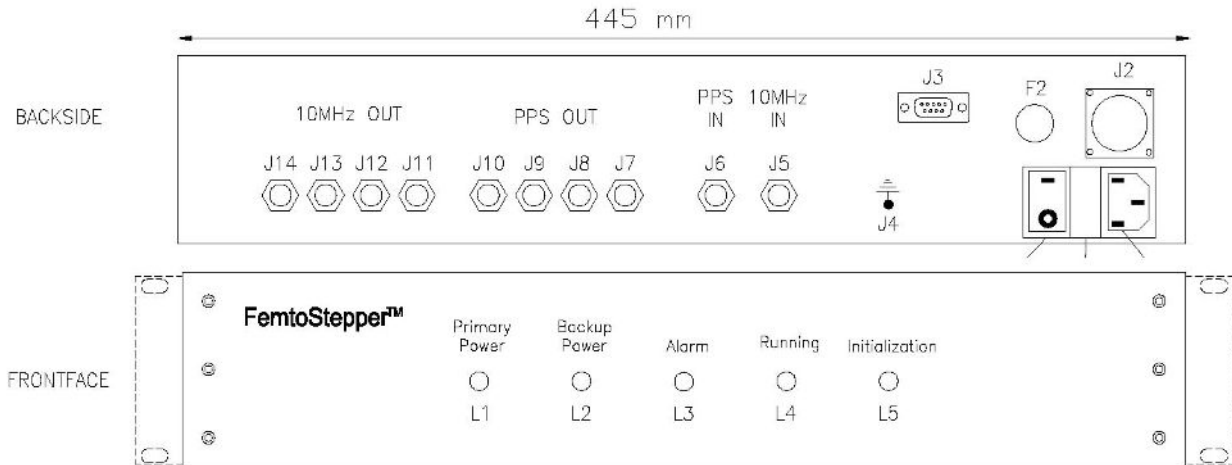

Figure 5: Interfaces

N°	In/Out	Designation	Type
J1	In	230VAC primary power	Schurter KM00.1105.11
J2	In	+24VDC backup power	Jaeger 5306004006
J3	In/Out	COM Interface	Sub-D-9P-FEM
J4	-	Ground connection	Screw M4
J5	In	10 MHz reference signal	SMA
J6	In	PPS reference signal	SMA
J7-J10	Out	4x PPS output	SMA
J11-J14	Out	4x 10MHz output	SMA
S1	-	On/Off switch	
F1	-	Primary power supply fuse - T 3,15A	
F2	-	Backup power supply fuse - T 1,6A	
L1	-	Primary power indicator	Green
L2	-	Backup power indicator	Green
L3	-	Alarm indicator	Red
L4	-	Running indicator	Green
L5	-	Initialization indicator	Yellow

Table 1: Interfaces

	Pin	Designation
J1	In	230VAC primary power
J2	In	+24VDC backup power
J3	In/Out	COM Interface
J4	-	Ground connection

Table 2: Backup Power Connector

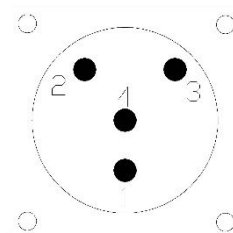

2.5. Connections

- Connect the 10MHz input reference to the FemtoStepper unit (J5).
- Connect, if PPS functionality is desired, the PPSref signal (J6).
- Connect the male SUB-D-9 to the unit (J3) and female SUB-D-9 to the computer.
- Connect the primary power cable (230VAC) to the unit (J1).
- Connect the backup power cable (+24VDC) to the unit (J2).
- Optionally, connect the device to ground (J4).
- Switch on the unit (S1).

2.6. Recommendations

- Warm-up FemtoStepper several hours before to start any applications.
- To reduce warm-up time, keep FemtoStepper powered-up at all times even when an input reference signal is not available.
- To ensure a continuous operation, connect a uninterruptable backup 24V power source.

- Avoid locations of the unit with variable air flow and temperature changes.
- Avoid to place FemtoStepper close to vibration environment and high magnetic fields changes.

2.7. System Power-Up

- Switch on the unit (S1).
- If the primary power is connected, L1 indicator is green.
- If the backup power is connected, L2 indicator is green.
- The alarm indicator (L3) is red while warming-up.
- During the first five seconds, the microprocessor is performing an initialization. At the end of the initialization sequence, L5 switches off.
- After approximately fifteen minutes, the alarm (L3) indicator have to switch off. If still red, check if an input reference is connected (J5).
- When ready to operate the running indicator (L4) becomes green.
- When a frequency offset is applied, the running indicator (L4) is blinking.

3. System Control

The device is controlled remotely through an RS-232 serial link, which provides a prompt with a defined list of commands. All commands are parsed for correct syntax and operational range prior to execution. Commands that contain errors are rejected.

The RS232 protocol is:

- 9600 bits/s
- 8 data bits
- No parity
- 1 stop bit
- No handshake

FemtoStepper accepts the following ASCII commands: Data is in decimal ASCII code.

Command Name	Syntax Command	Data Field (if any)	Response Syntax	Response Data (if any)
Identification	ID<CR><LF>	-	TNTMPS-aaa/rr/s.ss<CR><LF>	aaa: 001 rr: revision number s.ss: software version
Serial Number	SN<CR><LF>	-	xxxxxx<CR><LF>	xxxxxx : 6 digits serial nbr
Status	ST<CR><LF>	-	yyxx<CR><LF>	yy : always 00 (for future use) xx : HEX ASCII Bit signification : Bit 7 :- Bit 6 :backup power active Bit 5 :primary power active Bit 4 :frequency drift not 0 Bit 3 :frequency offset not 0 Bit 2 :stepping activity Bit 1 : OOL - Bit 0 : OOL +
Single Phase Step	PSs<CR><KF>	s= + : Positive Step s= - : Negative Step	s<CR><LF>	s: signe s= + : Positive Step s= - : Negative Step
Packet Phase Step	PSsdddddd<CR><LF>	s=+ : Positive Packet Step s=- : Negative Packet Step dddddd: number	sdddddd<CR><LF>	s:signe s=+ : Positive Packet Step s=- : Negative Packet Step dddddd: value
Actual Phase Offset	PH<CR><LF>	-	sdddddd<CR><LF>	s:signe s=+ : Positive Packet Step s=- : Negative Packet Step dddddd: value From 000000 To 500000
Frequency Offset	FAsddddddd<CR><LF>	s= + : Positive offset s= - : Negative offset ddddddd: number	sddddddd<CR><LF>	s= + : Positive offset s= - : Negative offset ddddddd: value
Actual Frequency Offset	FR<CR><LF>	-	sddddddd<CR><LF>	s= + : Positive offset s= - : Negative offset ddddddd: value
Frequency Drift	FDsdddd<CR><LF>	s= + : Positive drift s= - : Negative drift	sdddd<CR><LF>	s= + : Positive drift s= - : Negative drift dddd : value in 1E-17/day frequency drift
Align PPSOUT to PPSREF	ALd<CR><LF>	d= 1 : align d= ? : alignment status	d<CR><LF>	d= 0: ready for alignment d= 1: alignment in progress d= 2 : no PPSREF
Set PPSOUT delay (rounded to 200ns)	DEddddddd<CR><LF>	ddddddd=delay in ns. Max 999999800 ????????? :interrogation	ddddddd=delay in ns. Max 999999800 ????????? :interrogation	ddddddd=delay in ns. Min 000000000 Max 999999800
Send Information Every Second	BTx<CR><LF>	x= 0 : Stop to send x= 3 : PPSRef position x= 5 : Status	x= 3 : aaaaaaaaa sbbb<CR><LF> x= 5 : yyxx<CR><LF>	aaaaaaaa= PPSOUT vs PPSREF delay in ns. sbbb= fine phase comparator value in approx. ns yyxx= see ST command

Table 3: Serial commands summary

4. RS232 Commands

4.1. Identification

ID<CR>[<LF>] : Identification

Answer : TNTMPS-aaa/rr/s.ss<CR><LF>
 aaa : 001
 rr : revision number
 s.ss : software version

Example : ID<CR> answers TNTMPS-001/01/1.00<CR><LF>

4.2. Serial Number

SN<CR>[<LF>]: Serial number

Answer: xxxxxx<CR><LF>
 Xxxxxx : 6 digits serial number

Example: SN<CR> answers 000015<CR><LF>

4.3. Status

ST<CR>[<LF>] : Status

Answer : yyxx<CR><LF>
 yy : always 00 (reserved for future use)
 xx : HEX ASCII status :
 bit 7 :--
 bit 6 : backup power active
 bit 5 : primary power active
 bit 4 : frequency drift not 0
 bit 3 : frequency offset not 0
 bit 2 : stepping activity
 bit 1 : OOL negative loop
 bit 0 : OOL positive loop

Example : ST<CR> answers 0068<CR><LF>
 (backup and primary power active, frequency offset applied, no frequency drift, system locked)

Note : BT5<CR> send status once per second in the same format.

4.4. Single Phase Step

PSs<CR>[<LF>] : Single phase step

s = +: 1 positive phase step of 10-13 second
-: 1 negative phase step of 10-13 second

Answer : s<CR><LF>
s : sign of the single phase step

Example : PS+<CR> answers +<CR><LF>

Note : Phase adjustment are not absolute value.

4.5. Packet Phase Step

PSsdddddd<CR>[<LF>] : Packet phase step

s = +: positive phase adjustment
-: negative phase adjustment

dddddd : phase adjustment in 10-13 second
000000 to 500000
000001 : minimum phase adjustment ($\pm 1 \times 10^{-13}$ s)
500000 : maximum phase adjustment ($\pm 5 \times 10^{-9}$ s)
000000 : no phase adjustment

Answer : sdddddd<CR><LF>
dddddd : phase adjustment value

Example : PS+000100<CR> answers +000100<CR><LF>
(a positive phase adjustment of 10-11 second is asked)

Note : Phase adjustment are instantaneous phase changes and are cumulative with previous phase changes.

4.6. Actual Phase Adjustment

PH<CR>[<LF>] : Actual phase adjustment

Answer : sdddddd<CR><LF>

s = +: positive phase adjustment
-: Negative phase adjustment

dddddd : phase adjustment value in 10-13 second step

Example : PH<CR> answers -000020<CR><LF>
(an total actual negative phase adjustment of 2×10^{-12} second has been applied)

Note : The actual phase is the accumulated phase changes from the starting of the system. A frequency offset different from 0 reset the phase adjustment to 0.

Example : At To the command PS+000002<CR> has been sent,
At T1 the command PS-000007<CR> has been sent,
At T2 the command PS+000009<CR> has been sent,
At T3 the command PH<CR> answers +000004 which corresponds to the total accumulated phase adjustment applied until T3 ($2-7+9=4 \times 10^{-13}$ second).

4.7. Frequency Offset

FAdddddddd<CR>[<LF>] : Frequency offset

s = +: positive frequency offset
 -: Negative frequency offset

ddddddd : frequency offset in 10-17 step
 00000000 to 10000000
 00000001 : minimum frequency offset ($\pm 1 \times 10^{-17}$)
 99999999 : maximum frequency offset ($\pm 9.9999999 \times 10^{-10}$)
 00000000 : no frequency offset

Answer : sddddddd<CR><LF>
 sddddddd : frequency offset value

Example : FA+00010000<CR> answers +00010000<CR><LF>
 (a positive frequency offset of 10-13 relative to input reference frequency is asked)

Note : Frequency offset are absolute value from input reference frequency. A new frequency offset overwrite the previous one.

4.8. Actual Frequency Offset

FR<CR>[<LF>] : Actual frequency offset

Answer : sddddddd<CR><LF>

s = +: positive frequency offset
 -: negative frequency offset

ddddddd : frequency offset in 10-17 step

Example : FR<CR> answers -00100000<CR><LF>
 (a negative frequency offset of 10-12 relative to input reference frequency is applied)

Note : Frequency offset are absolute value from input reference frequency. A new frequency offset overwrite the previous one.

Example : At To the command FA+00600000<CR> has been sent,
 At T1 the command FA-00020000<CR> has been sent,
 At T2 the command FR<CR> answers -00020000 which is the actual frequency offset (it corresponds to the last frequency offset command applied before T2.)

4.9. Frequency Drift

FDsdddd<CR>[<LF>] : Change the frequency during time

s = + : positive frequency drift
- : negative frequency drift

dddd : frequency drift in 1E-17/day
-32768 to +32767
+00000 no drift
????? interrogation

Answer: sdddd : just asked drift or drift actually active

Example: FD?????<CR> answers +00100<CR><LF>. The frequency is increased of 1E-17 every 864 seconds and this value can be read back with the command FR.

4.10. Pulse Per Second Alignment

ALd<CR>[<LF>] : PPSOUT alignment to PPSREF

d = 1 : align
? : interrogation

Answer : d<CR><LF>
0: ready for alignment
1: alignment in progress
2: no PPSREF

Example : AL1<CR> answers 1<CR><LF>

Notes: While the command is in progress, an internal PPSLOCAL is aligned to PPSREF. This can take up to 30 seconds.
The alignment is done within +/- 200 ns.
After an alignment DE???????? answers 000000000<CR><LF>
This command has no influence on the 10 MHz output.

4.11. PPSOUT Delay

DEddddddddd<CR>[<LF>] :Set a PPSOUT delay

ddddddddd : delay in ns
000000000 to 999999800
000000000 : no delay
000000200 : minimum delay
999999800 : maximum delay
????????? : interrogation

Answer : dddddddd<CR><LF>
ddddddd : just asked delay

Example : DE????????<CR> answers 000000000<CR><LF>

Notes : After power on / Reset, the PPSOUT position is random.
After the command AL1, the PPSOUT is aligned to PPSREF and the delay is settled to 0.
This command has no influence on the 10 MHz output.

4.12. Information Every Second

BTx<CR>[<LF>]: send information once per second on the serial port

x= 0 : stop to send

Answer : none

x = 3 : PPSOUT vs PPSREF position

Answer : aaaaaaaaa sbbb<CR><LF> once per second
 aaaaaaaaa : raw PPSOUT vs PPSREF position in ns, rounded to 200 ns steps
 000000000 : PPSOUT aligned to PPSREF
 000000200 : minimum value
 999999800 : maximum value
 ?????????? : no PPSREF

sbbb : s : sign +/- ; bbb : analog fine PPS comparator value in approximately ns. PPSLOCAL vs PPSREF.
 +000 : PPSLOCAL and PPSREF are perfectly aligned.
 -500 : lowest value
 +500 : highest value

Remark : the command AL1<CR><LF> must be sent first to bring the PPSLOCAL in the PPS phase comparator working range.

x = 5 : Status

Answer : yyxx<CR><LF> once per second
 See Status command for details

5. Mechanical

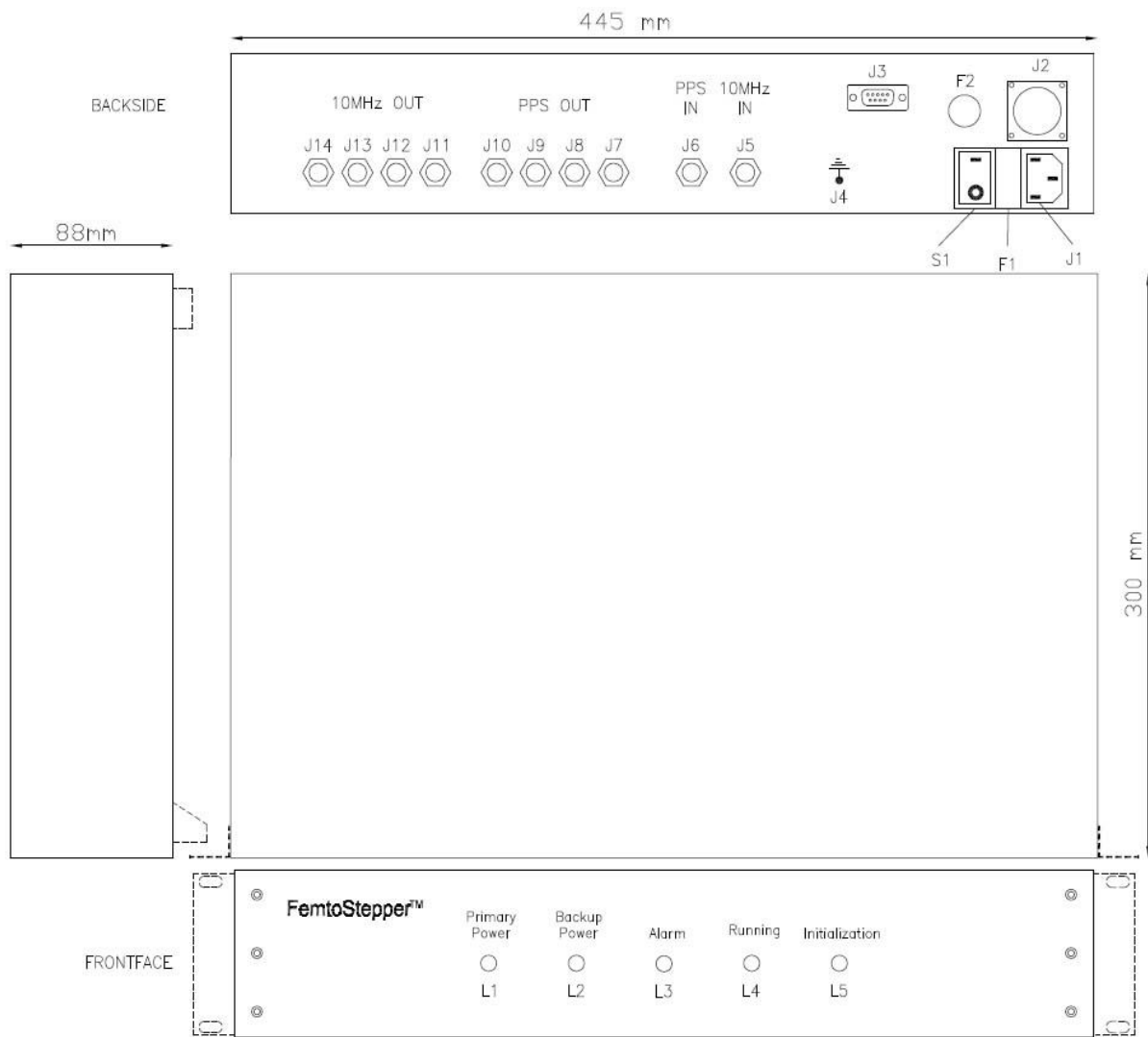

Figure 6

6. Safran Technical Support

For technical support, you can visit <https://safran-navigation-timing.com/support-hub/> to submit a support request.

For product specifications and additional documentation, visit our product page at <https://safran-navigation-timing.com/product/femto stepper/>

Information furnished by Safran is believed to be accurate and reliable. However, no responsibility is assumed by Safran for its use, nor for any infringements of patents or other rights of third parties that may result from its use. Safran reserves the right to make changes without further notice to any products herein. Safran makes no warranty, representation or guarantee regarding the suitability of its products for any particular purpose, nor does Safran assume any liability arising out of the application or use of any product or circuit, and specifically disclaims any and all liability, including without limitation consequential or incidental damages. No license is granted by implication or otherwise under any patent or patent rights of Safran. Trademarks and registered trademarks are the property of their respective owners. Safran products are not intended for any application in which the failure of the Safran product could create a situation where personal injury or death may occur. Should Buyer purchase or use Safran products for any such unintended or unauthorized application, Buyer shall indemnify and hold Safran and its officers, employees, subsidiaries, affiliates, and distributors harmless against all claims, costs, damages, and expenses, and reasonable legal fees arising out of, directly or indirectly, any claim of personal injury or death associated with such unintended or unauthorized use, even if such claim alleges that Safran was negligent regarding the design or manufacture of the part.