

Thank you for purchasing a Sealey product. Manufactured to a high standard, this product will, if used according to these instructions, and properly maintained, give you years of trouble free performance.

IMPORTANT: PLEASE READ THESE INSTRUCTIONS CAREFULLY. NOTE THE SAFE OPERATIONAL REQUIREMENTS, WARNINGS & CAUTIONS. USE THE PRODUCT CORRECTLY AND WITH CARE FOR THE PURPOSE FOR WHICH IT IS INTENDED. FAILURE TO DO SO MAY CAUSE DAMAGE AND/OR PERSONAL INJURY AND WILL INVALIDATE THE WARRANTY. KEEP THESE INSTRUCTIONS SAFE FOR FUTURE USE.



Refer to instruction manual

1. SAFETY

- WARNING!** Ensure Health & Safety, local authority, and general workshop practice regulations are adhered to when using this bench.
- ✓ Locate the bench in a suitable work area.
- ✓ Keep the work area clean, uncluttered and ensure there is adequate lighting.
- WARNING!** Use the bench on level and solid ground, preferably concrete.
- ✓ Keep the bench clean and tidy in accordance with good workshop practice.
- ✓ Keep children and unauthorised persons away from the work area.
- ✗ **DO NOT** use the bench for any purpose other than for which it is designed.
- ✗ **DO NOT** undertake work on the bench without the workpiece being adequately secured.
- ✗ **DO NOT** use the bench outdoors.
- ✗ **DO NOT** clean the bench with any solvents which may damage the surface or the protective coating on the worktop.
- ✗ **DO NOT** get the bench wet or use in damp or wet locations or areas where there is condensation.

2. INTRODUCTION

Made from Rubber Wood. Features tool well, shelf, 4 tool drawers, front vice, four metal bench stops and four wooden board jacks. Supplied with 4 Wooden Pegs and 4 Anvil Pegs.

3. SPECIFICATION

Model No: AP1640
 Overall Size (W x D x H): 1520mm x 620mm x 820mm
 Worktop: 1520 x 500mm

Tool Well: 1110 x 410mm
 Drawer(x4): 460 x 390 x 80mm
 Vice (x1): 280mm wide x 180mm opening

4. CONTENTS

Part no.	Description	Quantity
1	Table top	1
2	Shelf	1
3	Cross brace	2
4	Leg	2
5	Vice	1
6	Screw 60mm	4
7	Bolt 90mm	4
8	Connecting nut	4
9	Hex wrench 50mm	1
10	Wood peg	4
11	Anvil peg	4
12	Washer	8
13	Screw 30mm	32
14	Screw 35mm	6
15	Sliding partition	1
16	Lower support	2
17	Drawer front panel (P1)	4
18	Drawer back panel (P2)	4
19	Drawer panel (P3)	4

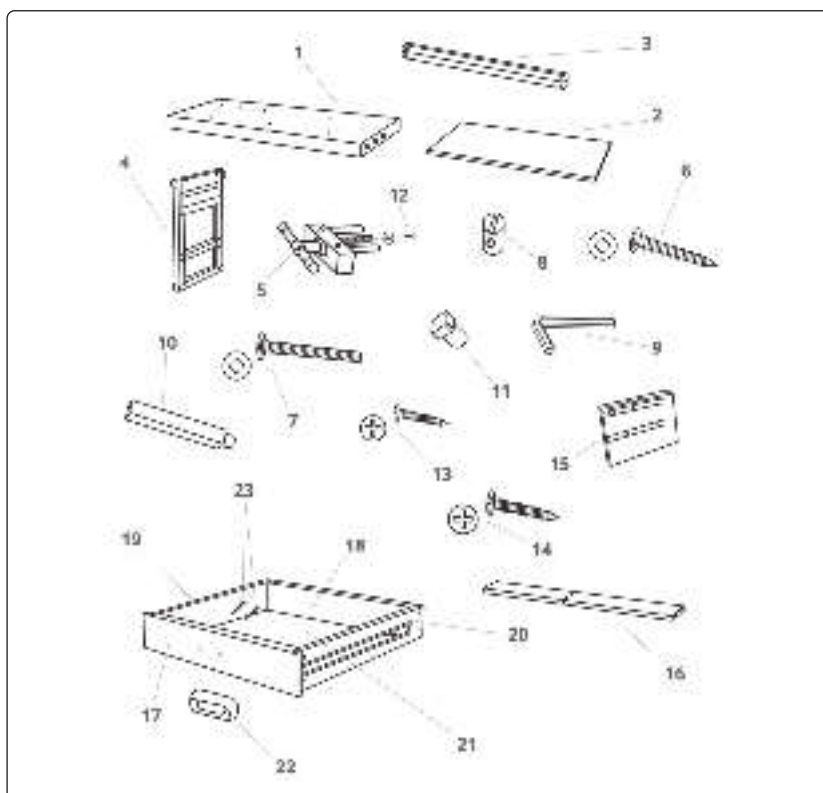

20	Drawer slot panel (P4)	4
21	Drawer bottom (P5)	4
22	Drawer handle	4
23	Drawer screw (40mm)	8

5. ASSEMBLY

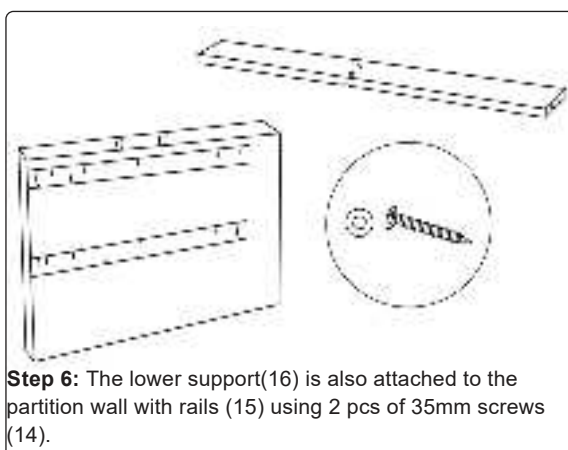
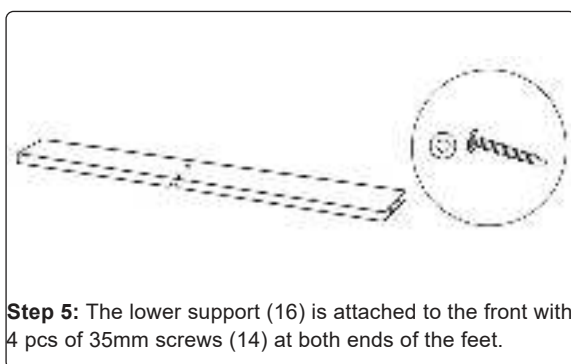
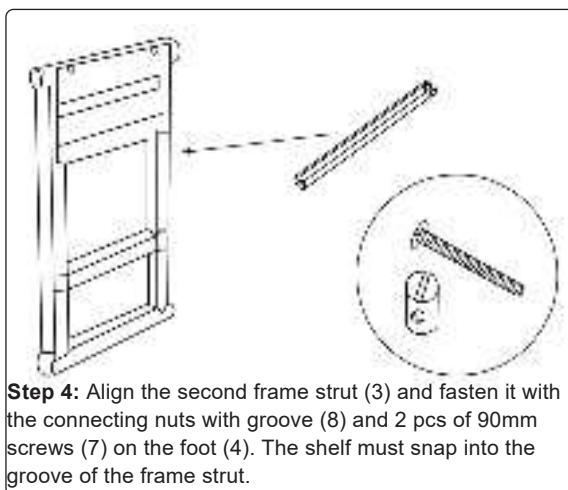
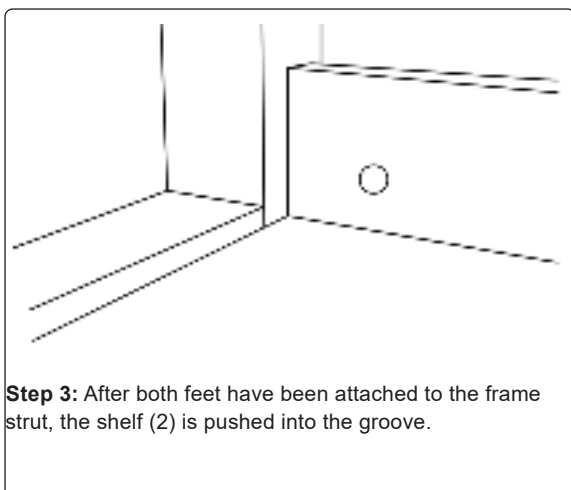
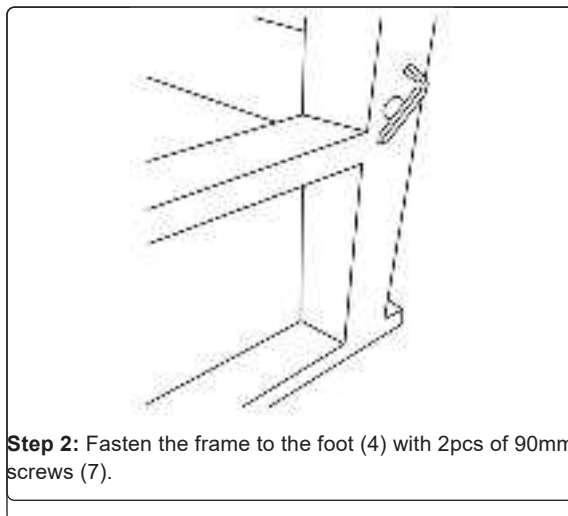
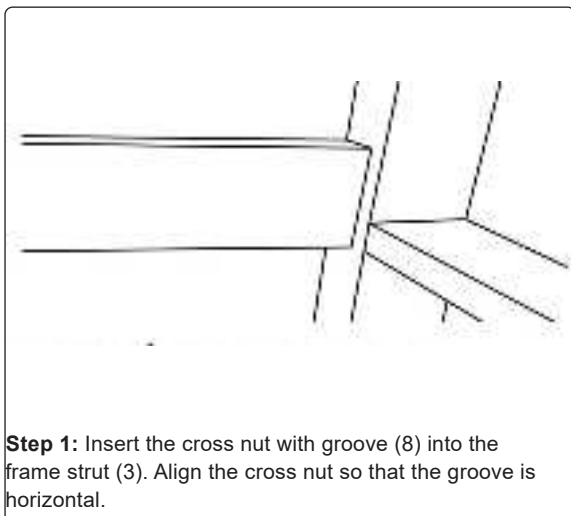

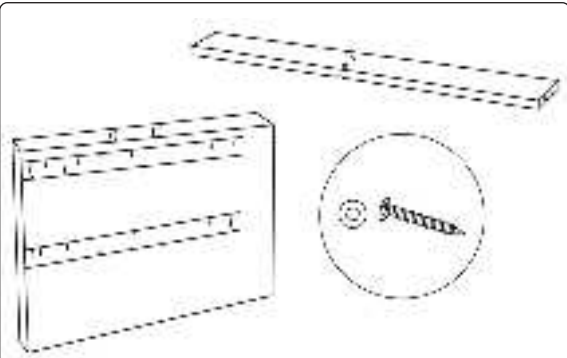

Step 7: The legs are then attached to the worktop with 4 pcs of 60mm screws (6), 2 pcs per leg.

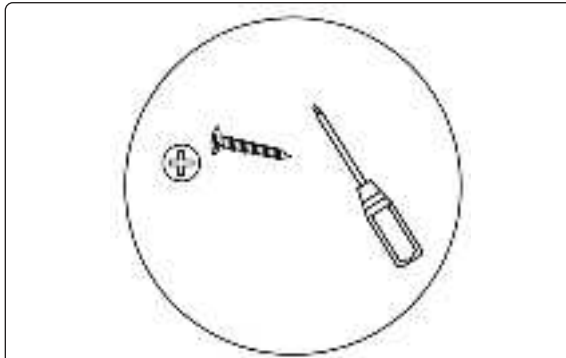

Step 8: The partition is also attached to the frame with 2 pcs of 35mm screws (14). **WARNING!** there are no pre drilled holes.

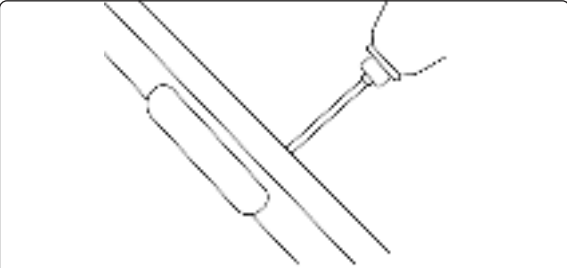

Step 9: Attach handles (22) to the front of the drawer (17) with 8 pcs of 40mm drawer screws (23), 2 pcs per drawer.

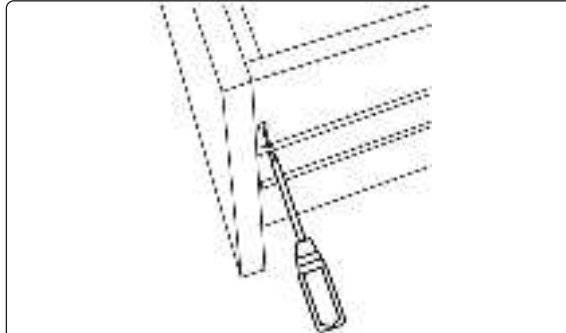

Step10: The two side parts of the drawer (19 & 20) are attached to the front of the drawer with 2 pcs of 30mm screws (13) per side, 4 pcs per drawer.

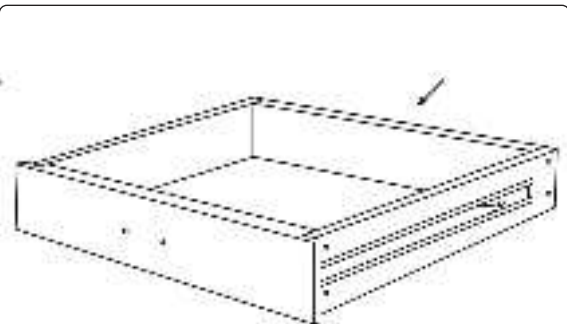

Step11: The back of the drawer (18) is attached to the two side parts by using 4 pcs of 30mm screws (13), 2 pcs per side. Then insert the bottom of the drawer.

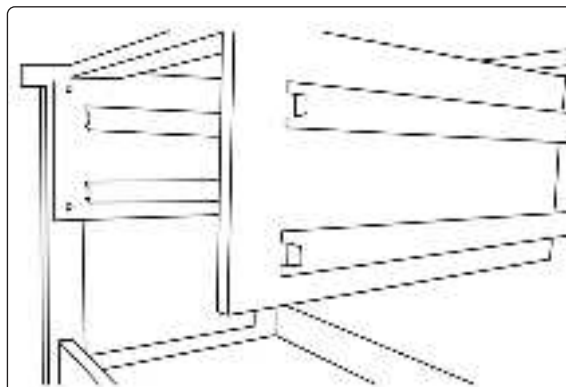

Step12: After installing the drawers, check whether the inner tracks of the drawer pull outs are pushed all the way forward if not, then push all the way forward.

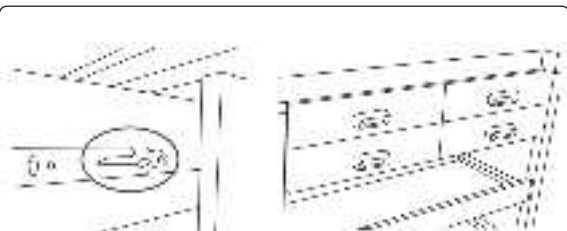

Step13: When inserting the drawers, make sure the runner clip is facing forwards see picture, then slide the drawers into the guides.

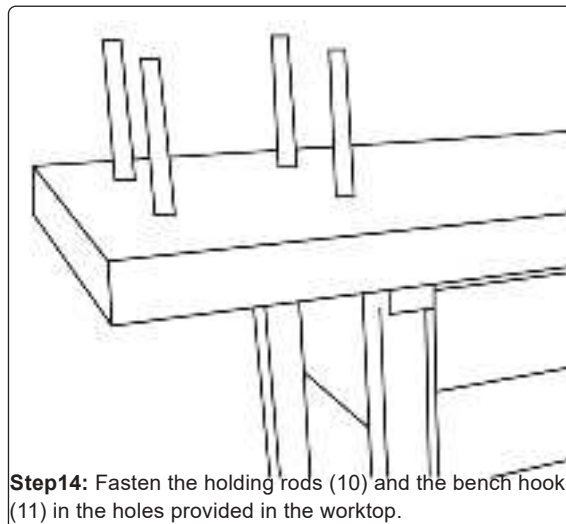

Step14: Fasten the holding rods (10) and the bench hooks (11) in the holes provided in the worktop.



ENVIRONMENT PROTECTION

Recycle unwanted materials instead of disposing of them as waste. All tools, accessories and packaging should be sorted, taken to a recycling centre and disposed of in a manner which is compatible with the environment. When the product becomes completely unserviceable and requires disposal, drain any fluids (if applicable) into approved containers and dispose of the product and fluids according to local regulations.

Note: It is our policy to continually improve products and as such we reserve the right to alter data, specifications and component parts without prior notice.

Important: No Liability is accepted for incorrect use of this product.

Warranty: Guarantee is 12 months from purchase date, proof of which is required for any claim.

Sealey Group, Kempson Way, Suffolk Business Park, Bury St Edmunds, Suffolk. IP32 7AR



01284 757500



01284 703534



sales@sealey.co.uk



www.sealey.co.uk