



# 2 TONNE LOW ENTRY SHORT CHASSIS TROLLEY JACK

MODEL NO: 1050CXLE.V3

Thank you for purchasing a Sealey product. Manufactured to a high standard, this product will, if used according to these instructions, and properly maintained, give you years of trouble free performance.



Refer to instruction manual



Wear safety footwear

## 1. SAFETY

- ✓ Ensure the jack is in sound condition and good working order. Take action for immediate repair or replacement of damaged parts.
- ✓ Use genuine parts only. The use of improper parts may be dangerous and will invalidate the warranty.
- ✓ Locate the jack in a suitable, well lit working area. Keep working area clean and tidy and free from unrelated materials.
- ✓ Use jack on level/solid ground, preferably concrete. Avoid tarmac as jack may sink in.
- ✓ Place wedges under wheels of vehicle, but ensure the jack wheels are free to move and that there are no obstructions.
- ✓ Ensure the vehicle handbrake is engaged, engine is switched off and transmission is in gear (or "PARK" if automatic).
- ✓ Ensure minimum distance of 0.5m between vehicle and static objects such as doors, walls, etc., to allow for vehicle tilting.
- ✓

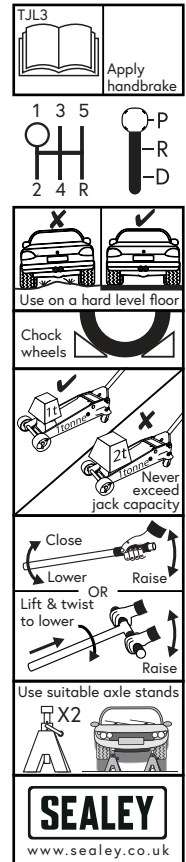

## 4. ASSEMBLY

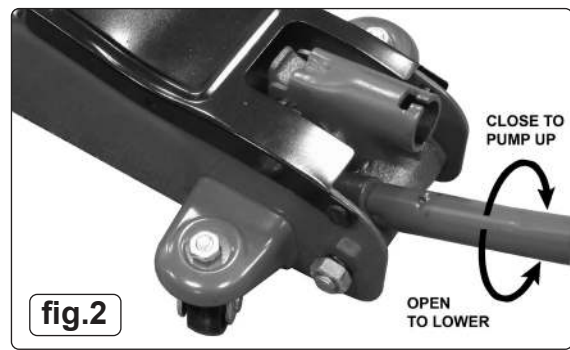
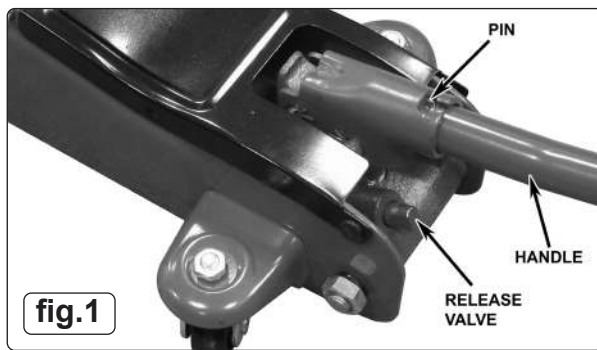

- 4.1. To pump, place the handle into the jacking socket and turn it to engage the external pin as shown in fig.1.
- 4.2. To operate the release valve engage the cross pin in the open end of the handle with the slot in the end of the release valve as shown in fig.2.

## 5. OPERATION

### 5.1. BEFORE FIRST USE.

- 5.1.1. Before using jack, purge hydraulic unit in order to eliminate any air in the system. Place handle onto the release valve nut as shown in fig.2 and open the valve by turning the handle anti-clockwise, place the handle back into the jacking socket and pump for 30 to 40 seconds. When complete, close the release valve by turning the valve nut clockwise.
- 5.1.2. Place a few drops of hydraulic jack oil onto the pump piston and pump the handle several times to distribute the oil. Thoroughly lubricate all moving parts.

### 5.2. GENERAL JACKING.

- WARNING!** Before lifting ensure Section 1 safety instructions are read and understood. When lifting a load of maximum capacity or close to it, it is recommended that the effort be reduced by the use of assistance during this operation.
- 5.2.1. Prepare the vehicle as mentioned in the safety instructions ensuring the ground on which the jack is to stand is level and solid (not tarmacadam).
  - 5.2.2. Position the jack saddle under the vehicle manufacturer's recommended lifting point.

### 5.3. RAISING THE VEHICLE.

- 5.3.1. Close the release valve using the handle as shown in fig.2. Place the handle into the handle socket and commence pumping handle up and down using maximum strokes until the jack saddle reaches the vehicle jacking point. Check the jacking point is centrally located on the saddle and raise the vehicle.
- 5.3.2. Should the jack become overloaded, a safety excess pressure valve will open and stop the vehicle from lifting.
  - WARNING!** The jack is a lifting device only and must not be used to support the load. Use correctly rated axle stands to support the load.

### 5.4. LOWERING THE VEHICLE.

- WARNING!** Ensure there are no persons or obstacles beneath the vehicle, or in the path of its descent.
- 5.4.1. If using axle stands, raise the jack high enough for the stands to be easily removed. Then place the handle onto the release valve nut and turn anti-clockwise, very slowly, to open the valve.
  - 5.4.2. The lowering speed is controlled by the amount you turn the handle. Lower carefully, avoid any sudden changes in descent rate which would shock load the hydraulic system.

## 6. MAINTENANCE

- 6.1. When the jack is not in use, the ram should be in its lowest position to minimise corrosion. Remove the handle to inactivate jack.
- 6.2. Keep the jack clean and lubricate all moving parts on a regular basis.
- 6.3. Before each use check for broken, cracked, bent, or loose parts, or any visible damage to ram, pump, saddle, lifting arm, frame and all parts including nuts, bolts, pins and other fasteners. If any suspect item is found remove jack from service and take necessary action to remedy the problem.

- DO NOT** use the jack if believed to have been subjected to abnormal load or shock load.

- 6.4. Periodically check the pump piston and the ram for signs of corrosion. Clean exposed areas with a clean oiled cloth.

- 6.5. After one year the oil should be replaced in order to extend the life of the jack. Use hydraulic jack oil only.

**IMPORTANT:** Only fully qualified personnel should attempt hydraulic maintenance or repair.

- 6.6. To check the oil level, fully lower the jack. Open the hinged cover and remove oil filler plug (fig.3). The correct level is just below the bottom of the plug. If oil level is low, fill as required.

**NOTE:** Use a good quality jack oil, such as SEALEY HYDRAULIC JACK OIL.

- WARNING:** DO NOT use brake fluid, or any fluid other than hydraulic jack oil as this may cause serious damage to the jack and will invalidate the warranty.

- 6.7. When draining the oil make sure that no dirt is allowed to enter the hydraulic system.

**IMPORTANT:** NO RESPONSIBILITY IS ACCEPTED FOR INCORRECT USE OF THIS PRODUCT.

Owing to their size and weight, hydraulic products should ideally be repaired by local service agents. We have service / repair agents in most parts of the UK. Before returning your product please call our technical helpline on 01284 757505 for advice and troubleshooting guidance.

*If the jack is under guarantee please contact your stockist.*

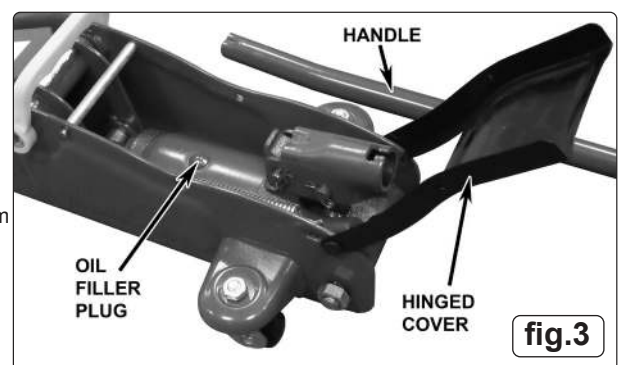

## DECOMMISSIONING THE JACK

Should the jack become completely unserviceable and require disposal, draw off the oil into an approved container and dispose of the jack and the oil according to local regulations.

## 7. TROUBLESHOOTING

**IMPORTANT: MAINTENANCE OR REPAIR OF HYDRAULIC SYSTEM MUST ONLY BE PERFORMED BY A QUALIFIED PERSON.**

PROBLEM	POSSIBLE CAUSE	REMEDY
Jack will not lift the load	<ol style="list-style-type: none"> <li>1) Overloaded</li> <li>2) Oil level low</li> <li>3) Release valve not correctly closed</li> <li>4) Air in system</li> <li>5) Piston rod not functioning</li> <li>6) Packing worn or defective</li> </ol>	<ol style="list-style-type: none"> <li>1) Be sure to use jack with adequate capacity</li> <li>2) Top up oil level</li> <li>3) Check and close release valve</li> <li>4) Open release valve and pump the handle a few times. Close valve and re-try</li> <li>5) Clean and replace oil</li> <li>6) Replace packing</li> </ol>
Jack does not lift high enough or feels "spongy"	<ol style="list-style-type: none"> <li>1) Oil level too high or too low</li> <li>2) Worn seals</li> <li>3) Air in system</li> <li>4) Release valve not closed</li> </ol>	<ol style="list-style-type: none"> <li>1) Fill or remove excess oil</li> <li>2) Return jack to local service agent</li> <li>3) Open release valve and pump the handle a few times. Close valve and re-try</li> <li>4) Check and close release valve</li> </ol>
Jack lifts poorly	<ol style="list-style-type: none"> <li>1) Pump packing or valves malfunctioning</li> <li>2) Oil is dirty</li> <li>3) Air in the system</li> </ol>	<ol style="list-style-type: none"> <li>1) Replace packing and/or clean valves</li> <li>2) Replace oil</li> <li>3) Open release valve and pump the handle a few times. Close valve and re-try</li> </ol>
Jack lifts but will not hold load	<ol style="list-style-type: none"> <li>1) Release valve partially open</li> <li>2) Dirt on valve seats</li> <li>3) Air in system</li> <li>4) Faulty seals</li> <li>5) Packing worn or defective</li> </ol>	<ol style="list-style-type: none"> <li>1) Check and close release valve</li> <li>2) Lower jack, close release valve. Place foot on front wheel and pull up lifting arm to it's full height by hand. Open the release valve to lower arm</li> <li>3) Open release valve and pump the handle a few times. Close valve and re-try</li> <li>4) Replace packing or contact local service agent</li> <li>5) Replace packing</li> </ol>
Jack will not lower completely	<ol style="list-style-type: none"> <li>1) Unit requires lubrication</li> <li>2) Piston rod bent or damaged</li> <li>3) Jack frame/link system distorted due to overloading/poor positioning</li> <li>4) Air in system</li> <li>5) Release valve partially closed</li> <li>6) Jack spring damaged or unhooked.</li> </ol>	<ol style="list-style-type: none"> <li>1) Oil all external moving parts</li> <li>2) Replace rod or contact local service agent</li> <li>3) Replace damaged parts or contact local service agent</li> <li>4) Open release valve and pump the handle a few times. Close valve and re-try</li> <li>5) Check and fully open release valve</li> <li>6) Replace spring or contact local service agent</li> </ol>
Jack does not lower at all	<ol style="list-style-type: none"> <li>1) Release valve closed</li> </ol>	<ol style="list-style-type: none"> <li>1) Check and fully open release valve</li> </ol>



### ENVIRONMENT PROTECTION

Recycle unwanted materials instead of disposing of them as waste. All tools, accessories and packaging should be sorted, taken to a recycling centre and disposed of in a manner which is compatible with the environment. When the product becomes completely unserviceable and requires disposal, drain any fluids (if applicable) into approved containers and dispose of the product and fluids according to local regulations.

Note: It is our policy to continually improve products and as such we reserve the right to alter data, specifications and component parts without prior notice.

Important: No Liability is accepted for incorrect use of this product.

Warranty: Guarantee is 12 months from purchase date, proof of which is required for any claim.



REGISTER YOUR PURCHASE HERE

**Jack Sealey Ltd t/a Sealey Group**, Kempson Way, Suffolk Business Park, Bury St Edmunds, Suffolk, IP32 7AR UK  
**Jack Sealey (EU) Ltd t/a Sealey Group**, Farney Street, Carrickmacross, Co. Monaghan, A81 PK68 Ireland  
**Tel:** 01284 757500 • **Email:** sales@sealey.co.uk • **Web:** www.sealey.co.uk