



STARTER/CHARGERS 12/24V 230V

START320 320/45AMP

START420 420/60 AMP

START560.V2 560/90AMP

START660 660/100AMP

Thank you for purchasing a Sealey product. Manufactured to a high standard, this product will, if used according to these instructions, and properly maintained, give you years of trouble free performance.



Refer to Instruction Manual



Wear eye Protection



Warning: Corrosive substance



Wear Protective Gloves



Warning: Electricity



Protect From Rain

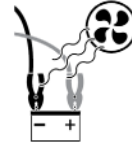

Use in Well Ventilated Areas



Keep away from sources of ignition: Battery could explode

1. SAFETY

1.1. ELECTRICAL SAFETY

- ❑ **WARNING!** It is the responsibility of the owner and the operator to read, understand and comply with the following: You must check all electrical products, before use, to ensure that they are safe. You must inspect power cables, plugs, sockets and any other connectors for wear or damage. You must ensure that the risk of electric shock is minimised by the installation of appropriate safety devices. A Residual Current Circuit Breaker (RCCB) should be incorporated in the main distribution board. We also recommend that a Residual Current Device (RCD) is used. It is particularly important to use an RCD with portable products that are plugged into a supply which is not protected by an RCCB. If in any doubt consult a qualified electrician. You may obtain a Residual Current Device by contacting your Sealey dealer.

1.1.1. You must also read and understand the following instructions concerning electrical safety.

1.1.2. The Electricity at Work Act 1989 requires that all portable electrical appliances, if used on business premises, are tested by a qualified electrician, using a Portable Appliance Tester (PAT), at least once a year.

1.1.3. The Health & Safety at Work Act 1974 makes owners of electrical appliances responsible for the safe condition of those appliances and the safety of the appliance operators. If in any doubt about electrical safety, contact a qualified electrician.

1.1.4. Ensure that the insulation on all cables and on the appliance is safe before connecting it to the power supply. See 1.1.1. and 1.1.2. and use a Portable Appliance Tester.

1.1.5. Ensure that cables are always protected against short circuit and overload.

1.1.6. Regularly inspect power supply leads and plugs for wear and damage and power connections to ensure that none is loose or damaged.

Important: Ensure that the voltage marked on the appliance matches the power supply to be used and that the plug is fitted with the correct fuse - see fuse rating at right.

1.1.7. DO NOT pull or carry the appliance by the power cable.

1.1.8. DO NOT pull the plug from the socket by the cable.

1.1.9. DO NOT use worn or damaged cables, plugs or connectors. Immediately have any faulty item repaired or replaced by a qualified electrician.

1.1.10. This product requires an electrical supply in excess of 13 amp, and NO plug is fitted. You must therefore contact a qualified electrician to ensure that a 16A/32A (depending on the model) supply is available. We recommend that you discuss the installation of a industrial round pin plug and socket with your electrician.

Ensure that the unit is correctly earthed via a three-pin plug, as shown. ⚡

- a) **Connect the GREEN/YELLOW earth wire to the earth terminal.**
- b) **Connect the BROWN live wire to live terminal 'L'.**
- c) **Connect the BLUE neutral wire to the neutral terminal, 'N' or unmarked.**
- d) **After wiring, check that there are no bare wires, that all wires have been correctly connected, that the external insulation extends beyond the cable restraint and that the restraint is tight.**

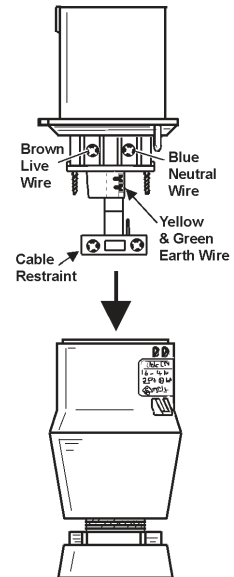

IT IS RECOMMENDED THAT THE MINIMUM SUPPLY TO THIS PRODUCT IS FITTED WITH A 16A*/32A (depending on the model) FUSE OR BREAKER

1.1.11. If an extension reel is used it should be fully unwound before connection. A reel with an RCD fitted is preferred since any appliance plugged into it will be protected. The cable core section is important and should be at least 1.5mm², but to be absolutely sure that the capacity of the reel is suitable for this product and for others which may be used in the other output sockets, we recommend the use of 2.5mm² section cable.

1.2. GENERAL SAFETY

- ▲ **DANGER! BE AWARE, LEAD-ACID BATTERIES GENERATE EXPLOSIVE GASES DURING NORMAL BATTERY OPERATION. FOR THIS REASON, IT VERY IMPORTANT TO READ AND FOLLOW THESE INSTRUCTIONS CAREFULLY, EACH TIME YOU USE THE CHARGING EQUIPMENT.**

1.2.1. Follow these instructions and those published by the battery and vehicle manufacturers, and the maker of any equipment you intend to use in the vicinity of the battery. Remember to review warning marks on all products and on engines.

- WARNING!** Modern vehicles contain extensive electronic systems. You are required to check with the vehicle Manufacturer, for any specific instructions regarding the use of this type of equipment on each vehicle.
- 1.2.2. No liability will be accepted for damage / injury, where this product is not used in accordance with all instructions.
- 1.3. **PERSONAL PRECAUTIONS**
 - ✓ Ensure there is another person within hearing range of your voice and close enough to come to your aid, should a problem arise when working near a lead-acid battery.
 - ✓ Wear safety eye protection and protective clothing. Avoid touching eyes while working near battery.
 - ✓ Have fresh water and soap nearby in case battery acid contacts skin, clothing or eyes.
 - ✓ Wash immediately with soap and water if battery acid contacts skin or clothing. If acid enters eye, flush eye immediately with cool, clean running water for at least 15 minutes and seek immediate medical attention.
 - ✓ Remove personal metallic items such as rings, bracelets, necklaces and watches. A lead-acid battery can produce a short-circuit current which is high enough to weld a ring or the like to metal, which would cause severe burns.
 - ✓ Ensure hands, clothing (especially belts) are clear of fan blades and other moving or hot parts of engine, remove ties and contain long hair.
 - ✗ **DO NOT** smoke or allow a spark or flame in the vicinity of battery or engine.
- 1.4. **GENERAL SAFETY INSTRUCTIONS**
 - ✓ Familiarise yourself with the application and limitations of the charger as well as the potential hazards. Also refer to the vehicle manufacturer's hand book. **IF IN ANY DOUBT CONSULT A QUALIFIED ELECTRICIAN.**
 - ✓ Ensure the charger is in good order and condition before use. If in any doubt do not use the unit, contact your Sealey stockist.
 - ✓ Use the starter/charger in the upright position only and ensure it is placed on a stable surface which will adequately support its weight.
 - ✓ Ensure the charger is disconnected from the mains supply before attaching/detaching the power clamps to/from the battery.
 - ✓ Keep tools and other items away from the engine and ensure you can see the battery and working parts of engine clearly.
 - ✓ Ensure the output of the charger is the same voltage as the battery.
 - ✓ Ensure that during charging, the charger is placed in a location where there is sufficient ventilation to prevent the build up of explosive gases from a lead acid battery, and **DO NOT** cover or obstruct the charger ventilation louvres.
 - ✓ If battery has caps to access the battery fluid, remove the caps and check the fluid level before connecting the power clamps.
 - ✓ If necessary top-up the battery with distilled water by referring to the battery manufacturer's instructions (Apply the personal safety precautions described in part 1.3).
 - ✓ If the charger receives a sharp knock or blow the unit must be checked by a qualified service agent before using.
 - ✓ If the battery terminals are corroded or dirty clean them before attaching the power clamps.
 - ✓ Keep children and unauthorised persons away from the working area.
 - ✗ **DO NOT** dis-assemble the charger for any reason. The charger must only be checked by qualified service personnel.
 - ✗ **DO NOT** try to charge a non-rechargeable battery.
 - ✗ **DO NOT** try to charge battery if battery fluid is frozen.
 - WARNING!** To prevent the risk of sparking, short circuit and possible explosion **DO NOT** drop metal tools in the battery area, or allow them to touch the battery terminals.
 - ✗ **DO NOT** allow power clamps to touch each other or to make contact with any metallic part of the vehicle.
 - ✗ **DO NOT** cross connect power leads from charger to battery. Ensure positive (+/RED) is to positive and negative (-/BLACK) is to negative.
 - ✗ **DO NOT** pull the cables or clamps from the battery terminals.
 - ✗ **DO NOT** use the charger outdoors, or in damp, or wet locations and **DO NOT** operate within the vicinity of flammable liquids or gases.
 - ✗ **DO NOT** use charger inside vehicle or inside engine compartment.
 - ✓ Ensure there is effective ventilation to prevent a build-up of explosive gases, and do not cover or obstruct charger ventilation louvres.
 - ✗ **DO NOT** use the charger for a task for which it is not designed.
 - WARNING!** **DO NOT** simultaneously charge batteries of different capacities or discharge levels.
 - WARNING!** If a fuse blows, ensure it is replaced with an identical fuse type and rating. Use only Sealey genuine parts.
 - ✓ When not in use, store the charger carefully in a safe, dry, childproof location.

This appliance can be used by children aged from 8 years and above and persons with reduced physical, sensory or mental capabilities or lack of experience and knowledge if they have been given supervision or instruction concerning use of the appliance in a safe way and understand the hazards involved. Children shall not play with the appliance. Cleaning and user maintenance shall not be made by children without supervision.

2. INTRODUCTION

Heavy duty starter/chargers for professional garages, workshops or body shops. The START range caters for all requirements from cars right up to light commercial vehicles. Model numbers START560, START660 feature a fast-charge timer device to enable rapid battery recovery with reduced risk of boiling the battery. All models have large wheels for easy mobility and feature analogue ammeters and switchable charge circuitry for accurate charge control.

3. SPECIFICATION

Model no: START320
 Output: 12/24V
 Output charge peak(EN): 45A(30A)
 Output start peak(EN): 320A(220A)
 Battery range: 30-500Ah
 Input charge: 5A
 Input start: 20A
 Charging rates: 3
 Supply: 230V - 16A Supply
 Polarity protection: Fuse (1 x 110A)
 Consumable parts:
 START360.F10 (Pack of 10) START360.F (Single)

Note: Performance dependent on connection to an adequate good clean electric supply.

Model no: START420
 Output: 12/24V
 Output charge peak(EN): 60A(40A)
 Output start peak(EN): 420A(280A)
 Battery range: 30-700Ah
 Input charge: 6.5A
 Input start: 22A
 Charging rates: 3
 Supply: 230V - 16A Supply
 Polarity protection: Fuse (1 x 110A)
 Consumable parts:
 START360.F10 (Pack of 10) START360.F (Single)

Note: Performance dependent on connection to an adequate good clean electric supply.

Model no: START560.V2
 Output: 12/24V
 Output charge peak(EN): 95A(65A)
 Output start peak(EN): 560A(360A)
 Battery range: 50-1000Ah
 Input charge: 11.5A
 Input start: 44A
 Charging rates: 6
 Supply: 230V - 32A Supply
 Polarity protection: Fuse (2 x 110A)
 Consumable parts:
 START360.F10 (Pack of 10) START360.F (Single)
 Note: Performance dependent on connection to an adequate good clean electric supply.

Model no: START660
 Output: 12/24V
 Output charge peak(EN): 100A(70A)
 Output start peak(EN): 660A(400A)
 Battery range: 50-1200Ah
 Input charge: 12.5A
 Input start: 46A
 Charging rates: 6
 Supply: 230V - 32A Supply
 Polarity protection: Fuse (2 x 110A)
 Consumable parts:
 START360.F10 (Pack of 10) - Fuse, START360.F (Single) - Fuse
 Note: Performance dependent on connection to an adequate good clean electric supply.

4. OPERATION

Refer to fig.1

- 4.1. ASSEMBLY
- 4.1.1. Slide the axle through the casing at the bottom rear corner. Slide a wheel on to each end of the axle and retain them with the circlips provided.
- 4.2. PREPARATION
- 4.2.1. It is important to correctly prepare for charging ensuring that you follow Section 1 safety requirements carefully.
- 4.2.2. Check that the capacity of the battery is compatible with charger output.
- 4.2.3. Follow any vehicle manufacturer's instructions regarding battery charging. Note special instructions for the charging of non-removable vehicle batteries.
- 4.2.4. Check battery to ensure that the POSITIVE and NEGATIVE terminals are clearly identifiable before removing the battery from the vehicle.
- 4.2.5. Disconnect and remove the battery from the vehicle and place in an appropriate safe area ready for charging.
- 4.2.6. Remove the battery electrolyte cover or caps to allow the gases produced by charging to escape.
- 4.2.7. Check that the electrolyte fluid level in the battery is above the plates. If not, add distilled water to cover them by 5-10mm. DO NOT touch the battery fluid as it is corrosive.
- 4.2.8. The correct charging status of the battery may be determined by using a hydrometer which will measure the specific density of the electrolyte. The following figures (kg/ltr) apply at 20°C:
 1.28 = Fully charged, 1.21 = Half charged, 1.14 = Fully discharged.
- ❑ **WARNING!** Be cautious and vigilant as the electrolyte is highly corrosive sulphuric acid.
- 4.3. CONNECTING CHARGER TO BATTERY
- 4.3.1. For chargers with dual voltage output, set the charger voltage to match that of the battery (i.e. 12 or 24 volts) by connecting the positive (red) clamp lead to either the 12 volt + output terminal or the 24 volt + output terminal as appropriate.
- 4.3.2. Check the charger clamps and battery terminals to ensure that they are clean and free from oxidation.
- 4.3.3. First connect the charger POSITIVE (Red or +) lead to the POSITIVE (+) terminal of the battery and then the NEGATIVE (Black or -) lead to the NEGATIVE (-) terminal of the battery.
- 4.4. CHARGING THE BATTERY
- 4.4.1. Connect the charger to the mains power supply and set the rate of charge according to your model type as follows:
 START320 and START420 (see fig.2)
 Set the mode switch to the 'charge' function indicated by the battery symbol.
 LOW charging rate:- select min & 1
 MEDIUM charging rate:- select min & 2
 HIGH charging rate:- select Boost only (please note that when Boost is selected the switch marked 1 & 2 is over-riden)
 START560.V2 and START660 (see fig.3).
 Select charge level 1,2,3,4,5, or 6 using the rotary switch above the timer.
- 4.4.2. Check the current delivery to the battery by reading the ammeter on the front of the battery charger (fig.4, ammeter face may vary by model). Initially, there will be a high rate of charge which will slowly decrease according to the capacity and condition of the battery.
 NOTE: If the charger is connected to a fully charged battery the ammeter will show a low output, no charging is necessary.

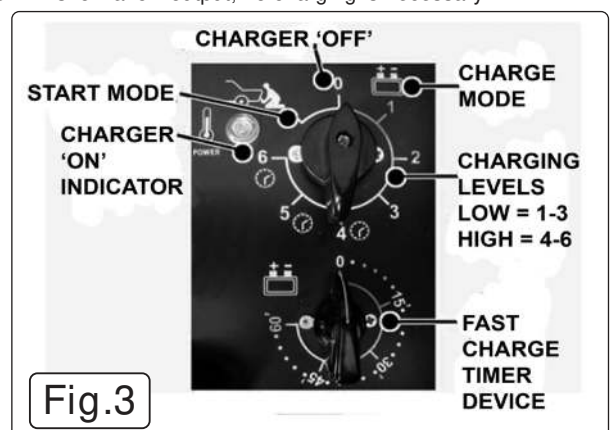
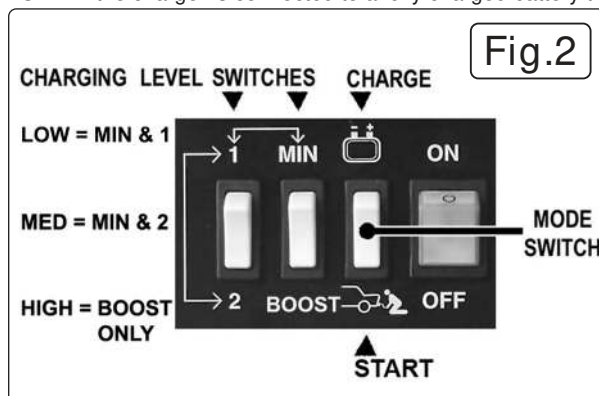
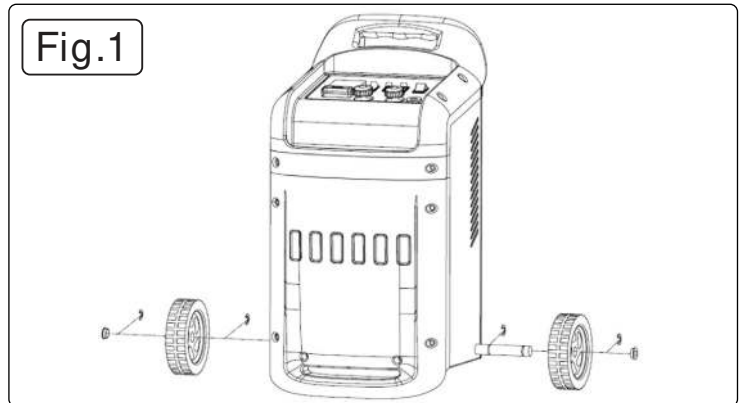

4.5. SEALED BATTERIES

4.5.1. Charge a sealed battery very slowly, carefully monitoring the voltage across the battery terminals using a normal tester.

4.5.2. When the battery terminal voltage reaches 14.4V for 12V batteries or 28.8V for 24V batteries, stop charging.

4.6. MULTIPLE CHARGING

- **WARNING! DO NOT** simultaneously charge different types of battery or batteries with different capacities or levels of discharge.

4.6.1. Simultaneous multiple charging should be carried out in series, since this enables monitoring of the current circulating in each battery. See fig.5 below.

NOTE: If two batteries with rated voltages of 12V are connected in series, set the battery voltage selection key on the front panel to 24V and move the positive cable to the 24V terminal.

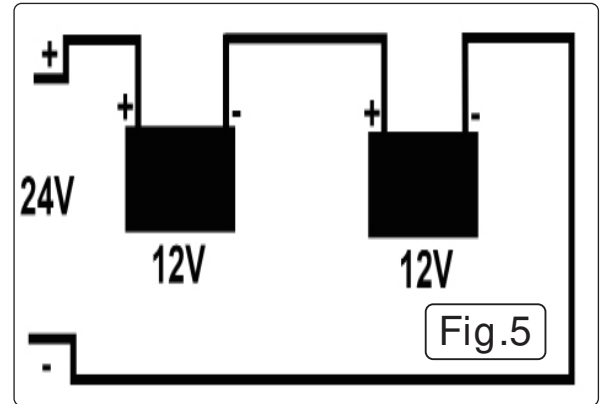
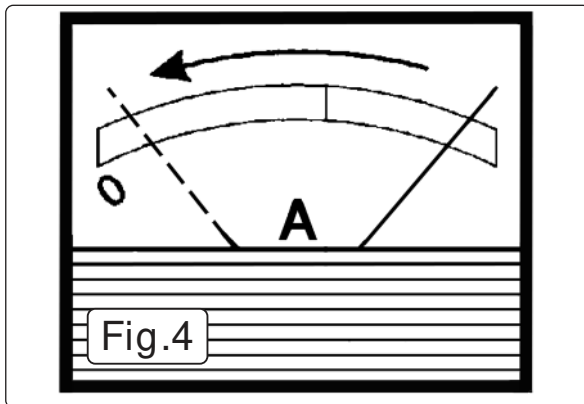

4.6.2. When fully charged, the ammeter reading should be close to "0" and the electrolyte in the battery should begin to gas. Stop charging to protect the battery plates from damage.

DO NOT continue to charge a fully charged battery, as this will damage the battery. DO NOT leave a battery on charge unattended.

4.7. END OF CHARGING

4.7.1. Switch the charger off and unplug from mains power. Disconnect the power clamps, clean the charger and store in a safe, dry area.

4.7.2. Replace the battery electrolyte cover or caps. Wipe up any splashes or spillage (remember that the electrolyte is a corrosive acid).

4.7.3. Return the battery to the vehicle, secure according to the manufacturer's instructions and re-connect. Check to ensure that all tools are removed before closing the bonnet or boot.

4.8. RAPID CHARGING

4.8.1. The START560 and the START660 both have a rapid charge function which is controlled by the fast-charge timer device to a maximum of 60 minutes.

4.8.2. To initiate rapid charging turn the fast-charge timer device to the required charging time in minutes and turn the charging level rotary switch to one of the fast-charge charging levels of either 4,5 or 6. When the preset time has elapsed the current is automatically switched off. Turn the charging level rotary switch to the 'off' position.

4.9. STARTING

- **WARNING! DO NOT** attempt to start engine with starter/charger if the battery is disconnected from the vehicle. The presence of the battery is essential for the elimination of possible over voltage that may be generated due to energy accumulating in the connection cables at the starting stage.

4.9.1. Check the vehicle manufacturer's handbook and follow any special instructions. Check that the battery is in good condition.

4.9.2. Insure the starter/charger is disconnected from the mains power supply and, for models with dual voltage output, set the output voltage to the same as the vehicle battery i.e. 12 or 24 volts.

4.9.3. Check that the charger clamps and battery terminals are clean and free from oxidation.

4.9.4. Without removing the cables that connect the battery to the vehicle, first connect the charger POSITIVE (red) lead to the POSITIVE (+) terminal on the battery. Then connect the NEGATIVE (-) (black) lead to the chassis, remote from the battery and the fuel line. Starting will be greatly eased if the battery is given a short charge before the ignition switch is turned. This must always be done with the selector switch set to the charge position and NOT to boost. Plug starter/charger into mains power supply, select a low rate of charge and turn on. Allow the battery to charge for 2-3 minutes.

4.9.5. Move the starter/charger switch to the 'START' position (see figs.2 & 3). Turn the vehicle ignition on and crank the engine for a MAXIMUM of 3 seconds. If the vehicle does not start, wait 120 seconds and then try again to a maximum of 5 cycles.

- **WARNING! If the vehicle will not start, DO NOT** continue as vehicle battery and electrical circuits may be damaged, and the fuse in the charger will blow. Disconnect the charger and investigate for vehicle faults.

4.9.6. When the vehicle is running successfully, switch the starter/charger off, unplug from the mains power and disconnect the power terminals from the battery.

4.10. FUSE

4.10.1. The starter/charger is equipped with a safety fuse, or fuses, which will cut the power to the unit in the following circumstances:

- a) Overload - too high a current to the battery.
- b) Short circuit - clamps touch, or cross-connection to battery.
- c) Prolonged starting attempts.

4.10.2. Should the fuse blow take the following action:

Turn the unit off and disconnect from the mains power supply.

Allow the unit to cool down, establish the reason for failure and correct.

Replace the fuse (under fuse cover on control panel). DO NOT use a fuse with copper bridge or similar as these will damage your starter/charger. Refer to Section 2 'Specifications' for fuse information. We recommend that you hold 2 spare fuses with the starter/charger.

NOTE: The use of an incorrect fuse will invalidate your warranty.



ENVIRONMENT PROTECTION

Recycle unwanted materials instead of disposing of them as waste. All tools, accessories and packaging should be sorted, taken to a recycling centre and disposed of in a manner which is compatible with the environment. When the product becomes completely unserviceable and requires disposal, drain any fluids (if applicable) into approved containers and dispose of the product and fluids according to local regulations.



WEEE REGULATIONS

Dispose of this product at the end of its working life in compliance with the EU Directive on Waste Electrical and Electronic Equipment (WEEE). When the product is no longer required, it must be disposed of in an environmentally protective way. Contact your local solid waste authority for recycling information.

Note: It is our policy to continually improve products and as such we reserve the right to alter data, specifications and component parts without prior notice. Please note that other versions of some of these products are available. If you require documentation for alternative versions, please email or call our technical team on technical@sealey.co.uk or 01284 757505.

Important: No Liability is accepted for incorrect use of this product.

Warranty: Guarantee is 12 months from purchase date, proof of which is required for any claim.

Jack Sealey Ltd t/a Sealey Group, Kempson Way, Suffolk Business Park, Bury St Edmunds, Suffolk, IP32 7AR UK

Jack Sealey (EU) Ltd t/a Sealey Group, Farney Street, Carrickmacross, Co. Monaghan, A81 PK68 Ireland

Tel: 01284 757500 • **Email:** sales@sealey.co.uk • **Web:** www.sealey.co.uk