



2108MM HEAVY-DUTY MODULAR FULL HEIGHT FLOOR CABINET

MODEL NO: **APMS21**

Thank you for purchasing a Sealey product. Manufactured to a high standard, this product will, if used according to these instructions, and properly maintained, give you years of trouble free performance.

IMPORTANT: PLEASE READ THESE INSTRUCTIONS CAREFULLY. NOTE THE SAFE OPERATIONAL REQUIREMENTS, WARNINGS & CAUTIONS. USE THE PRODUCT CORRECTLY AND WITH CARE FOR THE PURPOSE FOR WHICH IT IS INTENDED. FAILURE TO DO SO MAY CAUSE DAMAGE AND/OR PERSONAL INJURY AND WILL INVALIDATE THE WARRANTY. KEEP THESE INSTRUCTIONS SAFE FOR FUTURE USE.



Refer to instructions



Wear protective gloves

1. SAFETY

- ❑ **WARNING!** Ensure Health & Safety, local authority, and general workshop practice regulations are adhered to when using this storage system.
- ✓ Locate in a suitable work area.
- ✓ Keep the work area clean, uncluttered and ensure there is adequate lighting.
- ❑ **WARNING!** Use storage on level and solid ground, preferably concrete.
- ✓ Keep the storage system clean and tidy in accordance with good workshop practice.
- ✓ Keep children and unauthorised persons away from the work area.
- ✓ Be aware when assembling of sharp edges. Wear gloves.
- ✓ During assembly of the cabinet you may require the assistance of another person.
- * **DO NOT** use the storage system for any purpose other than that for which it is designed.
- * **DO NOT** use the storage system outdoors.
- * **DO NOT** place the storage system in a damp or wet location or an area where there is condensation.
- * **DO NOT** clean the storage system with any solvents which may damage the surfaces or the protective coating.
- * **DO NOT** move the storage system when there are items placed inside.
- * **DO NOT** step on the shelves.
- * **DO NOT** overload the storage system.

2. INTRODUCTION

Use as part of a complete professional garage storage system or as an individual storage unit. All steel construction with a graphite powder coat finish. Heavy-duty full height single door cabinet. Three adjustable shelves. Four level-adjusting feet. Added security provided by cylinder lock, supplied with two keys. Requires some self-assembly. Supplied flat-packed for ease of transportation.

3. SPECIFICATION

Model No: APMS21
Overall Size (W x D x H): 610 x 610 x 2108mm

4. CONTENTS

ITEM	DESCRIPTION	QTY
1	Top panel	1
2	Back panel	1
3	M6 x 12 Cross head screw	40
4	Right side panel	1
5	Shelf	3
6	Shelf support	12
7	Bottom panel	1
8	Metal foot	4
9	Adjustable foot	4
10	Skirting board	1
11	Door	1
12	Lock	1
13	M4 x 8 Cross head screw	2
14	Door handle	1
15	Left side panel	1

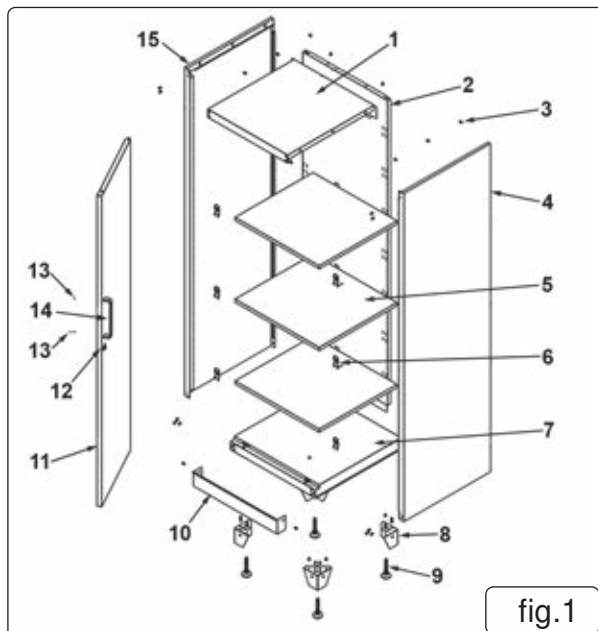

fig. 1



5. ASSEMBLY

5.1. BOTTOM PANEL ASSEMBLY

- 5.1.1. Secure the metal feet (fig 2 - 8) to the bottom panel (fig 2 - 7) with M6 x 12 cross head screws (fig 2 - 3).
- 5.1.2. Locate and thread the adjustable feet (fig 2 - 9) into the bottom panel.

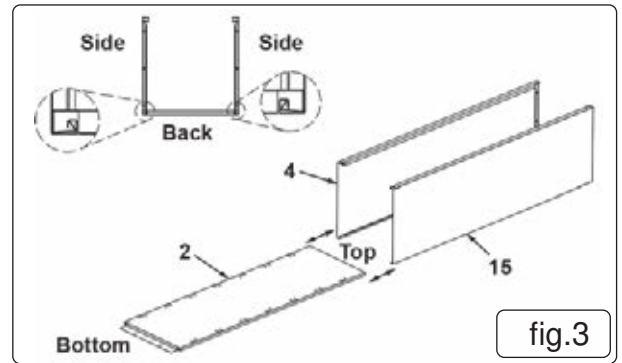
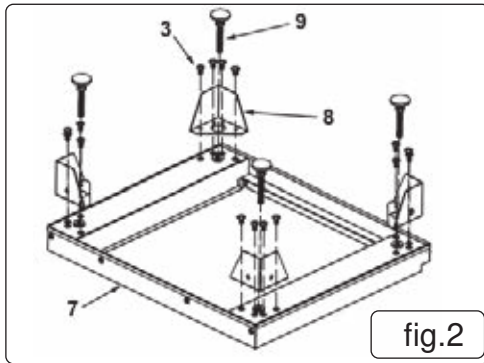

5.2. PANEL ASSEMBLY

- 5.2.1. Prior to panel assembly lay a soft mat or similar on the floor to protect the paint finish
- 5.2.2. Attach right side panel (fig 3 - 4) to back panel (fig 3 - 2) by sliding it's edge into the groove on the side edge of the back panel.
- 5.2.3. Repeat for left side panel (fig 3 - 15).

5.3. BOTTOM PANEL AND SIDES ASSEMBLY

- 5.3.1. Locate and align bottom panel assembly fixing holes with the fixing holes in the side and bottom panel assembly (fig 4).
- 5.3.2. Secure with M6 x 12 cross head screws (fig 4 - 3).

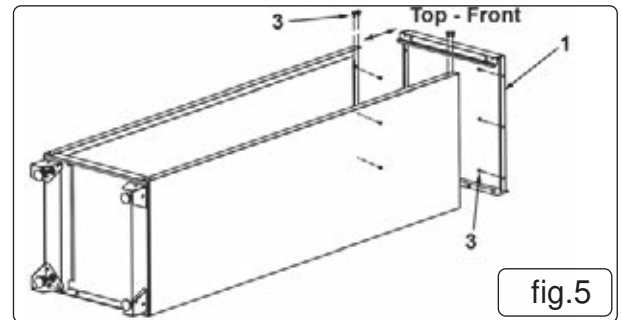
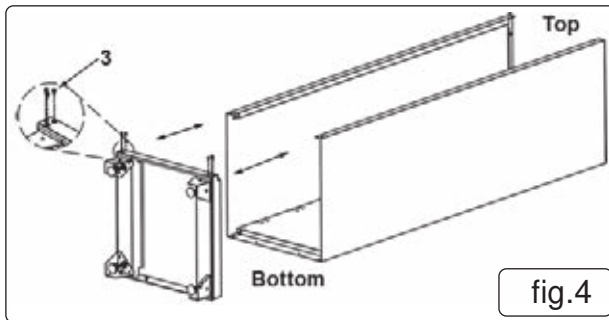

5.4. TOP PANEL TO SIDES ASSEMBLY

- 5.4.1. Locate and align top panel (fig 5 - 1) with fixing holes in the side panels and secure with M6 x 12 cross head screws (fig 5 - 3).
- 5.4.2. Secure top panel (fig 5 - 1) to front fixing holes on side panels with M6 x 12 cross head screws (fig 5 - 3).

5.5. FINAL PANEL FIXINGS

- 5.5.1. With the assistance of another person rotate the cabinet assembly onto it's side (fig 6).
- 5.5.2. Secure the remaining fixings of the bottom panel assembly and top panel with M6 x 12 cross head screws (fig 6 - 3).

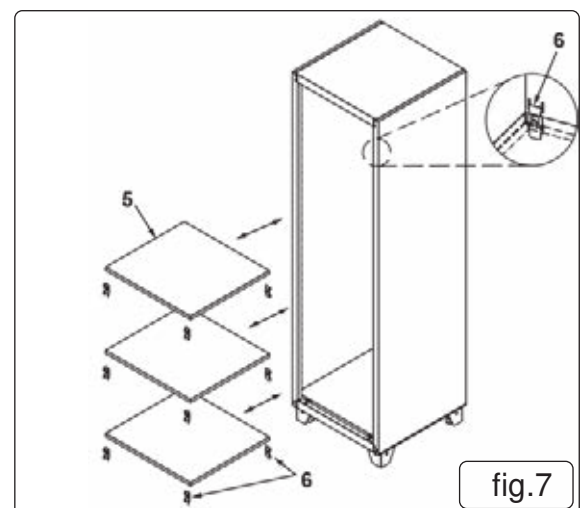
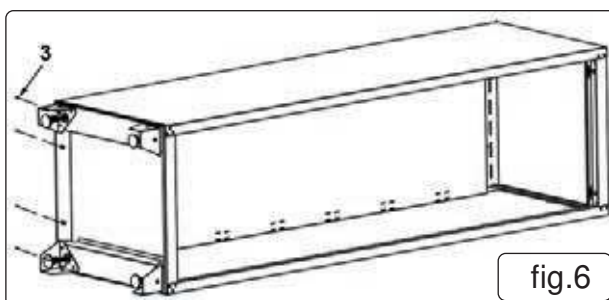

5.6. ATTACHING THE SHELVES

- 5.6.1. With the assistance of another person stand the cabinet upright (fig 7).
- 5.6.2. Insert the shelf supports (fig 7 - 6) into the slots on the back panel and inner face of the front panel, at the desired heights.
- 5.6.3. Fit the shelf (fig 7 - 5) onto the appropriate set of shelf supports.
- 5.6.4. Press the shelf firmly until locked onto the shelf supports.
- 5.6.5. The shelves can be adjusted by removing them off the supports and repositioning the supports at the new desired height.

5.7. ATTACHING THE DOOR

NOTE: The door (fig 8 - 11) has a pin fitted at the bottom and a spring bolt fitted at the top.

- 5.7.1. Locate the bottom pin into the hole at the front of the base unit assembly (fig 8).
- 5.7.2. Pull the top spring pin down and align with the hole in the top panel rail (fig 8).
- 5.7.3. Release the top spring to allow the bolt to locate into the hole.

5.8. ATTACHING THE DOOR HANDLE

- 5.8.1. Locate the door handle (fig 9 - 14) to it's corresponding fixing holes, on the door, and secure with M4 x 8 cross head screws (fig 9 - 13).

5.9. ATTACHING THE SKIRTING BOARD

5.9.1. Prior to attaching the skirting board level the cabinet by rotating the adjusting feet (fig 2 - 9) to suit.

5.9.2. Attach the skirting board (fig 9 - 10) into position and secure with M6 x 12 cross head screws (fig 9 - 3).

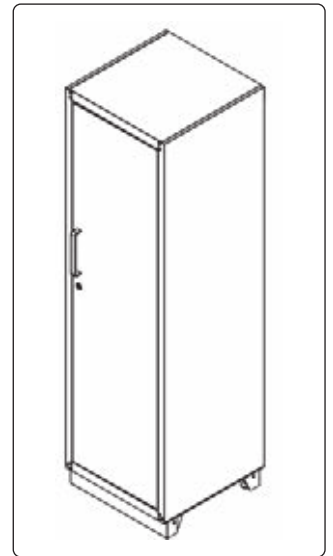
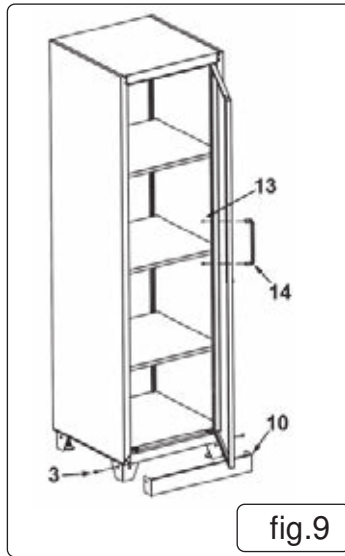
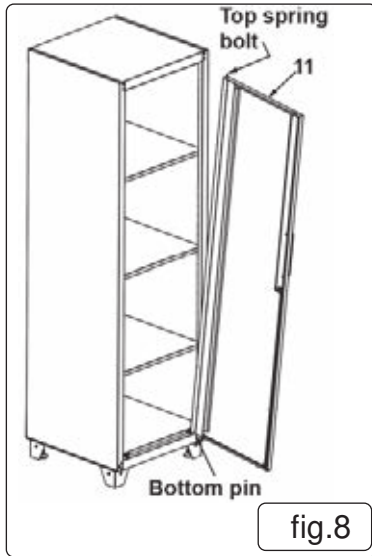

ENVIRONMENT PROTECTION

Recycle unwanted materials instead of disposing of them as waste. All tools, accessories and packaging should be sorted, taken to a recycling centre and disposed of in a manner which is compatible with the environment. When the product becomes completely unserviceable and requires disposal, drain any fluids (if applicable) into approved containers and dispose of the product and fluids according to local regulations.

Note: It is our policy to continually improve products and as such we reserve the right to alter data, specifications and component parts without prior notice.

Important: No Liability is accepted for incorrect use of this product.

Warranty: Guarantee is 12 months from purchase date, proof of which is required for any claim.

Sealey Group, Kempson Way, Suffolk Business Park, Bury St Edmunds, Suffolk. IP32 7AR



01284 757500



01284 703534



sales@sealey.co.uk



www.sealey.co.uk