

INSTALLATION INSTRUCTIONS

EMX & EMX-L

True RMS Energy Meter

For 0.333V CTs and Rogowski Coils

BACnet/Modbus/Pulse



FEATURES

The Senva EMX Advanced Energy Meter is a 3 channel True RMS revenue-grade energy meter. The EMX meets ANSI C12.20 Class 0.2 Standards. The EMX supports both BACnet MS/TP and Modbus RTU protocols and also includes 2 pulse inputs and 2 pulse outputs.

The EMX supports metering CTs with either a 0.333V voltage output or di/dt signal. The EMX is a class 2 low voltage device for mounting flexibility.

EMX-L

Unless specified, "EMX" is used interchangeably.

EMX-L is an EMX without the following features:

- Display
- Logging
- RTC

The EMX-L has been designed for use along with the SenvaSync app. The SenvaSync app can be used to interface with a number of Senva devices, and can be found in the Apple and Android app stores.

MOUNTING

The Senva EMX Advanced Energy Meter is suitable for installation on T35 DIN rail. Simply place unit approximately centered over the mounted DIN rail and press upward until the bottom clicks into place. Using a flat-nose screwdriver, pull top tab and apply pressure downward until unit is flush and release the tab. See Dimensions section for details.

WIRING

EMX Wiring

Using Traditional metering CTs please wire according to the following diagram.



Wiring for connections labeled "Class 2" shall be permanently separated from those labeled "Class 1" by a minimum of 6 mm by means of clamping, routing, or equivalent means.

Class 2

Class 1

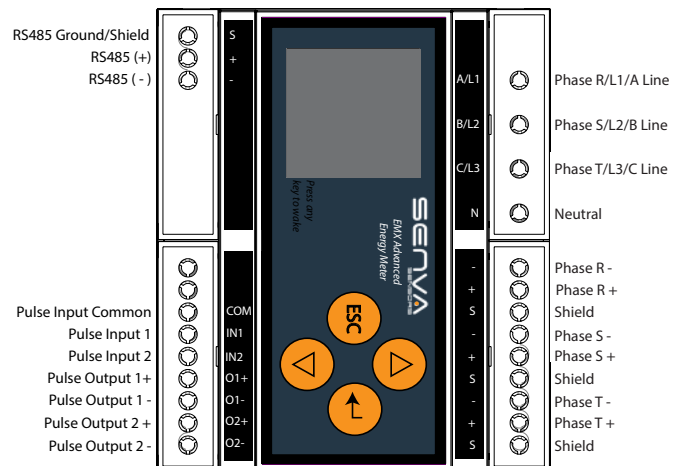

DANGER

HAZARD OF ELECTRIC SHOCK, EXPLOSION, OR ARC FLASH

Failure to follow these instructions may cause serious injury or death

- Do not use this product for life safety applications.
- Do not install this product in hazardous or classified locations.
- Only qualified trade installers should install, program, maintain and test system incorporated therein. Installer is responsible for compliance of all applicable codes.
- Read, understand, and follow instructions thoroughly.
- The Standard CTs associated with this product must be mounted inside a suitable fire and electrical enclosure. For safe electrical work practices, see NFPA 70E in the USA or applicable local standards and codes.
- Replace all doors, covers, and protective devices before powering the equipment.
- Product may use multiple voltage/power sources. Disconnect ALL sources before servicing.
- Use a properly rated voltage sensing device to confirm that power is off. DO NOT depend on this product for voltage indication.
- The installer is responsible for conformance to all applicable codes.
- For use with Listed Energy Monitoring Current Transformers.
- Use Copper Conductors Only
- Per IEC 61010-1 section 8.2.2 "impact test", this product tested with energy of 2J (reduced from 5J) code: IK07



WARNING

Failure to follow these instructions may cause injury, death or equipment damage.

- If product is used in a manner not specified by the manufacturer, the protection provided by the product may be impaired. No responsibility is assumed by the manufacturer for any consequences arising out of the use of this material.

LIMITATION OF LIABILITY

Senva's liability, whether in contract, in tort, under any warranty, in negligence or otherwise shall not exceed the amount of the purchase price paid by the purchaser for the product. Under no circumstances shall Senva be liable for special or consequential damages.

WIRING (CONT.)



WARNING: To reduce the risk of electric shock, always open or disconnect circuit from power distribution system (or service) or building before installing or servicing current transformers.

Current Wiring

For all phases a compatible metering CT has either a 0.333V voltage output or di/dt signal. The wiring shown below corresponds to a Senva Metering CT and may not represent the coloring for all compatible CTs.

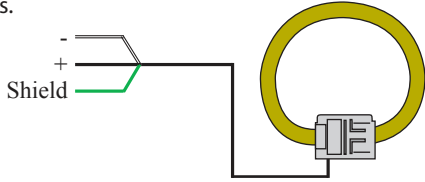

Current transformers are not suitable for Class 2 wiring methods and not intended for connection to Class 2 equipment.

Field installed current transformers can be installed in panel boards or switch gear enclosures and shall be installed according to the following:

1. Always open or disconnect circuit from power-distribution system (or service) of building before installing or servicing current transformers.
2. The current transformers may not be installed in equipment where they exceed 75 percent of the wiring space of any cross-sectional area within the equipment.
3. Restrict installation of current transformer in an area where it would block ventilation openings.
4. Restrict installation of current transformer in an area of breaker arc venting.
5. Secure current transformer and route conductors so that they do not directly contact live terminals or bus.

Voltage Wiring

UL 240.21 code permits qualified installers to forgo use of a disconnect device (fuses or circuit breakers) when connecting the voltage reference of the CT, as long as the tap does not exceed 10 feet and complies with additional guidelines regarding ampacity rating, enclosure spacing and point of connection. It is the responsibility of the installer to ensure the system meets the requirements of the UL 240.21 code.

If the installation does not conform with the UL 240.21 code or the voltage reference must be extended beyond 10 feet, proper use of over current protection is required (i.e., fusing or circuit breakers.)

In the U.S. and Canada, disconnecting fuse holders or circuit breakers can be used. Place this device in close proximity to the CT and within easy reach of the operator, and mark it as the disconnecting method. The disconnect shall meet the relevant requirements of IEC 60947-1 and IEC 60947-3 and shall be suitable for the application. Provide over-current protection and disconnecting method for supply conductors with approved current limiting devices suitable for protecting the wiring.

WIRING DIAGRAMS

1Ø 2-WIRE 120 to 600VAC

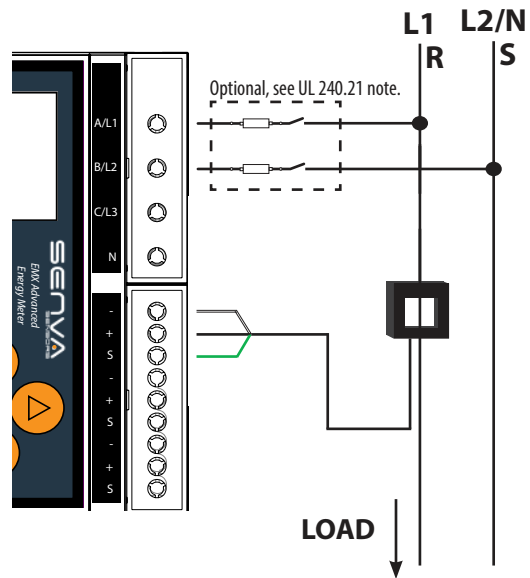

1Ø 3-WIRE 120 to 600VAC

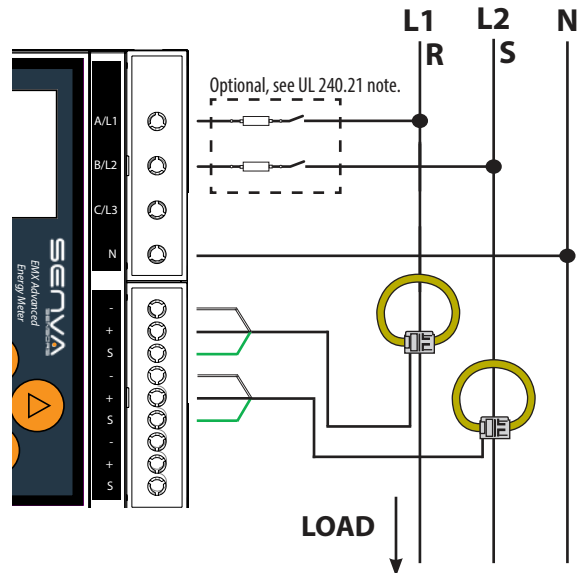

3Ø 3-WIRE 120 to 600VAC

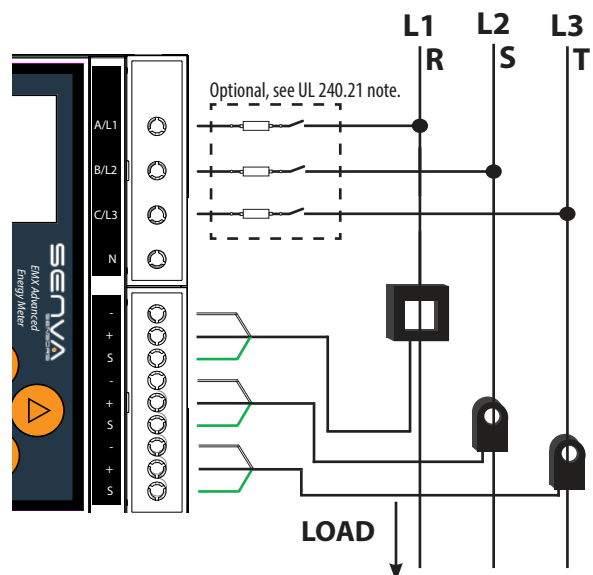

WIRING DIAGRAMS (CONT.)

3Ø 4-WIRE 120 to 600VAC

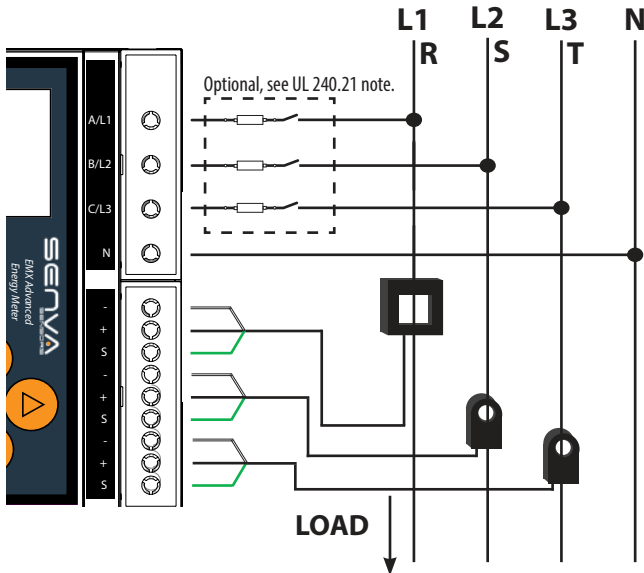

OPERATION (CONT.)

RS485 setup

The EMX is designed to easily connect to an existing communication network. To configure the network baud rate, protocol type, serial formats, and self-address (BACnet only), press the enter button and scroll down to access the *Communication Menu* or use the SenvaSync App. Here you can set the following:

1. Protocol: Press enter to choose between BACnet MS/TP or Modbus RTU.
2. Device Address: Press or hold enter to increase address
3. Baud Rate: Press enter to choose between 9600, 19200, 38400, 57600, 76800, and 115200.
4. Parity: Press enter to choose between none, even, and odd
5. Stop Bits: Press enter to choose between 1 and 2.

Alarm Menu

If any alarm is present, a red exclamation mark will appear in the top right corner of the OLED. At any time during normal operation, user may scroll to the alarm menu to view active or previous alarm conditions. See Troubleshooting section for diagnostics.

OPERATION

NOTE: EMX-L has no screen, but may use the SenvaSync app to perform the same operations as noted here.

Once power is applied to the unit, the OLED screen will display the summary screen for a single load meter. To review more system measurements, the up and down arrows will cycle between the summary page, power readings, amperage readings, and voltage readings.

Power Setup

To set up the meter for the correct circuit, press the enter button  to enter the Metering Menu. The connection type 3-phase ABCN or ABC and 1-phase ABN or AB must be selected via menu, this must correspond to the wiring method used.

Wiring Config:

To set up the meter for the correct circuit, press the enter button to enter the Metering Menu. The connection type 3-phase ABCN or ABC and 1-phase ABN or AB must be selected via menu, this must correspond to the wiring method used. Press enter to confirm the circuit selection.

Current element selection:

The second required item in the metering menu is the current element selection. The options are CT and Rogowski Coil. Please select the option that matches the installed current element and press enter to confirm.

THE EMX ACCEPTS 0.333V CURRENT TRANSFORMERS ONLY.

1/3 Volt CT Set Up:

The third required item in the metering menu is the current scale. The units for this field are Amps per 0.333 volt. If a 0.333 volt CT is used this should be set to the primary side current of the CT.

TROUBLESHOOTING

See below table to diagnose alarms present on EMX.

Alarms	Corrective Action
Phase Loss	Check all phase voltages and current.
Low Power Factor	Sensor is reading PF<0.5. If not low PF, ensure voltage legs match with CTs.
Frequency Range	Frequency is below the minimum 45Hz or above the maximum 65Hz.
Voltage Range	Ensure system voltage does not exceed 600VAC.
Current Range	Replace with a larger amperage rated CT.
Neutral Current	Verify sizing and orientation of CTs.
Voltage Phase Loss	No detected voltage on one of more phases.
Pulse Config	Verify settings and consider increasing the Wh per pulse setting. User selected pulse settings violated the maximum duty cycle of the pulse output (50%), and the pulse duration setting was adjusted down by the firmware.
Pulse overrun	Verify pulse settings and consider increasing the Wh per pulse, or decreasing the pulse duration.
Meter Settings	Perform factory reset and recommission device.
Accumulator Loss	Power cycle or reset device. May loose up to 15 minutes of metered energy.
RTC Error ¹	Error with battery, call tech support
Logs Full ¹	Erase logs or allow log wrapping

¹ Alarm only applies to EMX, EMX-L does not have this alarm

If code is not shown in table above, please contact Senva technical support@senvainc.com or (866) 660-8864

Rogowski Coils

Rogowski Set Up:

Rogowski Coils are typically rated as XXX mV/kA at a certain frequency, this value must be converted before being programmed in. The conversion for current scale is

$$(1000A / XXX \text{ mV}) * 333\text{mV.}$$

For example a Rogowski Coil rated as 120mv/kA @60Hz would use a current scale of $(1000 / 120) * 333 = 2777.8$

For the Senva Rogowski Coils when Rogowski Coil is selected as the current element, the correct current scale will be selected.

If the Rogowski Coil is rated for 50Hz it will have to be scaled to get the correct scaling for a 60Hz system. To do this conversion the equation is as followed:

$$((XXX\text{mV/kA}) \div 50\text{Hz}) * 60\text{Hz}$$

BACnet/Modbus

The entire EMX family shares a common parameter list. For a complete list and description of each, please see the associated protocol guides: *EMX BACnet Protocol Guide* or *EMX Modbus Protocol Guide*.

DIMENSIONS

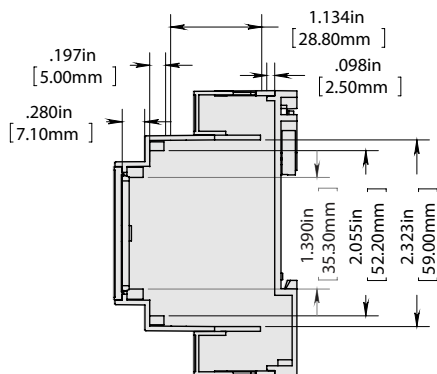
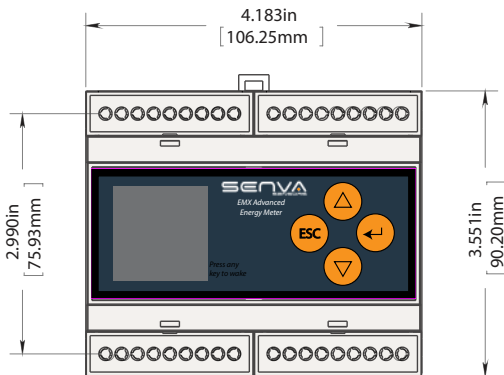

SPECIFICATION

Power Supply Input

Line/High voltage model	90-600VLL (+20%), 50/60Hz, 1-3 phase
Power Consumption	4W Typ.
Frequency Range	50/60 Hz

Output

RS-485	2-wire, BACnet MS/TP, Modbus RTU
Baud Rates	9600, 19200, 38400, 57600, 76800, 115200
RS-485 Loading	1/4 unit

EMX Wiring Requirements

Conductor gauge	12-24 AWG; Power terminals: 12-18 AWG
Terminal torque rating	0.37 ft-lb (0.50 N·m)

Pulse Inputs

Input Rating	3.5 ± 0.5 VDC, short circuit current is 10mA max
Pulse Active	<10 kOhms
Pulse Undefined	10-30 kOhms
Pulse Idle	>30 kOhms
Pulse Length	Accepts Pulses >10ms Rejects Pulses < 5ms

Pulse Output

Dual Outputs	Import & Export Energy Outputs, Alarm Status, and Pulse Input Echo
Type	Solid state dry contact
Alarm Configuration	N.O. or N.C.
Ratings	40VAC/DC, 300mA Max
Pulse scaling	0.01, 0.1, 1, 10, 100, 1k Wh/Pulse
Duration	10, 25, 50, 100, 250, 500 (ms)

Service Types

Configurations	1Ph, 2Ph, 3Ph Wye (4-Wire), 3Ph Delta (3-Wire)
Voltages	90VL-N through 600VL-L
Frequency	45-65 Hz
Measurement	CAT III

EMX Performance

Meter Accuracy	0.2% (ANSI C12.20 Class 0.2 standards), True RMS
State	Meets WA State Clean Building Bill
System Accuracy	1% for V, A, kW, kVAR, kVA

Operating Environment

Operating Temperature	-22 to 158°F (-30 to 70°C)
Storage Temperature	-40 to 158°F (-40 to 70°C)
Humidity	0-95% non-condensing
Environmental Rating	IP20; Front display IP40

EMX Meter Enclosure

Material	Polycarbonate/ABS
Dimensions	3.55" h x 4.18" w x 2.26" d

Compliance

Agency	UL Listed, cUL Listed, File E489498
Standards	RoHS, CE (Requires metal enclosure)