

Shark IQ ROBOT

SELF-EMPTY XL

Robot Vacuum

1000AE Series

OWNER'S GUIDE



IMPORTANT SAFETY INSTRUCTIONS

PLEASE READ CAREFULLY BEFORE USE • FOR HOUSEHOLD USE ONLY

If the charging cable plug does not fit fully into the outlet, reverse the plug. If it still does not fit, contact a qualified electrician. DO NOT force into outlet or try to modify to fit.

⚠ WARNING

To reduce the risk of fire, electric shock, injury, or property damage:

GENERAL WARNINGS

When using an electrical appliance, basic precautions should always be followed, including the following:

1. Robotic vacuum cleaner consists of a robotic vacuum and charging base with power supply. These components contain electrical connections, electrical wiring, and moving parts that potentially present risk to the user.
2. Before each use, carefully inspect all parts for any damage. If a part is damaged, discontinue use.
3. Use only identical replacement parts.
4. This robotic vacuum cleaner contains no serviceable parts.
5. Use only as described in this manual. **DO NOT** use the robotic vacuum cleaner for any purpose other than those described in this manual.
6. With the exception of filters, **DO NOT** expose any parts of the robotic vacuum cleaner to water or other liquids.

USE WARNINGS

7. This appliance can be used by persons with reduced physical, sensory or mental capabilities or lack of experience and knowledge if they have been given supervision or instruction concerning use of the appliance in a safe way and understand the hazards involved.
 - a) Children shall not play with the appliance.
 - b) Cleaning and user maintenance shall not be made by children without supervision.
8. Always turn off the robotic vacuum cleaner before inserting or removing the filter or dust bin.
9. **DO NOT** handle plug, charging base, charging cable, or robotic vacuum cleaner with wet hands. Cleaning and user maintenance shall not be made by children without supervision.
10. **DO NOT** use without robot dust bin and filters in place.

11. **DO NOT** damage the charging cord:
 - a) **DO NOT** pull or carry charging base by the cord or use the cord as a handle.
 - b) **DO NOT** unplug by pulling on cord. Grasp the plug, not the cord.
 - c) **DO NOT** close a door on the cord, pull the cord around sharp corners, or leave the cord near heated surfaces.
12. **DO NOT** put any objects into nozzle or accessory openings. **DO NOT** use with any opening blocked; keep free of dust, lint, hair, and anything that may reduce airflow.
13. **DO NOT** use if robotic vacuum cleaner airflow is restricted. If the air paths become blocked, turn the vacuum cleaner off and remove all obstructions before turning on the unit again.
14. Keep nozzle and all vacuum openings away from hair, face, fingers, uncovered feet, or loose clothing.
15. **DO NOT** use if robotic vacuum cleaner is not working as it should, or has been dropped, damaged, left outdoors, or dropped into water.
16. **DO NOT** place vacuum cleaner on unstable surfaces.
17. **DO NOT** use to pick up:
 - a) Liquids
 - b) Large objects
 - c) Hard or sharp objects (glass, nails, screws, or coins)
 - d) Large quantities of dust (drywall dust, fireplace ash, or embers). **DO NOT** use as an attachment to power tools for dust collection.
 - e) Smoking or burning objects (hot coals, cigarette butts, or matches)
 - f) Flammable or combustible materials (lighter fluid, gasoline, or kerosene)
 - g) Toxic materials (chlorine bleach, ammonia, or drain cleaner)

18. **DO NOT** use in the following areas:
 - a) Wet or damp surfaces
 - b) Outdoor areas
 - c) Spaces that are enclosed and may contain explosive or toxic fumes or vapors (lighter fluid, gasoline, kerosene, paint, paint thinners, mothproofing substances, or flammable dust)
 - d) Near fireplaces with unobstructed entrances.
 - e) In an area with a space heater.
 19. Turn off the robotic vacuum cleaner before any adjustment, cleaning, maintenance or troubleshooting.
 20. Allow all filters to air-dry completely before replacing in the robotic vacuum cleaner to prevent liquid from being drawn into electric parts.
 21. **DO NOT** modify or attempt to repair the robotic vacuum cleaner or the battery yourself, except as indicated in this manual. **DO NOT** use the vacuum if it has been modified or damaged.
 22. To reduce the risk of electric shock, this appliance has a polarized plug (one blade is wider than the other). This plug will fit in a polarized outlet only one way. If the plug does not fit fully in the outlet, reverse the plug. If it still does not fit, contact a qualified electrician to install the proper outlet. Do not change the plug in any way.
 23. In case the self-empty base has a thermal shutoff the unit needs to have a hard power reset to restart.
- ### BATTERY USE
24. The battery is the power source for the vacuum. Carefully read and follow all charging instructions.
 25. To prevent unintentional starting, ensure the vacuum is powered off before picking up or carrying the vacuum. **DO NOT** carry the appliance with your finger on the power switch.
 26. Use **ONLY** the Shark® self-empty base XDCKRV1300 and use only battery RVBAT850. Use of batteries or battery chargers other than those indicated may create a risk of fire.
 27. Keep the battery away from all metal objects such as paper clips, coins, keys, nails, or screws. Shorting the battery terminals together increases the risk of fire

or burns.

28. Under abusive conditions, liquids may be ejected from the battery. Avoid contact with this liquid, as it may cause irritation or burns. If contact occurs, flush with water. If liquid contacts eyes, seek medical help.
29. Robotic vacuum cleaner should not be stored, charged, or used at temperatures below 50°F (10°C) or above 104°F (40°C). Ensure the battery and vacuum have reached room temperature before charging or use. Exposing the robot or battery to temperatures outside of this range may damage the battery and increase the risk of fire.
30. **DO NOT** expose the robotic vacuum cleaner or battery to fire or temperatures above 265°F (130°C) as it may cause explosion.

BOTBOUNDARY® STRIPS

31. **DO NOT** put BotBoundary strips underneath carpet or rugs.
32. **DO NOT** place BotBoundary strips on top of one another.
33. Always use BotBoundary strips around reflective flooring and surfaces.
34. BotBoundary strips should always be used near carpeted stairs.
35. **DO NOT** place BotBoundary strips within 10 feet of the base.
36. For your robot's cliff sensors to work properly, all runners, rugs, or carpets must be eight inches from any stairs (or it must be continuous and extend over the edge of the stairs). If a runner, rug or carpet edge that is less than eight inches from the stairs cannot be moved, you must use a BotBoundary strip to block off the stairs.

SAVE THESE INSTRUCTIONS

For the latest warnings and cautions, go to sharkclean.com/robothelp

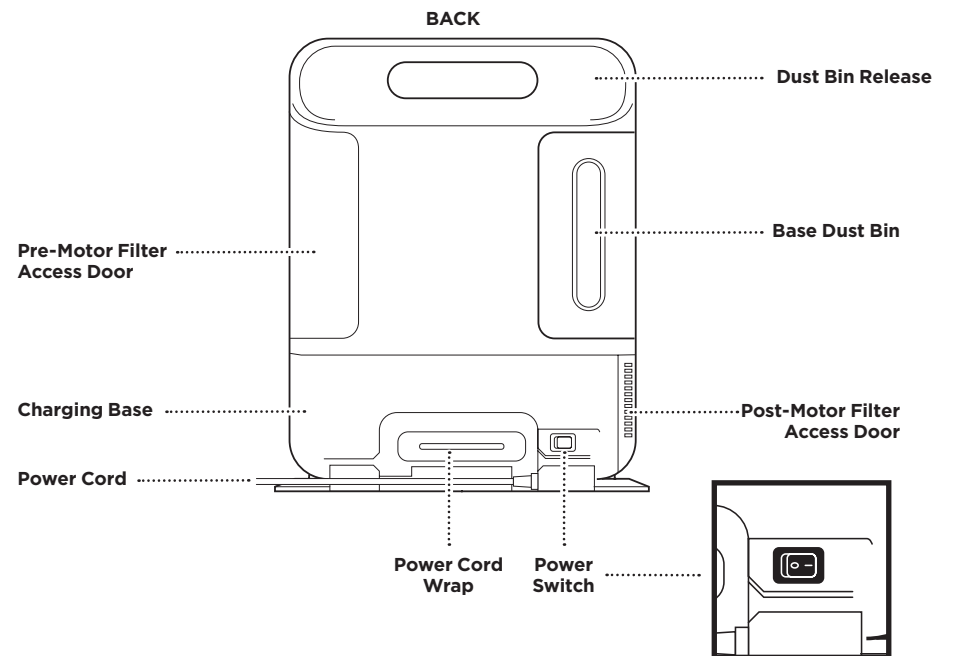
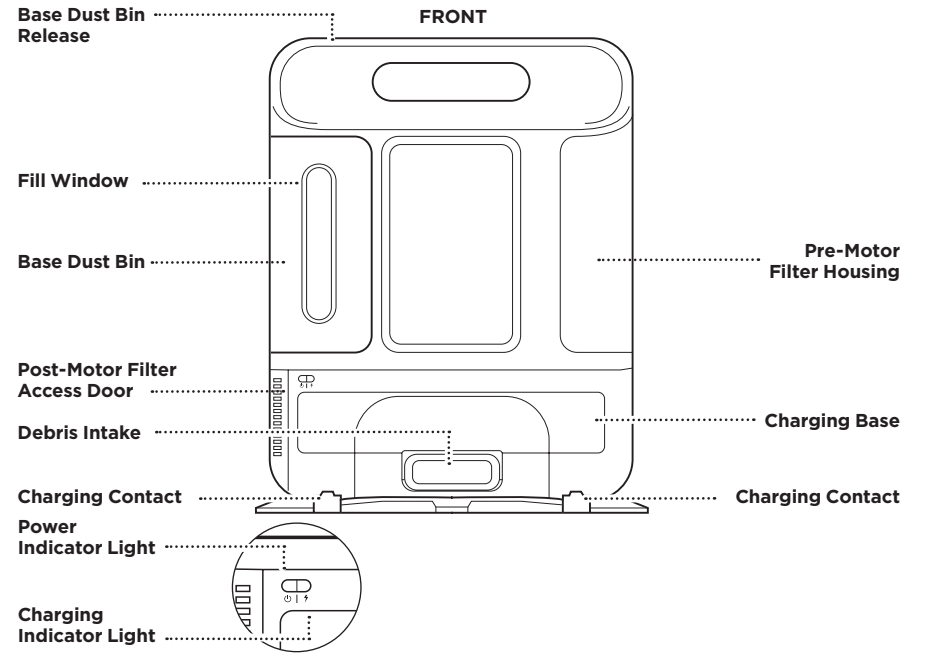
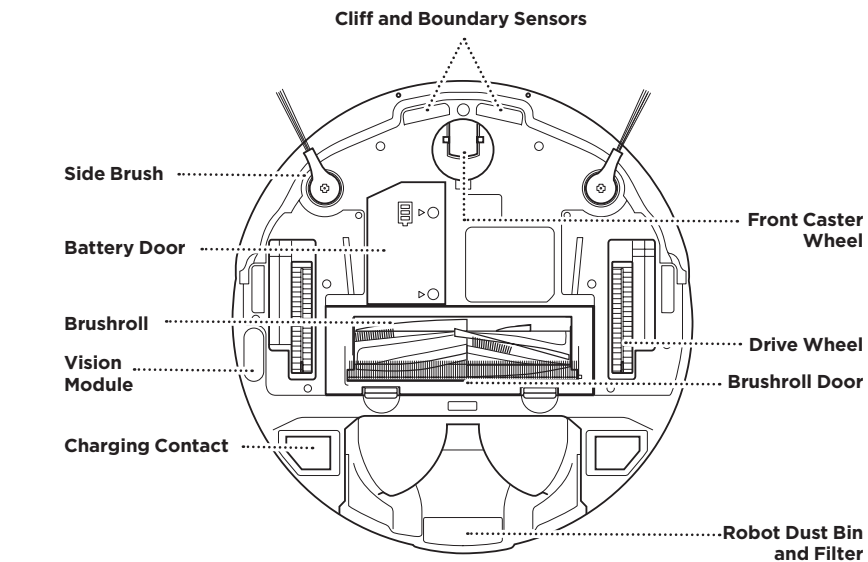
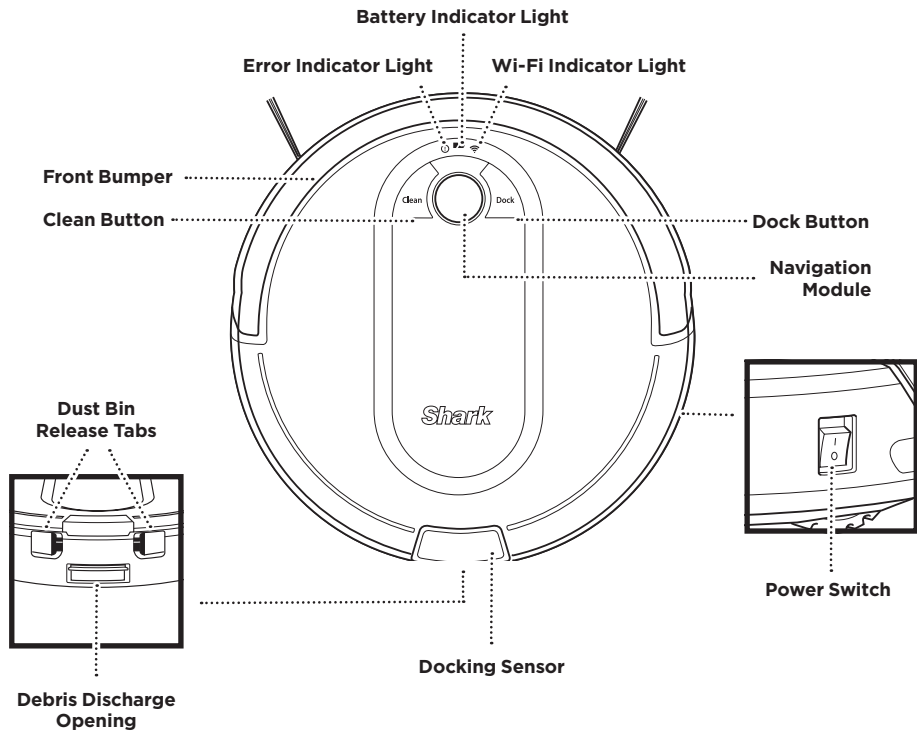

BASE SETUP

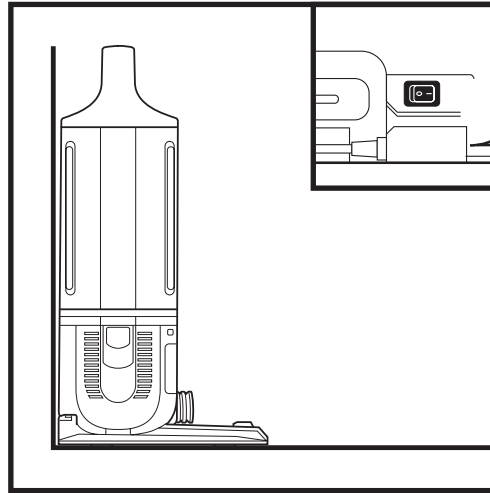
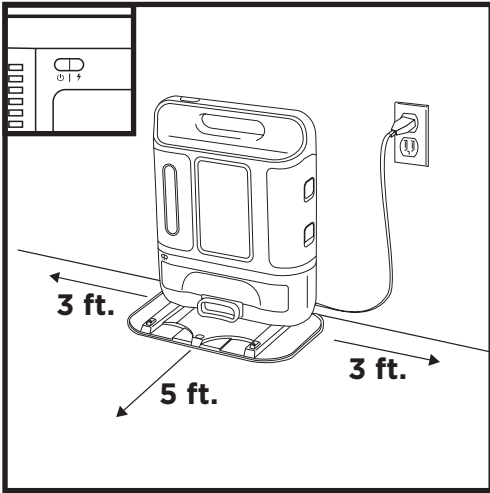

The **Self-Empty Base** charges your robot and holds dirt and debris from up to 45 days of cleaning.

- Select a permanent location for the base. Every time you move the base, your robot will have to completely re-map your house.
- Choose a level surface in a central area. Remove protective film from base.
- Place the base with its back against the wall, in an area with a good Wi-Fi signal.
- Set up the base on bare floor.
- Remove any objects closer than 3 feet from the sides of the base, or closer than 5 feet from the front.
- Plug in the **Charging Cord**, and turn on the **Power Switch** on the back of the base. When the base is plugged in and the power switch is turned on, the **GREEN Power Indicator Light** \odot on the base will illuminate.

NOTE: Do not place base against heating elements or baseboards, or in direct sunlight.

NOTE: The robot will make a loud noise when it empties its debris into the base. This is normal and not a cause for concern.

INSTALLING THE SIDE BRUSHES

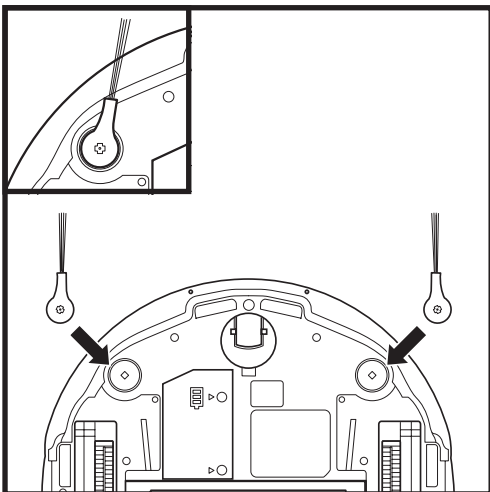

Snap the 2 included **Side Brushes** onto the square pegs on the bottom of the robot.

CHARGING

IMPORTANT: The Shark IQ Robot® has a pre-installed rechargeable battery. Charge the battery completely before using the robot. It may take up to 6 hours to fully charge.

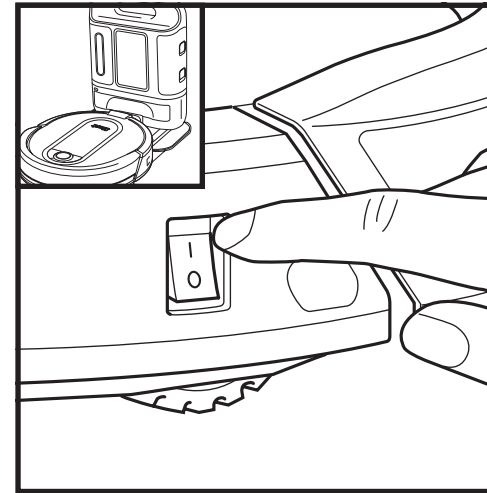

To charge, place the robot with its **BACK** side against the base. The metal **Charging Pads** on the bottom of the robot must be touching the **Charging Contacts** on the base. Make sure the power switches on **BOTH** the robot and the base are turned to the (I) ON position.

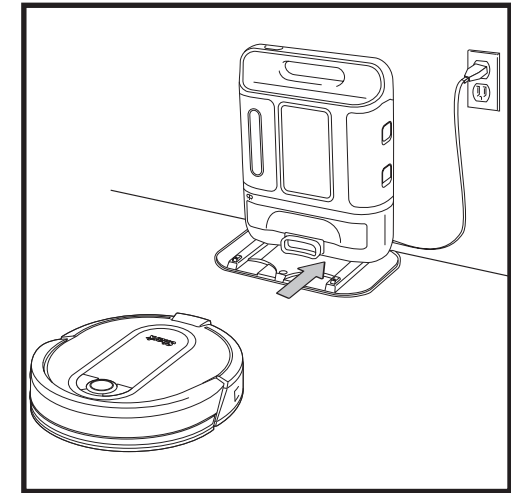

When charging begins, the robot will beep. The **BLUE Charging Indicator Light** on the base will **PULSE**, and the **Battery Indicator Light** on the robot will flash blue. When the robot is fully charged, the battery light on the robot and the blue charging indicator light on the base will illuminate steadily.

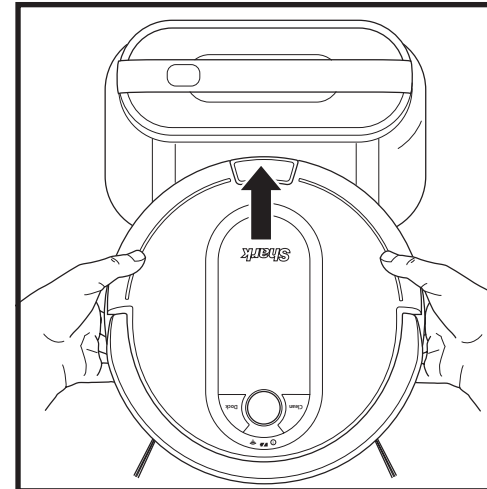

When the cleaning cycle is complete, or if the battery is running low, the robot will search for the base. If your robot doesn't return to the base, its charge may have run out. Make sure that all the protective film has been removed from the base, and recharge the robot

NOTE: When manually placing the robot on the base, make sure the charging contacts on the bottom of the robot are touching the ones on the base and the robot's dust bin is touching the debris intake on the base. When the robot is fully charged, the battery light on the robot and the indicator light on the base will both turn solid blue.

NOTE: When picking up the robot be careful not to place fingers between the bumper and the base of the robot.

ROBOT BATTERY INDICATOR LIGHT

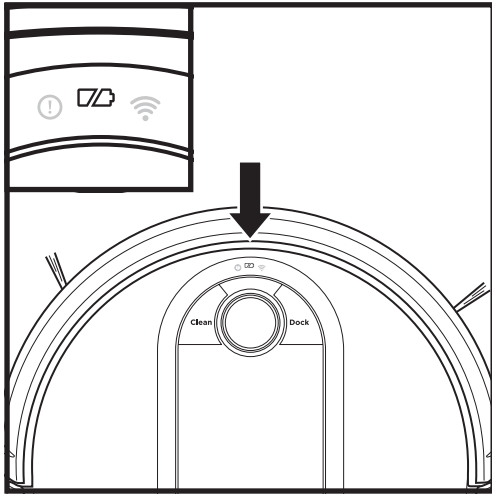

ROBOT BATTERY INDICATOR LIGHT

In Use



While Charging (Blue)



No Charge or Off



The battery indicator light on the robot shows how much charge is remaining. When the robot is charging, the battery light will flash blue. When charging is complete, the light will illuminate steadily in blue.

NOTE: If the battery indicator light on the robot is blinking red, there is not enough charge for the robot to return to the base. Manually place the robot on the base.

BASE INDICATOR LIGHTS

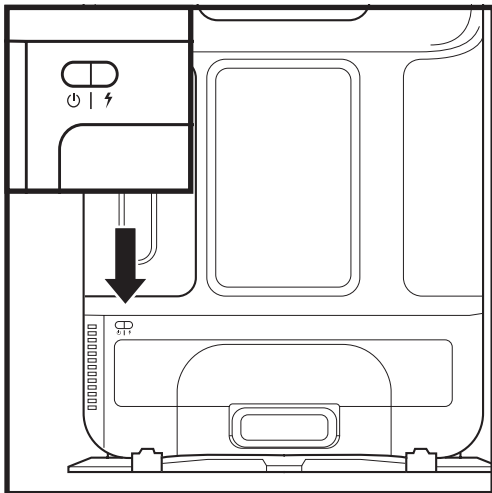

Power Indicator Light



Charging Indicator Light



There are 2 indicator lights on the front of the base, the green power indicator light and the blue charging indicator light. When the base is plugged in and the power switch is turned on, the **GREEN** power light  will illuminate. When the robot is charging on the base, the **BLUE** light will pulse. When charging is complete, the blue light will illuminate steadily.

BUTTONS AND INDICATOR LIGHTS

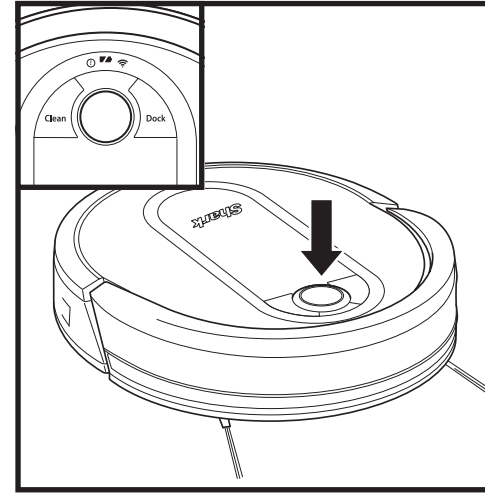

CHARGE INDICATOR LIGHTS
Display the amount of charge remaining in the battery.



“!” ERROR INDICATOR
See Troubleshooting section for full list of error codes.



WI-FI INDICATOR
Blue light: connected to Wi-Fi.
Red light: not connected.
Flashing blue: setup mode.
No light: not set up yet.

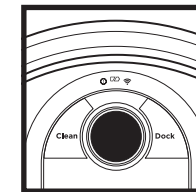

NAVIGATION MODULE
Please keep clear and do not cover.
Upward-facing sensor aids advanced navigation.

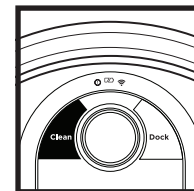

CLEAN BUTTON

Press to begin a cleaning session. Press again to stop.

RECHARGE & RESUME

Press and hold the Clean button for 15 seconds to turn Recharge & Resume ON or OFF.

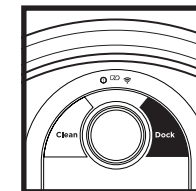

DOCK BUTTON

Press to stop cleaning and send robot back to the charging base.

EVACUATE & RESUME

Press and hold the Dock button for 15 seconds to turn Evacuate & Resume ON or OFF.

The Recharge & Resume function is turned OFF by default. Turn ON Recharge & Resume for complete coverage if your home's floor plan is bigger than 1500 sq. ft. Your robot will return to the base, recharge, and can pick up cleaning where it left off.

Turn ON Evacuate & Resume for homes with pets. Your robot will return to the base to empty the dust bin after **30 minutes**, then resume cleaning where it left off.

NOTE: If your floor plan is smaller than 1000 sq. ft., we recommend that you **DO NOT** use the Evacuate & Resume function.

PREP YOUR HOME

Your robot uses an array of sensors to navigate around walls, furniture legs, and other obstacles while it cleans. To prevent the robot from bumping into objects or navigating to areas you don't want it to, use the included BotBoundary® strips. For best results, prepare your home as indicated below, and schedule a daily cleaning to ensure all floor areas are regularly maintained.

NOTE: Scheduling is one of many features that are only available in the app.



OBSTRUCTIONS

Clear cords and small objects from floors and open interior doors to ensure a complete map of your home.



AVOID MOVING THE ROBOT OR BASE

While your robot is cleaning, do not pick it up and move it, or move the charging base—this will impact the robot's ability to map your home.



THRESHOLDS

Your robot may have some trouble clearing thresholds higher than an inch. Block off high thresholds with the included BotBoundary strips.

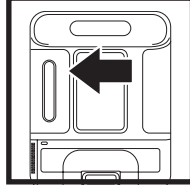

CHECK BASE FILL LEVEL

During the first few weeks, your robot will empty more debris than usual. Check the fill level regularly. The dust bin is designed to hold up to 45 days' worth of debris, but home environments vary, and the bin may fill up quicker in some homes.

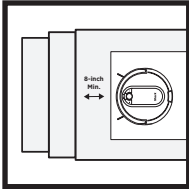

STAIRS

Your robot's cliff sensors will prevent it from falling off ledges. For the cliff sensors to work properly, all runners, rugs, or carpets must be at least 8 inches from any stairs (or extend over the edge of the stairs.)

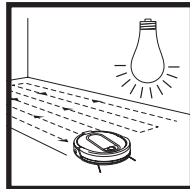

LIGHTING CONDITIONS

For best results, run your robot in well-lit conditions. If you run your robot at night, keep the lights on in the areas to be cleaned.

BOTBOUNDARY® STRIPS

PREPPING YOUR HOME USING BOTBOUNDARY STRIPS

Use the BotBoundary strips to quickly and easily create no-go zones to keep your robot out of the areas you would like it to avoid. These may include:

- Near power cords
- In front of thresholds higher than an inch

USAGE INSTRUCTIONS

1. You can cut BotBoundary strips to shorten them as needed. (**18-inch minimum**) If cutting a strip, make sure it's still long enough to cover the entire area you need to block off. Gaps may cause BotBoundary strips to malfunction.
2. Make sure each BotBoundary strip lies completely **flat** against the floor, with no overlapping. **NOTE: DO NOT** place BotBoundary strips on top of one another.
3. For best results, place the strips between fixed objects like furniture legs or door frames, or make a closed loop around an obstacle.

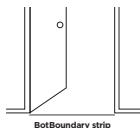
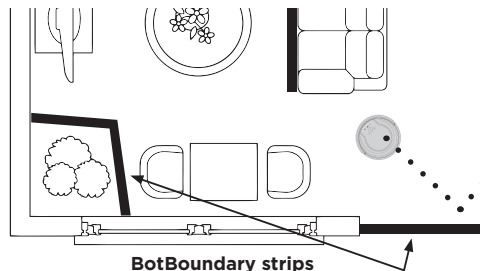
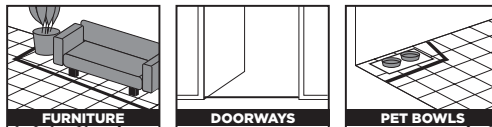

MAPPING AND NAVIGATION

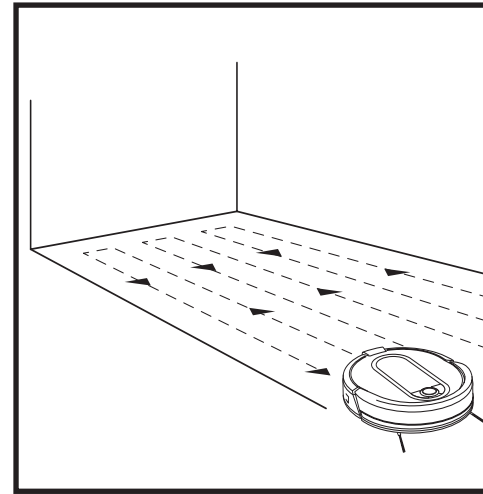

As it cleans, your robot will create a map of your home. It may take several cleanings for the robot to finish its mapping. Once mapping is complete, an **Interactive Map** of your floor plan will be available on the app.

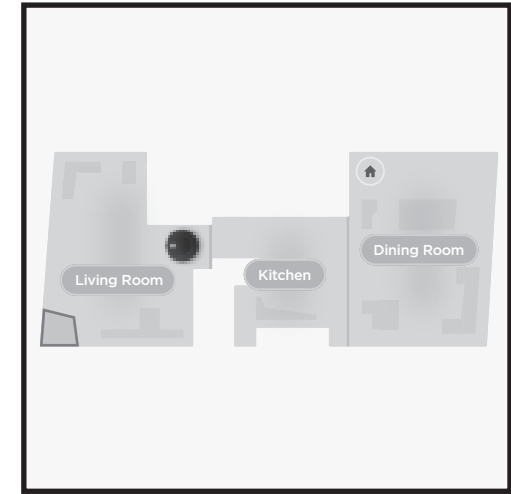

The interactive map in the app allows you to name rooms, then select which rooms to clean, and send the robot to immediately clean one specific location.

As cleanings continue, the robot will update and refine its path to provide optimized cleaning coverage. After each use, a cleaning report will be available in the app.

MANUAL CLEANING MODE

To manually start a cleaning cycle, press the **Clean** button on the robot or on the mobile app. To stop the robot before it finishes cleaning and automatically returns to the base, press the Dock button.

NOTE: Be sure to charge the robot completely before its first cleaning so that it can explore, map, and clean as much of your home as possible. It may take up to 6 hours to fully charge the robot.

NOTE: Avoid picking up and moving the robot or base. If either are relocated, the robot may not be able to follow its intelligent cleaning path, or find its way back to the base. If the robot is picked up or moved for any reason, it should be returned to within 6 inches of its last location.

USING THE SHARK IQ ROBOT®

Please visit sharkclean.com/app or call 1-888-228-5531 for answers to all your app questions.

USING THE SHARKCLEAN® APP AND VOICE CONTROLS

Get the most out of your Shark iQ Robot® with these app features:

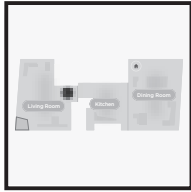

- **Interactive Map**
Your robot knows where it is in your home. Identify rooms for Room Select.
- **Room Select**
Immediately send your robot directly to any room on that floor.
- **Recharge and Resume**
Use Recharge and Resume to help ensure complete, multi-room coverage in your home.

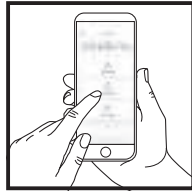

- **Scheduling**
Set whole-home cleanings for any time, any day.
- **Control From Anywhere**
Wherever you are, you're in control of your robot.
- **Cleaning Reports**
Each time your robot cleans, your app will generate a cleaning report.
- **Volume Control**
You can adjust the volume level of your robot's audio notifications.

Search for **SharkClean** in the app store and download the app to your iPhone™ or Android™.



SETTING UP VOICE CONTROL WITH THE GOOGLE ASSISTANT OR AMAZON ALEXA

Visit sharkclean.com/app for setup instructions which include how to enable Shark Skill for Amazon Alexa and using with Google Assistant.

Google Assistant:

- “OK Google, tell Shark to start cleaning.”
- “OK Google, tell Shark to pause my robot.”
- “OK Google, tell Shark to send my robot to the dock.”

Amazon Alexa:

- “Alexa, tell Shark to start cleaning.”
- “Alexa, tell Shark to pause my robot.”
- “Alexa, tell Shark to send my robot to the dock.”

WI-FI TROUBLESHOOTING

- To use the app, your phone must be connected to a **2.4 GHz** network. The app will only work on a 2.4 GHz network.
- Typical home Wi-Fi networks support both 2.4 GHz and 5 GHz.
- Do not use a VPN or a proxy server.
- Make sure Wi-Fi isolation is turned off on the router.
- If you cannot connect, call 1-888-228-5531.

STILL CAN'T CONNECT?

- **Restart your phone**
 - Turn off phone, wait a few minutes, then turn it back on and connect to Wi-Fi.
- **Reboot your robot**
 - Make sure the power switch on the back of the BASE is in the ON position.
 - Press the power switch on the side of the ROBOT to the OFF position. Wait 10 seconds, then press it again to turn power back ON.
- **Reboot your router**
 - Unplug the router power cable for 30 seconds, then plug it back in. Allow several minutes for your router to reboot completely.

ERROR CODE	PROBLEM
! (RED) + Wi-Fi indicator (RED Flashing)	Wrong password for Wi-Fi
! (Flashing red) + Wi-Fi (RED)	SSID cannot be found, try connecting again
! + Wi-Fi (Flashing RED alternately)	Wrong user name or password for your Shark account
! + Wi-Fi (Flashing RED at the same time)	Cannot connect to Wi-Fi

MAINTENANCE

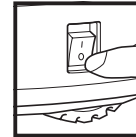

CAUTION: Turn off power before performing any maintenance.

EMPTYING THE ROBOT DUST BIN

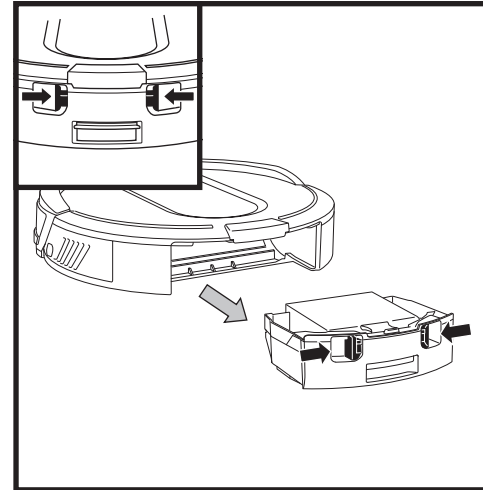

Press the **Dust Bin Release Tabs** and slide out the dust bin.

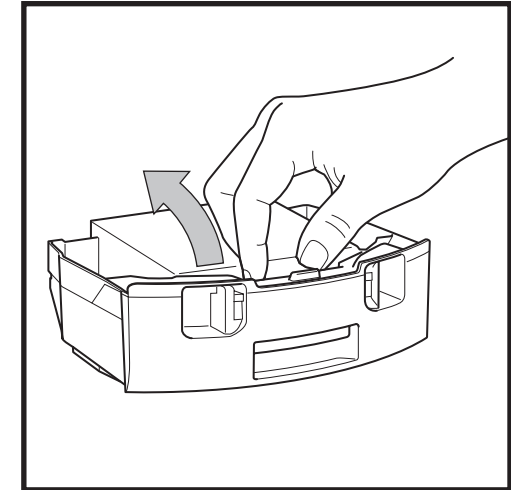

To avoid spills, be sure to hold the dust bin in an upright position. Pinch and lift to open the lid.

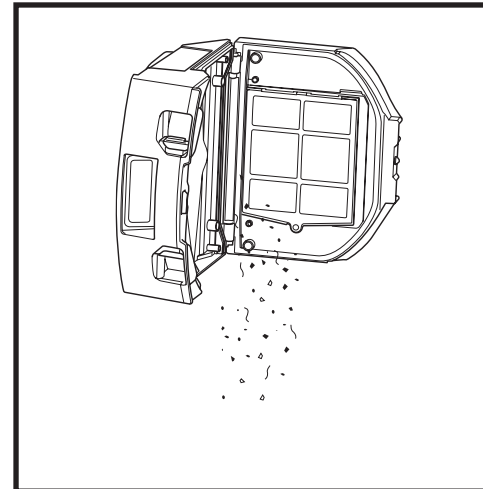

Empty debris and dust into trash.

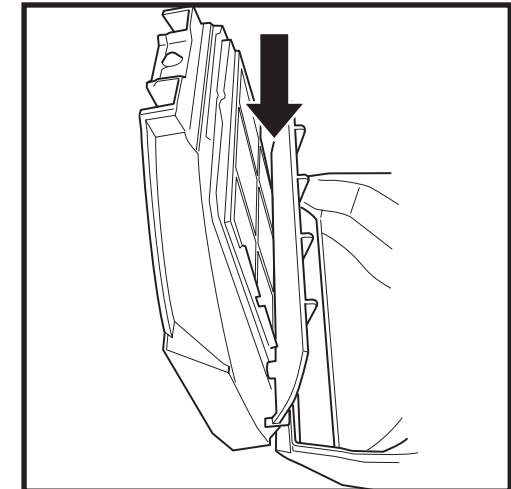

Look between the filter and plastic shield and make sure there is no debris buildup. Remove and clean any debris buildup as needed with a dry cloth or soft brush.

MAINTENANCE

EMPTYING THE BASE DUST BIN

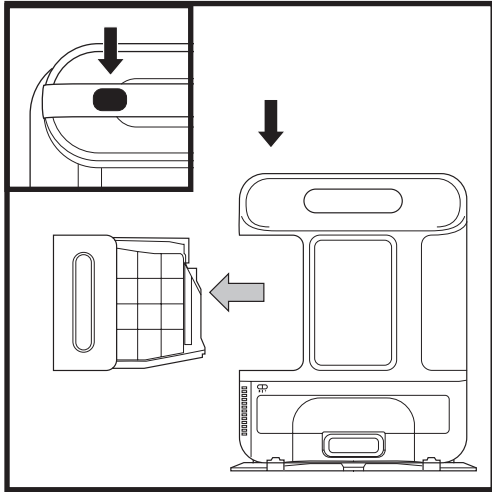

The **Base Dust Bin** holds up to 45 days' worth of dust and debris. Empty the bin when the debris level approaches the max fill line.

To detach it, press the **Release** button on top of the handle, then slide out the bin.

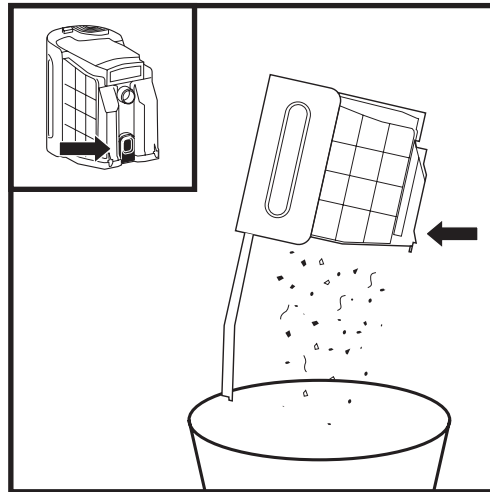

To empty the bin, hold it over a trash can and press the **Empty** button on the side.

MAINTENANCE

CLEANING AND REPLACING THE ROBOT FILTER

For optimal suction power, regularly clean and replace the filter inside the robot's dust bin. See sharkaccessories.com for replacement filters.

IMPORTANT: DO NOT use water to clean the robot filter.

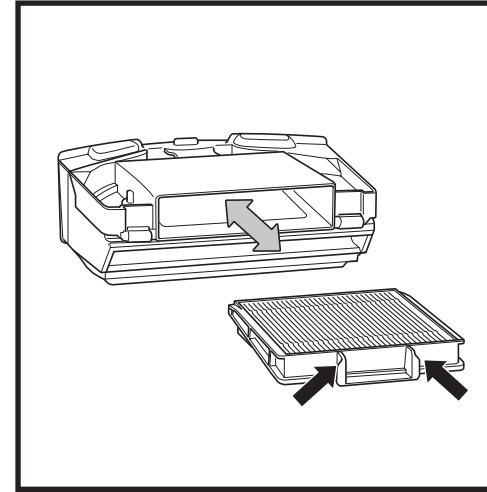

Pull filter out of the dust bin by the tabs.

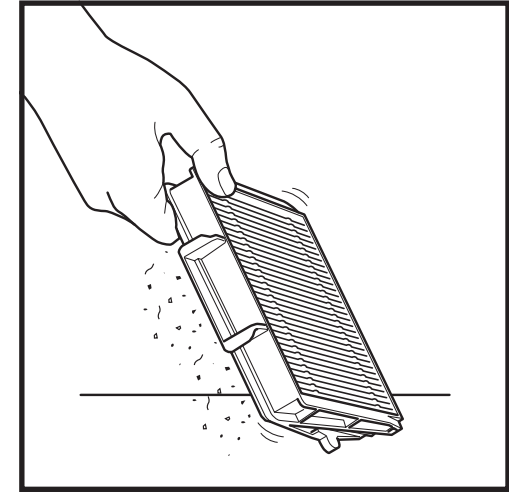

Lightly tap the filter to remove dust and debris.

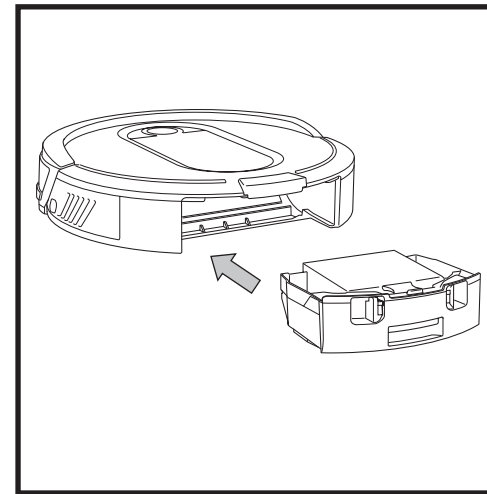

Reinsert the filter into the robot dust bin, then slide the dust bin back into the robot.

NOTE: Make sure to insert the dust bin completely, until it clicks into place.

MAINTENANCE

CLEANING AND REPLACING THE BASE FILTERS

For best results, regularly clean and replace the filters in the base.

To clean filters, rinse with cold water **ONLY** to prevent damage from cleaning chemicals. Allow all filters to air-dry for at least 24 hours before reinstalling them to prevent liquid from being drawn into electric parts.

IMPORTANT: DO NOT use soap when cleaning the filters.

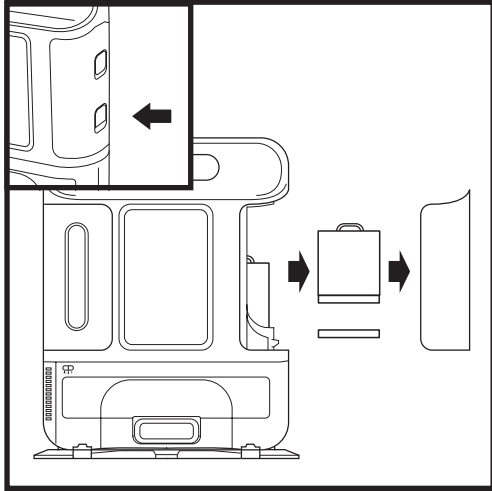

CLEAN PRE-MOTOR FILTERS ONCE A MONTH

To access the pre-motor filters, remove the cover on the side of the base. Press both slots at the same time and pull off the cover. Lift out the foam filter by the handle, and then remove the felt filter underneath.

Tap the filters clean over the trash, then rinse them with cold water only, as soap or other cleaners may damage them. Allow the filters to air-dry for 24 hours before reinstalling.

The filters must be installed correctly for the base to work properly. Reinsert the felt filter first, then the foam filter. To reattach the cover, align the bottom of the cover with the slot on the base and press firmly until it clicks into place.

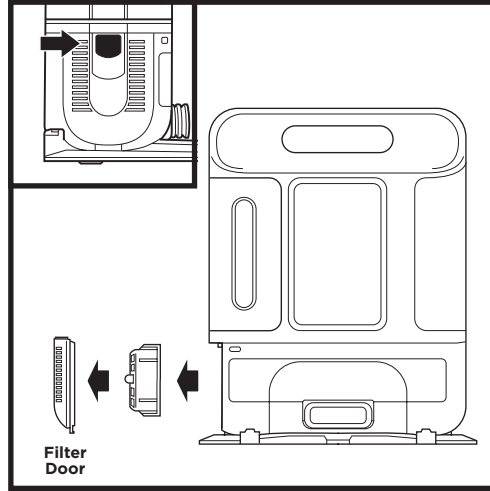

CLEAN POST-MOTOR FILTER EVERY YEAR

Press the button at the top of the **Filter Door**, then tilt the door and lift it off. Remove the **Post-Motor Filter** from the base. To reinstall the post-motor filter, insert it into the base and replace the filter door.

NOTE: The pre-motor foam and felt filters should be replaced every 2.5 years. The post-motor filter should be replaced every 3 years.
NOTE: Clean the mesh filter inside the dust bin with a small brush once a month.

MAINTENANCE

SELF-CLEANING BRUSHROLL

The **Self-Cleaning Brushroll** removes debris over time as it cleans. If some debris remains wrapped around the brushroll, continue cleaning to allow the brushroll to remove it.

If some debris remains on the brushroll after continued cleaning, follow the steps below to remove it.

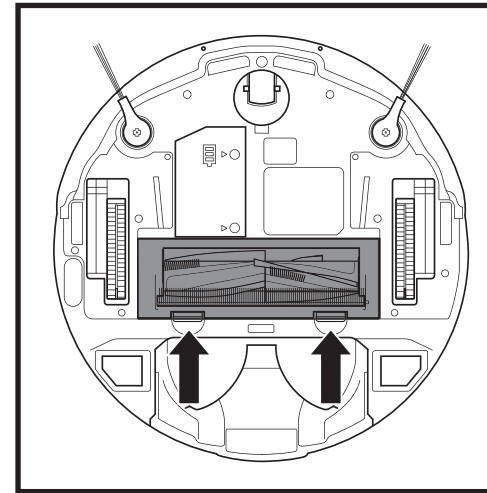

To access the brushroll, push up on the tabs on the brushroll access door, then lift off the door.

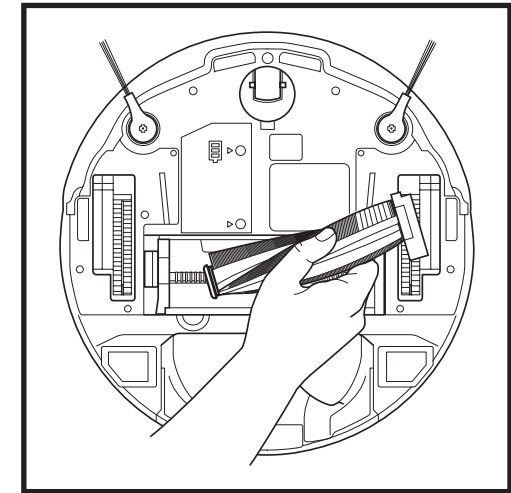

Lift out the brushroll, and clean off any debris. Reinstall the brushroll, inserting the flat end first. Close the brushroll access door and press down until both sides click into place.

NOTE: When cutting away debris, be sure not to cut the brushroll.
NOTE: Replace brushroll every 6 to 12 months, or when visibly worn. See sharkaccessories.com for replacement parts.

MAINTENANCE

CLEANING SENSORS AND CHARGING PADS

CLEAN SENSORS AND CHARGING PADS AS NEEDED. With a dry cloth, gently dust off the sensors and pads located on the bottom of the robot and on the base.

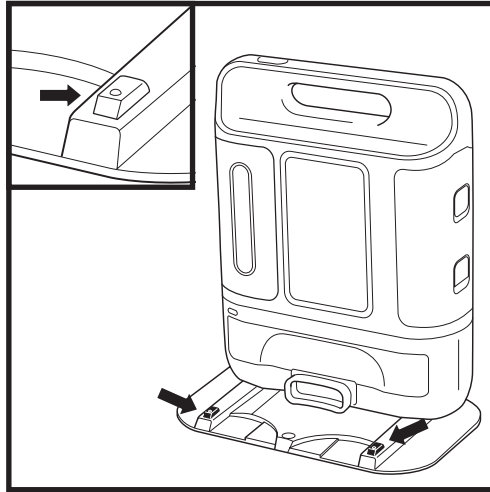
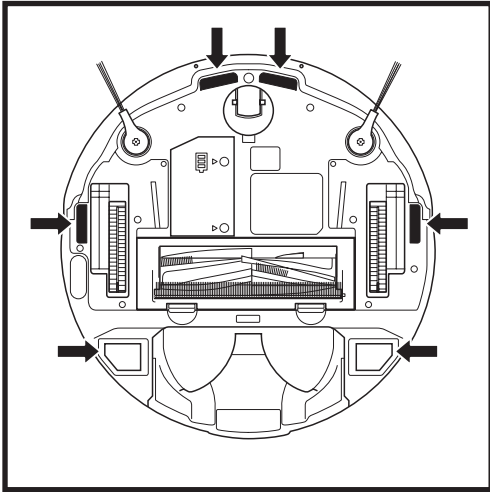

IMPORTANT: The robot uses cliff sensors to avoid stairs and other steep drops. Sensors may work less effectively when they are dirty. For best results, clean sensors regularly.

CLEANING SIDE BRUSHES

CLEAN SIDE BRUSHES AS NEEDED.

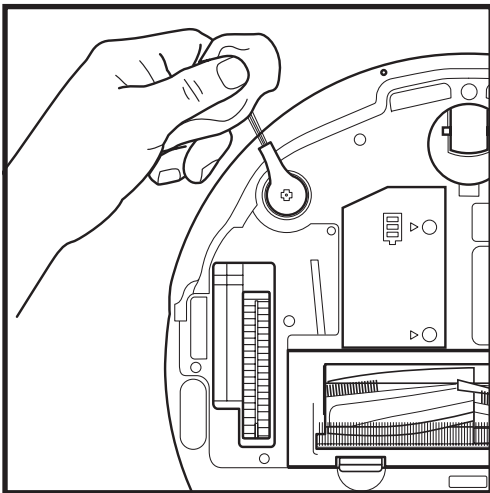

Carefully unwind and remove any string or hair wrapped around brushes.
Gently wipe brushes with a dry cloth. To reinstall, snap the brushes over the pegs. Spin the brushes manually to make sure they are installed correctly.

NOTE: Remove and replace any side brushes that are bent or damaged. To remove a brush, lift it off its peg.

MAINTENANCE

CLEANING THE WHEELS

REMOVE AND CLEAN THE FRONT CASTER WHEEL AS NEEDED. See sharkaccessories.com for replacement parts.

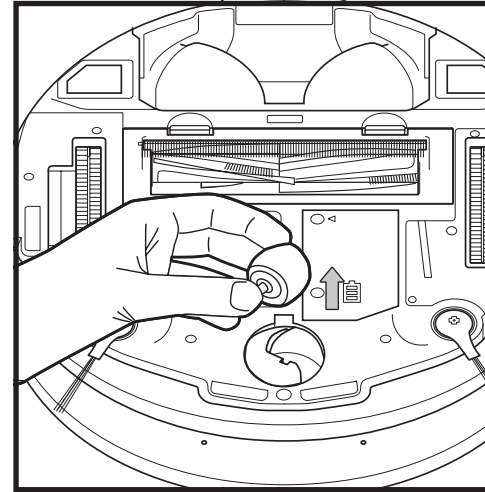

Pull the **Front Caster Wheel** from its housing and remove any debris buildup.

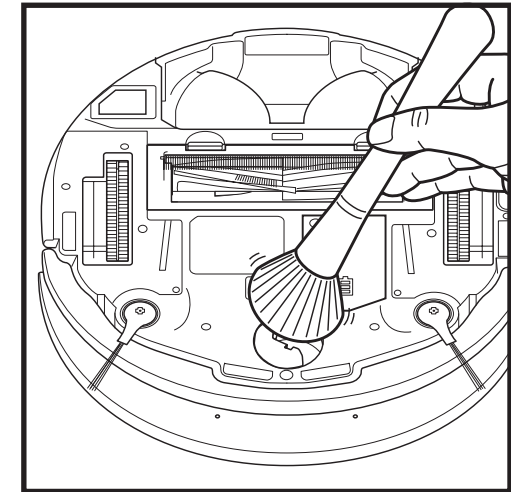

Clean the wheel housing, then reinsert the caster wheel.

NOTE: Tools may be required to pry off front caster wheel.
NOTE: Brush not included.

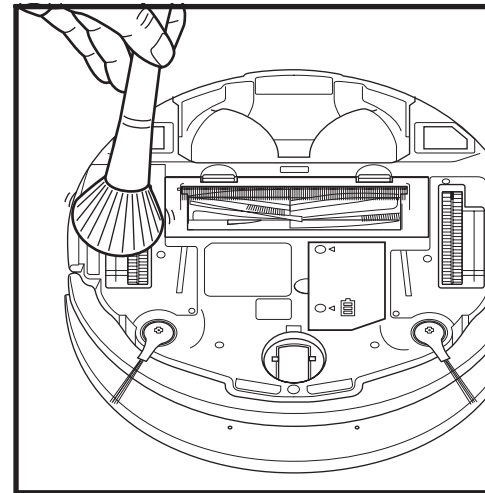

Periodically clean the drive wheels and the housing around them. To clean, rotate each drive wheel while dusting.

REPLACEMENT PARTS

REPLACEMENT PARTS: ROBOT

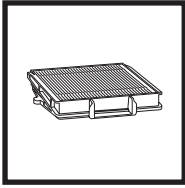

Filter

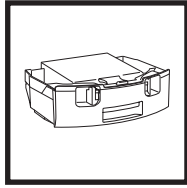

Robot Dust Bin

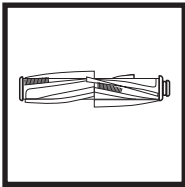

Brushroll

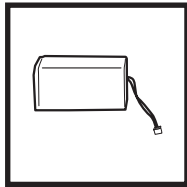

Battery

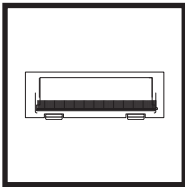

Brushroll Door

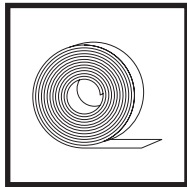

BotBoundary®

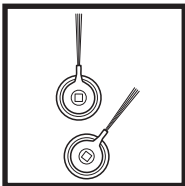

Side Brushes

REPLACEMENT PARTS: BASE

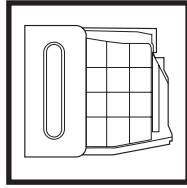

Base Dust Bin

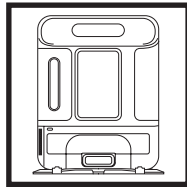

Self-Empty Base

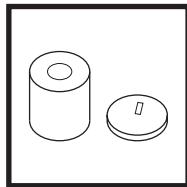

Pre-Motor Foam & Felt Filter Kit

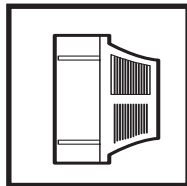

Replacement Post-Motor Filter

NOTE: To order replacement parts and filters, visit sharkaccessories.com.

MAINTENANCE

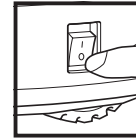

CAUTION: Turn off power before performing any maintenance.

TROUBLESHOOTING

If any error lights are illuminated or flashing on your Shark iQ Robot®, see the error code chart below:

ERROR CODE	ERROR NUMBER	SOLUTION
CLEAN (RED) flashing	10	Robot may be stuck on an obstacle. Move robot to a new location on a level surface.
DOCK (RED) flashing	6	Front bumper may be jammed. Clean the bumper and make sure it moves in and out freely.
CLEAN (BLUE) + DOCK (RED) solid	14	BotBoundary® error. Move your robot to a flat surface away from the magnetic boundary strip and try cleaning again.
CLEAN (RED) + DOCK (BLUE) flashing	7	Cliff sensor error. Move your robot to a new location and clean its cliff sensors.
CLEAN (RED) + DOCK (RED) flashing	9	Robot dust bin needs to be reinstalled. Insert the dust bin until it clicks in place.
DOCK (RED) + ! (RED) flashing	2	Side brush is stuck. Remove any debris from around the side brushes so they move freely.
CLEAN (RED) + DOCK (RED) + ! (RED) flashing	2	A drive wheel is stuck. Clean the wheels and remove any debris wrapped around the axles so they can move freely.
CLEAN (RED) + DOCK (BLUE) alternating	16	Robot is stuck. Move your robot to a new location and make sure the front bumper moves in and out freely.
CLEAN (BLUE) + ! (RED) flashing	2	Blockage in brushroll. Remove any debris from around the brushroll so that it can spin freely.
CLEAN (RED) + DOCK (BLUE) + ! (RED) flashing	21	Robot has encountered an error while booting. Please turn the power off and back on.
CLEAN (BLUE) + DOCK (RED) flashing	23	Make sure your base indicator light turns blue to confirm your robot is placed on the base correctly.
BATTERY ICON (RED) flashing	24	Battery is critically low and needs recharging. Please pick up your robot and place it on the base. Make sure the base indicator light turns blue to confirm your robot is placed on the base correctly.
CLEAN (RED) + ! (RED) alternating	2	Blockage in brushroll. Remove any debris from around the brushroll so that it can spin freely.
DOCK (RED) FLASHING + ! (RED) solid	26	Blockage in dust bin. Check base and robot dust bin for clogs. Clear any debris and reinstall the dust bin, ensuring that it clicks into place.
DOCK (BLUE) + ! (RED) flashing	24	Robot has encountered an error while charging. Please make sure you are using the correct power cord for the base.
CLEAN (RED) + ! (RED) flashing	3	Suction motor failure. Remove and empty the dust bin, clean the filters, and remove blockages.
CLEAN (BLUE) + DOCK (RED) + ! (RED) flashing	2	Wheel motor encoder failure. Please contact Shark Customer Service at 1-888-228-5531.

For all other issues, please call Customer Service at 1-888-228-5531.

What should I do if my robot won't connect to Wi-Fi, or loses connection with Wi-Fi or the app?

Your robot may temporarily lose connectivity when it goes under furniture, moves far from your router, or enters a zone that blocks Wi-Fi. Your robot should automatically reconnect to Wi-Fi on its own. If your robot loses connectivity and does not reconnect:

- Make sure your phone is connected to your home Wi-Fi network before trying to connect your robot.
- Typical home Wi-Fi networks support both 2.4 GHz and 5 GHz. Make sure you are connected to a 2.4 GHz network when you enter your username and password.
- Make sure the robot's power switch is turned to the (I) ON position. There should be an audio prompt when the robot's power is turned on.
- Do not use a VPN or a proxy server. Make sure Wi-Fi isolation is turned off on the router.

To reconnect your robot:

- Press and hold both the Dock and Clean buttons simultaneously until you hear the audio prompt and the Wi-Fi light on the robot blinks.
- If you are using an iOS phone, exit the app at this point. Open Wi-Fi settings and select your robot from the menu. Exit settings and return to the SharkClean app.
- Select your 2.4 GHz Wi-Fi network to connect your robot.

If the robot still won't connect:

1. Press the switch on the side of the robot to the (O) position to turn off the power. Wait 10 seconds, then turn the power back on and wait for the audio prompt.
2. Power off your phone. Wait 30 seconds, then power your phone back on.
3. Open Wi-Fi settings on your phone. Find the Shark network, then select Forget Network.
4. Reopen the SharkClean app and try the connection process again. For more help, please contact robot support at 1-888-228-5531.

How do I select specific rooms to clean?

Use the SharkClean® app. From the home screen of the app, select Clean. If your map is complete and you have defined and named the rooms on the map, a list of the rooms will appear. You can choose up to 3 rooms from the list to clean immediately. Select Start Cleaning to begin.

Or you can use voice commands through Amazon Alexa or Google Home to clean one room at a time:

- "Alexa, tell Shark to clean the (name of the room)."
- "Okay Google, tell Shark to clean the (name of the room)."

For more help, contact robot support at 1-888-228-5531.

Why isn't my robot charging?

- Verify that the base is connected to power and the power switch on the back of the base is in the (I) ON position. When the base is plugged in and the power switch is turned on, the GREEN power indicator light  on the base will illuminate. If the green light is not on, try connecting to a different electrical outlet.
- If the BLUE charging indicator light on the base is not on, verify that the power switch on the side of the robot is set to the (I) ON position. If the robot still is not charging, verify that the power switch on the back of the base is set to the (I) ON position.
- The robot must be aligned correctly on the base, with its back side against the debris intake on the base. The two metal pads on the bottom of the robot must be touching the metal charging contacts on the base.

When charging begins, the robot will beep. The BLUE charging indicator light on the base will PULSE, and the battery light on the robot will flash blue.

When charging is complete, the battery light on the robot and the blue charging indicator light on the base will both illuminate steadily.

NOTE: Charge the battery completely before first use. A full charge may take up to 6 hours. When charging is complete, the battery indicator light on the robot and the blue charging indicator light on the base will illuminate steadily. For more help, contact robot support at 1-888-228-5531.

How long will it take my robot to generate an interactive map?

It may take several cleanings for the robot to finish building the interactive map in the app. Make sure your robot is fully charged before sending it out to clean. It may take 4-6 hours to reach a full charge. If the robot has a problem when mapping, resolve the issue and restart the robot from the same spot. Make sure to open interior doors in rooms to be cleaned and that the robot is operating in well-lit areas. If the robot is running at night, make sure to turn on the lights in all rooms to be cleaned.

NOTE: Avoid picking up or moving the robot or the base. If either are relocated, the robot may not be able to generate a map or find its way back to the base. For more help, please contact robot support at 1-888-228-5531.

IMPORTANT: PLEASE READ THE TERMS AND CONDITIONS OF THIS LICENSE AGREEMENT CAREFULLY BEFORE CONTINUING WITH THIS PROGRAM INSTALL OR USE OF THIS PRODUCT: SharkNinja Operating LLC's ("SharkNinja") End-User License Agreement ("EULA") is a legal agreement between You (either a single entity or an individual) and SharkNinja for SharkNinja's Software Applications, including those installed by You onto your SharkNinja products or already installed on your device, including all firmware (referred hereafter as "SN APPS"). By installing, copying, checking a box, clicking a button confirming your agreement to these terms, or otherwise continuing to use the SN APPS, You agree to be bound by the terms of this EULA. This license agreement represents the entire agreement concerning SN APPS between You and SharkNinja, and it supersedes any prior proposal, representation, or understanding between the parties. If You do not agree to the terms of this EULA, do not install or use the SN APPS or this product. The SN APPS are protected by copyright laws and international copyright treaties, as well as other intellectual property laws and treaties.

1. GRANT OF LICENSE. The SN APPS are licensed as follows:

1.1 Installation and Use. SharkNinja grants You the right to download, install, and use SN APPS on the specified platform for which the SN APP was designed and in connection with SharkNinja products with which the SN APPS are designed to operate ("SN Devices").

1.2 Backup Copies. You may also make a copy of SN APPS downloaded and installed by You for backup and archival purposes.

2. DESCRIPTION OF OTHER RIGHTS AND LIMITATIONS.

2.1 Maintenance of Copyright Notices. You must not remove or alter any copyright notices on any and all copies of the SN APPS.

2.2 Distribution. You may not distribute copies of the SN APPS to third parties.

2.3 Prohibition on Reverse Engineering, Decompilation, and Disassembly. You may not reverse engineer, decompile, or disassemble SN APPS, except and only to the extent that such activity is expressly permitted by applicable law notwithstanding this limitation.

2.4 Rental. You may not rent, lease, or lend SN APPS without written permission from SharkNinja.

2.5 NOT FOR RESALE SOFTWARE. Applications identified as "Not for Resale" or "NFR," may not be resold, transferred, or used for any purpose other than demonstration, test, or evaluation.

2.6 Support Services. SharkNinja may provide You with support services related to SN APPS ("Support Services"). Any supplemental software code provided to You as part of the Support Services shall be considered part of SN APPS and subject to the terms and conditions of this EULA.

2.7 Compliance with Applicable Laws. You must comply with all applicable laws regarding use of SN APPS.

3. UPDATES. SharkNinja may provide You with upgrades or updates to SN APPS. This EULA will govern any upgrades provided by SharkNinja that replace and/or supplement SN APPS, unless such upgrade is accompanied by a separate EULA, in which case the terms of that EULA will govern. If You decide not to download and use an upgrade or update provided by SharkNinja, You understand that You could put SN Apps at risk to serious security threats or cause SN Apps to become unusable or unstable.

4. DATA AND PRIVACY. SharkNinja is committed to ensuring your privacy by adhering to high standards of fairness and integrity. We are committed to keeping our customers informed about how we use the information we gather from You through the use of each of our websites or SN APPS. Our privacy practices are described in SharkNinja's Privacy Policy, as well as in separate notices given when an app, product, or service is purchased or downloaded. By using SN APPS or providing us with your personal information, You are accepting and consenting to the practices, terms, and conditions described in SharkNinja's Privacy Policy. At all times your information will be treated in accordance with the SharkNinja Privacy Policy, which is incorporated by reference into this EULA and can be viewed at the following URL:

<http://www.sharkninja.com/privacypolicy>.

5. THIRD-PARTY APPLICATION LIBRARIES AND EMBEDDED SOFTWARE.

5.1 You acknowledge that Ayla Networks, Inc. ("Ayla") has provided certain application libraries that have been embedded into SN APPS ("Ayla Application Libraries") and enables SN Devices to connect to the Ayla Cloud Service ("Ayla Embedded Software").

5.2 You will not use the Ayla Application Libraries except as an incorporated portion of SN APPS, unmodified from the form provided to You.

5.3 You will not use the Ayla Embedded Software except as an incorporated portion of SN Devices, unmodified from the form provided to You.

5.4 You will not modify, adapt, translate, or create derivative works based on, or decompile, disassemble, reverse engineer, or otherwise attempt to derive the source code or underlying algorithms of, the Ayla Application Libraries or the Ayla Embedded Software.

5.5 SharkNinja retains all ownership of SN APPS (and the Ayla Application Libraries contained therein) and any software installed on SN Devices (including the Ayla Embedded Software) and only a license thereto is granted to You for use in connection with the SN APPS and SN Devices.

5.6 You will not use the Ayla Application Libraries or Ayla Embedded Software to attempt to gain unauthorized access to or use of the systems/services of SharkNinja's other licensors; nor will You transmit viruses, worms, Trojan horses, time bombs, spyware, malware, cancelbots, passive collection mechanisms, robots, data mining software, or any other malicious or invasive code or program into the systems/services of SharkNinja's other licensors.

5.7 You will not use the Ayla Application Libraries or Ayla Embedded Software to interfere with, breach, or circumvent any security feature, authentication feature, or any other feature that restricts or enforces limitations on the use of, or access to, the systems/services of SharkNinja's other licensors.

5.8 You will not probe, attack, scan, or test the vulnerability of the systems/services of SharkNinja's other licensors.

5.9 SharkNinja's other licensors of the SN APPS, Ayla Application Libraries, and the Ayla Embedded Software are the express third-party beneficiaries of this EULA, and the provisions of this Section of this EULA are made expressly for the benefit of such licensors, and are enforceable by such licensors.

6. TERMINATION. Without prejudice to any other rights, SharkNinja may terminate this EULA if You fail to comply with the terms and conditions of this EULA. In such event, You must destroy all copies of SN APPS in your possession.

7. COPYRIGHT. All title, including but not limited to copyrights, in and to SN APPS and any copies thereof are owned by SharkNinja or its suppliers. All title and intellectual property rights in and to the content which may be accessed through use of SN APPS are the property of the respective content owner and may be protected by applicable copyright or other intellectual property laws and treaties. This EULA grants You no rights to use such content. All rights not expressly granted are reserved by SharkNinja.

8. OPEN SOURCE SOFTWARE. You hereby acknowledge that SN APPS may contain software that is subject to "open source" or "free software" licenses ("Open Source Software"). The license granted by this EULA does not apply to Open Source Software contained in the SN APPS. Rather, the terms and conditions in the applicable Open Source Software license shall apply to the Open Source Software. Nothing in this EULA limits your rights under, or grants You rights that supersede, any Open Source Software license. You acknowledge that the Open Source Software license is solely between You and the applicable licensor of the Open Source Software. To the extent the terms of the licenses applicable to the Open Source Software require SharkNinja to provide the Open Source Software, in either source or executable form, or to provide copies of applicable license terms or other required information, You may obtain a copy of the software by contacting SharkNinja at the below physical address. Additional information about the Open Source Software, and its terms of use, may be found at www.sharkclean.com/opensource.

9. NO WARRANTIES. SharkNinja expressly disclaims any warranty for SN APPS, Ayla Application Libraries, or Ayla Embedded Software. SN APPS, Ayla Application Libraries, and Ayla Embedded Software are provided 'As Is' without any express or implied warranty of any kind, including but not limited to any warranties of merchantability, noninfringement, fitness of a particular purpose, or title. SharkNinja does not warrant or assume responsibility for the accuracy or completeness of any information, text, graphics, links, or other items contained within the SN APPS. SharkNinja makes no warranties respecting any harm that may be caused by the transmission of a computer virus, worm, logic bomb, or other such computer program. SharkNinja further expressly disclaims any warranty or representation to any third party.

10. LIMITATION OF LIABILITY. In no event shall SharkNinja or its suppliers be liable for any special, incidental, punitive, indirect, or consequential damages whatsoever (including, but not limited to, damages for loss of profits or confidential or other information, for business interruption, for personal injury, for loss of privacy, for failure to meet any duty including of good faith or of reasonable care, for negligence, and for any other pecuniary or other loss whatsoever) arising out of or in any way related to the use of or inability to use SN Devices or SN APPS, the provision of or failure to provide support or other services, information, software, and related content through the product or otherwise arising out of the use of SN APPS, or otherwise under or in connection with any provision of this EULA, even in the event of the fault, tort (including negligence), strict liability, breach of contract, or breach of warranty of SharkNinja or any supplier, and even if SharkNinja or any supplier has been advised of the possibility of such damages. SharkNinja shall have no liability with respect to the content of the SN APPS or any part thereof, including but not limited to errors or omissions contained therein, libel, infringements of rights of publicity, privacy, trademark rights, business interruption, personal injury, loss of privacy, moral rights, or the disclosure of confidential information.

11. APPLICABLE LAW. The laws of the Commonwealth of Massachusetts will govern this EULA and You hereby consent to exclusive jurisdiction and venue in the state and federal courts sitting in the Commonwealth of Massachusetts.

12. ASSIGNMENT. SharkNinja may assign this EULA without notice to Licensor.

13. ENTIRE AGREEMENT. This EULA (including any addendum or amendment to this EULA which is included with the SN Devices) is the entire agreement between You and SharkNinja relating to the SN APPS and supersedes all prior or contemporaneous oral or written communications, proposals and representations with respect to the SN APPS or any other subject matter covered by this EULA. To the extent the terms of any SharkNinja policies or programs for support services conflict with the terms of this EULA, the terms of this EULA shall control.

If You have questions regarding this EULA, please contact SharkNinja at 89 A Street, Suite 100, Needham, MA 02494.

ONE (1) YEAR LIMITED WARRANTY

The One (1) Year Limited Warranty applies to purchases made from authorized retailers of **SharkNinja Operating LLC**. Warranty coverage applies to the original owner and to the original product only and is not transferable.

SharkNinja warrants that the unit shall be free from defects in material and workmanship for a period of one (1) year from the date of purchase when it is used under normal household conditions and maintained according to the requirements outlined in the Owner's Guide, subject to the following conditions and exclusions:

What is covered by this warranty?

1. The original unit and/or non-wearable components deemed defective, in SharkNinja's sole discretion, will be repaired or replaced up to one (1) year from the original purchase date.
2. In the event a replacement unit is issued, the warranty coverage ends six (6) months following the receipt date of the replacement unit or the remainder of the existing warranty, whichever is later. SharkNinja reserves the right to replace the unit with one of equal or greater value.

What is not covered by this warranty?

1. Normal wear and tear of wearable parts (such as foam filters, filters, batteries, brushrolls, etc.), which require regular maintenance and/or replacement to ensure the proper functioning of your unit, are not covered by this warranty. Replacement parts are available for purchase at sharkaccessories.com.
2. Any unit that has been tampered with or used for commercial purposes.
3. Damage caused by misuse (e.g., vacuuming up water or other liquids), abuse, negligent handling, failure to perform required maintenance (e.g., not cleaning the filters), or damage due to mishandling in transit.
4. Consequential and incidental damages.
5. Defects caused by repair persons not authorized by SharkNinja. These defects include damages caused in the process of shipping, altering, or repairing the SharkNinja product (or any of its parts) when the repair is performed by a repair person not authorized by SharkNinja.
6. Products purchased, used, or operated outside North America.

How to get service

If your appliance fails to operate properly while in use under normal household conditions within the warranty period, visit sharkclean.com/support for product care and maintenance self-help. Our Customer Service Specialists are also available at **1-888-228-5531** to assist with product support and warranty service options, including the possibility of upgrading to our VIP warranty service options for select product categories. Please register your product and have it with you when contacting Customer Service.

SharkNinja will cover the cost for the customer to send in the unit to us for repair or replacement. A fee of \$25.95 (subject to change) will be charged when SharkNinja ships the repaired or replacement unit.

How to initiate a warranty claim

You must call **1-888-228-5531** to initiate a warranty claim. You will need the receipt as proof of purchase. A Customer Service Specialist will provide you with return and packing instruction information.

How state law applies

This warranty gives you specific legal rights, and you also may have other rights that vary from state to state. Some states do not permit the exclusion or limitation of incidental or consequential damages, so the above may not apply to you.

REGISTER YOUR PURCHASE

 registryyourshark.com



RECORD THIS INFORMATION

Model Number: _____

Date of Purchase: _____
(Keep receipt)

Store of Purchase: _____

TIP: You can find the model and serial numbers on the QR code label on the bottom of the robot.

EXPECTED PERFORMANCE

Expected runtime: at least 60 minutes

Expected charging time: 6 hours

PLEASE READ CAREFULLY AND KEEP FOR FUTURE REFERENCE.

This Owner's Guide is designed to help you keep your Shark iQ Robot® running at peak performance.

SharkNinja Operating LLC
US: Needham, MA 02494
CAN: Ville St-Laurent, QC H4S 1A7

1-888-228-5531
sharkclean.com

Illustrations may differ from actual product. We are constantly striving to improve our products; therefore the specifications contained herein are subject to change without notice.

This product may be covered by one or more U.S. patents. See sharkninja.com/patents for more information.



FCC WARNINGS

This equipment has been tested and found to comply with the limits for a Class B digital device, pursuant to parts 15 of the FCC Rules. These limits are designed to provide reasonable protection against harmful interference in a residential installation. This equipment generates, uses, and can radiate radio frequency energy and, if not installed and accordance with the instructions, may cause harmful interference to radio communications. However, there is no guarantee that interference will not occur in a particular installation. If this equipment does cause harmful interference to radio or television reception, which can be determined by turning the equipment off and on, the user is encouraged to try to correct the interference by one or more of the following measures:

- Reorient or relocate the receiving antenna.
- Increase the separation between the equipment and receiver.
- Connect the equipment into an outlet on a circuit different from that to which the receiver is connected.
- Consult the dealer or an experienced radio/TV technician for help.

This Device complies with part 15 of the FCC rules. Operation is subject to the following conditions:

- 1 This device may not cause harmful interference
- 2 This device must accept any interference received, including interference that may cause undesired operation.

Changes or modifications not expressly approved by the party responsible for compliance could void the user's authority to operate this device.



BATTERY REMOVAL AND DISPOSAL

This product uses a battery. When the battery no longer holds a charge, it should be removed from the vacuum and recycled. **DO NOT** incinerate or compost the battery.

When your lithium-ion battery needs to be replaced, dispose of it or recycle it in accordance with local ordinances or regulations. In some areas, it is illegal to place spent lithium-ion batteries in the trash or in a municipal solid waste stream. Return spent battery to an authorized recycling center or to retailer for recycling. Contact your local recycling center for information on where to drop off the spent battery.

For more information on battery removal for disposal, please visit sharkclean.com/batterysupport.

The RBRC™ (Rechargeable Battery Recycling Corporation) seal on the lithium-ion battery indicates that the costs to recycle the battery at the end of its useful life have already been paid by SharkNinja. In some areas, it is illegal to place spent lithium-ion batteries in the trash or municipal solid waste stream and the RBRC program provides an environmentally conscious alternative.

RBRC, in cooperation with SharkNinja and other battery users, has established programs in the United States and Canada to facilitate the collection of spent lithium-ion batteries. Help protect our environment and conserve natural resources by returning the spent lithium-ion battery to an authorized SharkNinja service center or to your local retailer for recycling. You may also contact your local recycling center for information on where to drop off the spent battery, or call 1-800-798-7398.

© 2021 SharkNinja Operating LLC. BOTBOUNDARY, SHARK, SHARKCLEAN, SHARK IQ ROBOT, and SHARK IQ ROBOT SELF-EMPTY are registered trademarks of SharkNinja Operating LLC. RBRC is a trademark of Rechargeable Battery Recycling Corporation. APP STORE is a service mark of Apple Inc., registered in the U.S. and other countries. GOOGLE, GOOGLE ASSISTANT, GOOGLE PLAY, the Google Play logo, and Android are trademarks of GOOGLE LLC.

RV1000AESeries_IB_E_REV_Mv23
PRINTED IN CHINA



@sharkcleaning