

USER MANUAL

SONICBOOM® RGB

V1.0
2026/03/10



Thanks for choosing SHOWVEN® SONICBOOM® RGB, we wish it will bring you lots of exciting moments.
Please read the following manual carefully before operating this product.

▲ Safety Instructions

1. Safety icons explanation

Safety instructions warn of hazards when handling equipment and provide information on how to avoid those hazards. They are classified according to the severity of the hazard and are divided into the following groups. Please do follow all safety instructions in this document!

DANGER: Indicates a hazardous situation that, if not avoided, will result in death or serious injury. (This signal word is limited to the most extreme situations)

WARNING: Indicates a hazardous situation that, if not avoided, could result in serious injury.

CAUTION: Indicates a hazardous situation that, if not avoided, could result in minor or moderate injury.

NOTICE: Provide additional or supplementary information.

2. General Safety Instructions

- \\ Unauthorized repair are prohibited, it may cause serious incident.
- \\ Make sure power supply in consistent with the rated voltage of the equipment, and the socket must well grounded. Unplug and turn off the machine when not use.
- \\ For adult use only, keep it away from fire, inflammable and explosive articles.
- \\ Installed in well ventilated area, ensure at least 50cm space around the machine, cover of the nozzle is forbidden.
- \\ If the machine fails to work, please stop operation and unplug the machine. Check fog fluid, fuse, power connection etc. carefully, if can't solve the problem, please contact SHOWVEN® or your local SHOWVEN® partner for advice.
- \\ Suggest use SHOWVEN® original FX-S / RED, FX-S/GREEN, FX-S/BLUE, FX-S/YELLOW, FX-S/PURPLE) fog fluid, other fluid may lead to clog or malfunction. Please do not adding any other material such as pigment, water etc. to the fuel tank.
- \\ If need to install SONICBOOM® RGB in invert direction, please also change the fluid tank upside down.
- \\ In case of eye contact of fog fluid, please wash it with clean water. If fluid is swallowed immediately look for medical advice.

Δ Technical Specifications

- \ **DIMENSION:** 440×360×305mm
- \ **WEIGHT:** 31kg
- \ **VOLTAGE:** AC220-240V / AC100-120V,50/60Hz
- \ **POWER:** 2400W(standard power mode) /1800W(low power mode)
- \ **USAGE IN RAIN:** YES
- \ **MAX. OUTPUT DISTANCE:** 12m
- \ **MAX. CONTINUOUS OUTPUT DURATION:** 6s
- \ **HEATING UP TIME:** 17min (low power mode takes longer time)
- \ **OUTPUT:** 100000cuft/min
- \ **FLUID CONSUMPTION RATE:** 500ml/min
- \ **TANK CAPACITY:** 3L
- \ **DMX CHANNEL:** 1CH-N / 2 CH-P
- \ **DMX INTERFACE:** 3-PIN AND 5-PIN DMX
- \ **CONSUMABLES:** FX-S/PINK, FX-S/GREEN, FX-S/BLUE, FX-S/YELLOW, FX-S/PURPLE

NOTICE: There is no low power mode if under RGB smoke mode (Advanced Menu / Fog Select / RGB Smoke).

Δ Structure

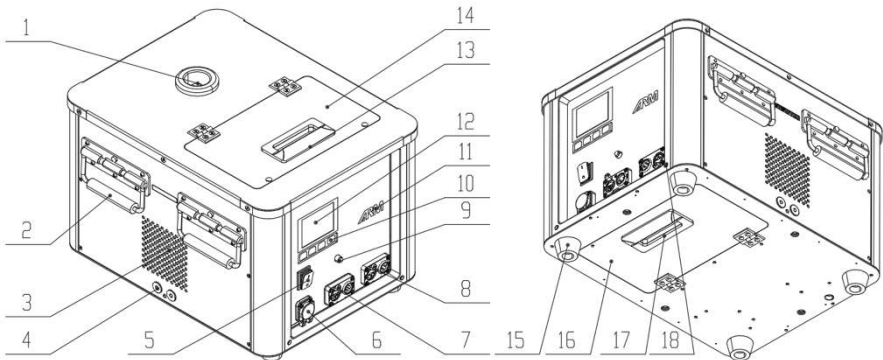

1. Output Nozzle
2. Handle
3. Air Inlet
4. Bracket Installation Hole
5. Power Switch
6. Power IN Socket

7. 5-PIN DMX
8. 3-PIN DMX
9. Fuse
10. LCD Screen Keypad Area
11. ARM Indicator Light
12. LCD Screen
13. Fluid Tank Top Panel Cover Handle
14. Fluid Tank Top Panel Cover
15. Feet
16. Fluid Tank Bottom Panel Cover Handle
17. Fluid Tank Bottom Panel Cover
18. Safety loop hole

Δ Operation Area

1. ARM alarming light



OFF: DMX IN signal.

BLINK: DMX armed, ready for firing

ON: No DMX signal.

NOTE: you can turn off the ARM light in ADVANCED menu by switch the ARM State to OFF status.

2. Display Interface

| | | | | |
|---|----------|-------|--------|------|
| ① | RGB 110V | | | |
| | DMX | SAFE | TEMP | PRES |
| ② | 001 | 002 | 100 | 135 |
| ③ | Ready | | | |
| ④ | MENU | TIMER | VOLUME | MONI |

2.1 Status Bar

RGB: Color smoke status

Normal: Normal status

NOTICE: 110V displays only when input 110V power.

2.2 Data Bar

DMX: DMX address, red background means DMX connected.

SAFE: Safety channel address, it appears when “Channel Mode” is “1CH-P”, when safety channel DMX value is between 50-200 the background color will turn into RED, otherwise it is BLACK.

TEMP: Temp. percentage of heating block, RED background means machine temp. reached 95% of set temp. and ready to shot, otherwise it is in WHITE background. BLACK background and display 995 means temp. sensor disconnect.

PRES: Device present pressure value. RED background means machine pressure ready to shot. Background turns to WHITE if current pressure lower than setting pressure

2.3 Message Bar

Shows device status, error information if any, or firing duration and intervals when firing manually.

2.4 Touch Keypad Bar

MENU / BACK: MENU or BACK

UP / LEFT / TIMER: Parameters up, items switch up or left, firing interval

DOWN / RIGHT / VOLUME: Parameters down, items switch down or right, manual firing

MONI / EDIT / SAVE: Data monitoring, edit or save

3. Error information

| Error information | Explanation |
|--------------------|--|
| E0 Factory Mode | Device under “Factory Mode”, please change to “User Mode” |
| E1 Pressure Err | Pressurize time exceed setting time, pressurize fail or no fog fluid. Fill tank and restart. |
| E2 Temp. Sensor | Temperature sensor fault (disconnect or damage) |
| E3 Ptemp Over | Machine chassis over temp. |
| E4 Pressure Sensor | Pressure sensor fault (disconnect or damage) |
| E5 KTemp Over | Heating block over temp. |
| E6 Heat Fail | Heating up time exceed setting time. Heating element damage or circuit fault or unstable voltage |
| E7 Pump Protect | Pump over current, restart machine |

4. Monitor interface:

From this interface, we can check the pressure, pump current, PCBA TEMP., heating block temp. of machine.

| MONITOR | | | |
|------------------|-------|--------|------|
| Pressure | 135 | | |
| Pump Current | 00.0A | | |
| PCBA Temperature | 8 | | |
| Temperature | 29 | | |
| BACK | TIMER | VOLUME | MONI |

5. Main Menu

Select "MAIN" in main interface, Press "EDIT" enter main menu.

| MAIN | |
|-----------------|----------------|
| Set DMX Address | 1 |
| Set Power | Standard Power |
| RDM | OFF |
| Channel Mode | 2CH-P |
| Set Safety Addr | 2 |
| BACK | UP |
| DOWN | EDIT |

| Options | Range | Default | Explanation |
|------------------|----------------------|----------------|--|
| Set DMX Address | 1~512 | 1 | Set DMX address |
| Set Power | Standard / Low Power | Standard Power | Setting working power for the machine. No low power mode under RGB SMOKE mode. |
| RDM | ON/OFF | OFF | RDM function setting |
| Channel Mode | 1CH-N/2CH-P | 1CH-N | Channel mode switch |
| Set Safety Addr. | 1-512 | 2 | Safety address setting |

6. Advanced Menu

Select "ADVANCED" in main interface, Press "EDIT" enter main menu.

| Options | Range | Default | Explanation |
|---------------|---------------------------------------|---------|--|
| Drive Test | Close/Relief/Priming/Pump /Reflux/Arm | OFF | Test the related hardware working status |
| Pressure Set | 120-150 | 135 | Setting target pressure |
| Interval Set | 1-200s | 30s | Interval time |
| Duration Set | 1-8s | 1s | Smoke output duration |
| Pump Timeout | 40-60s | 50s | Pump stop working after pressurize the setting time here. |
| Pump Protect | ON/OFF | ON | Pump protection set |
| ARM State | ON/OFF | ON | ARM light ON/OFF setting |
| 语言(Language) | 中文/English | English | Language switch |
| LCD Backlight | ON/OFF | ON | ON: LCD screen flash when firing OFF: LCD turn off after no operation during a period of time |
| Key Sound | ON/OFF | ON | Key pad sound ON/OFF switch |
| Key Lock | ON/OFF | OFF | Keypad lock if no operation in 30s, restart machine to enable |

| | | | |
|-------------------|--------------------------|-----------|--|
| Set Stop Time | 0.2s-2.0s | 0.8s | Set reflux valve working time |
| Fog Select | RGB Smoke / Normal Smoke | RGB SMOKE | Set this item according to the fog fluid used on machine |
| Default Parameter | ON/OFF | OFF | Parameters reset to default setting |

Δ DMX Control

There are two DMX channel mode for SONICBOOM® RGB, single channel mode and single channel with safety channel.

1CH-N: Single channel mode

Fog output and LED color controlled in the same channel.

| DMX value | Function |
|-----------|----------|
| 0-200 | FOG OFF |
| 201-255 | FOG ON |

1CH-N: Single channel mode

Fog output and LED color controlled in the same channel.

| Channel | DMX value and Function |
|-----------|--|
| Channel 1 | 0-200: FOG OFF 201-255: FOG ON |
| CH-S | Safety Channel: 50-200: pressurize and heating up; other value: heating off and firing disable. |

Δ Operation Guide

1. Safety Icon



This indicates a high-temperature area nearby; please be careful to avoid burns.

WARNING: *The output nozzle and surrounding area are high-temperature zones and should not be touched to avoid burns.*

2. Safety distance explanation

Safety distance for SONICBOOM RGB divided into two parts safety radius around machine (a) and safety distance at firing direction (b). No person and objects/materials that are easily stained are allowed to stay inside the safety isolation zone when SONICBOOM RGB was armed.

The safety isolation zone (show as below) is a cylindrical three-dimensional space with Safety radius around machine (a) and Height of b. Unauthorized persons and objects/materials that are easily stained are strictly prohibited from entering.

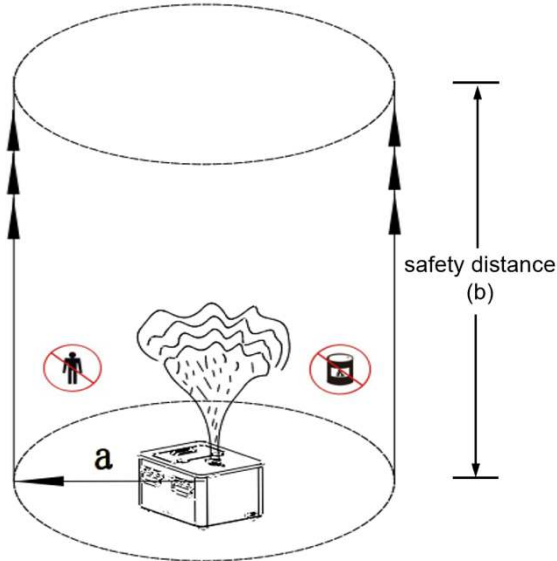

| Safety distance | Wind force level 0-1 | Wind force level 2-3 |
|-----------------|----------------------|----------------------|
| a | 4m | 8m |
| b | 20m | 20m |

NOTICE: The safety distance is primarily set to prevent colored smoke from staining other surfaces. If using SHOWVEN fog fluid FX-CI or if there are no easily stained objects nearby, the operator can adjust the safety distance appropriately based on their assessment of the surrounding environment and the safety of the device.

CAUTION: When the wind force exceeds level 3, the smoke effect of the equipment will be severely affected.

DANGER: Once the equipment is turned on, the nozzle should not be pointed at personnel or block the output nozzle.

3. Installation

SONICBOOM® RGB mostly suggest to use in outdoor and well-ventilated environment, it can be installed in any direction even upside down. But please watch out for the fog fluid leakage from the fluid tank.

For upside-down installation, please take out the fluid tank first, turn machine upside-down then place the fluid tank back again.

For safety, hanging installation should install safety rope.

The bracket and clamps are optional parts, if you need please contact SHOWVEN sales to order.

CAUTION:

Make sure the color smoke column not pointing to any objects or easily stainable surfaces, it may coloring the surface of objects.

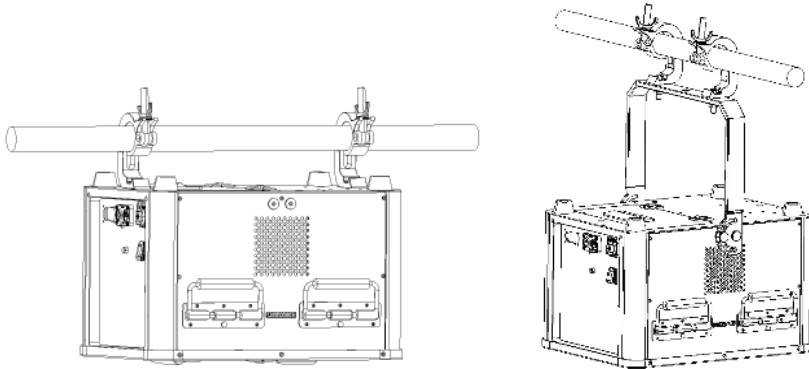

4. Fill the machine

Fill the fluid tank with SHOWVEN color smoke fluid.

Improper use of fluid will lead to machine malfunction. Warranty will be void if any other type of fog fluid is used.

NOTICE:

Always wearing gloves when filling fluid bottle and handling this equipment.

5. Power ON SONICBOOM® RGB

Connect the machine to suitable rated power supply. Make sure power supply in consistent with the rated voltage of the equipment, and the socket must well grounded.

Turn on the machine and allow it to heat up. It shows "Warm up" on LCD screen. It takes around 17min for the machine to finish heating up.

There are Standard power mode and Low power mode switchable, based on the power supply circumstance operator can switch the power mode in the menu. When in Low power mode the heating up time will be longer.

6. DMX setting

Set DMX address for each machine. Connect machines with DMX cable in series.

Suggest to plug in a DMX terminator into the DMX out in last unit of machine.

If operate manually, please disconnect DMX connection.

7. Firing

Once the machine has reached operating temperature, the LCD display of TEMP and PRES background color turns to red, and "TEMP" value reached 100, "PRES" value reached 135. Now the machine is ready for operation.

Manual operation: Press the "VOLUME" to start generating fog, press "STOP" to stop.

DMX control: please operate according to the DMX control table.

Double check the objects and person around machine, make sure the color smoke column not pointing to any person or objects.

8. Cleaning Process

After each show please remove color smoke fluid bottle and use FX-CI or distilled water to clean the pipe system by firing machine 5-10times. The cleaning process are as below:

- A. Depressurize the device. Power OFF the device, then turn it ON again, After hearing the start-up prompt sound, the device will immediately begin a depressurization operation. You will hear the pressure relief valve opening and the sound of pressure releasing from the pipeline. The total time is approximately 6 seconds. After the depressurization operation is complete, please turn off the power immediately to prevent the device from re-extracting colored smoke fluid and pressurizing it.
- B. Remove color smoke fluid bottle from machine, use FX-CI or distilled water (500ml minimum)
- C. Start the equipment and set the firing duration (no less than 6s), firing by controller or press "Volume" to firing if firing manually. Repeat this process 5-10 times. If the heater temperature is lower than the firing temperature, do not operate. Wait until the temperature rises back above 95% before continuing. The number of firing cycles depends on the color of the output smoke. When the smoke is white or colorless, the cleaning is considered complete.
- D. Depressurize the machine by following step A, power OFF SONICBOOM RGB.

WARNING: *Cleaning process is very important for the service life of machine, heating aluminium block will easily clogged if not cleaned after each show.*

9. Packing and storage of machine and color smoke fluid

Please empty the fluid tank and clean the machine.

Allow the machine to cool down before packing it.

The the remaining color smoke fluid, please reseal the fluid bottle with original cap and store it in a cool and dark place. Do not tilt or invert the fluid bottle to prevent leakage and evaporation.

Δ FAQ

| FAQ | Why it happens | How to solve it |
|---|---|---|
| Few smoke output | <ul style="list-style-type: none"> 1. Fog fluid is not enough 2. Pipe system is blocked | <ul style="list-style-type: none"> 1. Filling the fog fluid tank, if there is sediment, please shake it well 2. Clean or replace the filter in fluid tank first, if still not work, then need to check the pipe system. |
| Reached setting temp. but still no smoke output | Heating block clogged | <ul style="list-style-type: none"> 1. Replace the color fog fluid with FX-CI, firing machine several times after heating up 2. Replace the heating block |
| Temp. can't reach setting temp. | Heating block's thermal protector was activated and disconnected | <ul style="list-style-type: none"> 1. Please check whether cooling fan is working normally 2. Power OFF machine and let machine cool down, then restart machine. |
| Machine can't be controlled by controller | Signal disconnected | <ul style="list-style-type: none"> 1. Check DMX connector on machine 2. Check DMX cable |

Δ Maintenance

1. Use SHOWVEN® original color smoke fluid FX-S/PINK, FX-S/GREEN, FX-S/BLUE, FX-S/YELLOW, FX-S/PURPLE or FX-CI.
2. Running the machine at least once per month.
3. Flushing SONICBOOM RGB by flowing the cleaning process as described above.
4. Whenever storage or not use the machine for a period of time, please use distilled water to wash the pipe system by filling the fluid bottle with distilled water and firing the machine several times.

Δ Optional Parts for SONICBOOM RGB

| Part. No. | Description | Pcs/machine |
|-----------|--|-------------|
| RMBOT036 | Safety loop | 2 |
| RMSTE1957 | Bracket (optional parts) | 1 |
| RMBOT312 | hand-tightening screws and bolts M6*20 | 4 |
| RMWAS104 | Gasket 16*16*2mm | 2 |
| RMSTE1953 | Clamps | 2 |

Δ **Warranty Instructions**

- \ Sincere thanks for your choosing our products, you will receive quality service from us.
- \ The product warranty period is one year. If there are any quality problems within 7 days after shipping out from our factory, we can exchange a brand new same model machine for you.
- \ We will offer free of charge maintenance service for machines which with hardware malfunction (except for the instrument damage caused by human factors) in warranty period. Please don't repair machine without factory permission.

Below situations NOT included in warranty service:

- \ Damage caused by use other type of fog fluid which is not SHOWVEN® original color smoke fluid.
- \ Damage caused by improper transportation, usage, management, and maintenance, or damage caused by human factors;
- \ Disassemble, modify or repair products without permission;
- \ Damage caused by external reasons (lightning strike, power supply etc.)
- \ Damage caused by improper installation or use;
- \ For product damage not included in warranty range, we can provide paid service.
- \ Invoice is necessary when applying for maintenance service from SHOWVEN®.

SHOWVEN[®]



Showven Technologies Co., Ltd.

Tel: +86-731-83833068

Web: www.showven.cn E-mail: info@showven.cn

Add: No.1 Tengda Road, Liuyang Economic & Technical Development Zone, Changsha, Hunan,
410300, P.R.China