

## Outside Air Sensor, 100K Ohm Thermistor

### Product Description

The Outside Air Sensor provides an input for temperature control to a controller.

### Product Number

536-778      0°F to 120°F (–18°C to 49°C) range

### Required Tools

- Power screwdriver with standard screw chuck or medium flat-blade screwdriver
- Wire cutter/stripper
- Drill and drill bits

### Expected Installation Time

Two hours

### Prerequisites

- Review these instructions before beginning.
- The appropriate field wiring within the maximum wiring run length for the individual field panel or equipment controller should be pulled through the conduit to a utility box near the sensor location.
- Verify the distance between the utility mounting box and the outlet end of the pulling elbow. If the distance is less than 22 inches (56 cm), follow *Option A*. If the distance is greater than 22 inches (56 cm), follow *Option B*.
- The preferred sensor location is the north side of the building, in the shade. The sensor must be protected from direct or indirect sunlight and drafts from exhaust outlets, etc.

### Installation

**NOTE:** All wiring must comply with National Electrical Code (NEC) and local regulations.

### Option A Installation

**NOTE:** If replacing an existing sensor, disconnect the positive signal (+) lead of the field wiring from the controller termination board or block.

1. Use an existing opening or drill an opening through the outside wall for 1/2-inch (13 mm) rigid conduit. The sensor must be located three to six inches (7.5 to 15 cm) from the wall.

Feed the sensor leads through the rigid conduit to the utility box located on the inside of the building. Thread the sensor onto the rigid conduit as shown in Figure 1.

2. Rotate the sensor so that the shield points down and shades the sensing element from direct and indirect sunlight.
3. Connect the sensor leads to the field wiring inside the utility box. See Figure 1.
4. Connect the field wiring to the controller as shown in the wiring diagram. See Figure 3.

The installation is now complete.

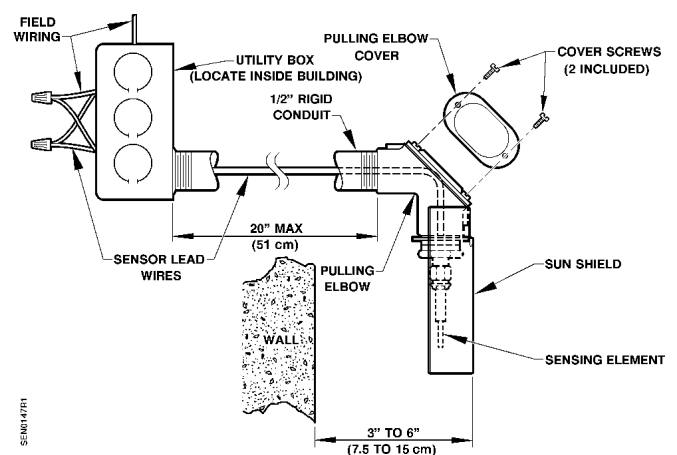

Figure 1. Outside Air Sensor, Option A Installation.

## Option B Installation

**NOTE:** If replacing an existing sensor, disconnect the positive signal (+) lead of the field wiring from the controller termination board or block.

1. Use an existing opening or drill an opening through the outside wall for 1/2-inch (13 mm) rigid conduit. The sensor must be located three to six inches (7.5 to 15 cm) from the wall.
2. Remove the pulling elbow cover and gasket.
3. Pull the sensor lead wires from the pulling elbow and thread the pulling elbow/sensor assembly onto the conduit as shown in Figure 2.
4. Rotate the sensor so that the shield points down and shades the sensing element from direct and indirect sunlight.
5. Cut off the excess sensor wire leads approximately one inch (25 mm) from the pulling elbow and strip 3/8-inch (9.5 mm) of insulation from the ends of the leads.
6. Pull the field wiring to the pulling elbow.
7. Connect the field wiring to the sensor wiring as shown in Figure 2.
8. Replace the pulling elbow cover and gasket. Ensure that the gasket seals the pulling elbow.
9. Connect the field wiring at the controller as shown in the wiring diagram. See Figure 3.

The installation is now complete.

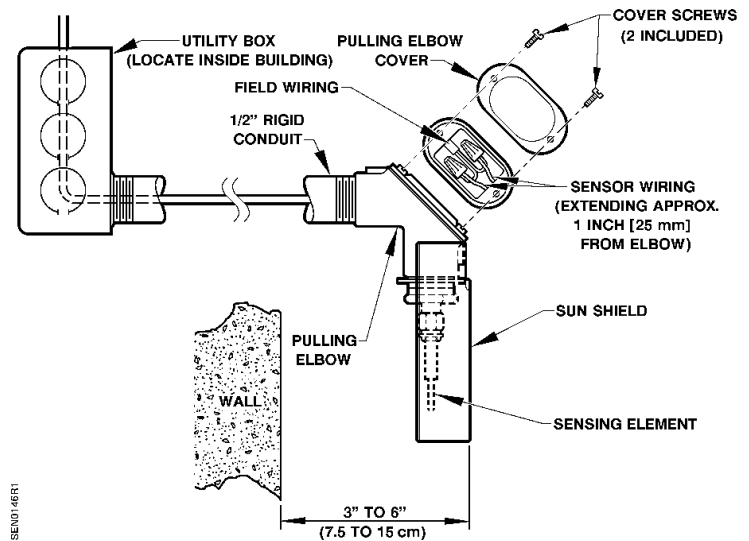

Figure 2. Outside Air Sensor, Option B Installation.

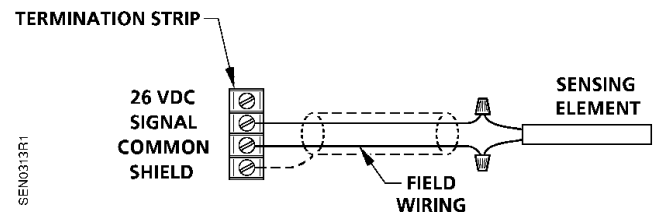

Figure 3. Wiring Diagram.

- NOTE:**
1. Some Siemens Building Technologies controllers may require a shield termination.
  2. For individual panel wiring details, refer to the appropriate hardware manual.