



Model: 1001D-A

INSTALLATION AND OPERATION INSTRUCTIONS

**IF YOU CANNOT READ OR UNDERSTAND THESE INSTALLATION INSTRUCTIONS
DO NOT ATTEMPT TO INSTALL OR OPERATE**

CALIFORNIA PROPOSITION 65



WARNING

This product can expose you to Tetrabromobisphenol-A, which is known to the state of California to cause cancer. (For more information, go to www.p65warnings.ca.gov)

INTRODUCTION

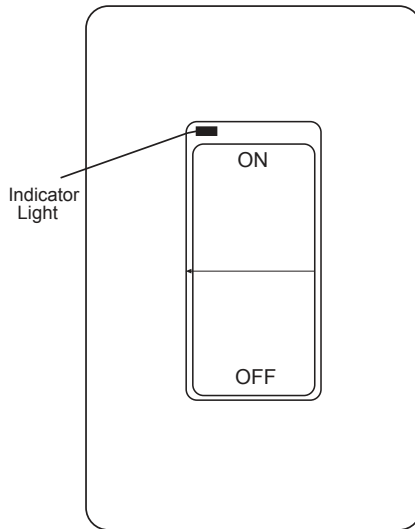

This remote control system was developed to provide safe, reliable, user-friendly remote control system for gas heating appliances. The system can be operated manually from the transmitter. It is a dry contact switch designed to be used with millivolt gas valves.

The wall transmitter operates on a (2) 3-volt button cell batteries (included). Before using the wall transmitter, install the (2) 3-volt button cell batteries. Follow instructions below.

The wall transmitter is an ON/OFF rocker switch. When the rocker switch on the wall transmitter is pressed, a indicator light on the wall transmitter illuminates briefly to verify that a signal has been sent. If the indicator light does not illuminate it could be the batteries. Be sure the batteries are installed with the (+) and (-) ends facing the correct direction, and are fully charged.

INSTALLING AND REPLACING BATTERIES

- Remove the faceplate from the base by inserting a small screwdriver into the small slot on the side of the faceplate (either side) then popping it off.
- To take the batteries out, insert a small screwdriver into slot at the button cell battery (shown on right) and pop batteries out.
- Place the button cell batteries into the battery holders, inserting the top edge under the metal clips and snap into place. Ensure the batteries are installed with (+) plus side facing up.
- After the batteries are installed replace the faceplate on the base.

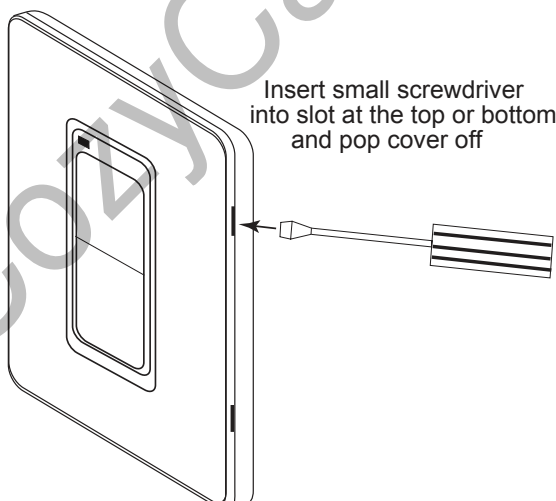

Insert small screwdriver into slot at the top or bottom and pop cover off

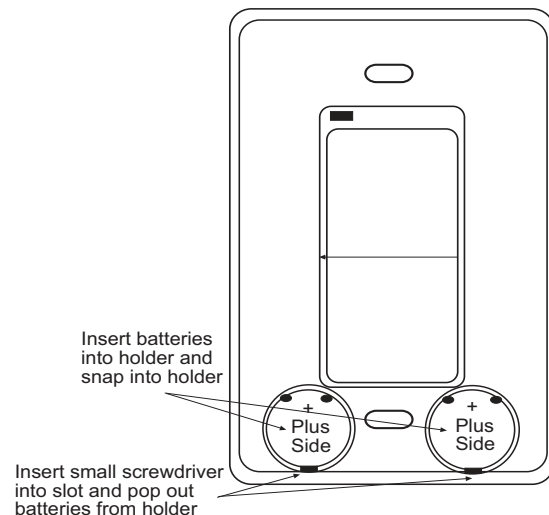

Insert batteries into holder and snap into holder

Insert small screwdriver into slot and pop out batteries from holder

WALL MOUNTING THE TRANSMITTER

- Remove faceplate from the base by inserting a small screwdriver into the small slot at the top or bottom of the faceplate then popping it off.
- Locate the (2) two mounting holes and mark the holes on the wall.
- Use the (2) two dry wall anchors and screws (supplied) to mount the base plate to the wall as shown.
- Then snap the faceplate back on to the wall-mounted transmitter.
- The wall transmitter can also be mounted onto an existing (not metal) electrical box.

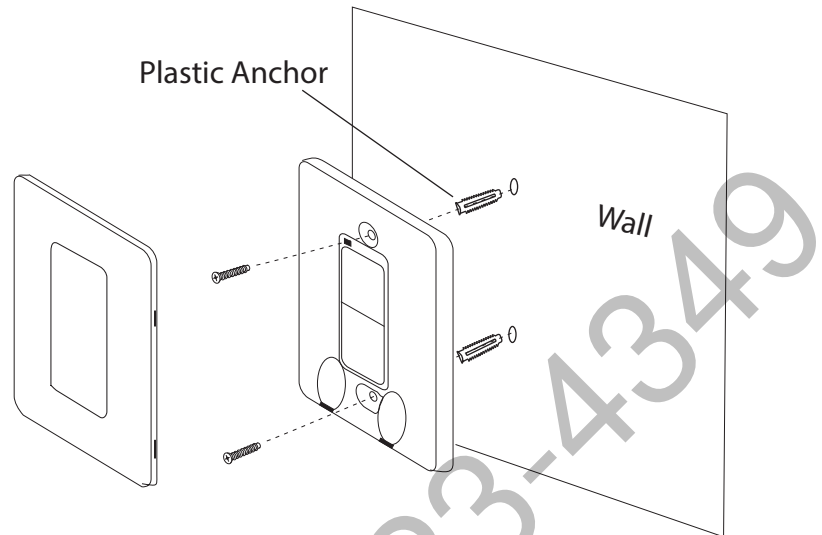

RECEIVER

Install the (4) AA-size batteries supplied with the unit. It is recommended that ALKALINE batteries always be used for this product. Be sure the batteries are installed with the (+) and (-) ends facing the correct direction.

The remote receiver has a 3-position slide switch for selecting the mode of operation ON/REMOTE/OFF

- ON: will manually turn ON the appliance.
- REMOTE: will allow use of handheld transmitter. If the system does not respond to the transmitter on initial use, check the battery positions in the remote. If that does not work, see the LEARNING TRANSMITTER TO RECEIVER section.
- OFF: will disable the remote receiver.

It is recommended that the slide switch be placed in the OFF position if you will be away from your home for an extended period of time.

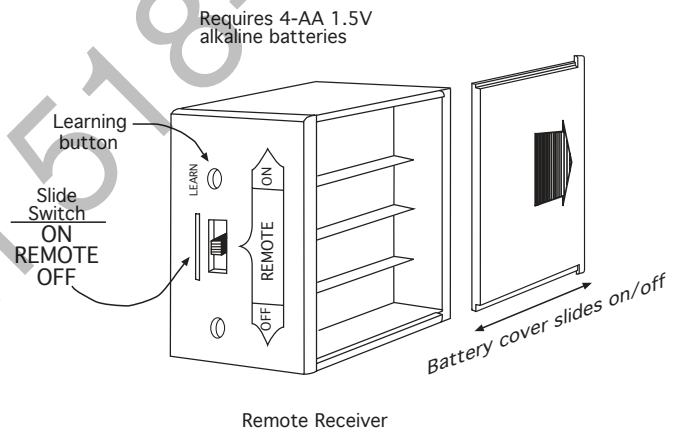

NOTE: This product is designed for use with an attended hearth appliance or fire feature. Adults must be present when the Control System is operating. DO NOT program or thermostatically set this Control to operate a hearth appliance or fire feature when Adults are not physically present. Furthermore, DO NOT leave the hearth appliance or fire feature burning unattended; it may cause damage or serious injury. If an Adult is going to be away from the hearth appliance or fire feature for any length of time, then the handheld/wall mount, receiver/control module and application should be in the "OFF" position.

WARNING

This remote control system must be installed exactly as outlined in these instructions. Read all instructions completely before attempting installation. Follow instructions carefully during installation. Any modifications of this remote control or any of its components will void the warranty and may pose a fire hazard.

Do not connect any gas valve or electronic module directly to 110-120VAC power. Consult gas appliance manufacturer's instructions and wiring schematics for proper placement of all wires. All electronic modules are to be wired to manufacturer's specifications.

The following wiring diagrams are for illustration purpose only. Follow instructions from manufacturer of gas valve and/or electronic module for correct wiring procedures. Improper installation of electric components can cause damage to electronic module, gas valve and remote receiver.

INSTALLATION

The remote receiver can be either wall-mounted in a standard plastic switch box (not metal) or placed on or near the fireplace hearth. Preferably, the remote receiver should be wall-mounted in a plastic switch box, as this will protect its electronic components from the heat produced by the gas appliance. The remote receiver should be kept away from temperatures exceeding 130° F. Battery life is also significantly shortened if batteries are exposed to temperatures 130°F or higher.

Before installation make sure the remote receiver slide switch is in the OFF position. After installation be sure that the slide switch is moved to the REMOTE position.

MOUNTING THE REMOTE RECEIVER

When wall mounting the remote receiver, longer wires (not included) are required to connect to the gas valve or electronic module. These wires must: Be at least 18 Gauge (AWG), no longer than 20-feet and have no splices.

WALL MOUNT

To attach Cover Plate to Receiver Box:

- Position the receiver as shown in diagram to the left with lower tab on cover plate inserted into groove of receiver (Make sure LEARN hole on cover plate properly aligns with remote receiver). Pull receiver up and snap into top tab of cover plate.
- Position the cover plate so the word ON is facing up; then, install the remote receiver into the plastic switch-box using the two long screws provided. Push the white button over the receiver slide switch.

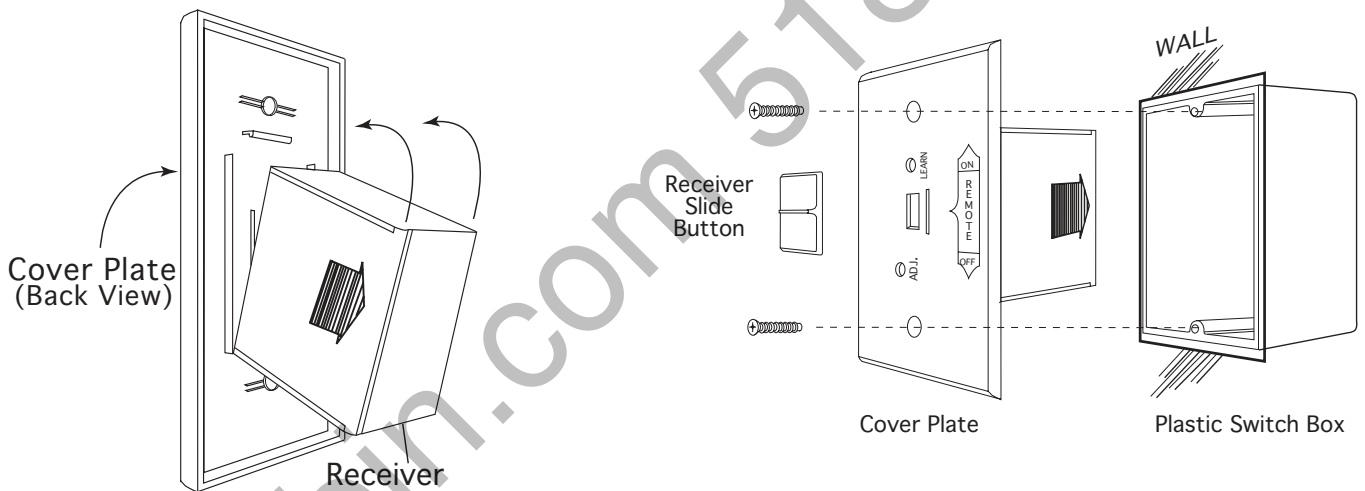

HEARTH MOUNT

The remote receiver can be placed on the fireplace hearth or under the fireplace behind the control access panel. Use the wires attached to the remote receiver to connect to the gas valve or the electric module (piggyback connectors have both male and female terminals for flexibility). Be sure that the connectors do not touch each other or other bare metal surfaces; this will cause the appliance to turn ON. The connectors may be wrapped with electrical tape to prevent this.

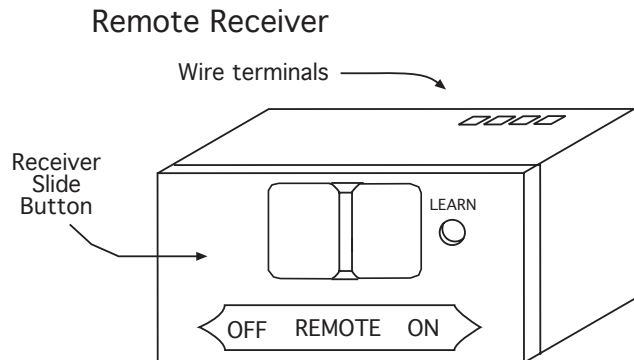

WIRING INSTRUCTIONS

Note: A qualified electrician should install the remote control system.

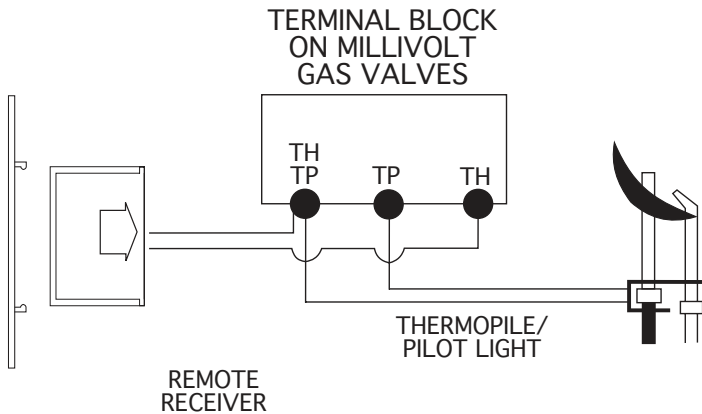

WIRING MILLIVOLT GAS VALVES

- Connect one wire from the remote receiver to the TH terminal on the gas valve.
- Connect the other wire from the remote receiver to the TH/TP terminal on the gas valve.

MILLIVOLT SYSTEM CHECK

- Ensure that the pilot flame is lit.
- Slide the 3-position button on the remote receiver to the ON position. The main gas flame (i.e., the fire) should ignite.
- Slide the button to OFF. The main flame should extinguish (the pilot flame will remain ON).
- Slide the button to REMOTE, and then press the ON button on the transmitter to change the system to ON. The main gas flame should ignite.

WIRING ELECTRONIC SPARK IGNITIONS SYSTEMS

The remote control receiver can be connected, in series, to a 24VAC transformer to the TR (transformer) terminal on the ELECTRONIC MODULE. Connect the hot wire from the 24VAC transformer to either of the wire terminals on the remote receiver. Connect another wire between the other receiver wire terminal and the TH (thermostat) terminal on the ELECTRONIC MODULE.

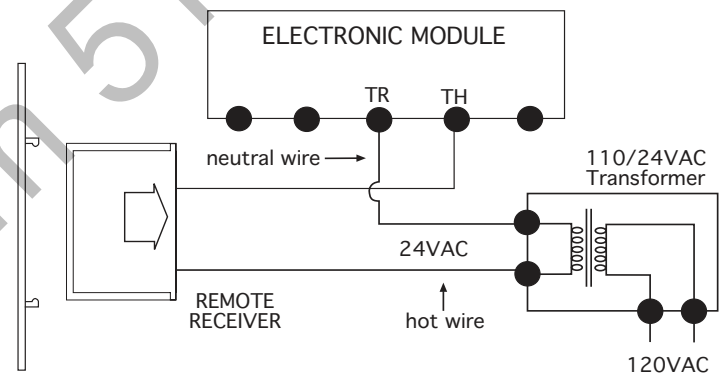

ELECTRONIC SPARK SYSTEM CHECK

- Slide the 3-position button on the remote receiver to the ON position. The spark electrode should begin sparking to ignite the pilot. After the pilot flame is lit, the main gas valve should open and the main gas flame should ignite.
- Slide the button to OFF. The main gas flame and pilot flame should both extinguish.
- Slide the button to REMOTE, and then press the ON button on the transmitter to change the system to ON. The spark electrode should begin sparking to ignite the pilot. After the pilot is lit, the main gas valve should open and the main gas flame should ignite.

GENERAL INFORMATION

LEARNING TRANSMITTER TO RECIEVER

Each transmitter uses a unique security code. It will be necessary to press the LEARN button on the receiver to accept the transmitter security code upon initial use, if batteries are replaced, or if a replacement transmitter is purchased from your dealer or the factory. In order for the receiver to accept the transmitter security code, be sure the slide button on the receiver is in the REMOTE position; the receiver will not LEARN if the slide switch is in the ON or OFF position. The LEARN button is located on the front face of the receiver; inside the small hole labeled LEARN. Using a small screwdriver or end of a paperclip gently press and release the black LEARN button inside the hole. When you release the LEARN button the receiver will emit an audible "beep". After the receiver emits the beep press the transmitter ON or OFF button for approximately 2 seconds and release. The receiver will emit several beeps indicating that the transmitter's code has been accepted into the receiver.

BATTERY LIFE

Life expectancy of the alkaline batteries in the transmitter and receiver should be at least 12 months. Check and replace all batteries:

1. Annually.
2. When operating range becomes reduced.
3. When transmissions are not received by the remote receiver.
4. If the remote receiver batteries measure less than 5.3 volts (all four batteries in combination).
5. If the transmitter batteries measure less than 2.4 volts (each battery).

TROUBLE SHOOTING

If you encounter problems with your fireplace system, the problem may be with either the fireplace itself or with the remote. Review the fireplace manufacturer's operation manual to make sure all connections are properly made. Then check the operation of the remote in the following manner:

- Make sure all batteries are correctly installed in the transmitter and receiver. Also check that the batteries are fully charged.
- Check batteries in transmitter to make sure contacts are touching (+) and (-) ends of battery. Bend metal contacts in for tighter fit.
- Be sure receiver and transmitter is within 20 to 25-foot operating range.
- Keep receiver from temperatures exceeding 130° F. Battery life will be shortened if exposed to high temperatures.
- If receiver is installed in a tightly enclosed metal surrounding, the operating distance will be shortened.
- Make sure the transmitter and remote receiver are communicating properly (see LEARNING TRANSMITTER TO RECEIVER section).

FCC REQUIREMENTS

NOTE: THE MANUFACTURER IS NOT RESPONSIBLE FOR ANY RADIO OR TV INTERFERENCE CAUSED BY UNAUTHORIZED MODIFICATIONS TO THE EQUIPMENT. SUCH MODIFICATIONS COULD VOID THE USER'S AUTHORITY TO OPERATE THE EQUIPMENT

FCC Notification

Note: This equipment has been tested and found to comply with limits for a Class B digital device, pursuant to part 15 of the FCC Rules. These limits are designed to provide reasonable protection against harmful interference in a residential installation. This equipment generates, uses and can radiate radio frequency energy and, if not installed and used in accordance with the instructions, may cause harmful interference to radio communications. However, there is no guarantee that interference will not occur in a particular installation. If this equipment does cause harmful interference to radio or television reception, which can be determined by turning the equipment off and on, the user is encouraged to try to correct the interference by one or more of the following measures:

- Reorient or relocate the receiving antenna
- Increase the separation between the equipment and the receiver
- Connect the equipment into an outlet on a circuit different from that to which the receiver is connected
- Consult the dealer or an experience radio/TV technician for help

**FOR TECHNICAL
SERVICE, CALL:**

U.S. INQUIRIES
(855) 498-8324 or (260) 459-1703

CANADIAN INQUIRIES
(877) 472-3923

Skytech Products Group
9230 Conservation Way
Fort Wayne, IN 46809
Sales Support: (888) 699-6167
Website: www.skytechpg.com

MANUFACTURED EXCLUSIVELY FOR SKYTECH II, INC

