



Model: 1001TH-A

INSTALLATION AND OPERATING INSTRUCTIONS

IF YOU CANNOT READ OR UNDERSTAND THESE INSTALLATION INSTRUCTIONS DO NOT ATTEMPT TO INSTALL OR OPERATE

INTRODUCTION

This remote control system was developed to provide a safe, reliable and user-friendly remote control system for gas heating appliances. It has a built-in thermostat. This all battery system operates independently of household current. The system operates on radio frequencies with a non-directional signals. The systems operating range is approximately 20-feet. The system operates on one of 1,048,576 security codes that are programmed into the transmitter at the factory; the remote receiver's code must be matched to that of the transmitter prior to initial use. It is designed to be used with millivolt gas valves as a dry contact switch.

Review COMMUNICATION SAFETY SECTION under TRANSMITTER section. These signal/temperature safety features shut down the fireplace system when a potentially unsafe condition exists.

TRANSMITTER

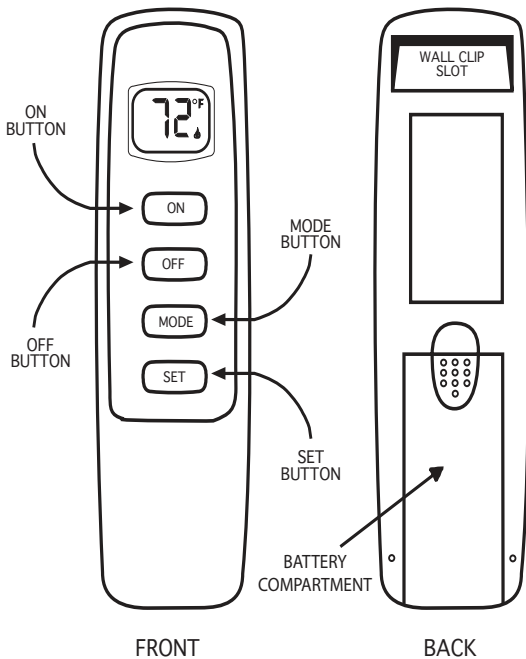

This remote control SYSTEM offers the user a battery-operated remote control that operates most millivolt gas valves used in some heater rated gas logs, gas fireplaces and other gas heating appliances.

The transmitter operates on (2) 1.5V AAA batteries.

It is recommended that ALKALINE batteries always be used for longer battery life and maximum operational performance.

Before using the transmitter, install the (2) AAA transmitter batteries into the battery compartment. (Use caution that batteries are installed in the proper direction)

BUTTON SETTINGS

1. **ON** --- Turns appliance ON
2. **OFF** -- Turns appliance OFF
3. **MODE** Cycles control between manual and thermo mode.
4. **SET** --- Sets temperature in thermo mode.

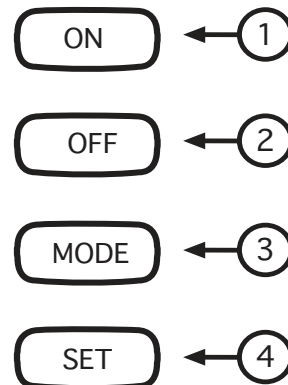

LCD - Liquid Crystal Display

Key

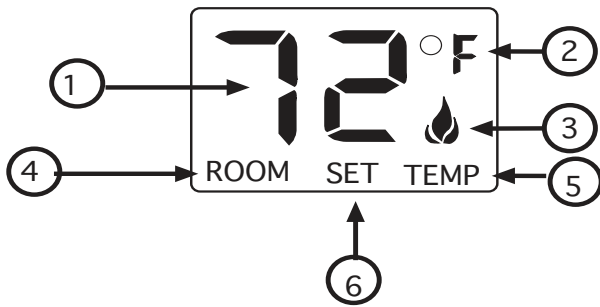

- | | |
|----------------------|--|
| 1. Display ----- | Indicates current room temperature |
| 2. F° or C° ----- | Indicates degrees Fahrenheit or Celsius |
| 3. Flame ----- | Indicates appliance is ON. |
| 4. Room ----- | Indicates remote is in THERMO mode. |
| 5. Temperature ----- | Appears during manual operation. |
| 6. Set ----- | Appears when setting the desired temperature in THERMO mode. |

SETTING °F / °C SCALE

The factory setting for temperature is °F. To change the displayed temperature, press the **ON** and **OFF** buttons at the same time. Follow this same procedure to return to °F.

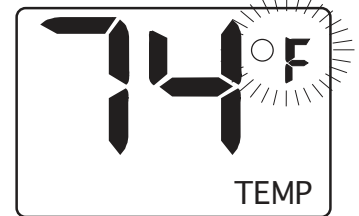

MANUAL FUNCTION

ON OPERATION

Press the **ON** button to turn the appliance **ON**. (The flame icon will appear on the LCD screen).



SCREEN WHILE DEPRESSING ON Button

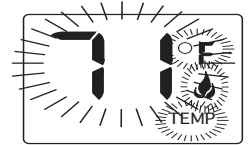

SCREEN AFTER 3 SECOND DEFAULT

OFF OPERATION

Press the **OFF** button to turn the appliance **OFF**. (The flame icon will disappear from the LCD screen.)

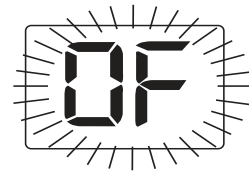

SCREEN WHILE DEPRESSING OFF Button



SCREEN AFTER 3 SECOND DEFAULT

THERMOSTAT FUNCTION

SETTING DESIRED ROOM TEMPERATURE

This remote control system can be thermostatically controlled when the transmitter is in the THERMO mode (The word **ROOM** must be displayed on the screen). To set the THERMO MODE and DESIRED room temperature, press the MODE button until the LCD screen shows the word ROOM, then the remote is in the thermostatic mode.



THERMO MODE

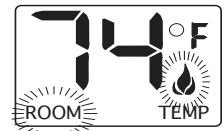

THERMO ON



THERMO SET

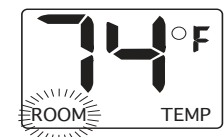

THERMO OFF

Press and hold the SET button until the desired set temperature is reached. (By pressing and holding the set button the LCD screen set numbers will increase from 45° to 99° then restart over at 45°. Release the SET button at desired temperature. The LCD screen will display the set temperature for 3 seconds and the LCD screen will flash the set temperature for 3 seconds, then the LCD screen will default to display the room temperature.

TO DISENGAGE THE THERMO MODE

Press the MODE button to disengage the thermo mode. The word ROOM will not show on the LCD screen when the thermo is not in operation.

NOTE: The highest SET temperature is 99° F (32° C) and the lowest temperature is 45° F (6° C).

OPERATIONAL NOTES

The Thermo Feature on the transmitter operates the appliance whenever the ROOM TEMPERATURE varies a certain number of degrees from the SET TEMPERATURE. This variation is called the “SWING” or TEMPERATURE DIFFERENTIAL. The normal operating cycle of an appliance may be 2-4 times per hour depending on how well the room or home is insulated from the cold or drafts. The factory setting for the “swing number” is 2. This represents a temperature variation of +/- 2° F (1° C) between SET temperature and ROOM temperature, which determines when the fireplace will be activated. This function is pre-set at the factory.

The transmitter has ON and OFF manual functions that are activated by pressing either button on the face of the transmitter. When a button on the transmitter is pressed the word ON or OF will appear on the LCD screen to show while the signal is being sent. Upon initial use, there may be a delay of three seconds before the remote receiver will respond to the transmitter. This is part of the system’s design.

REMOTE RECEIVER

THE REMOTE RECEIVER SHOULD BE POSITIONED WHERE AMBIENT TEMPERATURES DO NOT EXCEED 130° F.

The remote receiver operates on (4) AA-size 1.5V batteries. It is recommended that ALKALINE batteries be used for longer battery life and maximum microprocessor performance. **IMPORTANT:** New or fully charged batteries are essential for proper operation of the remote receiver.

The remote receiver houses the microprocessor that responds to commands from the transmitter to control system operation. It emits one beep when it receives an ON or OFF command manually, but no beep when cycling ON and OFF automatically in THERMO mode. The remote receiver has a 3-position slide switch for selecting the MODE of operation: ON/REMOTE/OFF

- With the slide switch in the ON position (toward the LEARN button), the system will remain ON until the slide switch is placed in the OFF or REMOTE position.
- With the slide switch in the REMOTE position (centered), the system will only operate if the remote receiver receives commands from the transmitter.
- With the slide switch in the OFF position (away from the LEARN button), the system is OFF.
- The slide switch be placed in the OFF position if you will be away from your home for an extended period of time. If the remote receiver is mounted out of children’s reach, placing the slide switch in the OFF position also functions as a safety “lock-out” by both turning the system off and rendering the remote receiver inoperative.

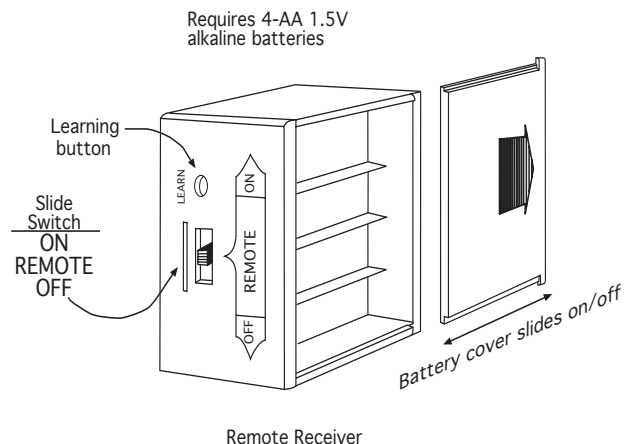

NOTE: This product is designed for use with an attended hearth appliance or fire feature. Adults must be present when the Control System is operating. DO NOT program or thermostatically set this Control to operate a hearth appliance or fire feature when Adults are not physically present. Furthermore, DO NOT leave the hearth appliance or fire feature burning unattended; it may cause damage or serious injury. If an Adult is going to be away from the hearth appliance or fire feature for any length of time, then the handheld/wall mount, receiver/control module and application should be in the “OFF” position.

INSTALLATION

The remote receiver can be mounted on or near the fireplace hearth. **PROTECTION FROM EXTREME HEAT IS VERY IMPORTANT.** Like any piece of electronic equipment, the remote receiver should be kept away from temperatures exceeding 130° F inside the receiver case. Battery life is also significantly shortened if batteries are exposed to high temperatures.

HEARTH MOUNT

The remote receiver can be placed on the fireplace hearth or under the fireplace, behind the control access panel. Position where the ambient temperature inside the receiver case does not exceed 130° F.

NOTE: Black slide button (accessory pack) is used on Hearth Mount Applications.

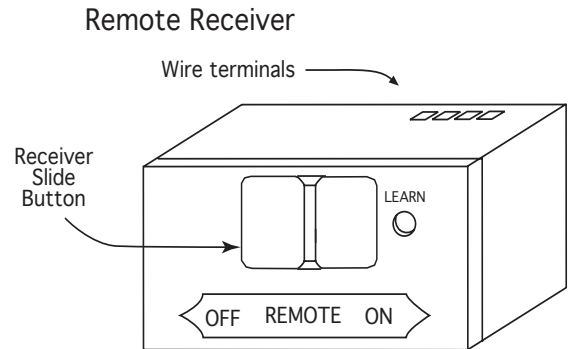

INSTALLATION

The remote receiver can be either wall-mounted in a standard plastic switch box or placed on or near the fireplace hearth. Preferably, the remote receiver should be wall-mounted in a plastic switch box, as this will protect its electronic components from both the heat produced by the gas appliance and potential damage or abuse that can occur if it is left exposed on the hearth. **PROTECTION FROM EXTREME HEAT IS VERY IMPORTANT.** Like any piece of electronic equipment, the remote receiver should be kept away from temperatures exceeding 1300 F inside the receiver case. Battery life is also significantly shortened if batteries are exposed to high temperatures.

Make sure the remote receiver switch is in the OFF position. It is recommended that 18 gauge solid or stranded wires (included) be used to make connections between the terminal wiring block on the millivolt gas valve or electronic module and the wire terminals on the remote receiver. For the best results, use 18 gauge stranded wire, with no splices and measuring no longer than 20-feet.

WALL MOUNTING RECEIVER

Install (4) AA-size 1.5 ALKALINE batteries in the remote receiver. For best performance, remote receiver batteries should be factory fresh when installed. Very little battery power is required to operate the remote receiver, but the electronics are tuned to operate best when battery output is greater than 5.3 volts. Four new AA batteries should provide an output voltage of 6.0 to 6.2 volts. Be sure batteries are installed with the (+) and (-) ends facing the correct direction.

To attach Cover Plate to Receiver Box:

Position the receiver as shown in diagram to the left with lower tab on cover plate inserted into groove of receiver (Make sure LEARN hole on cover plate properly aligns with remote receiver) Pull Receiver up and snap into top tab of cover plate.

Position the cover plate so the word ON is facing up; then, install the remote receiver into the plastic switch box using the two long screws provided. Push the white slide button over the receiver slide switch only after making sure the remote receiver has LEARNED the transmitter's security code (see LEARNING TRANSMITTER TO RECEIVER).

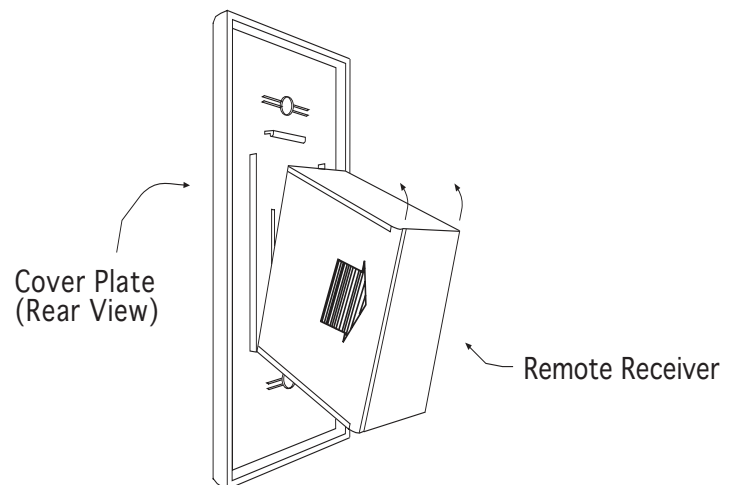

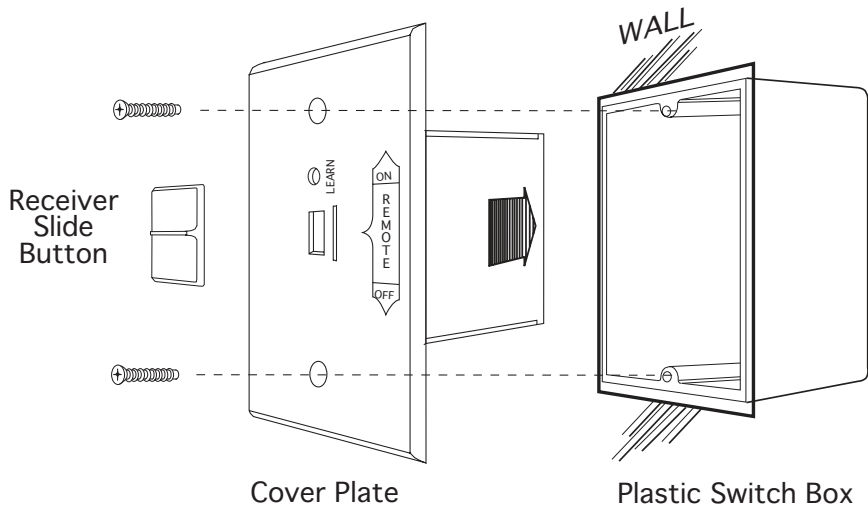

NOTE: The remote receiver will only respond to the transmitter when the 3-position slide button on the remote receiver is in the REMOTE position. If the system does not respond to the battery transmitter on initial use, see LEARNING TRANSMITTER TO RECEIVER, and recheck battery positions in the remote receiver.

WIRING INSTRUCTIONS

A qualified electrician or a gas technician who is familiar with the gas appliance and gas valves that will be operated by this remote should install the remote control system. Incorrect wiring connections WILL cause damage to the gas valve or electronic module operating the gas appliance and may also damage the remote receiver.

WIRING MILLIVOLT VALVES

The remote receiver is connected to the millivolt valve using the TH (thermostat) terminals on the terminal block on the millivolt gas valve. Connect 18 gauge solid or stranded wires from the remote receiver to the gas valve.

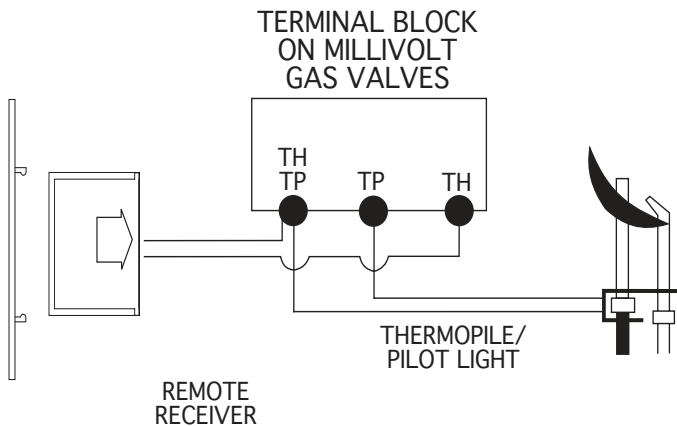

Operation of the remote receiver is similar to that of a thermostat in that both turn the gas valve ON and OFF based on input signals. A thermostat's input signals are different temperatures. The remote receiver's input signals come from the transmitter.

Connect each of the two wires leading from the TH terminals on the millivolt gas valve to either of the two wire terminals on the remote receiver. Normally it does not matter which wires go to which terminal.

WIRING ELECTRONIC SPARK IGNITIONS

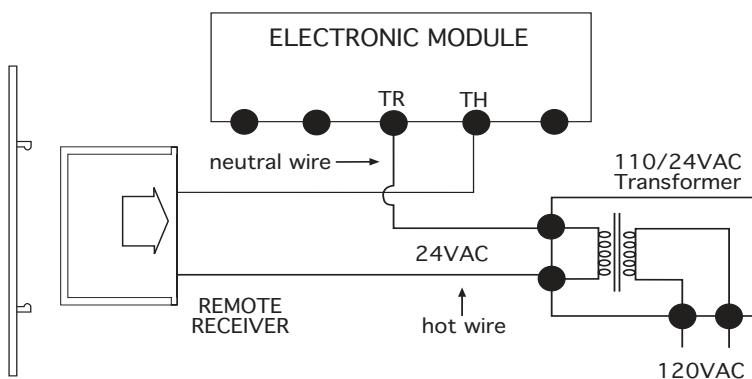

The remote control receiver can be connected, in series, to a 24VAC transformer to the TR (transformer) terminal on the ELECTRONIC MODULE. Connect the hot wire from the 24VAC transformer to either of the wire terminals on the remote receiver. Connect another wire (not included) between the other receiver wire terminal and the TH (thermostat) terminal on the ELECTRONIC MODULE.

SYSTEM CHECK

MILLIVOLT VALVES

Light your gas appliance following the lighting instructions that came with the appliance. Confirm that the pilot flame is ON; it must be in operation for the main gas valve to operate.

- Slide the 3-position button on the remote receiver to the ON position. The main gas flame (i.e., the fire) should ignite.
- Slide the button to OFF. The flame should extinguish (the pilot flame will remain ON).
- Slide the button to REMOTE (the center position), and then press the ON button on the transmitter to turn the system to ON. The main gas flame should ignite.
- Press the OFF button on the transmitter to turn the system to OFF. The flame should extinguish (the pilot flame will remain on).
- Press the MODE button on the transmitter to change the system to THERMO. Advance the SET temperature on the transmitter to a temperature of at least 2°F (1°C) above the ROOM temperature displayed on the LCD screen. With this manual setting, the normal thermostatic cycle is overridden and the system flame will ignite. Set the SET
- temperature to at least 2°F (1°C) below the room temperature and the system flame will extinguish in a few seconds. Thereafter, it should continue to cycle ON and OFF thermostatically approximately every two minutes as the ROOM temperature changes, but only when the temperature differential between ROOM and SET temperatures differ at least 2°F (1°C). The 2° F differential is the factory setting.

ELECTRONIC IGNITION SYSTEMS

- Slide the 3-position button on the remote receiver to the ON position. The spark electrode should begin sparking to ignite the pilot (the pilot may ignite after only one spark). After the pilot flame is lit, the main gas valve should open and the main gas flame should ignite.
- Slide the button to OFF. The main gas flame and pilot flame should BOTH extinguish.
- Slide the button to REMOTE (the center position), and then press the ON button on the transmitter to turn the system to ON. The spark electrode should begin sparking to ignite the pilot. After the pilot is lit, the main gas valve should open and the main gas flame should ignite.
- Press the OFF button on the transmitter to OFF. The main gas flame and pilot flame should BOTH extinguish.
- Press the MODE button on the transmitter to change the system to THERMO. Advance the SET temperature on the transmitter to a temperature of at least 2°F (1°C) above the ROOM temperature displayed on the LCD screen. With this manual setting the normal thermostatic cycle is overridden and the system flame will ignite. Set the SET
- temperature to at least 2°F (1°C) below the room temperature and the system flame will extinguish in a few seconds. Thereafter, it should continue to cycle ON and OFF thermostatically approximately every two minutes as the ROOM temperature changes, but only when the temperature differential between ROOM and SET temperatures differ at least 2°F (1°C). (The 2°F differential is the factory setting).

CP (CHILDPROOF) FEATURE

This remote control includes a CHILDPROOF “LOCK-OUT” feature that allows the user to “LOCK-OUT” operation of the appliance, from the TRANSMITTER.

SETTING CHILDPROOF “LOCK-OUT” –(CP)

- To activate the “LOCK-OUT” feature, press and hold the ON button and the MODE button at the same time for 5 seconds. The letters CP will appear in the TEMP frame on the LCD screen.
- To disengage the “LOCK-OUT”, press and hold the ON button and the MODE button at the same time for 5 seconds and the letters CP will disappear from the LCD screen and the transmitter will return to its normal operating condition.
- To verify that transmitter is in the CP lock-out mode press any key and the LCD screen will show “CP”

NOTE: If the appliance is already operating in the ON or THERMO MODES, engaging the “LOCK-OUT” will not cancel the operating MODE. Engaging the “LOCK-OUT” prevents only the manual operation of the TRANSMITTER. If in the auto modes, the THERMO operation will continue to operate normally. To totally “LOCK-OUT” the operation of the TRANSMITTER’S operating signals; the transmitter’s MODE must be set to OFF.

THERMO UPDATING FEATURE –TRANSMITTER – (T/S –TX)

This remote control has a THERMO UPDATING Feature built into its software. The THERMO UPDATING Feature operates in the following manner, but only in the THERMO MODES:

The transmitter reads the ROOM temperature every 2 minutes checking the ROOM temperature against the SET temperature and then sends a signal to the receiver.

COMMUNICATION SAFETY – TRANSMITTER – (C/S – TX)

This remote control has a COMMUNICATION –SAFETY function built into its software. It provides an extra margin of safety when the TRANSMITTER is out of the normal 20-foot operating range of the receiver.

The COMMUNICATION – SAFETY feature operates in the following manner, in all OPERATING MODES – ON/ ON THERMO.

At all times and in all OPERATING MODES, the transmitter sends an RF signal every fifteen (15) minutes, to the receiver, indicating that the transmitter is within the normal operating range of 20-feet. Should the receiver NOT receive a transmitter signal every 15 minutes, the IC software, in the RECEIVER, will begin a 2-HOUR (120-minute) countdown timing function. If during this 2-hour period, the receiver does not receive a signal from the transmitter, the receiver will shut down the appliance being controlled by the receiver. The RECEIVER will then emit a series of rapid “beeps” for a period of 10 seconds. Then after 10 seconds of rapid beeping, the RECEIVER will continue to emit a single “beep” every 4 seconds until a transmitter ON or MODE Button is pressed to reset the receiver. The intermittent 4-second beeping will go on for as long as the receiver’s batteries last which could be in excess of one year.

To “reset” the RECEIVER and operate the appliance, you must press the ON or MODE button on the transmitter. By turning the system to ON, the COMMUNICATION -SAFETY operation is overridden and the system will return to normal operation depending on the MODE selected at the transmitter. The COMMUNICATION – SAFETY feature will reactivate should the transmitter be taken out of the normal operating range or should the transmitter’s batteries fail or be removed.

LEARNING TRANSMITTER TO RECEIVER

Each transmitter uses a unique security code. It will be necessary to press the LEARN button on the receiver to accept the transmitter security code upon initial use, if batteries are replaced, or if a replacement transmitter is purchased from your dealer or the factory. In order for the receiver to accept the transmitter security code, be sure the slide button on the receiver is in the REMOTE position; the receiver will not LEARN if the slide switch is in the ON or OFF position. The LEARN button is located on the front face of the receiver; inside the small hole labeled LEARN. Using a small screwdriver or end of a paper clip gently press and release the black LEARN button inside the hole. When you release the LEARN button the receiver will emit an audible “beep”. After the receiver emits the beep press the transmitter ANY button and release. The receiver will emit several beeps indicating that the transmitter’s code has been accepted into the receiver.

The microprocessor that controls the security code matching procedure is controlled by a timing function. If you are unsuccessful in matching the security code on the first attempt, wait 1 - 2 minutes before trying again--this delay allows the microprocessor to reset its timer circuitry--and try up to two or three more times.

BATTERY LIFE

Life expectancy of alkaline batteries in the 1001TH-A should be at least 12 months. Check and replace all batteries annually. When the transmitter no longer operates the remote receiver from a distance it did previously (i.e., the transmitter’s range has decreased) or the remote receiver does not function at all, the batteries should be checked. It is important that the remote receiver batteries are fully charged, providing combined output voltage of at least 5.3 volts. The transmitter should operate with as little as 2.5 volts battery power.

TRANSMITTER WALL CLIP

The transmitter can be hung on a wall using the clip provided. If the clip is installed on a solid wood wall, drill 1/8" pilot holes and install with the screws provided. If it is installed on a plaster/wallboard wall, first drill two 1/4" holes into the wall. Then use a hammer to tap in the two plastic wall anchors flush with the wall; then install the screws provided.

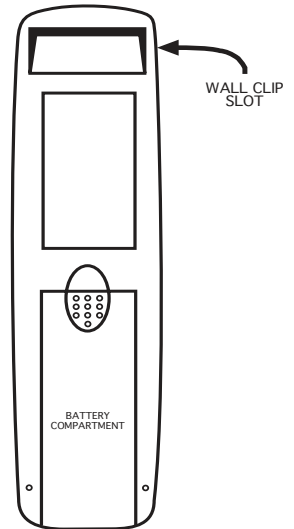
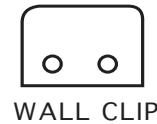

TROUBLE SHOOTING

If you encounter problems with your fireplace system, the problem may be with the fireplace itself or it could be with the 1001TH-A remote system. Review the fireplace manufacturer's operation manual to make sure all connections are properly made. Then check the operation of the remote in the following manner:

- Make sure the batteries are correctly installed in the RECEIVER. One reversed battery will keep receiver from operating properly.
- Check battery in TRANSMITTER to ensure contacts are touching (+) and (-) ends of battery. Bend metal contacts in for tighter fit.
- Be sure RECEIVER and TRANSMITTER is within 20 – 25-foot operating range.
- Keep RECEIVER from temperatures exceeding 130° F. Battery life shortened when ambient temperatures are above 115° F.
- If RECEIVER is installed in tightly enclosed metal surround, the operating distance will be shortened.

NOTE: A receiver located in an area, where the ambient temperature inside the case exceeds 130° F, will cause the THERMO-SAFETY feature to cut in, requiring you to reposition the receiver to stop the warning beeps, and to "reset" the receiver's operation.

SPECIFICATIONS

BATTERIES: Transmitter (2) 1.5 volt AAA t batteries
Remote Receiver 6V - 4 ea. AA 1.5 Alkaline

FCC ID No.'s: transmitter - K9LSP1001TH; receiver - K9L330IRX

Operating Frequency: 303.8 MHZ

Canadian IC ID No.'s: transmitter – 2439A-SP1001TH; receiver – 2439A-3301RX

FOR TECHNICAL SERVICE CALL:

US Inquires
(855) 498-8324 or (260) 459-1703

Canadian Inquires
(877) 472-3923

For Sales: (888) 672-8929
Website: www.skytechpg.com

LIMITED WARRANTY

1. **Limited Warranty.** Skytech II, Inc. ("Skytech") warrants that each new Skytech Control System, including all hardware, parts and components (the "System"), when used in accordance with the instructions furnished by Skytech provided with each System, shall be free in all material respects, of defects in materials and any workmanship under normal use, subject to proper installation ("Limited Warranty"). This Limited Warranty is non-transferrable and sets forth our sole and exclusive liability and the sole and exclusive remedies available in relationship to any non-conformity, defect or similar claim. This Limited Warranty only extends to the original retail purchaser of the System (the "Customer") and expires upon any sale or transfer of the home where the System is installed by the Customer.
2. **System Sold As Is.** Subject to this Warranty and any applicable state law, each System is sold by Skytech to a Customer on an "as is" basis. In addition, each System and Skytech's obligations are and remain subject to all additional disclaimers, limitations, reservations of rights, exclusions, and qualifications set forth on Skytech's website, www.skytechpg.com, all of which are considered part of the Warranty and are incorporated herein (collectively, the "Additional Terms"). Each Customer, by purchasing and/or using any System or any portion thereof, does so subject to the Warranty and the Additional Terms.
3. **Installation and Use of System.** Improper Installation, adjustment, alteration, service, or maintenance can cause property damage, personal injury, or loss of life. Thoroughly read the installation and operating instructions of this Control as well as the appliance it will be used in conjunction with as a system. If applicable, read the maintenance instructions before installing this control. This product is designed for use with an attended hearth appliance or fire feature. Adults must be present when the Control System is operating. DO NOT program or thermostatically set this Control to operate a hearth appliance or fire feature when Adults are not physically present. Furthermore, DO NOT leave the hearth appliance or fire feature burning unattended; it may cause damage or serious injury. If an Adult is going to be away from the hearth appliance or fire feature for any length of time, then the handheld/wall mount, receiver/control module and application should be in the "OFF" position.
4. **Repair or Replacement of System or Parts.** Should any System, or any hardware, components and/or parts contained therein fail due to a defect in workmanship or material provided by Skytech after the purchase of a System by a Customer, Skytech shall repair or, at its option, replace the defective System or part, hardware or component, subject to the Customer's compliance with all terms and conditions contained herein governing service and claims under the Warranty. Skytech shall provide replacement parts at no charge for the first (5) five years of this warranty, and at market cost for the Lifetime of the product to the original Customer. Gas valve and gas valve components will be available at no charge for one (1) year. If Skytech does not have the parts for an individual model, then a comparable replacement System will be provided at no charge within the first (5) five years after purchase, and then at market cost for the Lifetime of that product to the Customer.
5. **Warranty Claims; Skytech Service.** To submit a valid claim under the Warranty (each, a "Valid Claim"), a Customer must comply with the following:
 - a) Obtain a Return Material Authorization ("RMA") number from Skytech by calling (855) 498-8324; and
 - b) Provide written notice to a Skytech or an Authorized Dealer ("Dealer") and provide the Name, House Address, Email Address and Telephone Number of the Customer;
 - c) Describe the System model number and nature of the defect, nonconformity, or other problem with the System;
 - d) Provide such notice within thirty (30) days of discovery of such defect, nonconformity, or problem;
 - e) securely pack and ship the defective Skytech Product to Skytech II, Inc. ATTN: Warranty Department at 9230 Conservation Way, Fort Wayne, IN 46809. Customer assumes all costs and risks associated with transportation to Skytech (i) the RMA number is only valid for thirty (30) days from the date the RMA was issued, (ii) the RMA number should be clearly marked on the outside of each box being returned. Skytech may refuse shipments that DO NOT meet all of the Valid Claim requirements. Skytech is not responsible for any refused shipments or any damage caused due to shipping, whether or not it was a Valid Claim. Skytech shall be responsible for return shipment charges. Compliance with these requirements is a condition to coverage under this Limited Warranty.

Skytech may refuse any shipment(s) that does not meet all of the Valid Claim requirements. Skytech is not responsible for any refused shipments or any damage caused due to shipping, whether or not it was a Valid Claim. Skytech shall be responsible for reasonable return shipment charges for any Skytech System returned whether or not Skytech determines there is no defect with the System, reject for failure of the Customer to submit a Valid Claim, or otherwise determine is not eligible for service under the Warranty.

Upon receipt of a Valid Claim and the properly-returned System, Skytech shall, at its option, either (a) repair the System, at no charge to the Customer, or (b) replace the returned System with a new comparable System, at no charge to the Customer, or (c) provide the Customer with a refund in an amount equal to the price paid by the Customer for the defective System not including any service or labor cost associated with the installation or otherwise. Any System or

hardware, component or part repaired by Skytech hereunder, or any replacement System, hardware, component or part shall be shipped to the Customer by Skytech at Skytech's cost and the Warranty, the Additional Terms, and all other terms and conditions set forth herein shall extend to such repaired or replacement System, hardware, component or part. Skytech shall pay no refund before Skytech from the Customer receives the defective System, hardware, component and/or parts. Any obligation of Skytech under this Section 4 shall be and remain subject to Skytech's right to physically inspect the defective System, hardware, component and/or part returned to Skytech by the Customer. Some States do not allow the exclusion or limitation of incidental and consequential damages or limitation on how long an implied warranty lasts, so the above limitation may not apply to you. This warranty gives you specific rights and you may have other rights, which vary from state, province, or nation. To the extent allowable under any law, the liability of Skytech is limited to the express terms of this warranty, and Skytech expressly disclaims any and all implied warranties, including any warranties of fitness for a particular purpose or merchantability

REV. 2-24-17



Print information and detach at dotted line for return to: Skytech, ATTN WARRANTY DEPT., 9230 Conservation Way, Fort Wayne, IN 46809
Telephone: (855) 498-8324

Warranty Information

Purchase Date: _____ Model: _____ Date Code: _____

Purchased From: _____

Customer Name: _____ Phone: _____

Address: _____

Email Address: _____

City: _____ State/Prov. _____ Zip/Postal Code: _____

Back of remote Date Code Sample

16'	●	1	2	3	4	5	6
17'		7	8	9	10	●	12

1-12 is Month remote was produced
15-16 is Year remote was produced
Sample date code above is 1611

Please send a Proof of Purchase (original receipt) copy along with your Warranty form.

Santa's Helper

Exclusive offer to Skytech Remote Control Owners

This special offer is only provided to customers of Skytech that have purchased a remote control for their Hearth Product. This remote control system can be used for any 120VAC appliance, but perfect your Christmas Tree Lights or any other appliance that is difficult to reach or plug in. Simply plug the receiver into your wall outlet and your appliance into the receiver, push the ON button on the transmitter and you are in business. It's that easy!



The list price of **\$48.00** for the Santa's Helper has been cut almost in half to **\$20.00 USD** for this exclusive offer. Shipping and handling of **\$5.00 USD** should be added. Send us your check, money order or call us with your credit card number, along with the warranty information from your remote control of your Hearth Product. You can also send it via mail, fax, or e-mail.

Skytech Products Group
9230 Conservation Way
Fort Wayne, IN 46809
1-(888) 672-8929
1-(888) 672-8024 Fax
E-mail : order@skytechpg.com