



MID 100A SERIES

DIN rail smart meters for single and three phase electrical systems

User manual v1.0

1 Introduction

This document provides operating, maintenance and installation instructions. These units measure and display the characteristics of single phase two wires (1p2w), three phase three wires (3p3w) and three phase four wires (3p4w) networks. The measuring parameters include voltage (V), frequency (Hz), current (A), power (kW/kVa/kVar), import, export and total Energy (kWh/kVarh). The units can also measure Maximum demand current and power, this is measured over preset periods of up to 60 minutes.

These units are max 100A direction operated and do not need to connect with external current transformers (CT). Built-in pulse, RS485 Modbus RTU/Mbus outputs. Configuration is password protected.

1.1 Unit characteristics

The Smappee MID 100A SERIES meters have seven models, 1 is used:

Model	Measurement	Output	Tariff
i1-EN3-1	kWh/kVarh, kW/kVar, kVA, P, F, PF, dmd, V, A, THD...	pulse/Modbus	-

1.2 RS485 serial Modbus RTU

RS485 serial port with Modbus RTU protocol to provide a means of remotely monitoring and controlling the Unit. Set-up screens are provided for setting up the RS485 port.

1.3 Mbus

This uses an Mbus port with EN13757-3 protocol to provide a means of remotely monitoring and controlling the Unit. Set-up screens are provided for setting up the Mbus port.

1.4 Pulse output

Two pulse outputs that pulse measured active and reactive energy. The constant of pulse output 2 for active energy is 400imp/kWh (unconfigurable), its width is fixed at 100ms. The default constant of configurable pulse output 1 is 400imp/kWh, default pulse width is 100ms. The configurable pulse output 1 can be set from the set-up menu.

2 Start-up screens

The first screen lights up all display segments and can be used as a display check.

Software version information.

The interface performs a self-test and indicates the result if the test passes.

After a short delay, the screen will display active energy interface as follows:

Total active energy in kWh.

3 Measurements

The buttons operate as follows:

- U/I** Selects the Voltage and Current display screens. In Set-up mode, this is the "Left" or "Back" button.
- M** Select the Frequency and Power factor display screens. In Set-up mode, this is the "Up" button.
- P** Select the Power display screens. In Set-up mode, this is the "Down" button.
- E** Select the Energy display screens. In Set-up mode, this is the "Enter" or "Right".

3.1 Voltage and current

Each successive press of the **U/I** button selects a new parameter:

Phase to neutral voltages.

Current on each phase.

Phase to neutral voltage THD% of 2nd to 19th.

Each phase Current THD% of 2nd to 19th.

3.2 Frequency, power factor and demand

Each successive press of the **M** button selects a new range:

Frequency and Power Factor (total).

Power Factor of each phase.

Maximum Power Demand.

Maximum Current Demand.

3.3 Power

Each successive press of the **P** button selects a new range:

Instantaneous Active Power in kW.

Instantaneous Reactive Power in kVar.

Instantaneous Volt-Amps in KVA.

Total kW, kVarh, kVA.

3.4 Energy measurements

Each successive press of the **E** button selects a new range:

Import active energy in kWh.

Export active energy in kWh.

Total active energy in kWh.

Import reactive energy.

Export reactive energy.

Total reactive energy.

*The date and time can only be set via RS485 communication.

4 Set-up

To enter set-up mode, press the **E** button for 3 seconds, until the password screen appears.

Setting up is password-protected so you must enter the correct password (default 1000) before processing. Press the **E** button for 3 seconds to confirm.

If an incorrect password is entered, the display will show: PASS Err

To exit setting-up mode, press **U/I** repeatedly until the measurement screen is restored.

4.1 Set-up entry methods

Some menu items, such as password, require a four-digits number entry while others, such as supply system, require selection from a number of menu options.

4.1.1 Menu option selection

- Use the **M** and **P** buttons to scroll through the different options of the set-up menu.
- Press **E** to confirm your selection.
- If an item flashes, then it can be adjusted by the **M** and **P** buttons.
- Having selected an option from the current layer, press **E** to confirm your selection. The SET indicator will appear.
- Having completed a parameter setting, press **U/I** to return to a higher menu level. The SET indicator will be removed and you will be able to use the **M** and **P** buttons for further menu selection.
- On completion of all setting-up, press **U/I** repeatedly until the measurement screen is restored.

4.1.2 Number entry procedure

When setting up the unit, some screens require the entering of a number. In particular, on entry to the setting up section, a password must be entered. Digits are set individually, from left to right. The procedure is as follows:

- The current digit to be set flashes and is set using the **M** and **P** buttons.
- Press **E** to confirm each digit setting. The SET indicator appears after the last digit has been set.
- After setting the last digit, press **U/I** to exit the number setting routine. The SET indicator will be removed.

4.2 Change password

Use **M** and **P** to choose the change password option.

Press **E** to enter the change password routine. The new password screen will appear with the first digit flashing.

Use **M** and **P** to set the first digit and press **E** to confirm your selection. The next digit will flash.

Repeat the procedure for the remaining three digits.

After setting the last digit, SET will show.

Press **U/I** to exit the number setting routine and return to the Set-up menu. SET will be removed.

4.3 Supply system

*The unit has a default setting of 3Phase 4wire (3P4). Use this section to set the type of electrical system.

From the set-up menu, use **M** and **P** to select the system option. The screen will show the currently selected power supply.

Press **E** to enter the selection routine. The current selection will flash.

Use **M** and **P** to select the required system option: 1P2 (W), 3P3 (W), 3P4 (W).

Press **E** to confirm the selection. SET indicator will appear.

Press **U/I** to exit the system selection routine and return to the menu. SET will disappear and you will be returned to the main set-up Menu.

4.4 Backlit set-up

Backlit lasting time is settable, default is 60minutes.

If it's setted as 5, the backlit will be off in 5 minutes if there is no more further operation.

Press **E** to enter the selection routine. The current time interval will flash. The options are: 0 (always on) /5/10/30/60/120

Press **M** and **P** to select the time interval. Then press **E** to confirm the set-up.

4.5 Communication

There is RS485/Mbus port can be used for communication Modbus RTU protocol. For Modbus RTU, parameters are selected from front panel.

The first screen below shows a range from 001 to 247.

From the set-up menu, use **M** and **P** to select the address ID.

Press **E** to enter the selection routine. The current setting will flash.

Use **M** and **P** to choose Modbus address (001 to 247).

On completion of the entry procedure, press **E** to confirm the setting and press **U/I** to return to the main set-up menu.

4.6 Demand integration time (DIT)

This sets the period in minutes over which the current and power readings are integrated for maximum demand measurement. The options are: 0, 5, 8, 10, 15, 20, 30, 60 minutes.

From the set-up menu, use **M** and **P** to select the DIT option. The screen will show the currently selected integration time.

Press **E** to enter the selection routine. The current time interval will flash.

Use **M** and **P** to select the time required.

Press **ENT** to confirm the selection. **SET** indicator will appear.

Press **UI** to exit the DIT selection routine and return to the menu.

4.7 Demand integration time (DIT)

This sets the period in minutes over which the current and power readings are integrated for maximum demand measurement. The options are: 0, 5, 8, 10, 15, 20, 30, 60 minutes.

From the set-up menu, use **M** and **P** to select the DIT option. The screen will show the currently selected integration time.

Press **ENT** to enter the selection routine. The current time interval will flash.

Use **M** and **P** to select the time required.

Press **ENT** to confirm the selection. **SET** indicator will appear.

Press **UI** to exit the **DIT** selection routine and return to the menu.

4.8 CLR

The meter provides a function to reset the maximum demand value of current and power.

From the set-up menu, use **M** and **P** to select the reset option.

Press **ENT** to enter the selection routine. The **MD** will flash.

Press **ENT** to confirm the setting and press **UI** to return to the main set-up menu.

4.9 Pulse output

This option allows you to configure the pulse output 1. The output can be set to provide a pulse for a defined amount of energy active or reactive. Use this section to set up the pulse output for:

- Total kWh/Total kVarh
- Import kWh/Export kWh
- Import KVarh/Export KVarh

From the set-up menu, use **M** and **P** to select the Pulse output option.

Press **ENT** to enter the selection routine. The unit symbol will flash.

Use **M** and **P** to choose kWh or kVarh.

On completion of the entry procedure, press **ENT** to confirm the setting and press **UI** to return to the main set up menu.

4.9.1 Pulse rate

Use this to set the energy represented by each pulse. Rate can be set to 1 pulse per dFt/0.01/0.1/1/10/100 kWh/kVarh. The first screen below shows 1 pulse = 10kWh/kVarh.

From the set-up menu, use **M** and **P** to select the Pulse rate option.

Press **ENT** to enter the selection routine. The current setting will flash. When it's dFt (default), it means 2.5Wh/Varh.

Use **M** and **P** to choose pulse rate. On completion of the entry procedure, press **ENT** to confirm the setting and press **UI** to return to the main set-up menu.

4.9.2 Pulse duration

The pulse width can be selected as 200ms (non-MID version meters only), 100ms (default) or 60ms. The first screen below shows default pulse width.

From the set-up menu, use **M** and **P** to select the Pulse width option.

Press **ENT** to enter the selection routine. The current setting will flash.

Use **M** and **P** to choose pulse width. On completion of the entry procedure, press **ENT** to confirm the setting and press **UI** to return to the main set-up menu.

5 Specifications

5.1 Measured parameters

The unit can monitor and display the following parameters of a single phase two wire (1p2w), three phase three wire (3p3w) or three phase four wire (3p4w) system.

5.1.1 Voltage and current

- Phase to neutral voltages 176 to 276V a.c. (not for 3p3w supplies).
- Voltages between phases 304 to 480V a.c. (3p supplies only).
- Percentage total voltage harmonic distortion (THD%) for each phase to N (not for 3p3w supplies).
- Percentage voltage THD% between phases (three phase supplies only).
- Current THD% for each phase.

5.1.2 Power factor, frequency and max demand

- Frequency in Hz
- Instantaneous power:
 - Power 0 to 99999 W
 - Reactive power 0 to 99999 Var
 - Volt-amps 0 to 99999 VA
- Maximum demanded power since last Demand reset
- Power factor
- Maximum neutral demand current, since the last Demand reset (for three phase supplies only)

5.1.3 Energy measurements

- Import active energy: 0 to 999999.99 kWh
- Export reactive energy: 0 to 999999.99 kVarh
- Import active energy: 0 to 999999.99 kWh
- Export reactive energy: 0 to 999999.99 kVarh
- Total active energy: 0 to 999999.99 kWh
- Total reactive energy: 0 to 999999.99 kVarh

5.2 Measured inputs

Voltage inputs through 4-way fixed connector with 25mm² stranded wire capacity, single phase two wire (1p2w), three phase three wire (3p3w) or three phase four wire (3p4w) unbalanced. Line frequency measured from L1 voltage or L3 voltage.

5.3 Interfaces for external monitoring

Three interfaces are provided:

- RS485/Mbus communication channel that can be programmed via protocol remotely. (not for SDM630-Pulse V2)
- Pulse output (pulse1) indicating real-time measured energy (configurable)
- Pulse output (pulse2) 400imp/kWh (not configurable)

The Modbus/Mbus configuration (baud rate, etc) and the pulse relay output assignments (kW/kVarh, import/export, etc) are configured through the set-up screens.

5.3.1 Pulse output

The pulse output can be set to generate pulses to represent kWh or kVarh. Rate can be set to generate 1 pulse per:

- dFt = 2.5 Wh/Varh (default)
- 0.01 = 10 Wh/Varh
- 0.1 = 100 Wh/Varh
- 1 = 1 kWh/kVarh
- 10 = 10 kWh/kVarh
- 100 = 100 kWh/kVarh

Pulse width: 200/100/60 ms

Pulse output 2 is non-configurable. It is fixed up with active kWh. Its constant is 400imp/kWh.

5.3.2 RS485/Mbus output for communication

For Modbus RTU, the following RS485 communication parameters can be configured from the set-up menu:

- Baud rate: 2400, 4800, 9600, 19200, 38400
- Parity: none, odd, even
- Stop bits: 1 or 2
- RS485 network address (Inn): 001 to 247

If the Modbus/Mbus protocol document is required, please contact us.

5.4 Accuracy

- Voltage: 0.5 % of range maximum
- Current: 0.5 % of nominal
- Frequency: 0.2 % of mid-frequency
- Power factor: 1 % of unity (0.01)
- Active power (W): ± 1 % of range maximum
- Reactive power (VAR): ± 1 % of range maximum
- Apparent power (VA): ± 1 % of range maximum
- Active energy (Wh): Class 1 IEC 62053-21, Class B EN504 70-3
- Reactive energy (VARh): ± 1 % of range maximum
- Response time to step input: 1s, typical, to >99% of final reading, at 50 Hz

5.5 Reference conditions of influence

quantities

Influence Quantities are variables that affect measurement errors to a minor degree. Accuracy is verified under nominal value (within the specified tolerance) of these conditions.

- Ambient temperature: 23°C ± 2°C
- Input frequency: 50 Hz (MID), 50 or 60Hz ± 2% (non-MID) Sinusoidal (distortion factor < 0.005)
- Input waveform: Sinusoidal
- Magnetic field of ext. origin: Terrestrial flux

5.6 Environment

- Operating temperature: -25°C to +55°C*
- Storage temperature: -40°C to +70°C*
- Relative humidity: 0 to 95%, non-condensing
- Altitude: Up to 2000m
- Warm up time: 1 minute
- Vibration: 10Hz to 50Hz, IEC 60068-2-6, 2g
- Shock: 30g in 3 planes

*Maximum operating and storage temperatures are in the context of typical daily and seasonal variation.

5.7 Mechanics

- DIN rail dimensions: 72x100mm (WxH) per DIN 43880
- Mounting: DIN rail (DIN 43880)
- Sealing: IP51 (indoor)
- Material: Self-extinguishing UL94 V-0

5.8 Reference conditions of influence

quantities

We, Smappee n.v., Declare under our sole responsibility as the manufacturer that the poly phase multifunction electrical meter "SMAPPEE MID 100A series" correspond to the production model described in the EU-type examination certificate and to the requirements of the Directive 2014/32/EU EU type examination certificate number 0120/SGS0462.

Identification number of the NB0120.

6 Dimensions

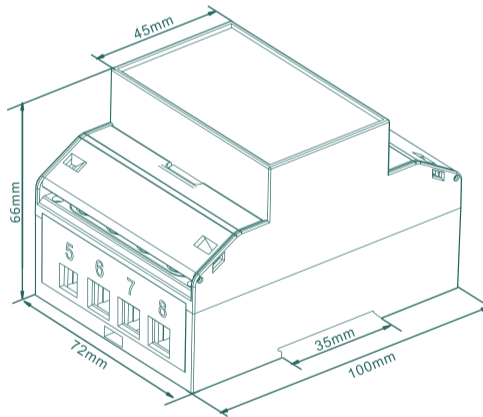

7 Wiring diagram

Interface for external monitoring:



7.1 Single phase two wires (1P2)

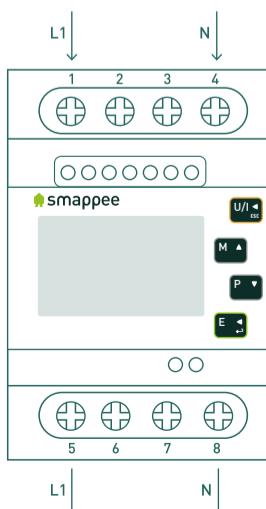

7.2 Three phase three wires (3P3)

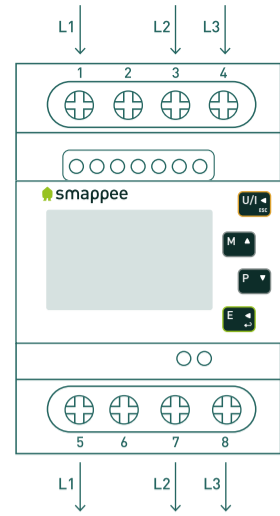

7.3 Three phase four wires (3P4)

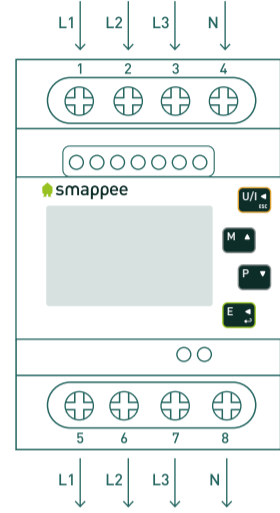

Safety warnings

Important Safety Information is contained in the Maintenance section. Familiarize yourself with this information before attempting installation or other procedures.

Symbols used in this document:

- Risk of Danger:** These instructions contain important safety information. Read them before starting installation or servicing of the equipment.
- Caution:** Risk of Electric Shock.



Evolis 104, 8530 Harelbeke, Belgium
info@smappee.com
www.smappee.com

