



X3-Hybrid Series User Manual

5.0kW - 15.0kW



EN



SolaX Power Network Technology (Zhejiang) Co., Ltd.

ADD.: No. 288 Shizhu Road, Tonglu Economic Development Zone,
Tonglu City, Zhejiang Province, 310000 P. R. CHINA

Tel.: + 0571 - 5626 0011

E-mail: info@solaxpower.com

614.00897.00

Copyright Declaration

The copy right of this manual belongs to SolaX Power Network Technology(Zhejiang) Co., Ltd.(SolaX Power Co., Ltd.) . Any corporation or individual should not plagiarize, partially or fully copy it (including software, etc.) , and reproduction or distribution of it shall not be allowed in any form or by any means. All rights reserved. SolaX Power Network Technology (Zhejiang) Co., Ltd. reserves the right of final interpretation. The contents are subject to change without prior notice.

www.solaxpower.com



Contents

1 Note on this Manual	03
1.1 Scope of Validity.....	03
1.2 Target Group.....	03
1.3 Symbols Used.....	03
1.3.1 Important Safety Instructions.....	04
1.3.2 Explanation of Symbols.....	09
1.3.3 CE Directives.....	11
2 Introduction	12
2.1 Basic Features	12
2.2 Electrical Block Diagram of The System	12
2.3 Work Modes.....	15
2.4 Dimension	17
2.5 Terminals of Inverter.....	18
3 Technical Data	19
3.1 DC Input	19
3.2 AC Output/Input	19
3.3 Battery.....	20
3.4 Efficiency, Safety and Protection.....	20
3.5 EPS(Off-grid) Output	21
3.6 General Data.....	21
4 Installation	22
4.1 Check for Transport Damage	22
4.2 Packing List.....	22
4.3 Installation Precautions.....	24
4.4 Tool Preparation.....	25
4.5 Installation Site Conditions.....	27
4.5.1 Installation Carrier Requirements	27
4.5.2 Installation Requirements.....	27
4.5.3 Installation Space Requirements.....	28
4.6 Mounting.....	29

5 Electrical Connections.....32

5.1 PV Connection32

5.2 Grid Port and EPS(Off-grid) Output Connection..... 36

5.3 EPS(Off-grid) Block Diagram..... 37

5.4 Battery Connection.....46

5.5 Communication Connection.....50

5.5.1 Introduction to DRM Communication.....50

5.5.2 Introduction to Meter/CT Communication.....51

5.5.3 Parallel Communication.....54

5.5.4 COM Communication.....60

5.5.5 Communication Connection Steps.....62

5.6 Grounding (Mandatory).....71

5.7 Monitoring Connection.....74

5.8 Check All Below Steps Before Starting Inverter.....76

5.9 Inverter Operation.....77

6 Firmware upgrading.....79

7 Setting.....83

7.1 Control Panel.....83

7.2 Menu Structure.....84

7.3 LCD Operation.....85

8 Troubleshooting..... 111

8.1 Trouble Shooting.....111

8.2 Routine Maintenance.....118

9 Decommissioning..... 119

9.1 Disassemble the Inverter.....119

9.2 Packaging.....119

9.3 Storage and Transportation.....119

9.4 Waste Disposal119

10 Disclaimer.....120

*** WARRANTY REGISTRATION FORM**

1 Notes on this Manual

1.1 Scope of Validity

This manual is an integral part of the inverter, it describes the assembly, installation, commissioning, maintenance and failure of the product. Please read it carefully before operating.

X3-Hybrid-5.0-D	X3-Hybrid-5.0-M	X3-Hybrid-10.0-D	X3-Hybrid-10.0-M
X3-Hybrid-6.0-D	X3-Hybrid-6.0-M	X3-Hybrid-12.0-D	X3-Hybrid-12.0-M
X3-Hybrid-8.0-D	X3-Hybrid-8.0-M	X3-Hybrid-15.0-D	X3-Hybrid-15.0-M

Note: "**X3-Hybrid**" Series refers to the energy storage inverter that supports photovoltaic grid-connected.

"**5.0**" means 5.0kW.

"**D**" means "DC switch", "**M**" means externally connected.

X3-Matebox, built-in DC switch, BAT circuit breaker, AC and EPS (Off-grid)circuit breaker, which can reduce the cost of customers on accessory. And pre-installed wiring cables and device can get grid of the complicated wiring work.

The 15.0kw inverter complies with Thailand’s PEA/MEA grid-connected regulations.

Keep this manual available at any time.

1.2 Target Group

This manual is for end customers and qualified electricians. The tasks described in this manual only can be performed by qualified electricians.

1.3 Symbols Used

The following types of safety instructions and general information appear in this document as described below:

	Danger! "Danger" refers to a dangerous situation that, if not avoided, will result in a high level of risk such as serious injury or even death.
---	--

	Warning! "Warning" indicates a dangerous situation, which, if not avoided, may result in serious injury or death.
---	---

**Caution!**

"Caution" indicates a hazardous situation which, if not avoided, could result in minor or moderate injury.

**Note!**

"Note" provides tips that are valuable for the optimal operation of our product.

1.3.1 Important Safety Instructions

**Danger!****Danger to life due to high voltages in the inverter!**

The personnel responsible for the installation, electrical connection, debugging, maintenance and fault handling operation of this product need to be trained, master the correct operation method, have the corresponding electrician qualification and safety operation knowledge.

**Caution!**

When the inverter is working, it is strictly forbidden to touch the shell. The temperature of the shell is high and there is a risk of scalding.

**Caution!****Radiation may be harmful to health!**

Do not stay for a long time and keep at least 20 cm away from the inverter.

**Note!****Ground PV system.**

Finish PV modules and photovoltaic system grounding in accordance with local requirements to achieve optimal protection of systems and personnel.

**Warning!**

Ensure that the input DC voltage is below the inverter limit. Excessive DC voltage and current may cause permanent damage or other losses to the inverter, which is not covered by the warranty.

**Warning!**

Before performing maintenance, cleaning or operation on the circuit connected to the inverter, authorized maintenance personnel must first disconnect the AC and DC power supplies of the inverter.

**Warning!**

The inverter can not be operated when it is running.

**Warning!**

Risk of electric shock!

Strictly follow relevant safety specifications for product installation and testing. During installation, operation or maintenance, please read carefully and follow the instructions and precautions on the inverter or user manual. If the operation is incorrect, it may cause personal and property losses. Please keep the user manual properly after use.

This inverter can only use the accessories sold and recommended by our company, otherwise it may cause fire, electric shock or casualties. Without the authorization of our company, you may not open the inverter cover or replace the inverter parts, otherwise the warranty promise of the inverter will be invalid.

The use and operation of the inverter must be carried out in accordance with the instructions in this manual, otherwise this protection will fail and the warranty of the inverter will also fail. During working, the inverter surface temperature may exceed 60°C, please make sure the inverter cools down before touching, and make sure children can not touch.

When exposed to sunlight, photovoltaic arrays generate dangerous high DC voltages. Please follow our instructions, otherwise it will be life-threatening.

All DC and AC power sources must be disconnected from the inverter for at least 5 minutes before any wiring or electrical operation is performed on the inverter to ensure complete isolation of the inverter and avoid electric shock.

A photovoltaic module used on the inverter must have a IEC61730A rating, and the total open circuit voltage of the photovoltaic string / array is lower than the maximum rated DC input voltage of the inverter. Any damage caused by photovoltaic over voltage is not covered by warranty.

Installation position should be away from wet environment and corrosive substances.

After the inverter and power grid cut off the PV power supply, there will be a certain amount of residual current in a short time, be cautious or it may lead to serious personal injury and even high risk of death. Use a multimeter (impedance at least 1 MΩ) to measure the voltage between the UDC and the UDC- to ensure that the inverter port is discharged below the safe voltage before starting operation (35VDC).

➤ Surge protection devices (SPDs) for PV installation



Warning!

Over-voltage protection with surge arresters should be provided when the PV power system is installed. The grid connected inverter is fitted with SPDs in both PV input side and MAINS side.

Direct or indirect lightning strikes can cause failures. Surge is the main cause of lightning damage to most devices. Surge voltage may occur at photovoltaic input or AC output, especially in remote mountain areas where long distance cable is supplied.

Please consult professionals before installing SPDs.

The external lightning protection device can reduce the influence of direct lightning strike, and the lightning protection device can release surge current to the earth.

If the building installed with external light protection device is far away from the inverter location, in order to protect the inverter from electrical and mechanical damage, the inverter should also install an external lightning protection equipment.

In order to protect DC system, two-stage surge protection equipment is needed between DC cable of inverter and photovoltaic equipment module.

In order to protect the AC system, the level 2 surge protection equipment should be installed at the AC output, located between the inverter and the grid. Installation requirements must comply with IEC61643-21 standard.

All DC cables shall be installed in a distance as short as possible, and the positive and negative cables of the same input need to be bundled together to avoid causing loops in the system. Minimum distance installation and binding requirements also apply to auxiliary grounding and shielding grounding conductors.

➤ Anti-Islanding Effect

The islanding effect means that when the power grid is cut off, the grid-connected power generation system fails to detect the power outage and still supplies power to the power grid. This is very dangerous for the maintenance personnel and the power grid on the transmission line.

The inverter's use active frequency offset method to prevent islanding effect.

➤ PE Connection and Leakage Current

- All inverter's incorporate a certified internal Residual Current Monitoring (RCM) in order to protect against possible electrocution and fire hazard in case of a malfunction in the PV array, cables or inverter.

There are 2 trip thresholds for the RCM as required for certification (IEC 62109-2:2011).

The default value for electrocution protection is 30mA, and for slow rising current is 300mA.

- If an external RCD is required by local regulations, it is recommended to choose a Type-A RCD with the rating residual current of 300 mA.

	Warning! High leakage Current! Earth connection essential before connecting supply.
---	---

- A faulty ground connection can result in equipment failure, personal and death injuries, and electromagnetic interference.
- Ensure correct according to grounding to IEC62109 and conductor diameter according to STANDARD specification.
- Do not connect the grounding end of the equipment in series to prevent multi-point grounding.
- Electrical appliances must be installed in accordance with the wiring rules of each country.

For United Kingdom

- The installation that connects the equipment to the supply terminals shall comply with the requirements of BS 7671.
- Electrical installation of PV system shall comply with requirements of BS 7671 and IEC 60364-7-712.
- All protective devices cannot be changed.
- User shall ensure that equipment is so installed, designed and operated to maintain at all times compliance with the requirements of ESQCR22(1)(a).

➤ Battery Safety Instructions



The inverter should pair with high voltage battery, for the specific parameters such as battery type, nominal voltage and nominal capacity etc., please refer to section 3.3.

Please refer to the matching battery specification for details.





1.3.2 Explanation of Symbols







This section gives an explanation of all the symbols shown on the inverter and on the type label.

• Symbols on the Inverter

Symbols	Explanation
	Operating Display
	Battery status
	An error has occurred, please inform your installer immediately

• Symbols on the Type Label

Symbols	Explanation
	CE mark. The inverter complies with the requirements of the applicable CE guidelines.
	TUV certified.
	RCM remark.
	UKCA mark. The inverter complies with the requirements of the applicable UKCA guidelines.
	UKNI mark. The inverter complies with the requirements of the applicable UKNI guidelines.

	Beware of hot surface. The inverter can become hot during operation. Avoid contact during operation.
	Danger of high voltages. Danger to life due to high voltages in the inverter!
	Danger. Risk of electric shock!
	Observe enclosed documentation.
	The inverter can not be disposed together with the household waste. Disposal information can be found in the enclosed documentation.
	Do not operate this inverter until it is isolated from battery, mains and on-site PV generation suppliers.
	Danger to life due to high voltage. There is residual voltage existing in the inverter after powering off, which needs 5 min to discharge. Wait 5 min before you open the upper lid or the DC lid.

1.3.3 EC Directives

This chapter describes the requirements of the European low voltage regulations, including safety instructions and system licensing conditions, the user must comply with these regulations when installing, operating, and maintaining the inverter, otherwise it will cause personal injury or death, and the inverter will cause damage.

Please read the manual carefully when operating the inverter .If you do not understand "danger", "warning", "caution" and the description in the manual, please contact the manufacturer or service agent before installing and operating the inverter.

Grid-connected inverter comply with low voltage directive (LVD) 2014/35/EU and Electromagnetic compatibility directive (EMC) 2014/30/EU.Detection of components is based on:
EN 62109-1:2010 ;
EN 62109-2:2011 ;
IEC 62109-1(ed.1) ;
IEC62109-2(ed.1) ;
EN 61000-6-3: 2007+A:2011 ;
EN 61000-6-1: 2007 ;
EN 61000-6-2: 2005 ;

For installation in photovoltaic module system, it is necessary to make sure that the whole system complies with the requirements of EC(2014/35/EU, 2014/30/EU, etc.) before starting the module (i.e. to start the operation).The assembly shall be installed in accordance with the statutory wiring rules .Install and configure the system in accordance with safety rules, including the use of specified wiring methods. The installation of the system can only be done by professional assemblers who are familiar with safety requirements and EMC. The assembler shall ensure that the system complies with the relevant national laws.

The individual subassembly of the system shall be interconnected by means of the wiring methods outlined in national/international such as the national electric code (NFPA) No. 70 or VDE regulation 0107.

2 Introduction

2.1 Basic Features

This high-quality inverter can convert solar energy into alternating current and store energy into batteries. The inverter can be used to optimize self-consumption, stored in batteries for future use or fed into the public grid. The way it works depends on user preferences. It can provide emergency power during power outages.

2.2 Electrical Block Diagram of The System

The inverter has two wiring schemes, one is for M series inverter connected to X3-Matebox, and the other is for D series inverter.

There are different ways of wiring in different countries, one is to connect N line with PE line, the other is to separate the line from the PE line wiring, see below;

Diagram A: N line and PE line separate wiring, D series inverter; (For most countries)

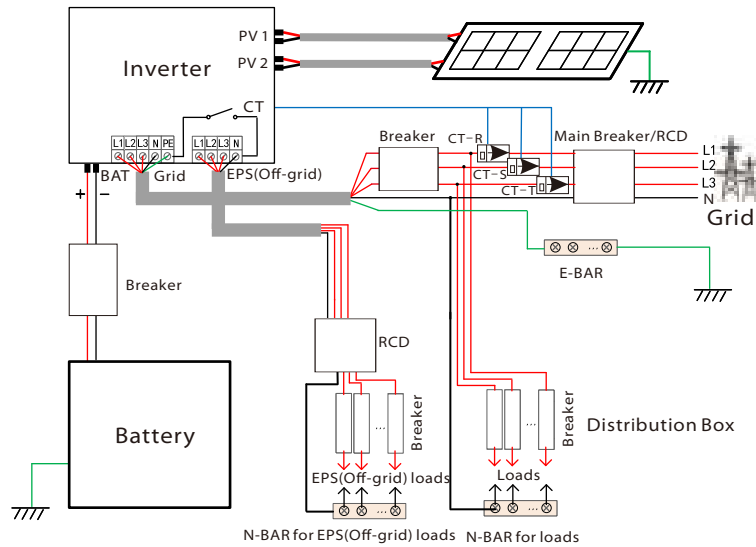

Diagram B: N line and PE line separate wiring, M series inverter; (For most countries)

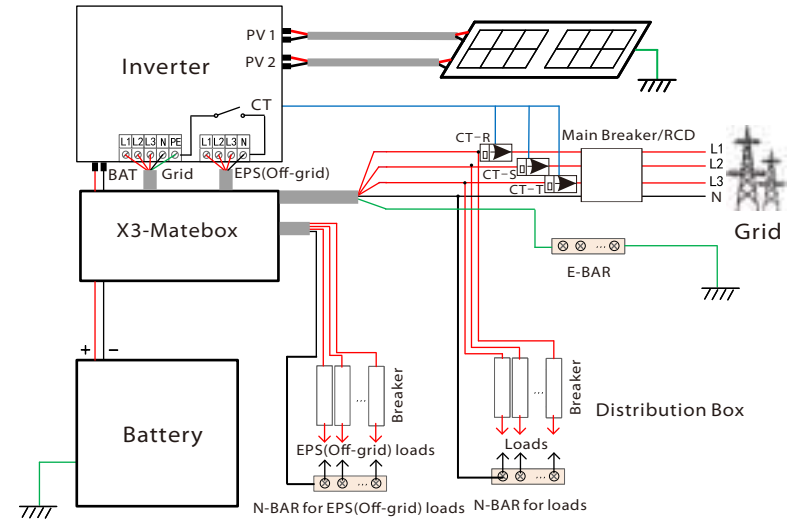

Diagram C: N line and PE line together, D series inverter; (Applicable to Australia)

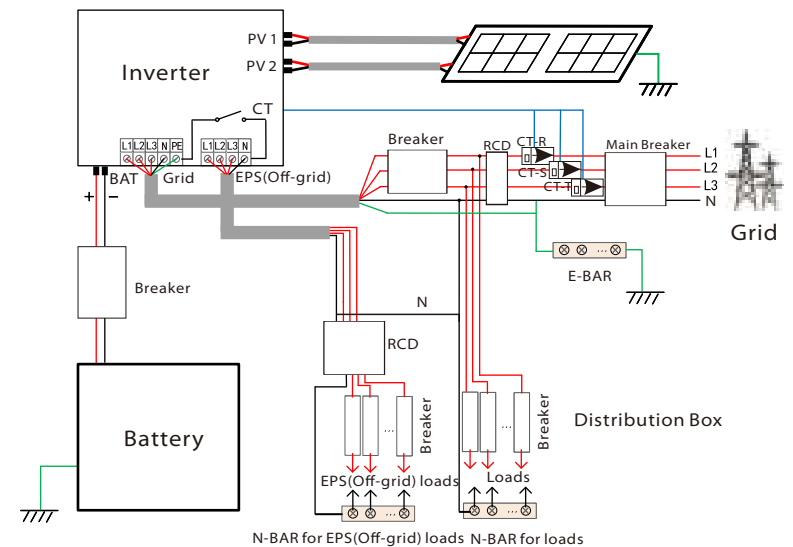
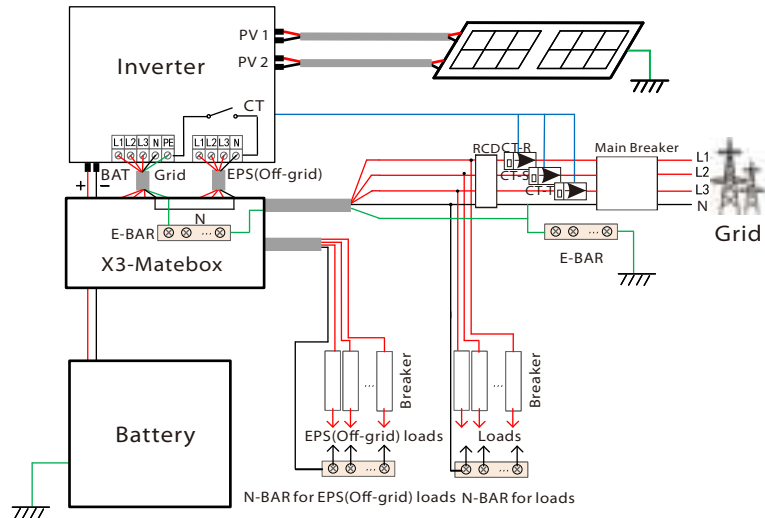

Diagram D: N line and PE line together, M series inverter;
(Applicable to Australia)



Note!
The RCD on the figure represents a leakage protection device with a circuit breaker function.

- When power cuts suddenly, the inverter connects the N line of EPS(Off-grid) load with the ground through relay, providing a fixed zero potential for EPS(Off-grid) load and ensuring the safety of electricity use by users.
- Please control the inverter load and make sure it is "output value" in "within" EPS(Off-grid) mode, otherwise the inverter will stop and alarm overload fault".
- Please confirm with the grid operator whether there are special regulations for grid connection.

2.3 Work Modes

The inverter can be based on different needs, there are a variety of models.

Self Use

The self-use mode is suitable for areas with low feed-in subsidies and high electricity prices.

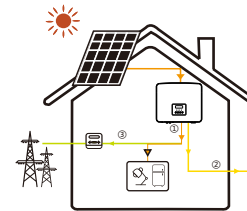

① When the power of PV is sufficient
Active Charging or Discharge time period: PV will power the battery. When the battery is fully charged, PV will power the load, and then sell the surplus power to the grid. (The inverter will limit the output if Feed-in limit or zero feed-in is needed)
(PV > Battery charge, PV → Battery → Load → Grid)

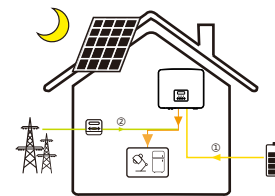

② When the power of PV is insufficient
Active Charging time period: PV will power the battery and the remaining power will be taken from the grid when PV is not enough. PV and grid power will charge the battery until it reaches the set value. And then PV will power the load and the remaining power will be taken from the grid when PV is not enough. The battery will not discharge at this time.
(PV < Battery charge, PV + Grid → Battery)
Active Discharge time period: PV+BAT will power the loads together. If the power is still not enough, the remaining power will be taken from the grid.
(PV < Load, PV + Battery + Grid → Load)

③ Without PV power
Active Charging time period: The grid supplies the loads and also can charge the battery;
(PV=0, Grid → Load + Battery)
Active Discharge time period: The battery will power the home loads firstly. If the battery power is not enough, the remaining power will be taken from the grid. The inverter will enter into the standby state.
(PV=0, Battery+Grid → Load)

Battery min SOC can be set: 10%-100%;
Charge battery to min SOC can be set: 10%-100%.

Feed-in priority

The Feed-in priority mode is suitable for areas with high feed-in subsidies, but has feed-in power limitation.

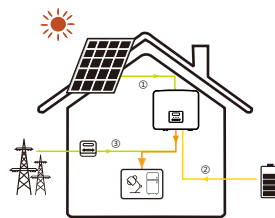

① When the power of PV is sufficient
Active Charging time period: PV power the battery to the set value, and then power the load, and sell the surplus power to the grid.
If the local grid company limits the grid-connected power of the inverter, the excess energy continues to charge the battery.
(PV > Battery, PV → Battery → Load → Grid → Battery)

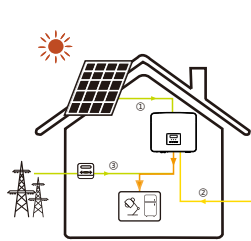

Feed-in priority

Active Discharge time period: PV will power the loads firstly, and surplus power will feed-in to the grid.
($PV > Load$, $PV \rightarrow Load \rightarrow Grid$)

② When the power of PV is insufficient
Active Charging time period: PV will power the battery and the remaining power will be taken from the grid when PV is not enough. PV and grid power will charge the battery until it reaches the set value. And then PV will power the load and the remaining power will be taken from the grid when PV is not enough. The battery will not discharge.
($PV < Battery\ charge$, $PV + Grid \rightarrow Battery$)
Discharge time period: PV+BAT will power the loads together.
If the power is still not enough, the remaining power will be taken from the grid.
($PV < Load$, $PV + Battery + Grid \rightarrow Load$)

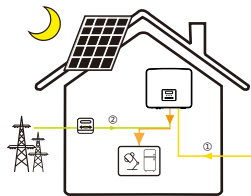

③ Without PV power
Active Charging time period: The grid will power the home loads and also charge the battery;
($PV = 0$, $Grid \rightarrow Load + Battery$)

Active Discharge time period: The battery will power the home loads firstly. If the battery power is not enough, the remaining power will be taken from the grid. The inverter will enter into the standby state.
($PV = 0$, $Battery + Grid \rightarrow Load$)

Battery min SOC can be set: 10%-100%;
Charge battery to min SOC can be set: 10%-100%.

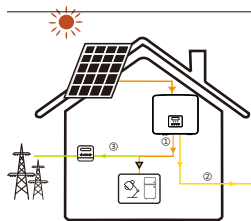

Backup mode

The back-up mode is suitable for areas with frequent power outages. Same working logic with "Self-use" mode. This mode will maintain the battery capacity at a relatively high level. (Users' setting) to ensure that the emergency loads can be used when the grid is off. Customers no need to worry about the battery capacity.

Battery min SOC can be set: 30%-100%.
Charge battery to min SOC can be set: 30%-100%.

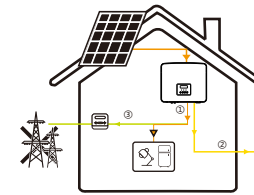
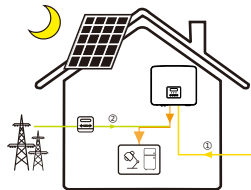

EPS(Off-grid) mode

In case of power failure, the system will power EPS loads through PV and battery.
(Battery must be installed for this mode)

① When the power of PV is sufficient
PV will power the loads firstly, and surplus power will charge to the battery.
($PV > Load$, $PV \rightarrow Load \rightarrow Battery$)
② When the power of PV is insufficient
The remaining power will be taken from the battery.
($PV < Load$, $PV \rightarrow Load \rightarrow Battery$)
③ Without PV power
The battery will power the emergency loads until the battery reached the min SOC, then the inverter will enter into the idle mode.
($PV = 0$, $Battery \rightarrow Load$)
EPS(off-grid) SOC-min condition is adjustable within the range of 10%-25%.

Note: in the case of grid connection, all working modes work normally when the battery SOC > 5%. When the Min SOC of the system - the actual SOC of the battery > 5%, PV or Grid will force the battery to charge to Min SOC + 1%, and then return to the normal working mode set by the user.

Note: when the actual SOC of the battery is \leq Min SOC, if the mains power is lost, the inverter will not enter the EPS (Off-grid) mode. The inverter is in EPS Waiting state, at which time the PV will charge the battery. When the battery capacity reaches 31%, the machine will automatically enter EPS (Off-grid) mode.

2.4 Dimension

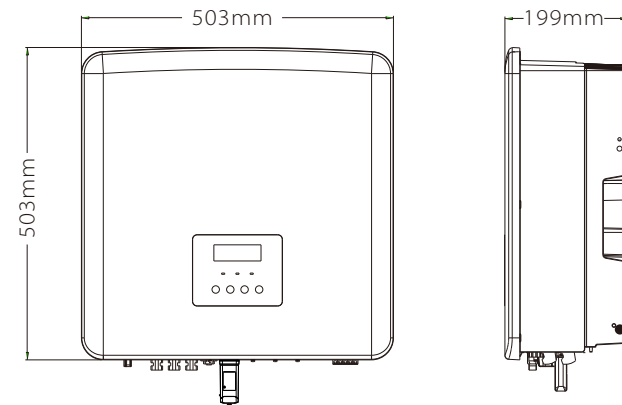

2.5 Terminals of Inverter

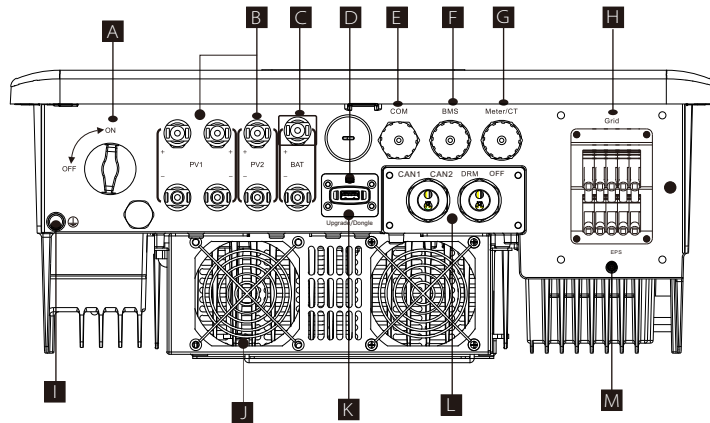

Object	Description
A	DC switch
B	PV connection port
C	Battery connection port
D	USB port for upgrading
E	COM port
F	Battery communication
G	Meter/CT Port
H	Grid connection port
I	Ground connection port
J	Fans(only for X3-Hybrid-12.0-D/M and X3-Hybrid-15.0-D/M)
K	External monitoring connection port
L	CAN1 and CAN2 are for parallel communication / OFF is for external shutdown/ DRM Port(only for Australia)
M	EPS(Off-grid) Output(main load connection port)



Warning!

Qualified electrician required for the installation.

3 Technical Data

3.1 DC Input(apply to version D/M)

Model	X3-Hybrid-5.0	X3-Hybrid-6.0	X3-Hybrid-8.0	X3-Hybrid-10.0	X3-Hybrid-12.0	X3-Hybrid-15.0
Max. recommended DC power [W]	A:4000/B:4000	A:5000/B:5000	A:8500/B:5000	A:10500/B:6000	A:11000/B:7000	A:11000/B:7000
Max. DC voltage [V]	1000	1000	1000	1000	1000	1000
Nominal DC operating voltage [V]	630	630	630	630	630	630
Operating voltage typical [V]	180-950	180-950	180-950	180-950	180-950	180-950
Max. input current [A]	16/16	16/16	26/16	26/16	26/16	26/16
Max. short circuit current [A]	20/20	20/20	30/20	30/20	30/20	30/20
Start output voltage [V]	200	200	200	200	200	200
No. of MPP trackers	2	2	2	2	2	2
Strings per MPP tracker	A:1/B:1	A:1/B:1	A:2/B:1	A:2/B:1	A:2/B:1	A:2/B:1

3.2 AC Output/Input(apply to version D/M)

Model	X3-Hybrid-5.0	X3-Hybrid-6.0	X3-Hybrid-8.0	X3-Hybrid-10.0	X3-Hybrid-12.0	X3-Hybrid-15.0
AC Output						
Nominal AC power [W]	5000	6000	8000	10000	12000	15000(PEA 14000)
Max. apparent AC power [VA]	5500	6600	8800	11000	13200	15000
Rated AC voltage [V]	415/240; 400/230; 380/220					
Rated grid frequency [Hz]	50/60					
Max. AC current [A]	8.1	9.7	12.9	16.1	19.3	24.1
Displacement power factor	1 (0.8 leading...0.8 lagging)					
Total harmonic distortion(THDi)	< 3%					
AC Input						
Rated AC power [W]	10000	12000	16000	20000	20000	20000
Rated grid voltage(range) [V]	415/240; 400/230; 380/220					
Rated grid frequency [Hz]	50/60					
Max. AC current [A]	16.1	19.3	25.8	32.0	32.0	32.0

3.3 Battery(apply to version D/M)

Model	X3-Hybrid-5.0	X3-Hybrid-6.0	X3-Hybrid-8.0	X3-Hybrid-10.0	X3-Hybrid-12.0	X3-Hybrid-15.0
Battery type	Lithium batteries					
Battery Full Voltage [V]	180-800					
Maximum charge/discharge flow [A]	30A					
Communication interface	CAN/RS485					
Reverse connection protection	Yes					

3.4 Efficiency, Safety and Protection(apply to version D/M)

Model	X3-Hybrid-5.0	X3-Hybrid-6.0	X3-Hybrid-8.0	X3-Hybrid-10.0	X3-Hybrid-12.0	X3-Hybrid-15.0
MPPT efficiency	99.9%	99.9%	99.9%	99.9%	99.9%	99.9%
European efficiency	97.7%	97.7%	97.7%	97.7%	97.7%	97.7%
Maximum efficiency	98.2%	98.2%	98.2%	98.2%	98.2%	98.2%
Max. battery charge efficiency (PV to BAT)(@ full load)	98.5%	98.5%	98.5%	98.5%	98.5%	98.5%
Max. battery discharge efficiency (BAT to AC)(@ full load)	97.5%	97.5%	97.5%	97.5%	97.5%	97.5%
Security & Protection						
DC SPD Protection	Integrated					
AC SPD Protection	Integrated					
Over/under voltage protection	YES					
Grid protection	YES					
DC injection monitoring	YES					
Back feed current monitoring	YES					
Residual current detection	YES					
Anti-islanding protection	YES					
Over load protection	YES					
Over heat protection	YES					
Array insulation resistance detection	YES					

3.5 EPS(Off-grid) Output(apply to version D/M)

Model	X3-Hybrid-5.0	X3-Hybrid-6.0	X3-Hybrid-8.0	X3-Hybrid-10.0	X3-Hybrid-12.0	X3-Hybrid-15.0
EPS(Off-grid) rated power [VA]	5000	6000	8000	10000	12000	15000
EPS(Off-grid) rated voltage [V]	400V/230VAC					
Frequency [Hz]	50/60					
EPS(Off-grid) rated current [A]	7.2	8.7	11.6	14.5	17.5	21.8
EPS(Off-grid) Peak Power [VA]	7500, 60s	9000, 60S	12000, 60S	15000, 60S	15000, 60S	16500, 60S
Switching time [s]	<10ms					
Total harmonic distortion (THDv)	<3 %					

3.6 Generic Data(apply to version D/M)

Model	X3-Hybrid-5.0	X3-Hybrid-6.0	X3-Hybrid-8.0	X3-Hybrid-10.0	X3-Hybrid-12.0	X3-Hybrid-15.0
Dimensions (W/H/D)[mm]	503*503*199					
Dimensions of Packing (W/H/D)[mm]	560*625*322					
Net weight [kg]	30	30	30	30	30	30
Gross weight * [kg]	34	34	34	34	34	34
Heat dissipation treatment	Natural Cooling				Smart Cooling	
Noise emission(typical) [dB]	<40					
Storage temperature range [°C]	-40~+70					
Operating temperature range[°C]	-35~+60 (derating at 45)					
Humidity [%]	0%~100%					
Altitude [m]	<3000					
Ingress Protection	IP65					
Protective Class	I					
Cold standby consumption	<5W					
Over voltage category	III(MAINS), II(PV, Battery)					
Pollution Degree	III					
Installation mode	Wall mounted					
Inverter Topology	Non-isolated					
Communication interface	Meter/ CT, external control RS485, Pocket series, DRM, USB					

* The specific gross weight is subject to the actual situation of the whole machine.

4 Installation

4.1 Check for Transport Damage

Ensure that the inverter is in good condition via transportation. If there is any visible damage such as cracks, please contact the dealer immediately.

4.2 Packing List

Open the package and check the materials and accessories according to the following list.

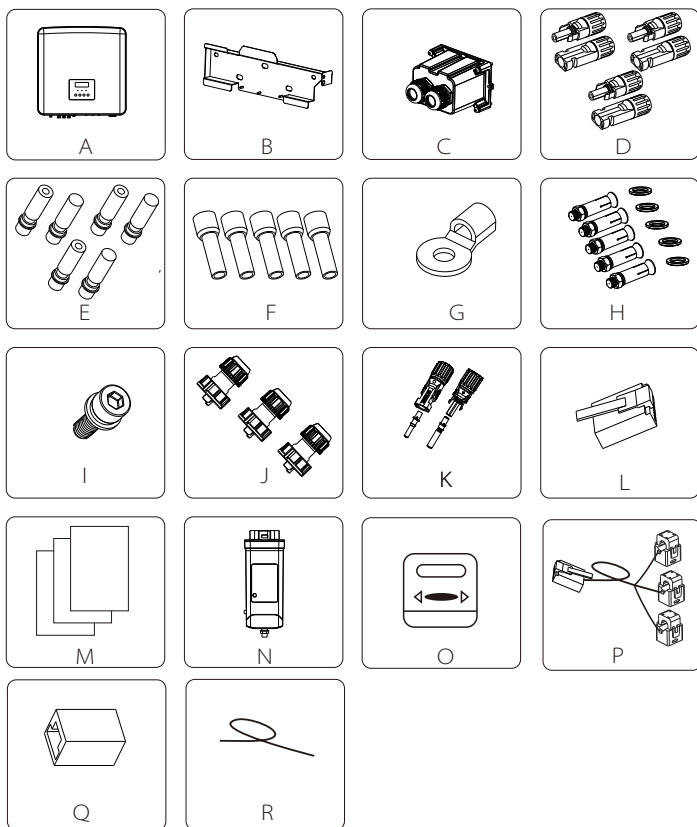

Number	Quantity	Description (for M series)
A	1	the inverter
B	1	Wall-mount Bracket
H	5	(Expansion bolt, Gasket, Self-tapping bolt)
I	1	M5 inner hexagon bolt
J	3	Communication line RJ 45 adapter (COM/Meter/BMS)
L	6	RJ 45 terminals
M		Documentations
N	1	Pocket WiFi
O	1	Meter (optional)
P	1	RJ 45 Terminal adapter
R	1	Ground cable

Number	Quantity	Description (for D series)
A	1	the inverter
B	1	Wall-mount Bracket
C	1	Waterproof shield
D	6	PV terminal (positive*2 or 3, negative*2 or 3)
E	6	PV pin angle (positive*2 or 3, negative*2 or 3)
F	12	6 mm ² European terminals
G	1	OT terminal(inverter grounding)
H	5	(Expansion bolt, Gasket, Self-tapping bolt)
I	1	M5 inner hexagon bolt
J	3	Communication line RJ 45 adapter (COM/Meter/BMS)
K	2	Battery connection terminals (positive*1, negative*1)
L	6	RJ 45 terminals
M		Documentations
N	1	Pocket WiFi
O	1	Meter (optional)
P	1	CT
Q	1	RJ 45 Terminal adapter

Note:

" L " The inverter in Australia needs to be connected to DRM, which is 1 more communication line RJ 45 adapter than that in other countries.

The number of "D" and "E" are different for different power sections. For 5-6kW inverters, the number of positive and negative PV terminal and PV pin angle is 2, 2, 2 and 2 respectively. For 8- 15kW inverters, the number of positive and negative PV terminal and PV pin angle is 3, 3, 3 and 3 respectively.

4.3 Installation Precautions

The protection level of the inverter is IP 65, so that the inverter can be installed outdoors.

Check the installation environment and pay attention to the following conditions when installing:

- Do not expose to strong light.
- Do not touch flammable building materials.
- Do not approach flammable and explosive gases or liquids (e.g. where chemicals are stored).
- Do not touch cold air directly.
- Do not approach TV antenna or cable.
- Do not place in areas above 3000 meters above sea level.
- Do not install in precipitation or high humidity, which may cause corrosion or damage Internal devices.

If the inverter is installed in a narrow area, be sure to reserve appropriate space for heat dissipation.

The ambient temperature of the installation site is -35°C~60°C.

The maximum angle range of wall tilt $\pm 5^\circ$.



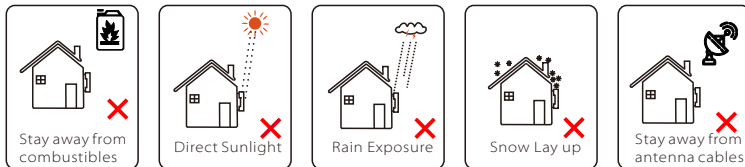
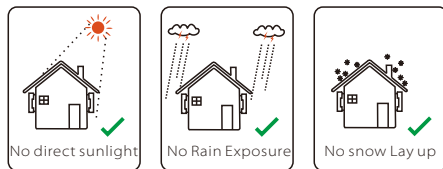



Avoid direct sunlight, rain and snow weather.



4.4 Tool preparation

Tool equipment					
Type	Name	Image	Name	Image	
Machine Installation Tools	Hammer drill	Bit $\Phi 8$ 	Multimeter	DC Voltage Range $\geq 1100VDC$ 	
	Torque screwdriver	Crosshead M5 	Socket wrench set (Hexagon)		
	OT terminals press clamp	0.5mm ² ~6mm ² 	Diagonal pliers		
	Utility knife		Multifunction terminal crimping tool (RJ45)		
	wire stripper		Marker		
	Rubber hammer		Tape measure		
	Crimping Tool		Hexagon keys		
	Euro terminal crimping tool		Spirit level		
	Individual Protection Tools	Dustproof Cover		Protective glasses	

Tool equipment				
Type	Name	Image	Name	Image
Individual Protection Tool	Safety gloves		Safety shoes	

Type	Name	Image	Requirement
Equipment Preparation	Breaker		Grid port and EPS(Off-grid) port wiring section (4.5.2)
Cable Preparation	PV end wire		Dedicated PV wire, line number #4 mm ² withstand voltage 1000V, temperature resistance 105°C fire resistance grade VW-1
	EPS (Off-grid) end wire		Five-core cable
	Grid end wire		Five-core cable
	Communication lines		Twisted pair with shield
	Battery Cable		Conventional wire
	PE Cable		Conventional wire

4.5 Installation Site Conditions

4.5.1 Installation Carrier Requirements

Do not install the inverter near flammable materials. Please install the inverter on a solid object that can withstand the weight requirements of the inverter and energy storage system. Please be careful not to install the inverter in the plasterboard wall or similar to the residential places with poor sound insulation, so as not to work with noise and interfere with the residents' life in the morning.

4.5.2 Installation Requirements

Install the inverter at a maximum back tilt of 5 degrees, the inverter can not be tilted forward, inverted, excessive back tilted or side tilted.

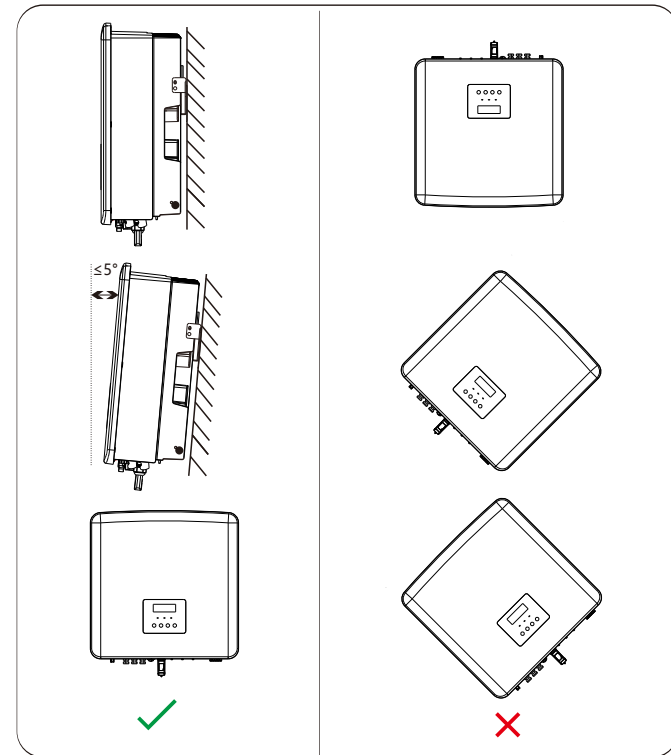

4.5.3 Installation Space Requirements

Reserve enough space when installing inverter (at least 300mm) for heat dissipation.

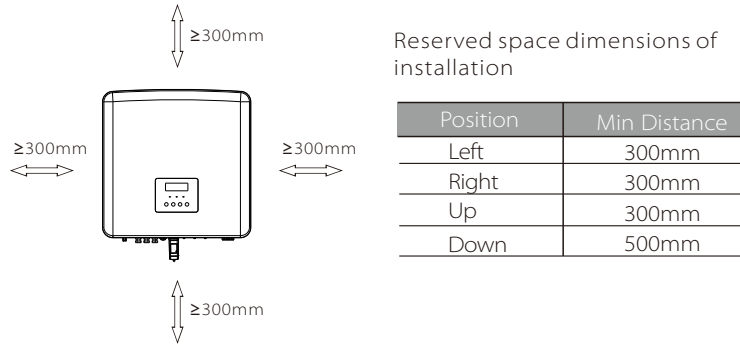

For multi-inverter installation scenarios, the inline installation method is recommended; when the space is insufficient, the recommended method of installation in the form of "products"; it is not recommended to install multiple inverters in stacks. If you choose stack installation, please refer to the installation separation distance below.

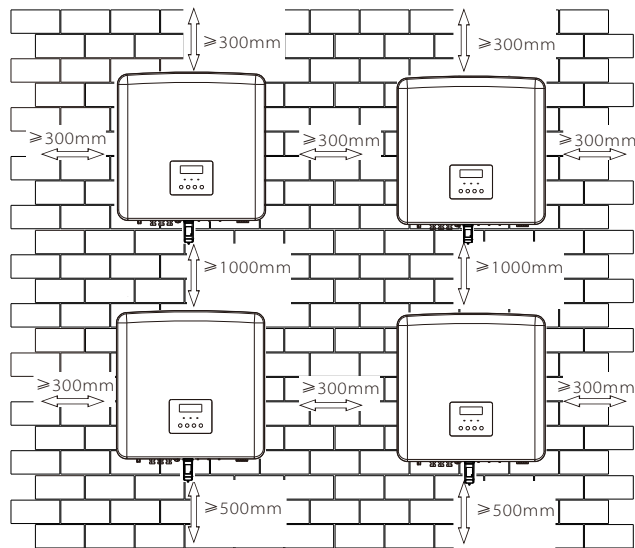

4.6 Mounting

➤ Preparation

Please prepare the following tools before installation.



Installation tools: screwdriver, wrench, Φ8 drill, rubber hammer, socket wrench set and Hexagon keys.

➤ Step 1: Fix the wall bracket to the wall

First find the expansion screw and the wall bracket in the accessory bag, as shown below:

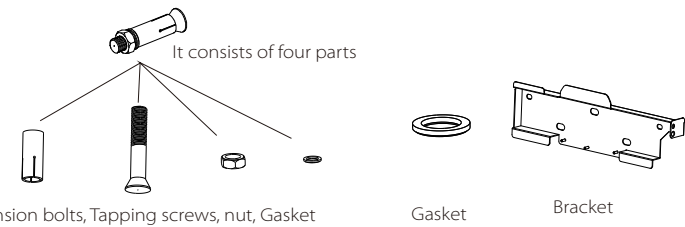

- Use a spirit level and a marker to mark drilling holes of the bracket on the wall.
- Drill holes at marked spots with depth of 65 mm.

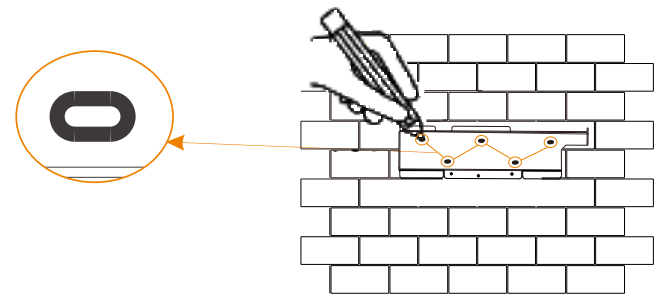

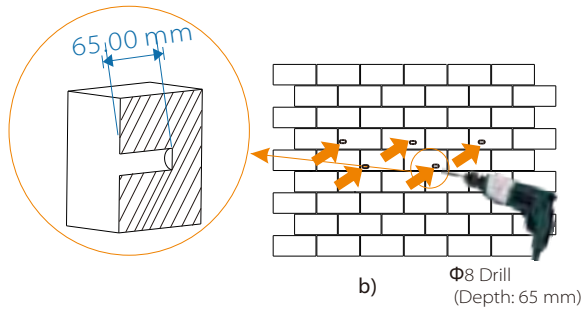

➤ Step 2: hang the inverter on the bracket

- c) Insert expansion bolt into the hole, use rubber hammer to knock the expansion screw bolt into the wall;
- d) The bracket is aligned with the screw uses the inner hexagonal wrench to screw the tapping screw until the expansion bolt "bang" is heard.

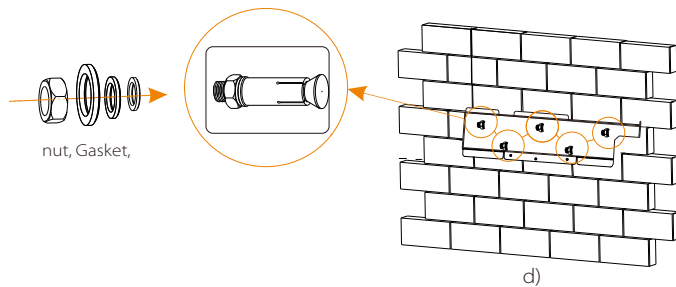
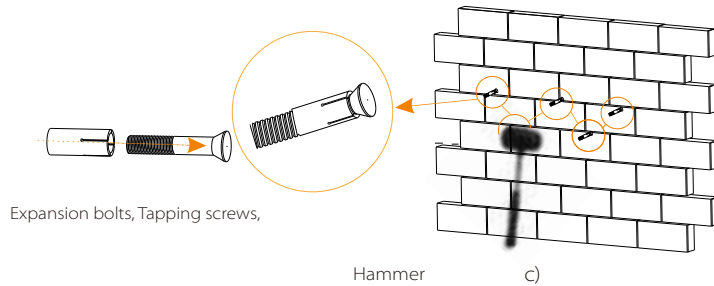

➤ Step 3: Tighten the inverter and bracket

- e) Hang the buckle on the inverter to the corresponding position of the backplane;
- f) Use the inner hexagonal wrench to tighten the inner hexagonal screw on the right side of the inverter.

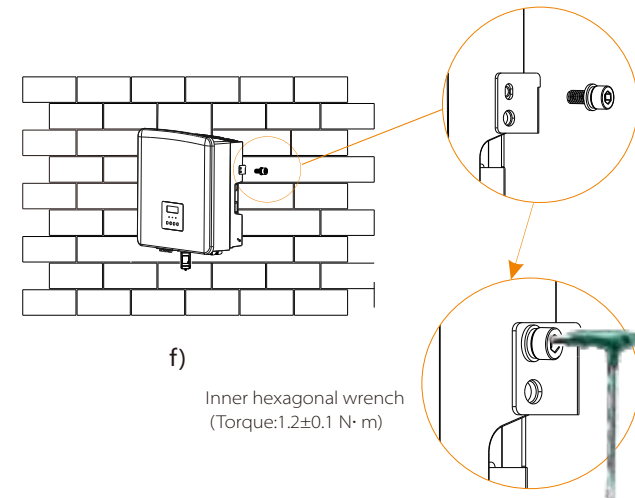
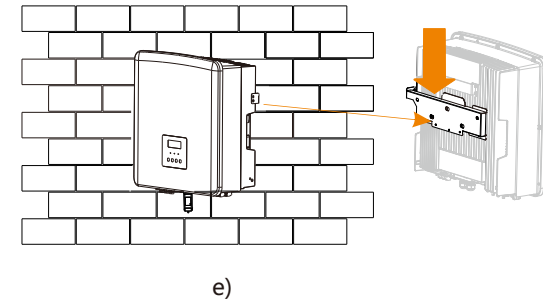

5 Electrical Connections

5.1 PV Connection

The inverter have two PV inputs. Please select photovoltaic modules with good performance and quality assurance. The open circuit voltage of the module array should be less than the maximum PV input voltage specified by the inverter, and the working voltage should be within the MPPT voltage range.

Table 1: Maximum input voltage limit(apply to version D/M)

Model	X3-Hybrid-5.0	X3-Hybrid-6.0	X3-Hybrid-8.0	X3-Hybrid-10.0	X3-Hybrid-12.0	X3-Hybrid-15.0
Max. DC input voltage	1000V					



Warning!

The voltage of photovoltaic modules is very high, and is dangerous voltage. When wiring, please follow the safe electricity regulations.



Note!

Please do not make PV positive or negative ground!



Note!

The following PV module requirements need to be applied to each input range:

1. Same model
2. Same quantity
3. The same array
4. The same angle

Notice!

The series inverters support the following PV module connection modes.

1. Method 1: Multi

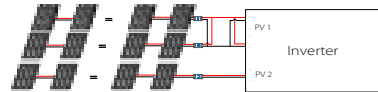

2. Method 2: Common

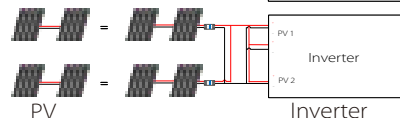
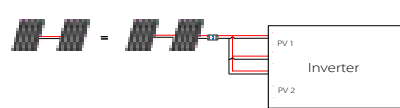

➤ **Connection step**

The PV port wiring of the M series inverter has been completed. For specific installation details, please refer to the X3-Matebox Quick Installation Guide, the D series needs to be wired according to the following steps.

Step 1. Turn off the DC switch, connect the PV module, prepare a 4 mm² PV cable, and find the PV (+) terminal and PV (-) terminal in the package.

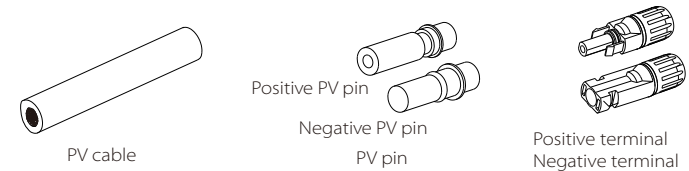

Step 2. Use a wire stripper to strip the 7mm insulation layer of the wire end.

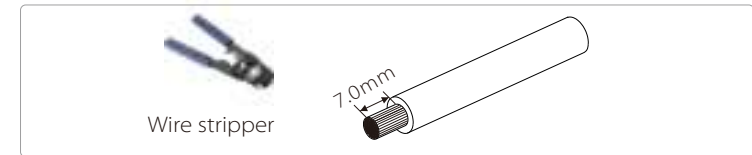

Step 3. Tighten the cable with the insulation layer stripped and insert it into the metal terminal (see Figure 1), make sure all wires are inserted into the metal terminal (see Figure 2).

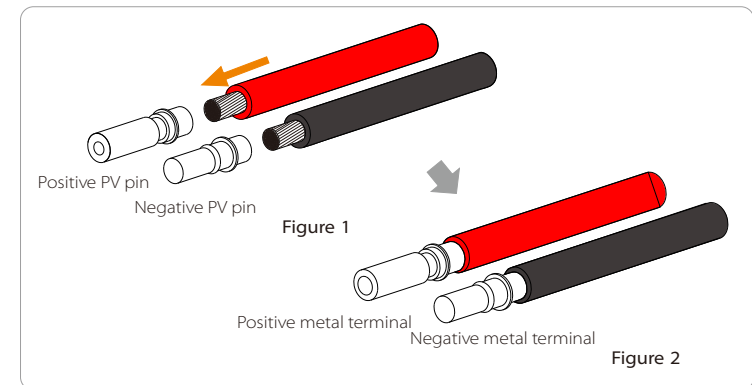

Step 4. Tighten the PV pin needle and the wiring harness to make the connection tight without looseness.

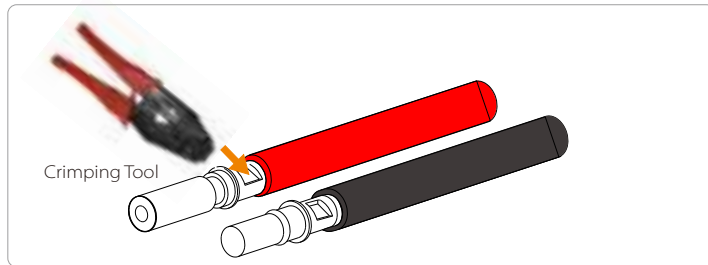

Step 5. The PV joint is divided into 2 parts - the plug and the fastening head. Insert the cable through the fastening head and the opposite plug. Note that the red and black lines correspond to different of plugs. Finally, force the cable pair into the plug, will a "click" sound, which indicates that the connection is complete.

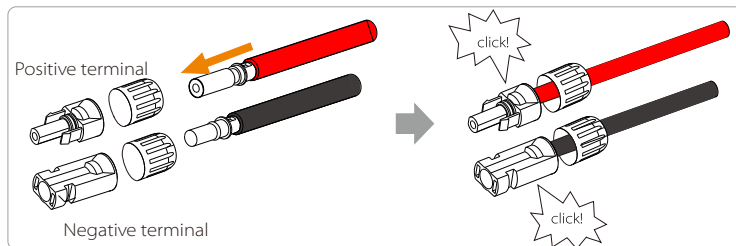

Step 6. Tighten the fastening head and into insert the corresponding positive and negative (PV-/PV+) ports of the inverter.

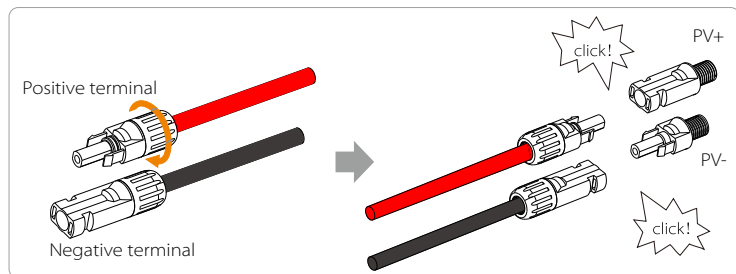

The following is the location of the inverter's positive and negative (PV-/PV+) ports.

Note: Before inserting the PV terminal, please turn on the switch of the PV module and use a multimeter to measure the positive and negative poles of the PV terminal port to prevent reverse connection.

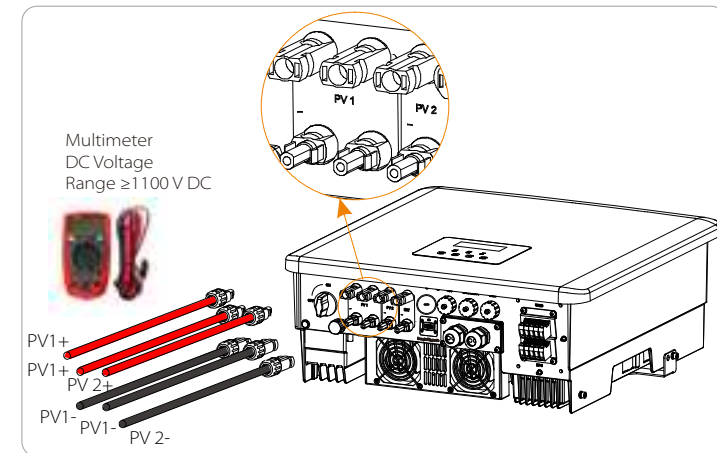

Schematic diagram of the inverter PV connected.

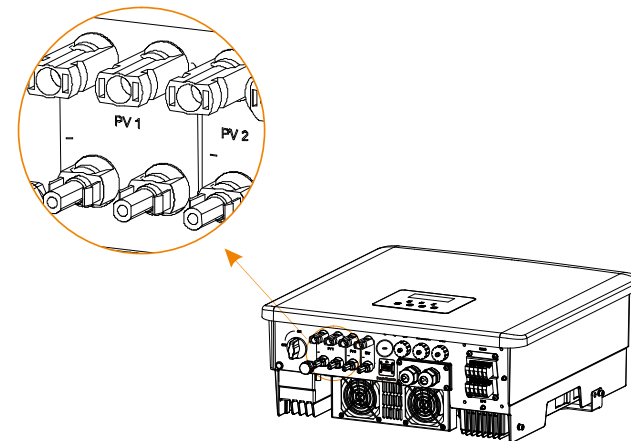

5.2 Grid Port and EPS(Off-grid) Output Connection

The inverter is three-phase inverter. Suitable for rated voltage 380/400/415V, frequency 50/60Hz. Other technical requests should comply with the requirement of the local public grid.

➤ Grid port connection

Grid Cable and Micro-breaker recommended
(apply to version D/M)

Model	X3-Hybrid-5.0	X3-Hybrid-6.0	X3-Hybrid-8.0	X3-Hybrid-10.0	X3-Hybrid-12.0	X3-Hybrid-15.0
Cable (copper)	4~6mm ²	4~6mm ²	4~6mm ²	5~6mm ²	5~6mm ²	5~6mm ²
Micro-Breaker	20A	20A	32A	40A	40A	40A

EPS(Off-grid) Cable and Micro-breaker recommended
(apply to version D/M)

Model	X3-Hybrid-5.0	X3-Hybrid-6.0	X3-Hybrid-8.0	X3-Hybrid-10.0	X3-Hybrid-12.0	X3-Hybrid-15.0
Cable (copper)	4~6mm ²	4~6mm ²	4~6mm ²	4~6mm ²	4~6mm ²	4~6mm ²
Micro-Breaker	16A	16A	20A	25A	32A	32A

The load should not be directly connected to the inverter.

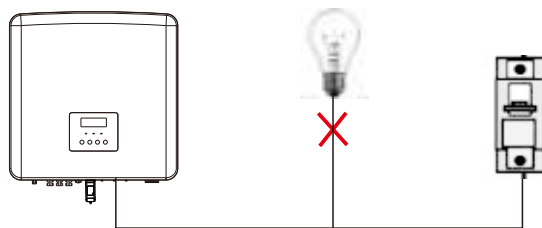

Figure: Wrong connection of load and inverter

5.3 EPS(Off-grid) Block Diagram

The inverter has an EPS(Off-grid) function. When the grid is connected, the inverter outputs go through the Grid port, and when the grid is disconnected, the inverter outputs go through the EPS(Off-grid) port. The EPS(Off-grid) function can be connected to part of the load. Please refer to the following diagram for the wiring.

If you want to save installation time, you will need an accessory. If you need a solution, please contact our sales staff.

➤ EPS(Off-grid) wiring diagram

Diagram A: N line and PE line separate wiring, D series inverters;
(For most countries)

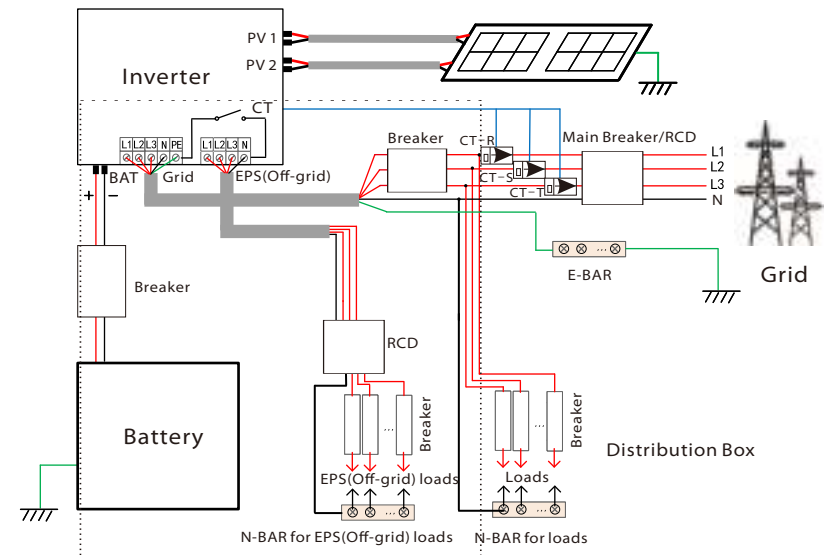

Diagram B: N line and PE line separate wiring, M series inverters;
(For most countries)

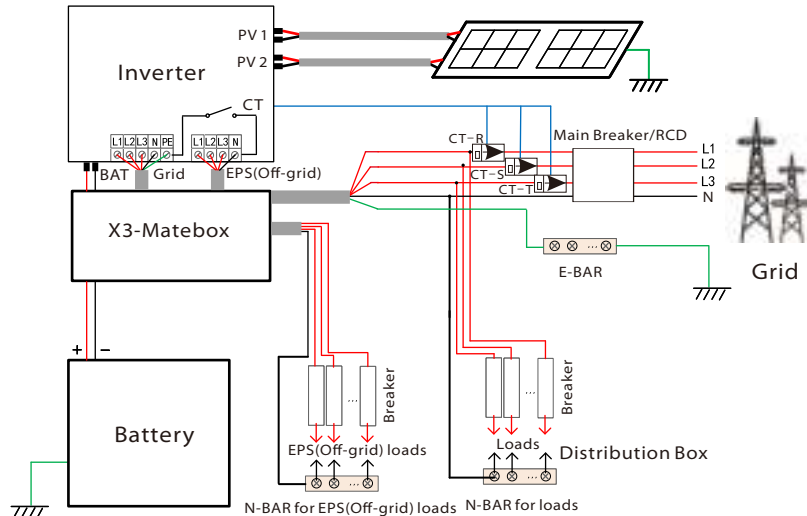

Diagram C: N line and PE line together, D series inverters;
(Applicable to Australia)

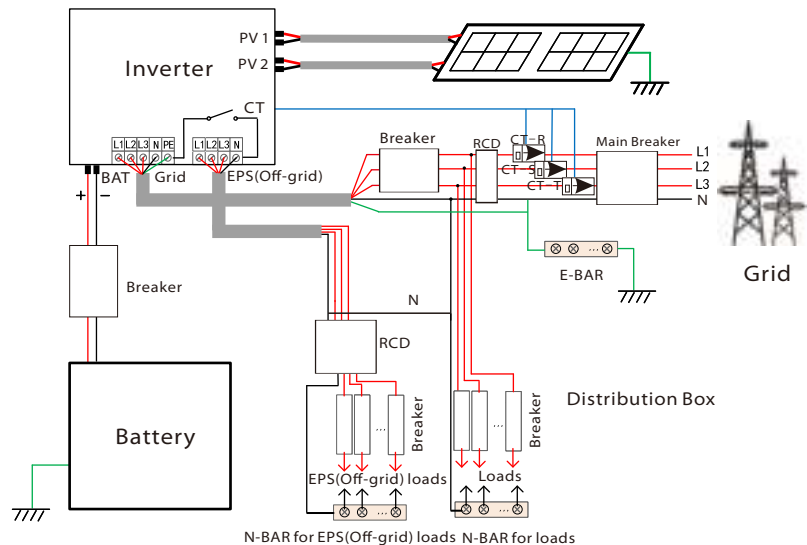
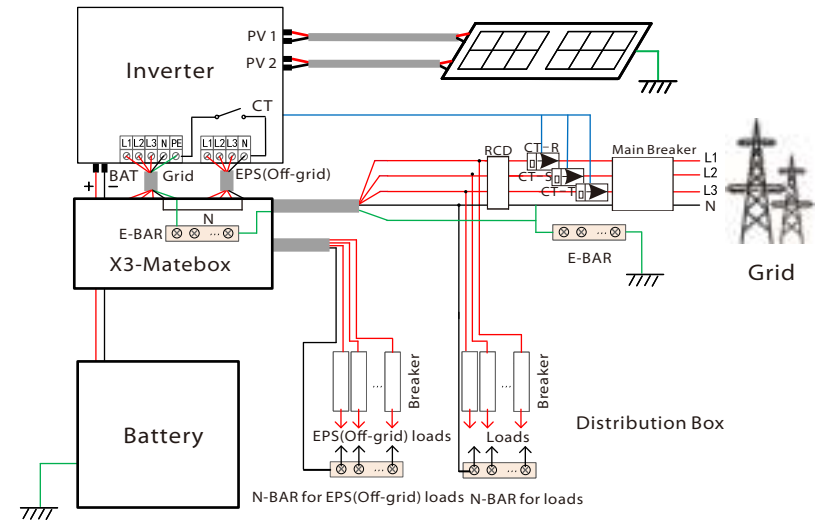



Diagram D: N line and PE line together, all load connection EPS(Off-grid)
scheme;(Applicable to Australia)



X3-Matebox is a convenient wiring accessory. Please refer to X3-Matebox for details. If you need to purchase X3-Matebox, please contact us.

 The RCD on the figure represents a leakage protection device with a circuit breaker function. To use X3-Matebox's **Diagram B** and **Diagram D**, you need to set "X3-Matebox" to "Enable" in "Settings"; The Australian customer must shorten the N lines of the Grid and the EPS(Off-grid) in the X3-Matebox. If your local wiring method does not follow the above operation guide, especially the neutral wire, ground wire, RCD wire, please contact our company before operation.

➤ EPS(Off-grid) load requirements

Warning!
 Ensure that the EPS(Off-grid) load rated power is within the EPS(Off-grid) rated output power range, otherwise, the inverter will report an "overload" warning.







When "overload" occurs, adjust the load power to make sure it is within the EPS(Off-grid) rated output power range, and the inverter will automatically return to normal.

For non-linear loads, ensure that the inrush current power is within the EPS(Off-grid) rated output power range. When the configuration current is less than the maximum DC input current, the capacity and voltage of lithium and lead acid will decrease linearly.

The following table shows some common loads for your reference.

Note: Please check with the manufacturer for high-power inductive loads.

Content	Power		Common equipment	Instance		
	Start	Rated		Equipment	Start	Rated
Resistive load	X 1	X 1	 Incandescent lamp	 100W Incandescent lamp	100VA (W)	100VA (W)
Inductive load	X 3~5	X 2	 Fan  Fridge	 150W Fridge	450-750VA (W)	300VA (W)

Note: The EPS load of the inverter does not support a half-wave load, and the half-wave load cannot be used here.

➤ Grid and EPS(Off-grid) connection steps

- Connection requirements

Note: Check the grid voltage and compare the voltage range (see technical data).
 Disconnect the circuit board from all power sources to prevent electric shock.

The Grid and the EPS(Off-grid) ports of the M series inverter have been connected, for specific installation details, please refer to the X3-Matebox Quick Installation Guide. And the D series needs to be wired according to the following steps.

Step 1. Prepare a Grid cable (five-core wire) and an EPS(Off-grid) cable (four-core wire), and then find the European terminal and waterproof cover in the accessory bag.

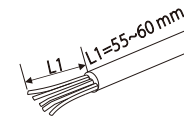

6 mm² Grid(Five-Core Cable)

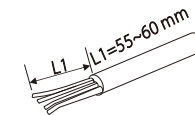

6 mm² EPS(Off-grid)(Four-Core Cable)



6 mm² Euro Terminal*10

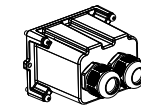

Waterproof cover

Step 2. First remove the waterproof housing plug, and then the Grid and EPS(Off-grid) cables through the waterproof housing corresponding to the Grid and EPS(Off-grid) ports.

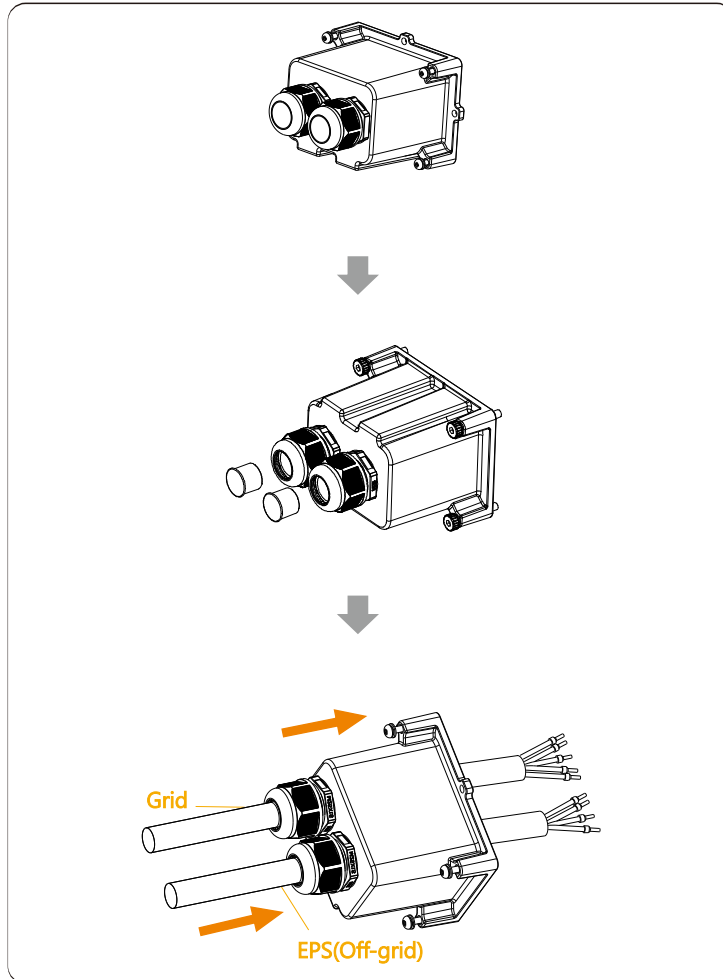

Step 3. Remove the 12mm insulation layer at the end of the wire. Insert the European-style terminals respectively, and make sure that the stripped ends are inserted into the European-style terminal, and finally use crimping pliers to press tightly.

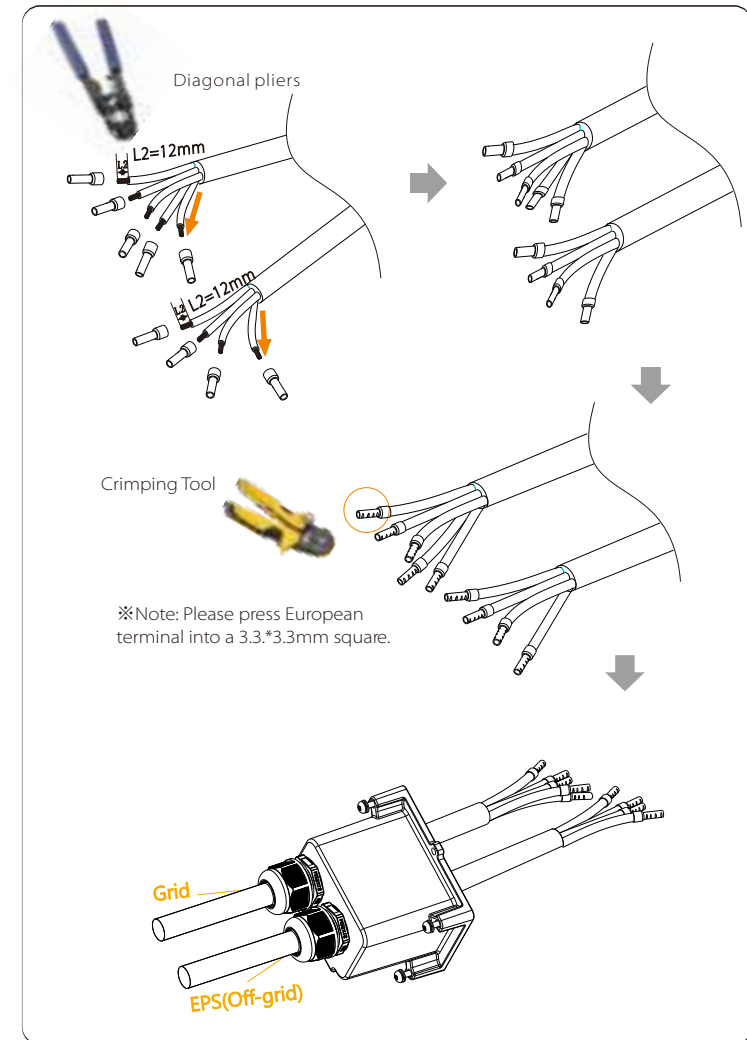

Step 4. Find the location of the AC interface on the inverter, insert the crimped terminals into the UW10 terminals L1, L2, L3, N, and PE according to the wire sequence, and use a flat-blade screwdriver to tighten the screws. (Torque: $1.5 \pm 0.1 \text{ N}\cdot\text{m}$)

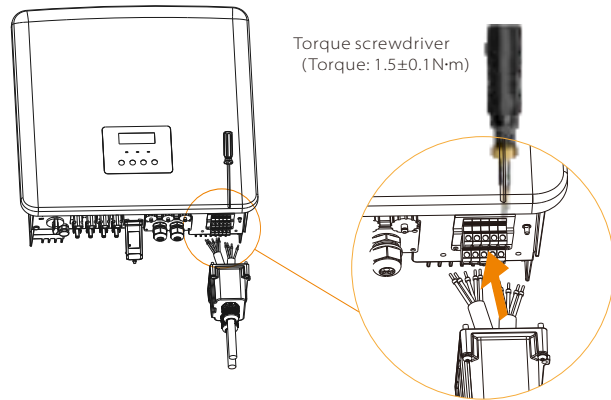

Step 5. Install the AC waterproof cover, and tighten the screws on the four sides of the waterproof cover with an Hexagon keys. (Torque: $0.4 \pm 0.1 \text{ N}\cdot\text{m}$)

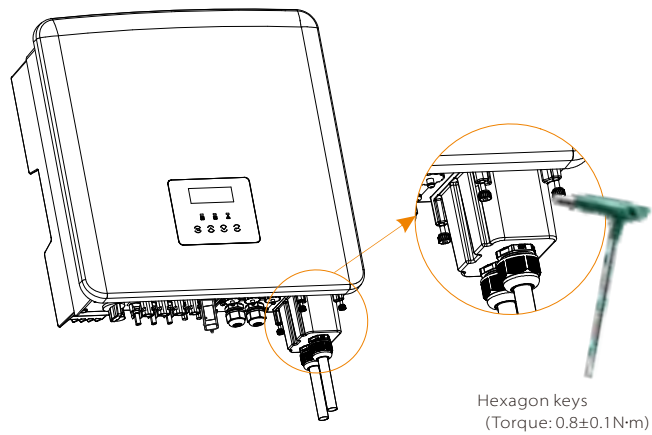

Step 6. Tighten the waterproof fastening head.

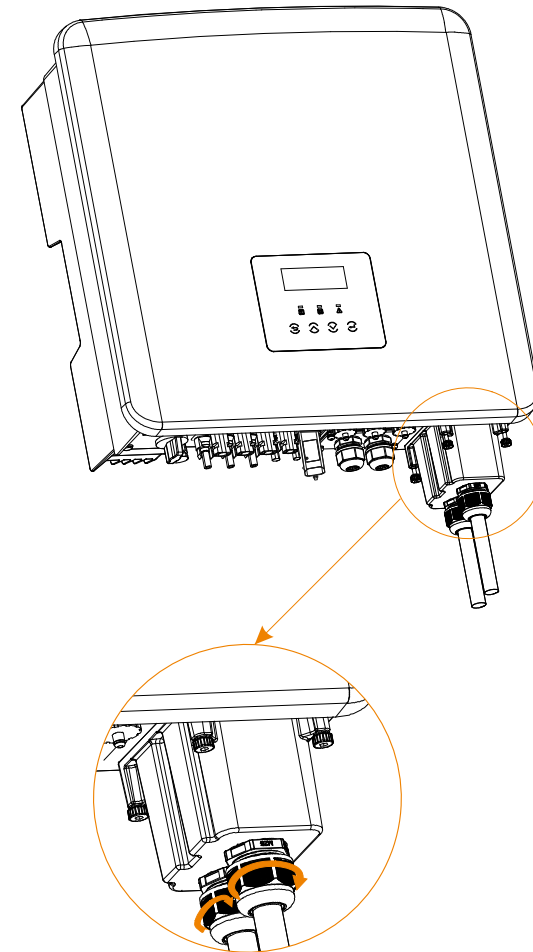

5.4 Battery Connection

➤ Connection requirements

The inverter charge and discharge system can be equipped with high voltage lithium battery .

Please note that the maximum voltage of the battery should not exceed 650V, battery communication should be compatible with the inverter.

➤ Battery Breaker

Before connecting the battery, a non-polar DC MCB must be installed to ensure safety.

Before maintenance, the inverter need to be safely disconnected.

Model	X3-Hybrid-5.0	X3-Hybrid-6.0	X3-Hybrid-8.0	X3-Hybrid-10.0	X3-Hybrid-12.0	X3-Hybrid-15.0
Voltage	Nominal voltage of DC breaker should be larger than maximum voltage of battery.					
Current[A]	32A					

Note: The above situation applies to the D/M version.

➤ Battery connection diagram

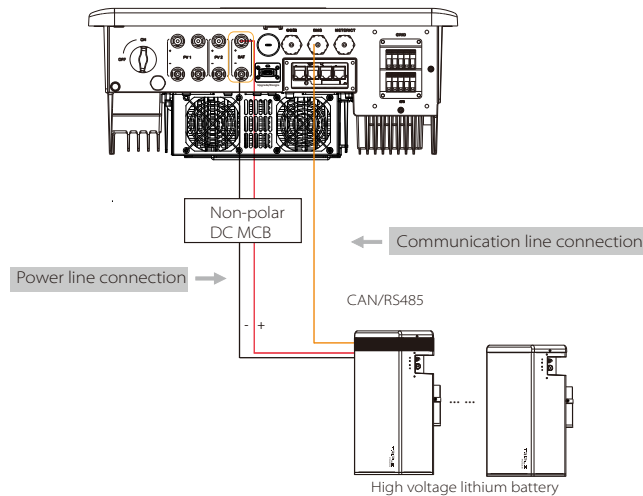

Note:

When using our battery, it is recommended to use the number of battery control (T-BAT-5.8) is 1, the number of battery modules (HV11550) is 1-3; the number of battery control (Mc0600) is 1, the number of battery modules (HV10230) is 2-4.

➤ Battery connection steps

Battery port connection line of the M series inverter is on the X3-Matebox, for specific installation details, please refer to the X3-Matebox Quick Installation Guide It is necessary to wire the D series according to the following steps.

Step 1. Turn off the DC switch, connect the BAT module, prepare a 6 mm² BAT cable, and find the BAT (+) terminal and BAT (-) terminal in the package.

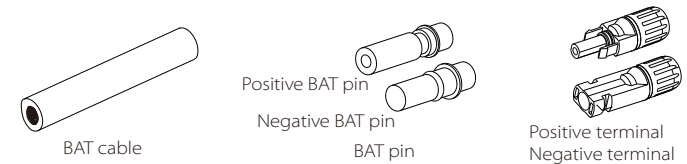

Step 2. Use a wire stripper to strip the 7mm insulation layer of the wire end.

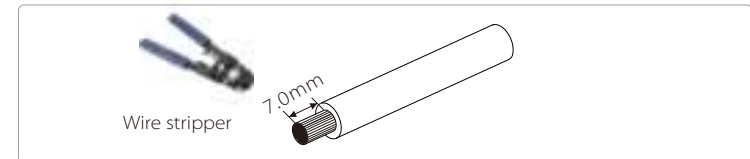

Step 3. Tighten the cable with the insulation layer stripped and insert it into the metal terminal (see Figure 1), make sure all wires are inserted into the metal terminal (see Figure 2).

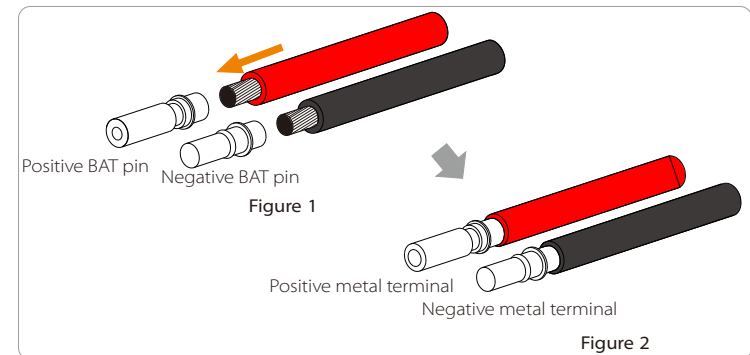

Step 4. Tighten the BAT pin needle and the wiring harness to make the connection tight without looseness.

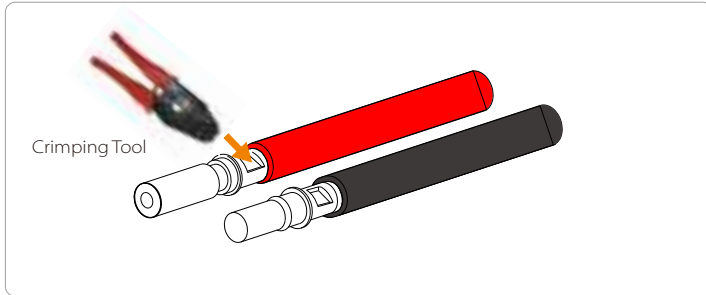

Step 5. The BAT joint is divided into 2 parts - the plug and the fastening head. Insert the cable through the fastening head and the opposite plug. Note that the red and black lines correspond to different of plugs. Finally, force the cable pair into the plug, will a "click" sound ,which indicates that the connection is complete.

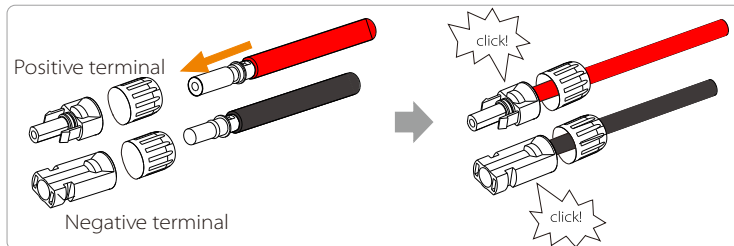

Step 6. Tighten the fastening head and into insert the corresponding positive and negative (BAT-/BAT+) ports of the inverter.

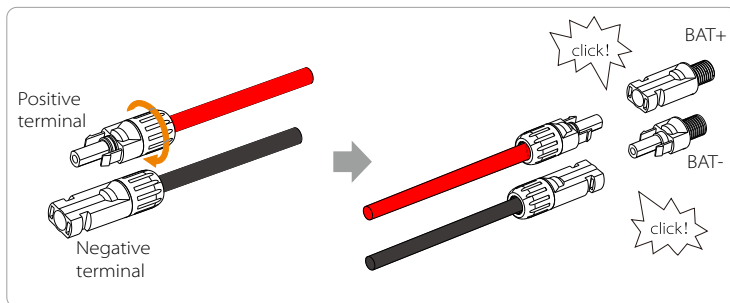

Step 7. Insert the battery power lines into the corresponding BAT port (+), (-) of the inverter.

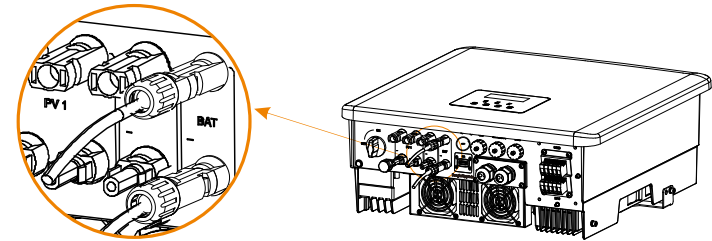

Note: BAT port, not PV port!

Note: The positive and negative wires of the battery are not allowed to be reversed!

➤ Communication connection

BMS port definition

The communication interface between the inverter and the battery uses the waterproof connector with RJ 45.

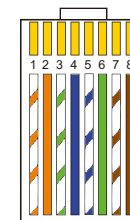
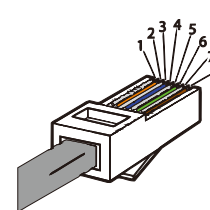

- 1) White with orange stripes
- 2) Orange
- 3) White with green stripes
- 4) Blue
- 5) White with blue stripes
- 6) Green
- 7) White with brown stripes
- 8) Brown

1	2	3	4	5	6	7	8
X	X	X	BMS_CANH	BMS_CANL	X	BMS_485A	BMS_485B

Note!
 After the BMS communication between the battery and the inverter is finished, the battery will work normally.

5.5 Communication Connection

5.5.1 Introduction to DRM communication (AS4777 regulatory requirements)

DRM requirements:

Mode	Requirement
DRM0	Operation disconnect device
DRM1	Do not consume power
DRM2	Do not consume more than 50% of rated power
DRM3	Do not consume more than 75% of rated power AND Source reactive power if capable
DRM4	Increase power consumption (subject to constraints from other active DRM's)
DRM5	Do not generate power
DRM6	Do not generate more than 50% of rated power
DRM7	Do not generate more than 75% of rated power AND Sink reactive power if capable
DRM8	Increase power generation (subject to constraints from other active DRM's)

1	2	3	4	5	6	7	8
DRM1/5	DRM2/6	DRM3/7	DRM4/8	+3.3V	DRM0	GND	GND

Note!

Currently only PIN6 (DRM0) and PIN1 (DRM1/5) are functional, other PIN functions are under development.

5.5.2 Introduction to meter/CT Communication

The inverter should work with an electric meter or current sensor (CT for short) to monitor household electricity usage. The electricity meter or CT can transmit the relevant electricity data to the inverter or platform, which is convenient for users to read at anytime.

Users can choose to use electric meters or CTs according to their needs.

Please note that the meter/CT brand required by our company must be used.

Note!

The meter or CT must be connected to the inverter, otherwise the inverter will shut down and alarm "meter failure" alarm. Smart meters must be authorized by our company, third party or other companies, Unauthorized meter may be incompatible with the inverter.

Our company will not be responsible for the impact caused by the use of other appliances.

➤ Electric meter connection diagram

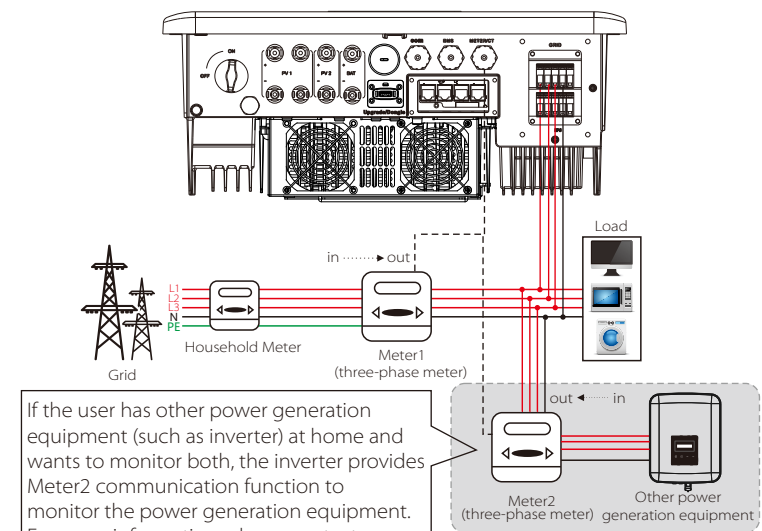

If the user has other power generation equipment (such as inverter) at home and wants to monitor both, the inverter provides Meter2 communication function to monitor the power generation equipment. For more information, please contact us.

Note: If you want to connect the meter, please ground the GND terminal of the Meter1.

➤ **CT Connection**

The current sensor measures the current on the live wire between the inverter and the public grid.

• **CT connection diagram**

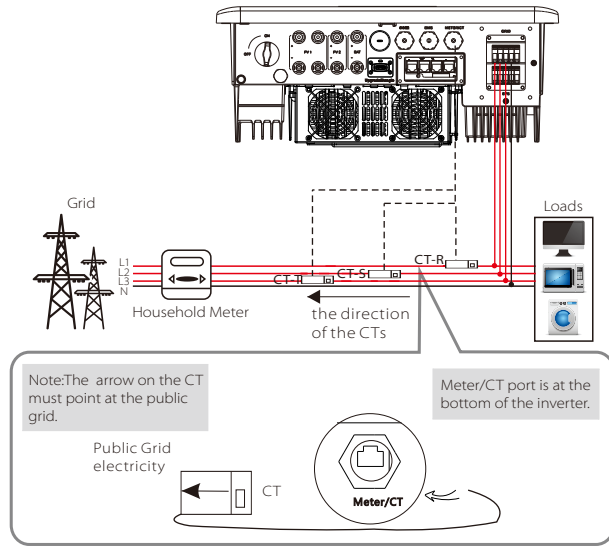

• **LCD settings**

To select CT, you need to enter Use setting, then enter CT/Meter Setting.

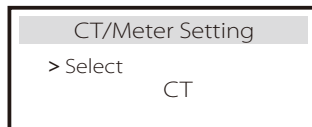

• **Note for CT connection:**



Note!

- Do not place the CT on the N wire or ground wire.
- Do not put CT on the N line and L line at the same time.
- Do not place the CT on the side where the arrow points to the inverter.
- Do not place the CT on non-insulated wires.
- The cable length between CT and inverter should not exceed 100 meters.
- After CT is connected, prevent the CT clip from falling off. It is recommended to wrap the CT clip around in circles with insulating tape.

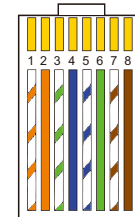

1	2	3	4	5	6	7	8
CT-R-1	CT-S-1	CT-T-1	485A	485B	CT-T-2	CT-S-2	CT-R-2

Note!

Only one of the Meter and CT connections can be selected. Meter cable goes to pin terminal 4 and 5; CT-R cable to PIN Terminal 1 and 8; CT-S cable to PIN Terminal 2 and 7; CT-T cable is connected to terminals 3 and 6.

5.5.3 Parallel Connection

The inverter provides the parallel connection function. Diagram 1 should make 10 inverters maximumly connected in one system and diagram 2 allows up to 3 inverters to be connected in one system. In these two systems, one inverter will be set as the "Master inverter" which will control every other inverters. Diagram 1 system needs to be equipped with an X3-EPS Parallel Box (G2), and communicate with the "Master Inverter", and all other slave inverters are connected to the "Master Inverter" in parallel via network cable.

➤ System Diagram

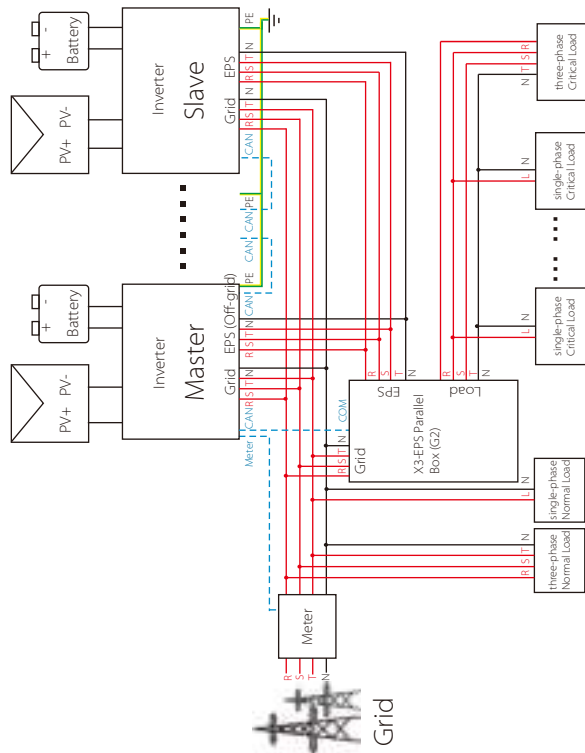

Diagram 1

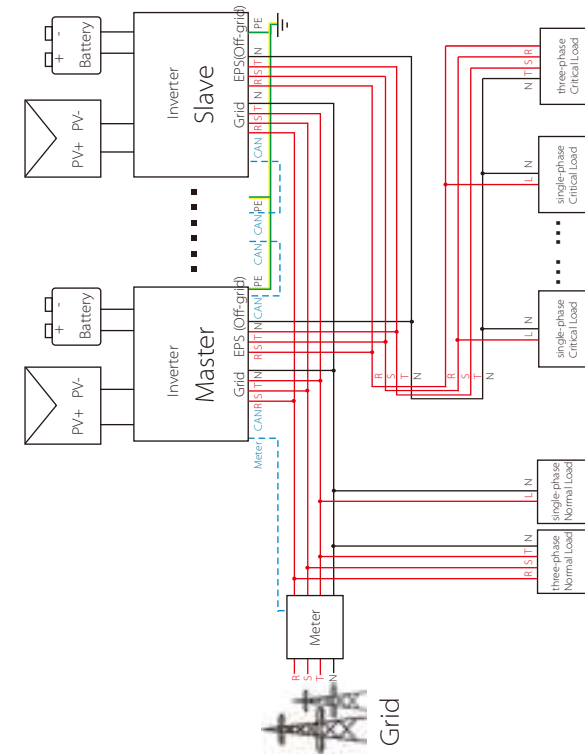



Diagram 2



Important Warning!

- The hybrid parallel system is extremely complex and a large amount cables need to be connected, therefore it is strongly required that **every cable must be connected according to correct line sequence(R-R, S-S, T-T, N-N)**, otherwise any small misoperation may cause the system running failed.

➤ Work Modes in Parallel System

There are three work modes in parallel system, and your acknowledge of different inverter's work modes will help you understand parallel system better, therefore please read it carefully before operating.

Free mode	Only if no one inverter is set as a "Master", all inverters are in free mode in the system.
Master mode	When one inverter is set as a "Master", this inverter enters master mode. Master mode can be changed to free mode.
Slave mode	Once one inverter is set as a "Master", all other inverters will enter slave mode automatically. slave mode can not be changed from other modes by LCD setting.

➤ **Wiring Operation and LCD Setting**



Note: Before operation, please make sure that the inverter meets the following three conditions,
 1. The software version of all inverters is the same;
 2. The power range of all inverter models is the same;
 3. The type and quantity of batteries connected to all inverters are the same;
 Otherwise, this function cannot be used.



Note: There are two CAN ports on the inverter. The CAN port of the inverter set as the "host" is connected. The CAN port on the left on the bottom frame of the inverter must be connected to the COM port of the X3-EPs Parallel Box (G2), and the CAN port on the right is connected "Slave".

For diagram 1

Step1: Connect all inverters' communication together by connecting network cables between CAN ports.
 - Use standard network cables for CAN-CAN connection and insert one end of the cable into CAN1 of the master inverter and the other end into the COM port of X3-EPs Parallel Box (G2).
 - Insert one end of network cable into the first inverter's CAN2 port and the other end into the next inverter's CAN1 port and other inverters are connected in such way .
 - Insert one end of network cable into the meter, and the other end into the meter port the master inverter.

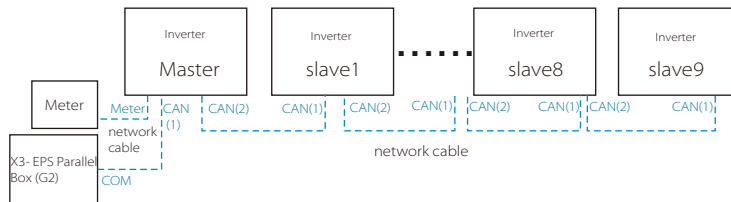

Note:A CT can be used in the parallel connection of the Hybrid series inverters only when the master inverter are with PV panels or only the meter can be used. In the parallel connection of the Fit series inverters, only the meter can be used.

For diagram 2

Step1: Connect all inverters' communication together by connecting network cables between CAN ports.
 - Use standard network cables for CAN-CAN connection.
 - Use network cable to connect master inverter CAN2 port and slave 1 inverter CAN1 port, and connect slave 1 inverter CAN2 port and slave2 inverter CAN1 port.
 - Use network cable to connect master inverter meter port and meter.

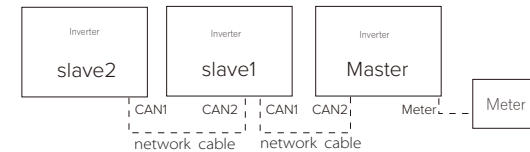

➤ **CAN PIN Definition**

	1	2	3	4	5	6	7	8
	485A	485B	VCC	CANH	CANL	GND	SYN1	SYN2

Step 2: Connect the power cable between X3- EPs Parallel Box (G2) and inverter (R/S/T/N/PE) in diagram 1.

-If the user purchased the X3-EPs Parallel Box (G2) product, please refer to the X3-EPs Parallel Box (G2) user manual for installation and connection.
 -If the user purchased the X3-EPs Parallel Box (G2) product, please refer to the X3-EPs Parallel Box (G2) user manual for installation and connection.

For example, the wiring diagram of the X3-EPs Parallel Box power line.

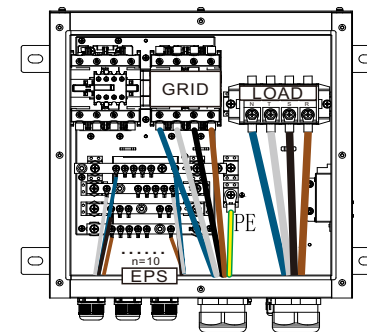

X3-EPs Parallel Box

Step 3: Turn on the power of the entire system, find the inverter connected to the meter, enter the setting page of the inverter LCD screen, click on the parallel settings, and select "master control"; then enter the "resistance switch" and set it to "ON";
 Finally, find the last slave in the parallel system and enter the setting page of the inverter LCD screen and set the "resistance switch" to "ON".

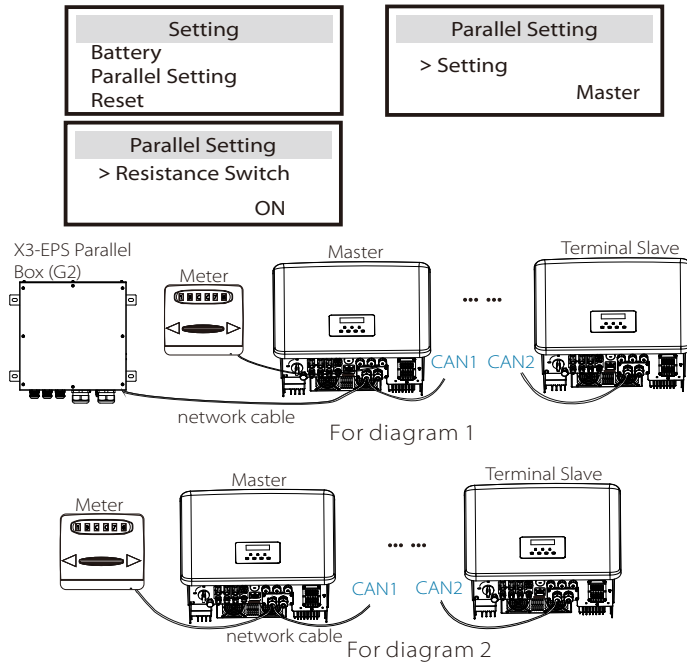

➤ **How to Remove parallel system**

If one inverter wants to exit from this parallel system, please do the steps as below:

- Step1: Enter setting page and click parallel setting, and choose "Free".
- Step2: Disconnect all the network cables on the CAN port.

Note!

- If a slave inverter is set to "Free" mode but not disconnect the network cable, this inverter will return to "slave" mode automatically.
- If a slave inverter is disconnected with other inverter but not be set to "Free" mode, this inverter will stop working and maintain "waiting" status.

➤ **LCD display**

Main display:

Once inverter enters parallel system, the "today yield" will be replaced by "Inverter Class", and parallel relevant fault has a higher priority than other faults and will be showed firstly on main display.

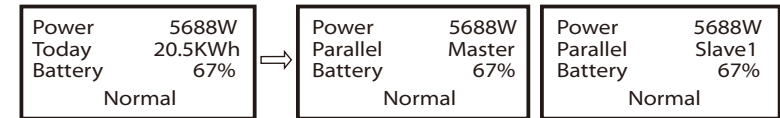

Status display:

User can obtain all the status data from master inverter. System power and individual slave inverter power can be obtain in status display of master inverter.

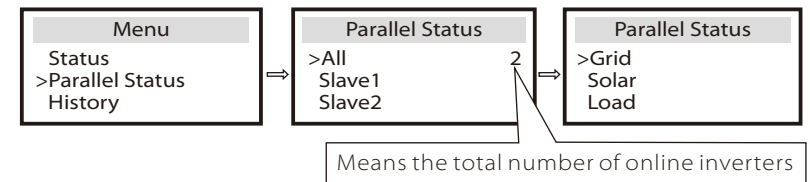

➤ **Parallel Control Function**

Master inverter has an absolute lead in the parallel system to control all slave inverter's energy management and dispatch control. Once master inverter has some error and stop working, all slave inverter will be stop simultaneously. But master inverter is independent of all slave inverter to work and will not be affected by slave inverter's fault.

Overall system will be running according to master inverter's setting parameters, and most setting parameters of slave inverter will be kept but not be cancelled.

Once slave inverter exit from system and be running as an independent unit, its all setting will be re-executed. The rest of this section covers several important parallel control functions, and the next page table shows which LCD options are controlled by master inverter and which can work independently.

Off mode setting:

Off mode can only be set by master inverter (long press ESC button on LCD).

Safety setting:

System safety protection is cancelled by master inverter's safety. slave inverter protection mechanism will only be triggered by master inverter's instructions.

Self-use setting:

If system is running as self-use mode, please note the Feedin Power Limit set of master inverter is for the overall system and the corresponding set of slave inverter is invalid.

Power Factor setting:

All sets about power factor are all for the overall system and the corresponding sets of slave inverter are invalid.

Remote control setting:

The remote demand instructions received by master inverter will be interpreted as the demand instructions to overall system.

5.5.4 COM Communication

COM communication interface is mainly provided for customization the second step of development use. The inverter supports the control of external equipment or external equipment control through communication.

For example, the inverter adjusts the working mode of the heat pump and so on.

➤ **Application occasion**

COM is a standard communication interface, through which the monitoring data of the inverter can be directly obtained. Also, external communication devices can be connected to carry out the secondary development of the inverter. For specific technical docking, please contact us.

External communication equipment controls the inverter:

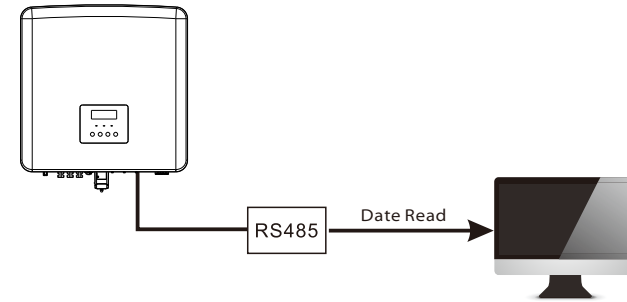

Inverter communication control external equipment:

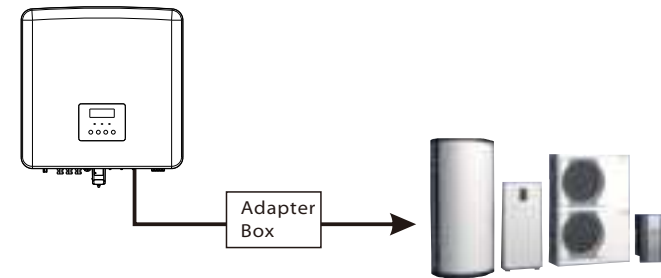

➤ **COM PIN Definition**

	1	2	3	4	5	6	7	8
	Drycontact_A(in)	Drycontact_B(in)	+13V	485A	485B	GND	Drycontact_A(out)	Drycontact_B(out)

Note!

Customers can communicate or control the inverter and external devices through the COM interface. Professional users can use pins 4 and 5 to realize data acquisition and external control functions. The communication protocol is Modbus RTU. For details, please contact us. If the user wants to use the inverter dry contact to control external equipment (such as a heat pump), it can be used with our's Adapter Box. For details, please refer to the Quick Installation Manual of the Adapter Box.

5.5.5 Communication Connection Steps

Step 1. Prepare a communication cable, and then find RJ 45 terminals in the accessory bag.



Step 2. The inverter CAN/DRM/OFF port communication line connection, need to remove the inverter cover plate.

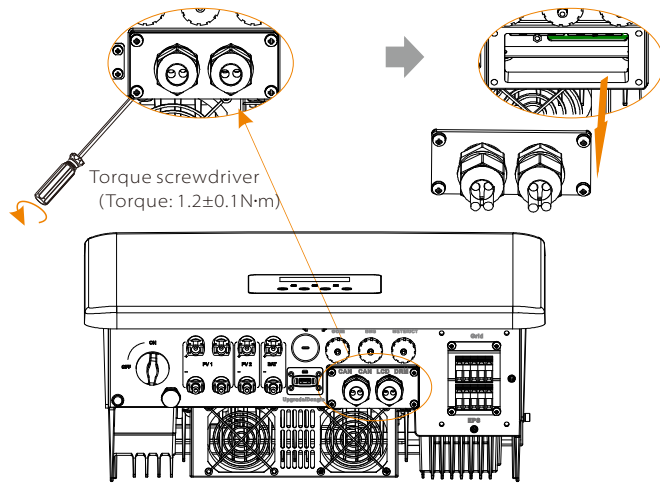

Step 3. Insert the communication cable through the communication adapter, and peel off the outer insulation layer of 15 mm.

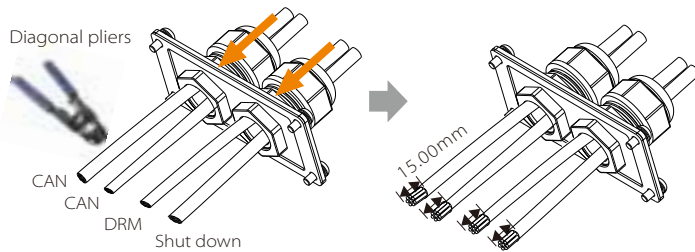

Step 4. Insert the prepared communication cables into the RJ45 terminals in sequence, and then use network cable crimping pliers to press them tightly.

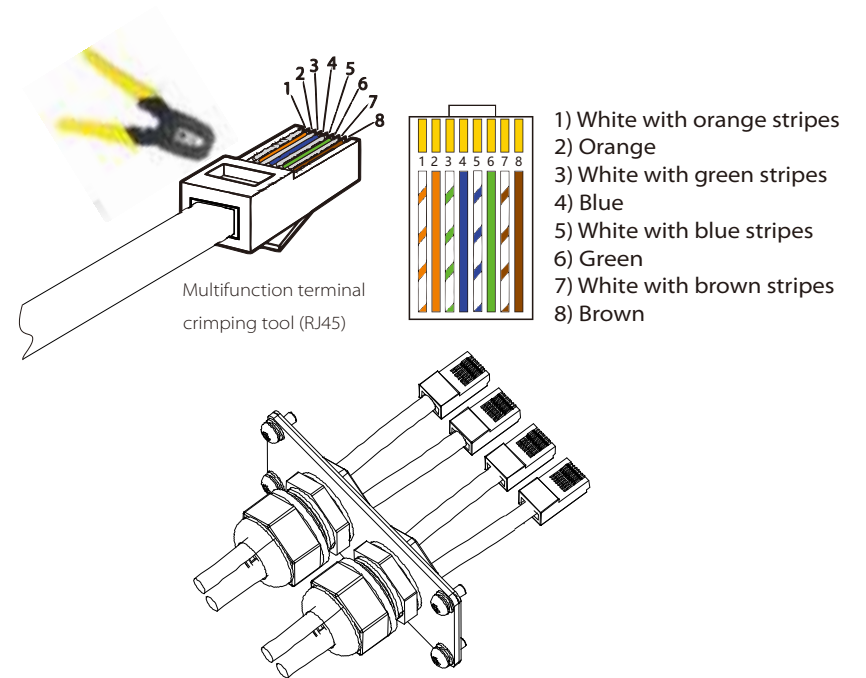

The DRM pin is defined as follows:

➤ DRM communication cable

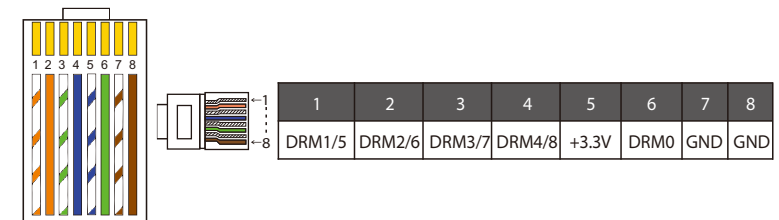

Note!

At present, there are only PIN6 (DRM0) and PIN1 (DRM1 /5), and other PIN functions are under development.

Step 5. Connect the DRM / CAN / OFF communication cable, and insert the cable into the corresponding port.

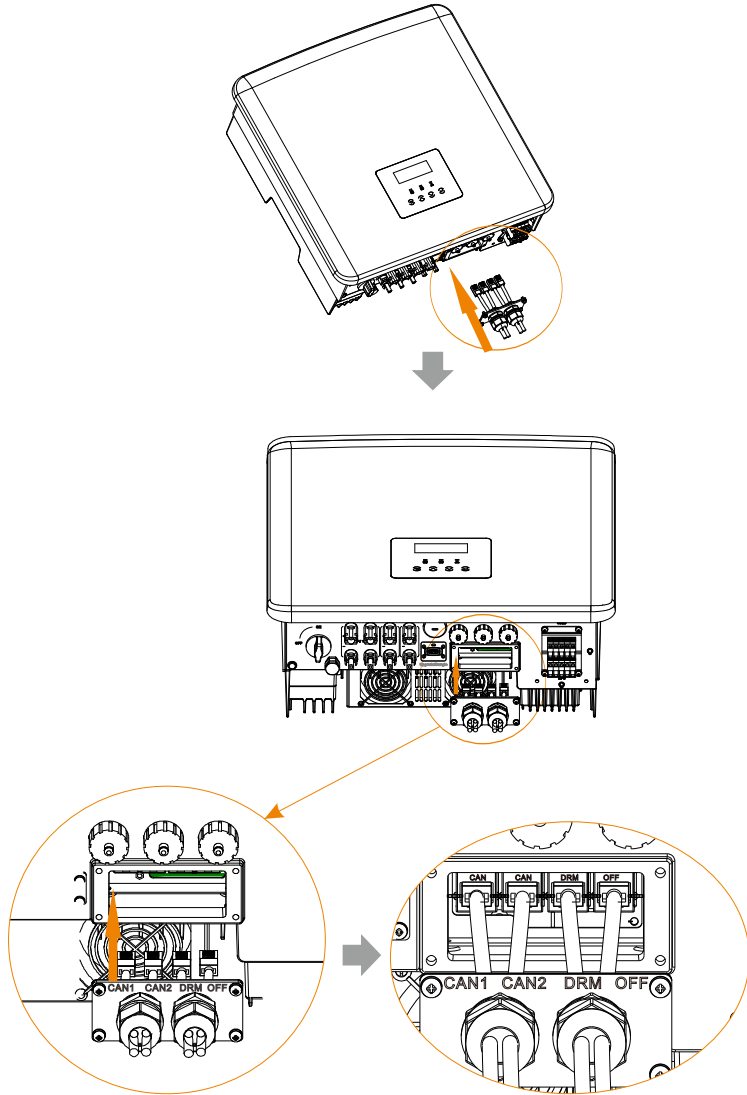

Step 6. Lock the cover plate and tighten the fastening head.

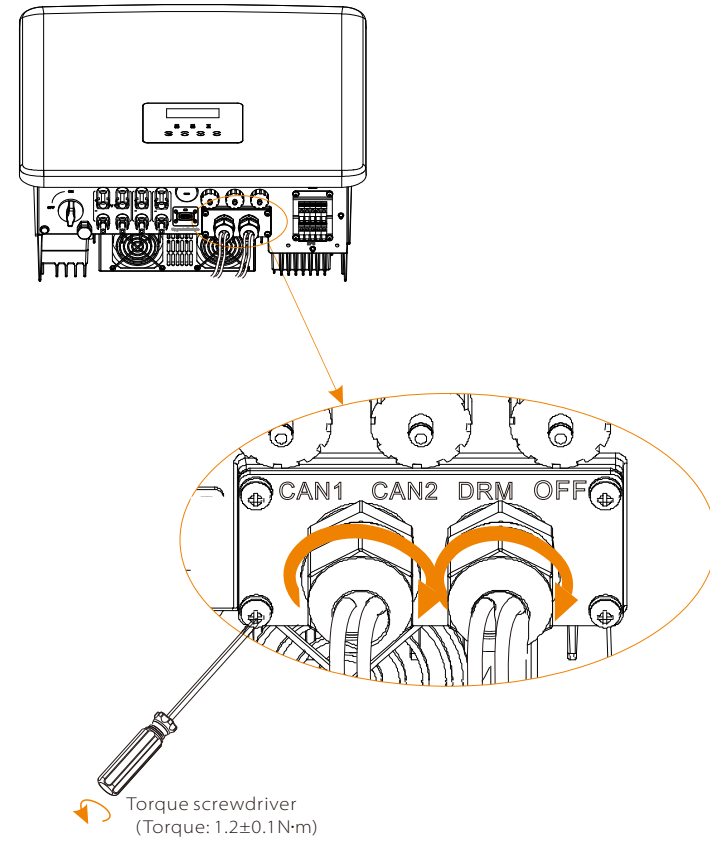

Step 7: Finally, find the corresponding COM, BMS, Meter, CT, CAN, DRM, OFF ports on the inverter and insert the communication cable into the corresponding ports.

➤ **BMS communication cable**

The BMS pin is defined as follows:

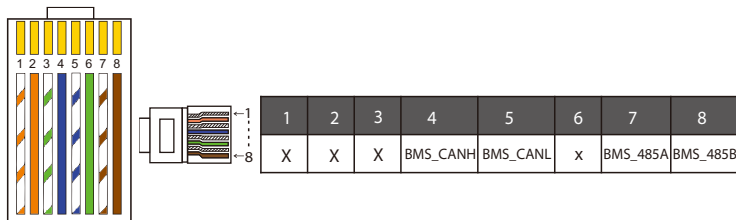

Note!

The communication port on the lithium battery must be consistent with the definition of pins 4, 5, 7, and 8 above;

➤ **METER/CT communication cable**

METER/CT pin is defined as follow:

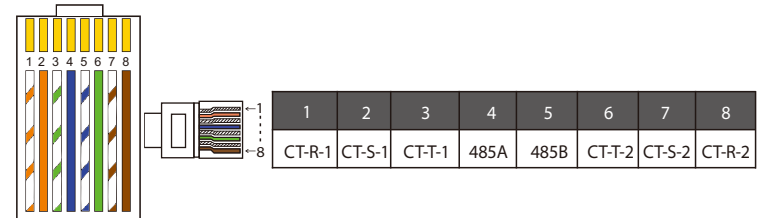

Note!

Only one of the Meter and CT connections can be selected. Meter cable goes to pin terminal 4 and 5; CT-R cable to PIN Terminal 1 and 8; CT-S cable to PIN Terminal 2 and 7; CT-T cable is connected to terminals 3 and 6.

1) Users can customize the length of the CT communication cable. The accessory package provides 1*RJ45 and 1*waterproof connector with RJ45 terminals.

When the CT cable is completed, connect the A terminal to the "CT/METER" port of the inverter and tighten the waterproof screw, and connect the B terminal to the RJ45 coupler.

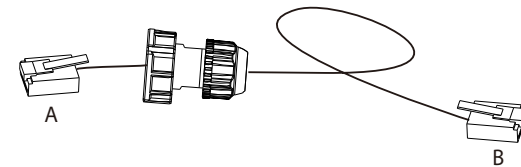

2) One side of the finished cable, Waterproof connector with RJ45 is inserted into the inverter, and one side of the RJ45 terminal is inserted into the CT connection.

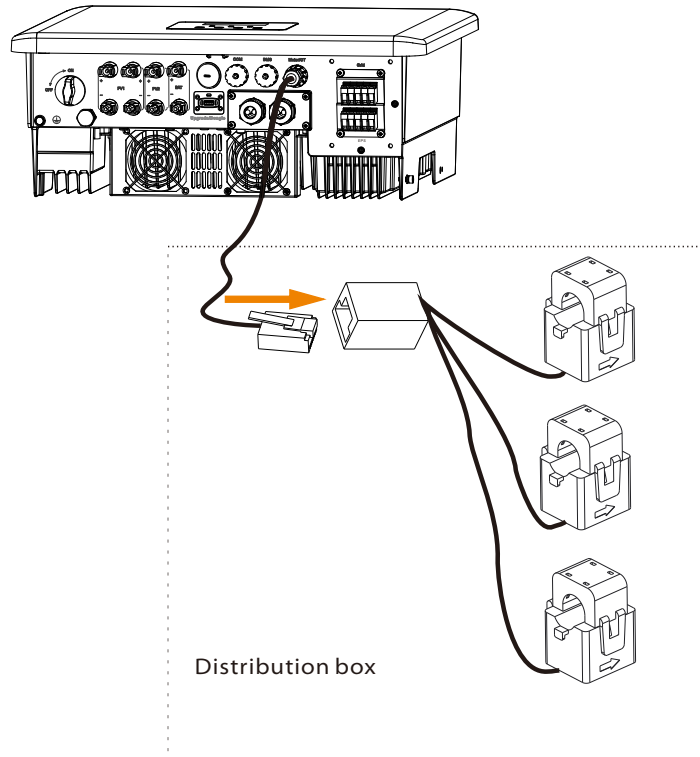

Note!
When installing, pay attention to water resistance. All the connected parts of CT must be put into the distribution cabinet.

Screw waterproof connectors tightly.

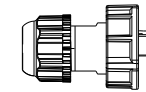

Waterproof connector with RJ 45

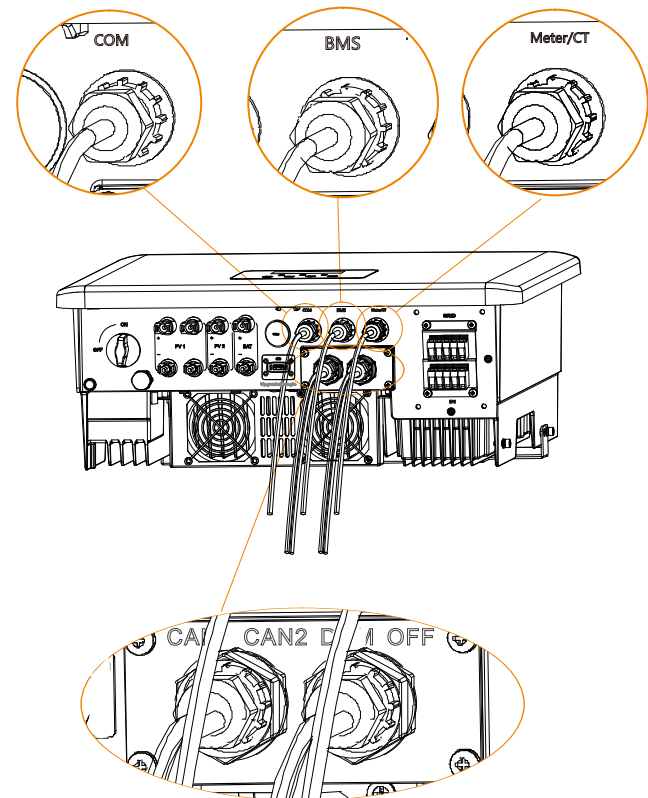

5.6 Grounding Connection (Mandatory)

The user must make two ground connections: one shell grounding, and one equipotential grounding. This prevents electric shock.

Note: If the PV end of the inverter is not connected with earth, the inverter will turn on a red light Inspect and report ISO Fault. This inverter complies with IEC 62109-2 clause 13.9 for earth fault alarm monitoring.

Ground wire port of the M series inverter has been connected, and the D series needs to be wired according to the following steps.

➤ Ground connection steps

Step 1. Prepare a one-core cable (4 mm²), and then find the ground terminal in the accessories.



Step 2. Strip the grounding cable insulation (length "L2"), insert the striped cable into the ring terminal, and then clamp it.

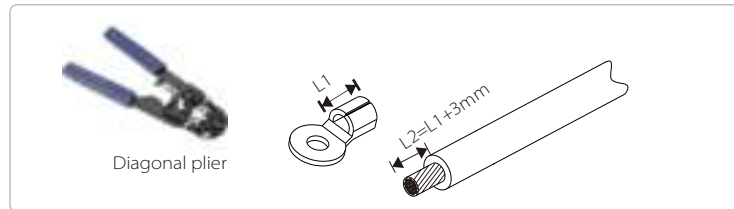

Step 3. Insert the striped cable into OT terminal and tighten the terminal with a terminal crimping tool.

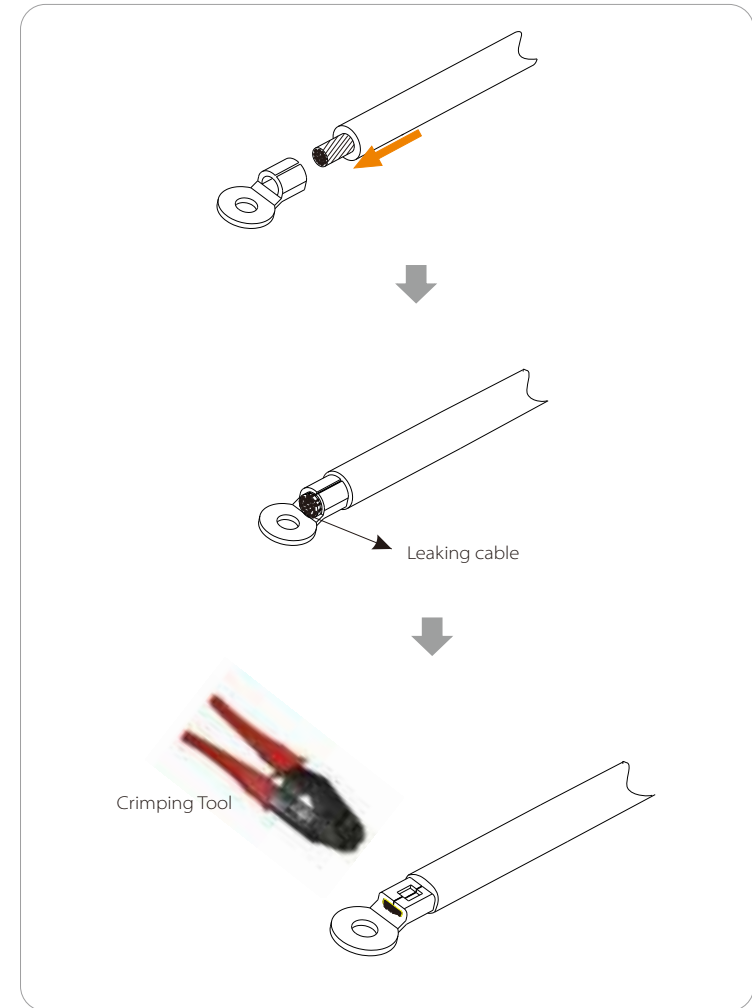

Step 4. Find the ground connection port on the inverter, and screw the ground wire on the inverter with an M5 Hexagon keys.

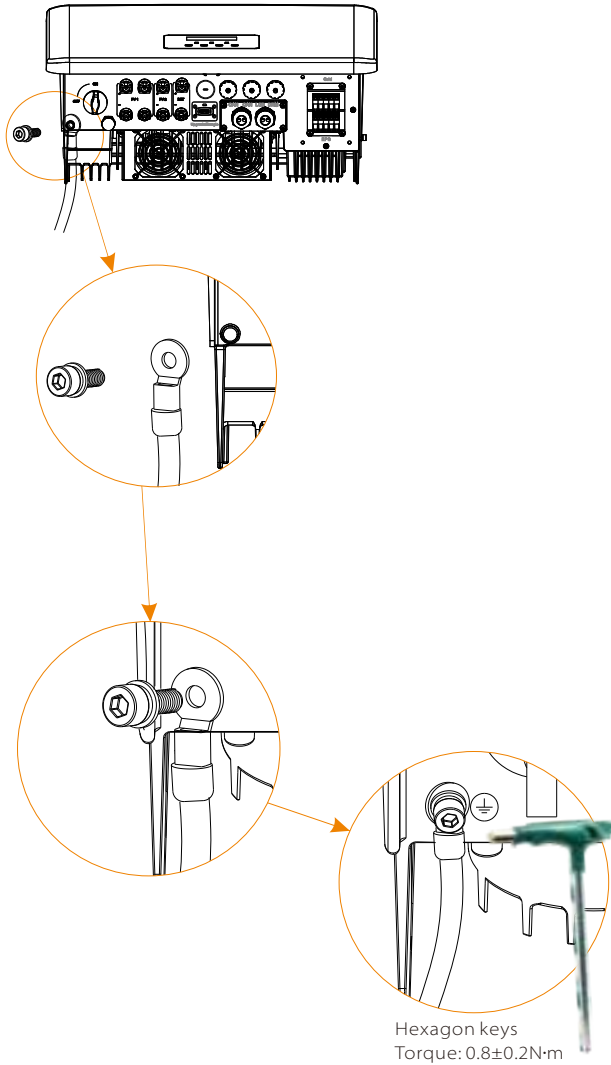

5.7 Monitoring Connection (Accessories)

The inverter provides a DONGLE port, which can transmit data of the inverter to the monitoring website via Pocket WiFi, Pocket 4G and Pocket LAN. (If necessary, purchase products from us.)

➤ DONGLE connection diagram

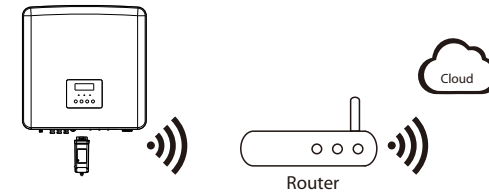

➤ Wireless monitoring accessories connection steps

DONGLE port connection line of the the M series inverter is on the X3-Matebox, for specific installation details, please refer to the X3-Matebox Quick Installation Guide It is necessary to wire the D series according to the following steps.

Step 1. First find the DONGLE port of the inverter.

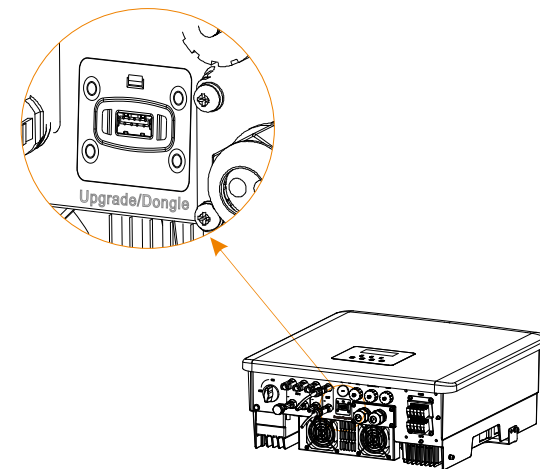

Step 2. Plug Pocket WiFi into the DONGLE port.

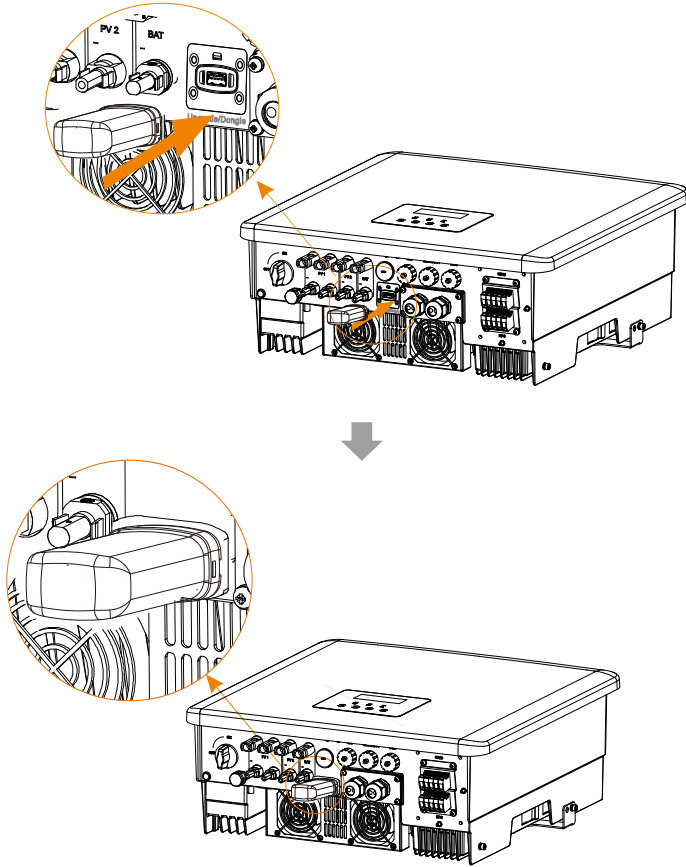

Please check the Pocket WiFi user manual/Pocket LAN user manual/4G user manual.

5.8 Check All Below Steps Before Starting Inverter

➤ After the inverter is checked, then conduct the following steps

- ❶ Make sure that the inverter is fixed on the wall.
- ❷ Ensure that all ground wires are grounded.
- ❸ Confirm that all DC lines and AC lines are connected.
- ❹ Make sure the CT are connected.
- ❺ Make sure the battery is well connected.
- ❻ Turn on the Load switch and EPS(Off-grid) switch.
- ❼ Turn on the battery switch.

Long press the "Enter" key for 5 seconds to exit the Off mode.
(The mode is factory defaulted as Off Mode)

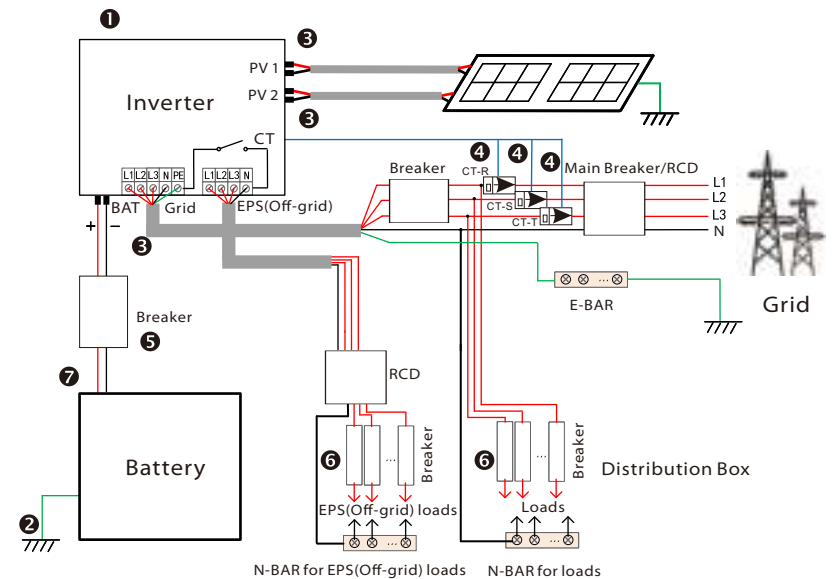

Note: The RCD on the figure represents a leakage protection device with a circuit breaker function.

5.9 Inverter Operation

➤ Before operation, check the inverter according to the following steps

- Check that the inverter is well fixed on the wall.
- Ensure that all ground wires are well tightened.
- Ensure that all DC and AC circuit breakers are disconnected.
- Ensure that all ground wires are well tightened.
- The AC output terminal is correctly connected to the mains.
- Ensure that all photovoltaic panels and inverters are properly connected. Unused DC connectors should be blocked with caps.

➤ Start the inverter

- Steps to start the inverter
 - Turn on the AC switch between the inverter and the power grid.
 - (Optional) Remove the locking screw from the DC switch.
 - Turn on the DC switch between the PV string and the inverter if there is any.
 - Turn on the DC switch at the bottom of the inverter .
- When the photovoltaic panel generates enough power, the inverter will start automatically.
 - If the battery port of the inverter is connected to a battery, turn on the auxiliary power switch of the battery and then the battery switch.
- Check the status of the LED and LCD screen, the LED is blue, and the LCD displays the main interface.
 - If the LED is not blue, please check the following:
 - All connections are correct.
 - All external disconnect switches are closed.
 - The DC switch of the inverter is set to the "ON" position.

The following are 3 different states of inverter operation, which means that the inverter starts successfully.

Waiting: When the DC output voltage of the photovoltaic panel is higher than 160V (lowest starting voltage) and lower than 180V (lowest working voltage), the inverter waits for checking.

Checking: The inverter will automatically detect the DC input. When the DC input voltage of the photovoltaic panel is higher than 200V and the photovoltaic panel has enough energy to start the inverter, the inverter will enter the checking state.

Normal: When the inverter is working normally, the green light is always on. At the same time, the power is fed back to the grid, and the LCD displays the output power.

If it is the first time to boot, please follow the prompts to enter the setting interface.



Warning!

The input terminal of the inverter can be opened only when all the installation work of the inverter has been completed. All electrical connections must be performed by professionals in accordance with local regulations.



Note!

If it is the first time to operate the inverter, the system will automatically display setup guide. Please follow the setup guide to complete the basic inverter settings.

Please follow the setup guide to complete the basic inverter settings.

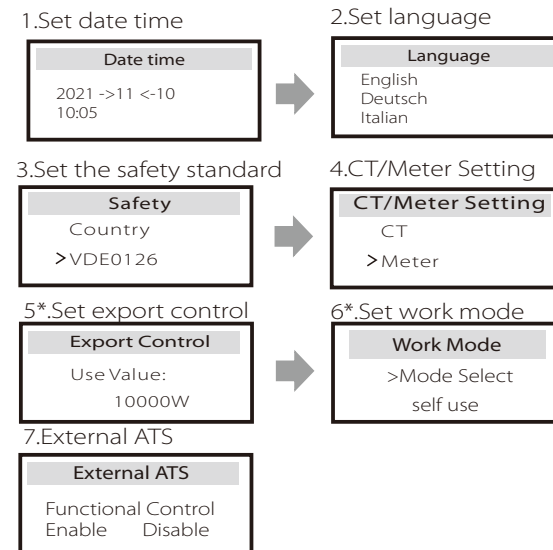

5*. Export Control

This function allows the inverter able to control energy exported to the grid. There are user value and factory value. The factory value is default which can not be changed by user. The user value set by installer must be less than the factory value.

6 Firmware Upgrade

➤ Upgrade notes

Please read the following precautions before upgrading.

Warning!

 - In order to upgrade the firmware smoothly, if the DSP and ARM firmware need to be upgraded, please note that ARM firmware must be upgraded first, then DSP firmware!
 - Please make sure that the category format is correct, do not modify the firmware file name, Otherwise, the inverter may not work!

Warning!

 - For the inverter, ensure that the PV input voltage is greater than 180V (upgrade on sunny days). please ensure that the battery SOC is greater than 20% or the battery input voltage is greater than 180V. Otherwise, it may cause serious failure during the upgrade process!

Caution!

 - If the ARM firmware upgrade fails or stops, please do not unplug the U disk power off the inverter and restart it. Then repeat the upgrade steps.

Caution!

 - If the DSP firmware upgrade fails or stops, please check whether the power is off. If it is normal, plug in the U disk again and repeat the upgrade.

➤ Upgrade preparation

1) Please check the inverter version and prepare a U disk (USB 2.0/3.0) and personal computer before upgrading.

Caution!

 - Please make sure that the size of the U disk is smaller than 32G, and the format is FAT 16 or FAT 32.

2) Please contact our service support to obtain the firmware, and store the firmware in the U disk according to the following path.

Update:
 For ARM file: "update\ARM\618.00406.00_HYB_3P_ARM_V1.13_1220.usb";
 For DSP file: "update\DSP\618.00405.00_HYB_3P_DSP_V1.14_1215.usb";

➤ Upgrade steps

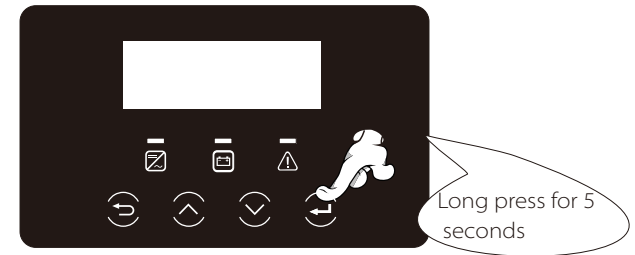
Step 1. Please save the "Upgrade" firmware in your U disk first, and press the "Enter" button on the inverter screen for 5 seconds to enter the OFF mode.



Step 2. Find the "Upgrade" port of the inverter, unplug the monitoring module (Pocket WiFi/ Pocket 4G/Pocket 4G) by hand, and insert the USB flash drive.

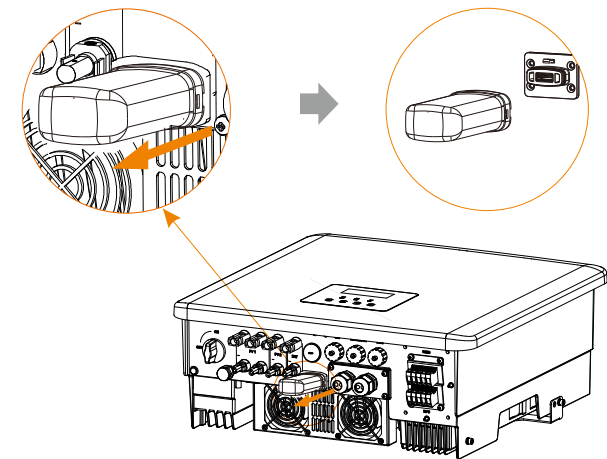

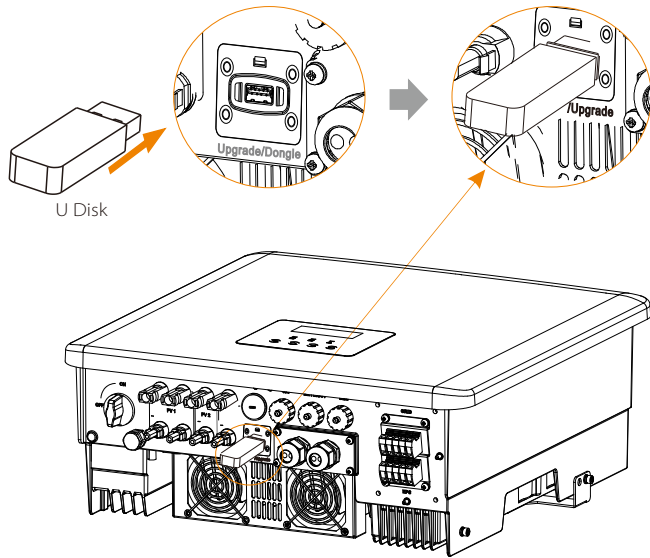

Step 3. LCD operation, enter the upgrade interface "update", as shown below (a): Please press the up and down keys to select ARM, then press down to set "OK", press the enter key to enter the software version interface;

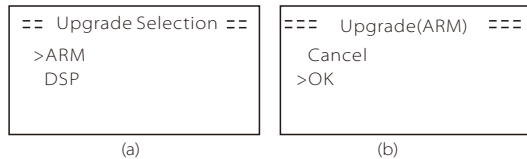

Step 4. Please confirm the new firmware version again and select the firmware to upgrade. The upgrade takes about 20 seconds. (d) When it is completed, the LCD screen returns to the "Update" page.

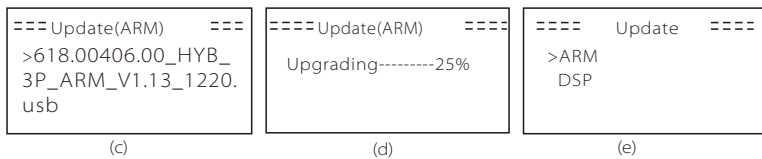

Step 5. For DSP: Please wait for 10 seconds. When "Update" page shown as below, press down to select "DSP" and then press Enter. Please confirm the firmware version again and press Enter to upgrade. The upgrade takes about 2 minutes.

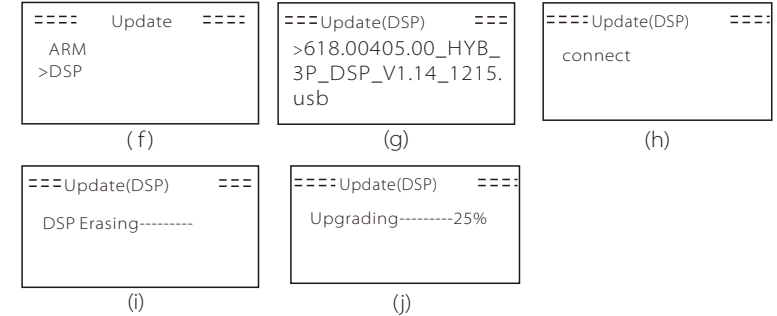

Step 6. After the upgrade is completed, the LCD screen displays "Upgrade Successful".

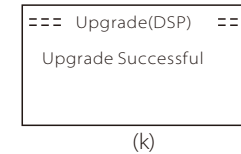

Step 7. Plug off the U disk, press "Esc" to return to the main interface, and long press the enter key to exit the mode.



Caution!

- Please strictly follow each step from step 1-6, don't miss it.
- Please confirm the ARM/DSP firmware version on the USB flash drive.

Tip: If the display screen is stuck on "X3-Hybrid G4" after the upgrade, please turn off the photovoltaic power supply and restart, and the inverter will restart and return to normal. If not, please contact us for help.

7 Setting

7.1 Control Panel

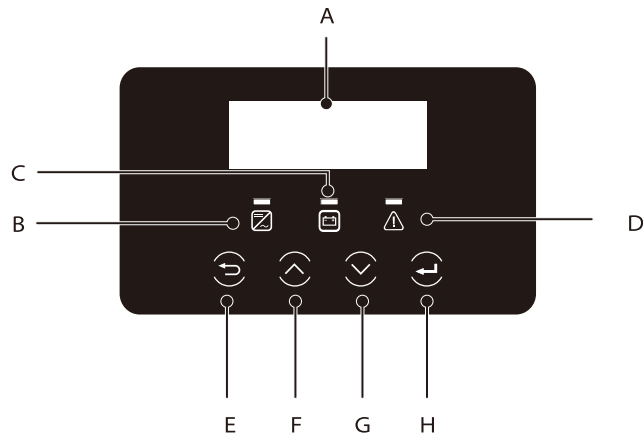

Object	Name	Description
A	LCD Screen	Display inverter information on the LCD display.
B	LED Indicator light	Blue light: The inverter is in normal state or EPS(Off-grid) mode. Blue flashing: The inverter is in the waiting, checking state or the system switch is off. Off: The inverter is in a fault state.
C		Green: The battery communication is normal but the battery MCB is disconnected, and the battery communication is normal and working normally. Green flashing: The battery communication is normal and in an idle state. Off: The battery does not communicate with the inverter.
D		Red light on: The inverter is in a fault state. Off: The inverter has no error.
E		Key Function
F	Up button: Move the cursor to the upper part or increase the value.	
G	Down button: Move the cursor down or decrease the value.	
H		Enter button: Confirm selection.

7.2 Screen Menu Structure

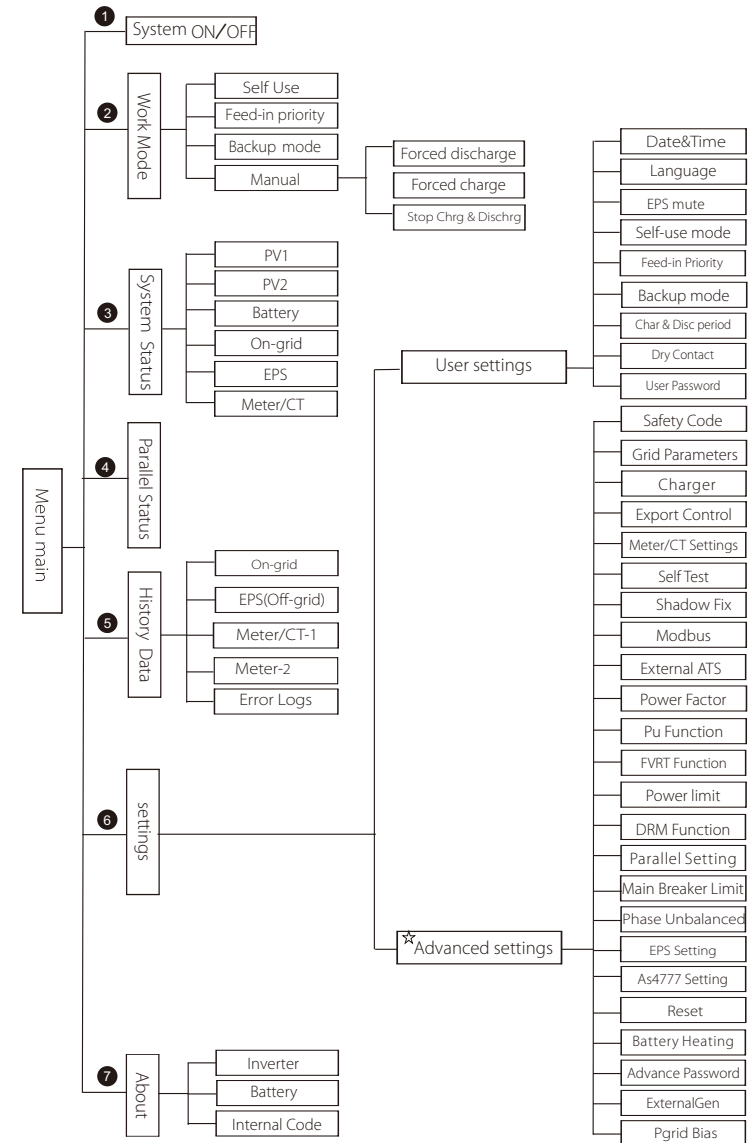

Note: "★" This part of the content cannot be set by the end user. Please contact the installer or our company if necessary.

7.3 LCD Operation

The main interface is the default interface, the inverter will automatically return to this interface when the system started up successfully or not operated for a period of time.

The information of the interface is as below. "Power" means the instant output power; "Today" means the power generated within the day. "Battery" means the left capacity of battery energy.

Power	0W
Today	0.0KWh
Battery	80%
Normal	

➤ Menu interface

The menu interface is another interface for users to change settings or obtain information.

- When the LCD displays the main interface, click "OK" to enter this interface.
- The user can select up and down the menu, and press the "OK" key to confirm.

Menu
>System ON/OFF
Work Mode
System Status

➤ Menu main

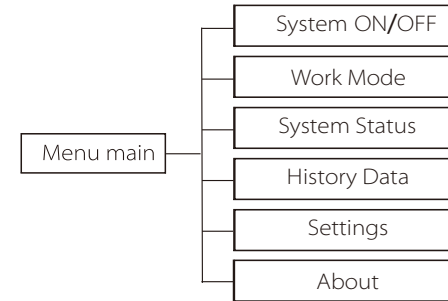

➤ System ON/OFF

"ON" means the inverter is in working state, and the inverter is in the default state.

"OFF" means that the inverter stops running and only the LCD screen is on.

System ON/OFF
Switch
>ON<

➤ Work Mode

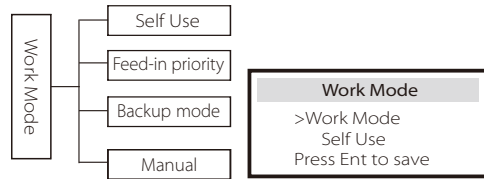

Mode selection, there are 4 working modes to choose from.

Name	Description
Self Use	<p>The self-use mode is suitable for areas with low feed-in subsidies and high electricity prices.</p> <p>① When the power of PV is sufficient Active Charging or Discharge time period: PV will power the battery. When the battery is fully charged, PV will power the load, and then sell the surplus power to the grid.(The inverter will limit the output if Feed-in limit or zero feed-in is needed) (PV > Battery charge, PV → Battery → Load → Grid)</p> <p>② When the power of PV is insufficient Active Charging time period: PV will power the battery and the remaining power will be taken from the grid when PV is not enough. PV and grid power will charge the battery until it reaches the set value. And then PV will power the load and the remaining power will be taken from the grid when PV is not enough. The battery will not discharge at this time. (PV < Battery charge, PV + Grid → Battery) Active Discharge time period: PV+BAT will power the loads together. If the power is still not enough, the remaining power will be taken from the grid. (PV < Load, PV + Battery + Grid → Load)</p> <p>③ Without PV power Active Charging time period: The grid supplies the loads and also can charge the battery; (PV=0, Grid → Load + Battery) Active Discharge time period: The battery will power the home loads firstly. If the battery power is not enough, the remaining power will be taken from the grid. The inverter will enter into the idle mode. (PV=0, Battery+Grid → Load) Battery min SOC can be set:10%-100%; Charge battery to min SOC can be set:10%-100%.</p>
Feed-in priority	<p>The Feed-in priority mode is suitable for areas with high feed-in subsidies, but has feed-in power limitation.</p> <p>① When the power of PV is sufficient Active Charging time period: PV power the battery to the set value, and then power the load, and sell the surplus power to the grid. If the local grid company limits the grid-connected power of the inverter, the excess energy continues to charge the battery. (PV > Battery, PV → Battery → Load → Grid → Battery)</p> <p>Active Discharge time period: PV will power the loads firstly, and surplus power will feed-in to the grid. (PV < Load, PV → Load → Grid)</p>

Feed-in priority	<p>② When the power of PV is insufficient Active Charging time period: PV will power the battery and the remaining power will be taken from the grid when PV is not enough. PV and grid power will charge the battery until it reaches the set value. And then PV will power the load and the remaining power will be taken from the grid when PV is not enough. The battery will not discharge. (PV < Battery charge, PV + Grid → Battery) Discharge time period: PV+BAT will power the loads together. If the power is still not enough, the remaining power will be taken from the grid. (PV < Load, PV + Battery + Grid → Load)</p> <p>③ Without PV power Active Charging time period: The grid will power the home loads and also charge the battery; (PV=0, Grid → Load + Battery) Active Discharge time period: The battery will power the home loads firstly. If the battery power is not enough, the remaining power will be taken from the grid. The inverter will enter into the idle mode. (PV=0, Battery+Grid → Load) Battery min SOC can be set:10%-100%; Charge battery to min SOC can be set:10%-100%.</p>
Backup mode	<p>The Back-up mode is suitable for areas with frequent power outages. Same working logic with "Self-use" mode. This mode will maintain the battery capacity at a relatively high level. (Users' setting) to ensure that the emergency loads can be used when the grid is off. Customers no need to worry about the battery capacity. Battery min SOC can be set:30%-100%. Charge battery to min SOC can be set:30%-100%.</p>
EPS (Off-grid)	<p>The EPS(Off-grid) mode is used when the power grid is off. System will provides emergency power through PV and batteries to supply power to the household loads. (Battery is necessary)</p> <p>① When the power of PV is sufficient PV will power the loads firstly, and surplus power will charge to the battery. (PV > Load, PV → Load → Battery)</p> <p>② When the power of PV is insufficient The remaining power will be taken from the battery. (PV < Load, PV+Battery → Load → Battery)</p> <p>③ Without PV power The battery will power the emergency loads until the battery reached the min SOC, then the inverter will enter into the idle mode. (PV=0, Battery → Load) EPS(off-grid) SOC-min condition is adjustable within the range of 10%-25%;</p>

Note: in the case of grid connection, all working modes work normally when the battery SOC >5%. When the Min SOC of the system - the actual SOC of the battery > 5%, PV or Grid will force the battery to charge to Min SOC +1%, and then return to the normal working mode set by the user.

Note: when the actual SOC of the battery is ≤ Min SOC, if the mains power is lost, the inverter will not enter the EPS (Off-grid) mode. The inverter is in EPS Waiting state, at which time the PV will charge the battery. When the battery capacity reaches 31%, the machine will automatically enter EPS (Off-grid) mode.

- Manual mode, there are three options to choose from: forced charging, forced discharge, stop charging and discharging (grid-connected power).

Work Mode >Manual Forced Charge	Work Mode >Manual Forced Discharge	Work Mode >Manual Stop Chrg&Dischrg
--	---	--

➤ System Status

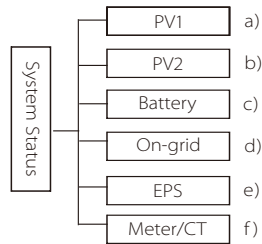

System status contains six content: PV1/PV2/Battery/On-grid (energy feed into or buy from the grid)and EPS(Off-grid) and so on. Press up and down to select, press "Enter" to confirm the selection, and press "ESC" to return to the menu.

a/b) PV1, PV2

Here you can see the voltage, current and power of the pv1 and Pv2. Photovoltaic panels respectively;

PV1		PV2	
>U	0.0V	>U	0.0V
I	0.0A	I	0.0A
P	0W	P	0W

c) Battery

This status shows the battery condition of the system. Including battery voltage and battery current, Battery power, battery capacity, battery temperature, BMS connection status. The meaning of the sign of battery current and power: "+" means charging; "-" means discharging.

Battery		Battery	
U	400.0V	U	400.0V
I	-1.0A	I	-1.0A
P	-400W	P	-400W
SoC	0%		
Cell Temp	20°C	NTCTemp	
BMS Connected			

d) On-grid

Here you can see the voltage, current, frequency, and power of the grid.

On-grid A		On-grid B	
Ua	0.0V	Ub	0.0V
Ia	0.0A	Ib	0.0A
PaOut	0W	PbOut	0W

On-grid C		Grid Frequency	
Uc	0.0V	Fa	0.00Hz
Ic	0.0A	Fb	0.00Hz
PcOut	0W	Fc	0.00Hz

e) EPS

Here you can see the inverter of voltage, current, frequency and power.

EPS_Spower		EPS A		Frequency	
PaS	0VA	Ua	0.0V	Freq	0.00Hz
PbS	0VA	Ia	0.0A		
PcS	0VA	PaActive	0W		

EPS B		EPS C	
Ub	0.0V	Uc	0.0V
Ib	0.0A	Ic	0.0A
PbActive	0W	PcActive	0W

f) Meter/CT

Here you can see the data showing the meter or the CT.

Meter/CT	
>Meter/CT1-A	-6w
Meter/CT1-B	-6w
Meter/CT1-C	-6w
> Meter2-A	-6w
Mete2-B	-6w
Meter2-C	-6w

➤ Parallel Status

Status shows on the screen when paralleling.

Parallel Status	
All	3
Slaver1	O
Slaver2	X
Slaver3	O
Slaver4	X
Slaver5	X
Slaver6	X
Slaver7	X
Slaver8	X
Slaver9	X

➤ History Data

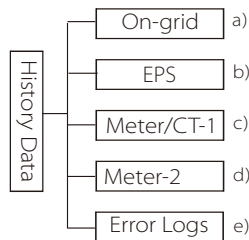

The history data contains five pieces of information: on-grid power of the inverter, EPS power generation, power of the meter /CT and error Error logs.

Press up and down to select, press Enter to confirm selection, and press ESC to return to the menu.

a) On-grid

Here is a record of the power capacity of the inverter connected to the grid today and the total.

On-grid	
Output Today	0.0 KWh
Output Total	0.0 KWh
Input Today	0.0 KWh
Input Today	0.0 KWh

b) EPS

Here you can see the EPS output of the inverter today and the total output.

EPS	EPS
Today: 0.0 KWh	Total: 0.0 KWh

c) Meter /CT-1

Here you can see the inverter's electricity sold, total electricity sold, electricity bought from the grid and total electricity bought on that day.

Meter CT-1
>FeedInToday
FeedInTotal
ConsumeToday
ConsumeTotal

d) Meter-2

Here you can see the total power output of the inverter for the day.

Meter-2
>Output Today
OutputTotal

e) Error Logs

Here you can see the most recent six error messages.

Error logs
>No error

➤ User Settings

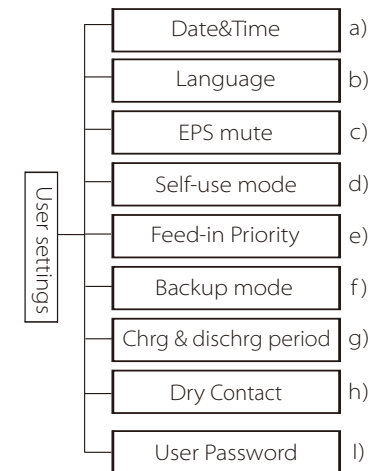

Here you can set the inverter time, language, working mode SOC, charging and discharging time period and user password.

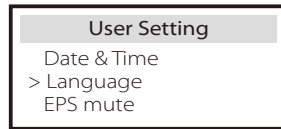

a) Date time

This interface is for users to set the system date and time.

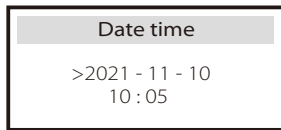

b) Language

This inverter provides multiple languages for customers to choose, such as English, Deutsch, francais, Polskie, Espanol, Portugués.

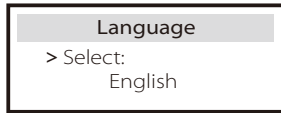

c) EPS Mute

Here you can choose whether the buzzer is turned on when the inverter is running in EPS mode. Select Yes, the buzzer mutes, select NO, EPS mode, the buzzer will sound once every 4s when the battery is fully charged, the closer the battery is to the empty state, the higher the buzzer will sound, to remind users to avoid battery loss.

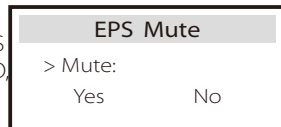

d) Self-use mode

In this mode, you can set the power reserve percentage of the minimum battery state, set whether the power can be taken from the mains side to charge the battery, and set the amount of power to charge the battery. For example: set the reserved minimum SOC of the battery capacity to "10%", which means that when the battery has been discharged to 10% of the battery capacity, the battery is not allowed to continue to discharge; When Charge from grid is set to "Enable", the utility power is allowed to charge the battery; when set to "Disable", the utility power is not allowed to charge the battery; Charge battery to is set to 10%, indicating that the mains is allowed to charge the battery at 10%.

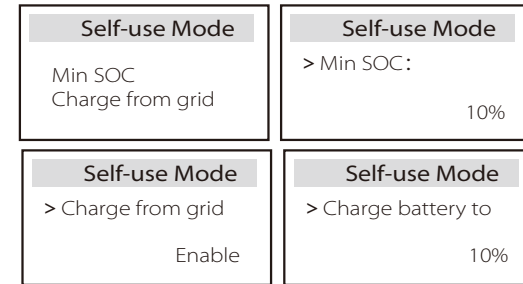

e) Feed-in Priority

In this mode, you can set the power reserve percentage of the minimum battery state, set whether the power can be taken from the mains side to charge the battery, and set the amount of power to charge the battery. For example: set the reserved minimum SOC of the battery capacity to "10%", which means that when the battery has been discharged to 10% of the battery capacity, the battery is not allowed to continue to discharge;

Charge battery to is set to 50%, indicating that the mains is allowed to charge the battery at 50%.

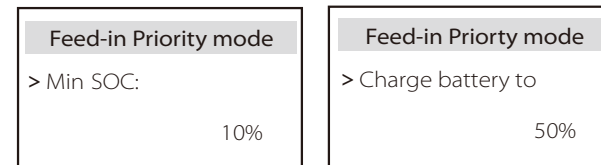

f) Backup mode

In this mode, you can set the power reserve percentage of the minimum battery state, set whether the power can be taken from the mains side to charge the battery, and set the amount of power to charge the battery. For example: set the reserved minimum SOC of the battery capacity to "30%", which means that when the battery has been discharged to 30% of the battery capacity, the battery is not allowed to continue to discharge;

Charge battery to is set to 50%, indicating that the mains is allowed to charge the battery at 50%.

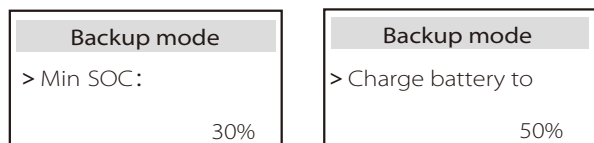

g) Charge and discharge time

Here you can set the charge and discharge time period. If two charging and discharging periods are needed, turn on the charging and discharging period 2 and set the period.

Char&Disc Period > Charge Start Time 00:00	Char&Disc Period > Charge End Time 00:00	Char&Disc Period > Allowed Disc Period Start Time 00:00
Char&Disc Period > Allowed Disc Period End Time 23:59	Char&Disc Period2 > Char&Disc Period2	Char&Disc Period2 > Function Control Enable
Char&Disc Period2 > Charge Start Time 00:00	Char&Disc Period2 > Charge End Time 00:00	Char&Disc Period2 > Allowed Disc Period Start Time 00:00
Char&Disc Period2 > Allowed Disc Period End Time 00:00		

h) Dry Contact

When the user uses the inverter communication control external device function, you can enter here to set the parameters of the external response control. For the setting method, please refer to the user manual of the compatible external device.

If the user uses the inverter dry contacts to control external devices (such as heat pumps) through the Adapter box, please refer to the Adapter box quick installation manual to set the parameters here.

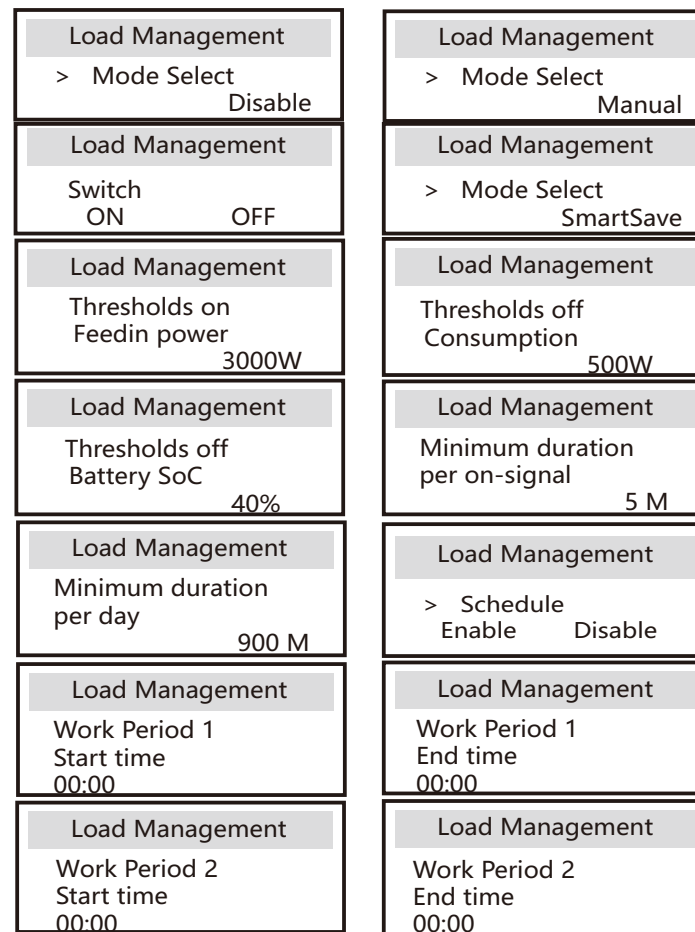

i) User Password

The default password for the end user is "0000", where you can reset the new password and press the up/down key to increase or decrease the value. Press "Enter" to confirm the value and jump to the next digit. When all passwords have been entered and confirmed, press "OK" to set the password successfully.

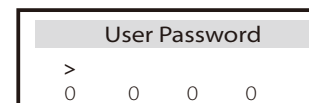

➤ Advance settings

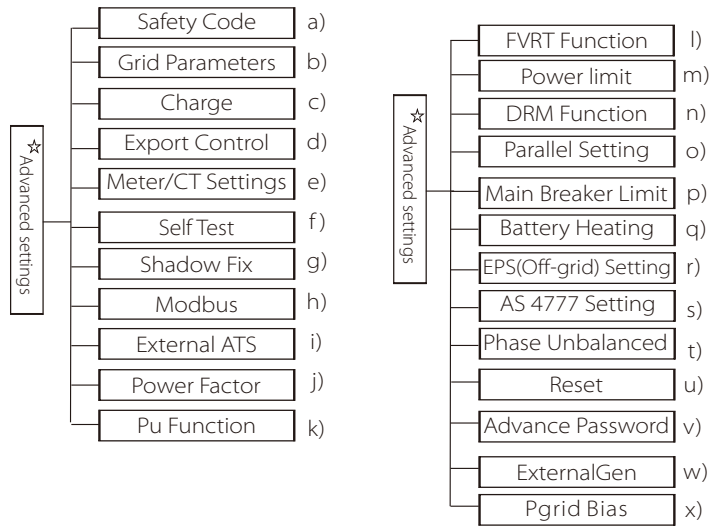

All advanced settings can be set here, such as battery, grid, EPS(Off-grid), etc.

"Advanced" setting is generally customization and resetting for battery and grid. Each part has lower level parts.

Please contact your installer or factory and enter the installer password.

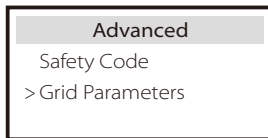

a) Safety code

User can set safety standard according to different countries and grid tied standards. There are 8 standards to select. **(May be changed or added without notice)**

Item	Standard	Country
1	VDE 0126	German
2	ARN 4015	German
3	AS 4777	Australia
4	EN 50549_EU	Netherland
5	G98/G99	UK
6	EN 50438_NL	Netherland
7	CEI 0-21	Italy
8	IEC61727_In	India

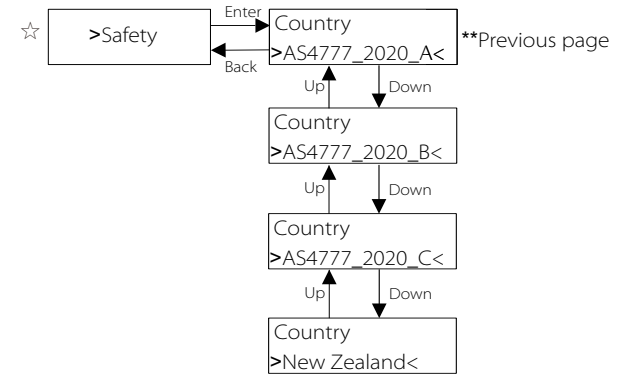

Region	Australia A	Australia B	Australia C	New Zealand	
Standard Code Name	AS4777_2020_A	AS4777_2020_B	AS4777_2020_C	New Zealand	Setting Range
OV-G-V	265V	265V	265V	265V	230-300V
OV-G-V2	275V	275V	275V	275V	1-2S
OV-GV2-T	0.1S	0.1S	0.1S	0.1S	230-300V
UN-G-V1	180V	180V	180V	180V	0-0.2S
UNGV1-T	10S	10S	10S	10S	40-230V
UN-G-V2	70V	70V	70V	70V	10-11S
UNGV2-T	1.5S	1.5S	1.5S	1.5S	40-230V
OV-G-F1	52HZ	52HZ	55HZ	55HZ	1-2S
OVGF1-T	0.1S	0.1S	0.1S	0.1S	50-55HZ
OV-G-F2	52HZ	52HZ	55HZ	55HZ	0-0.2S
OVGF2-T	0.1S	0.1S	0.1S	0.1S	50-55HZ
OV-GV1-T	1.5S	1.5S	1.5S	1.5S	0-0.2S
UN-G-F1	47HZ	47HZ	45HZ	45HZ	45-50HZ
UNGF1-T	1.5S	1.5S	5S	1.5S	1-6S
UN-G-F2	47HZ	47HZ	45HZ	45HZ	45-50HZ
UNGF2-T	1.5S	1.5S	5S	1.5S	1-6S
Startup-T	60S	60S	60S	60S	15-1000S
Restore-T	60S	60S	60S	60S	15-600S
Recover-VH	253V	253V	253V	253V	
Recover-VL	205V	205V	205V	198V	
Recover-FH	50.15Hz	50.15Hz	50.15Hz	50.15Hz	
Recover-FL	47.5Hz	47.5Hz	47.5Hz	47.5Hz	
Start-VH	253V	253V	253V	253V	
Start-VL	205V	205V	205V	198V	
Start-FH	50.15Hz	50.15Hz	50.15Hz	50.15Hz	
Start-FL	47.5Hz	47.5Hz	47.5Hz	47.5Hz	

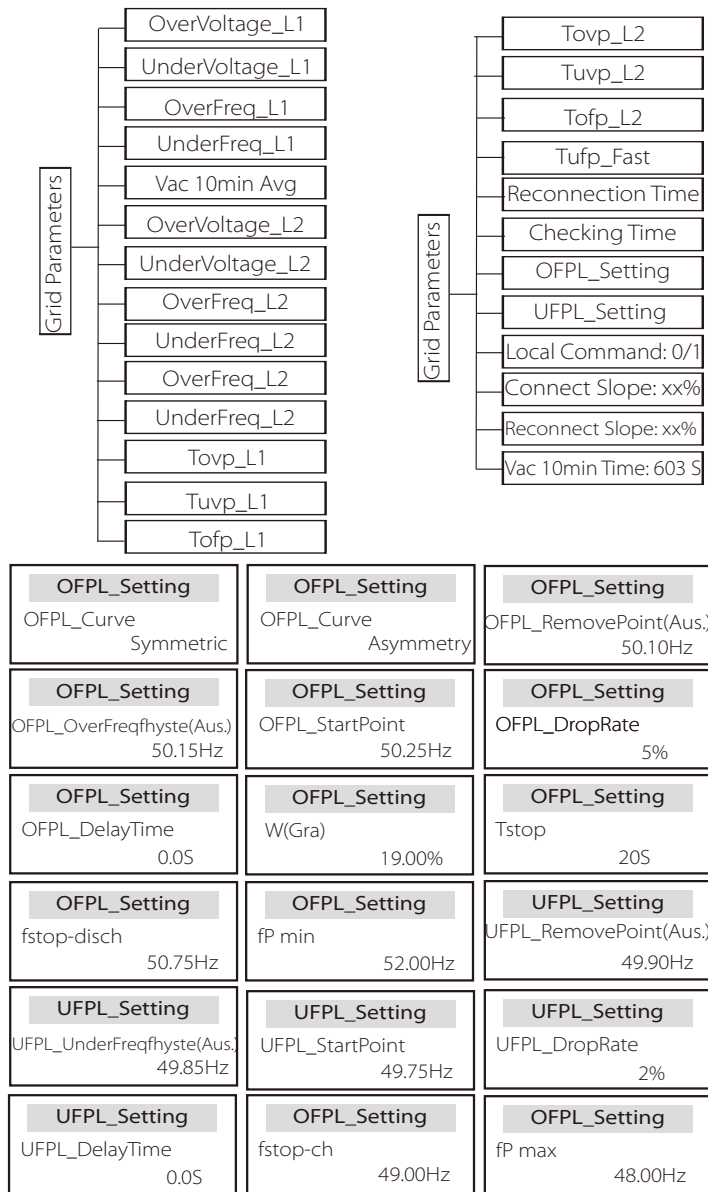

b) Grid Parameters

Here you can set the protection value of grid voltage and frequency. The default value is the specified value under the current safety regulations, and the user cannot change it.

The display content will be displayed according to the requirements of local laws and regulations, which are constantly increasing. Please refer to the contents displayed on the inverter screen.

Grid Parameters >OverVoltage_L1 265.0V	Grid Parameters >UnderVoltage_L1 180.0V	Grid Parameters >OverFreq_L1 52.00Hz
Grid Parameters >UnderFreq_L1 47.00Hz	Grid Parameters >Vac 10min Avg 258.0V	Grid Parameters >OverVoltage_L2 275.0V
Grid Parameters >UnderVoltage_L2 70.0V	Grid Parameters >OverFreq_L2 52.00Hz	Grid Parameters >UnderFreq_L2 47.00Hz
Grid Parameters >Tovp_L1 1000ms	Grid Parameters >Tuvp_L1 10000ms	Grid Parameters >Tofp_L1 100ms
Grid Parameters >Tufp_L1 1000ms	Grid Parameters >Tovp_L2 100ms	Grid Parameters >Tuvp_L2 1000ms
Grid Parameters >Tofp_L2 100ms	Grid Parameters >Tufp_L2 1000ms	Grid Parameters >Reconnection Time 60s
Grid Parameters >Checking Time 60s		

c) Charger

Here the user can set the parameters of charger on this page, the inverter is compatible with both lithium battery. Users can set the charge & discharge parameters.

For the detailed parameters, please refer to below table.

Charger Charge Max Current 30 A	Charger Discharge Max Current 30 A
---	--

d) Export Control

This feature allows the inverter to control the amount of electricity output to the grid. The factory value is the default and can be changed by the user. The user value set by setup must be less than the maximum. If the user does not want to supply power to the grid, set it to 0.



e) Meter/CT Settings

The user needs to select the CT or electricity meter to connect the inverter here. CT is a default, when users choose CT, there is only Meter 2 Addr setting. All will show on the inverter screen when users choose Meter.

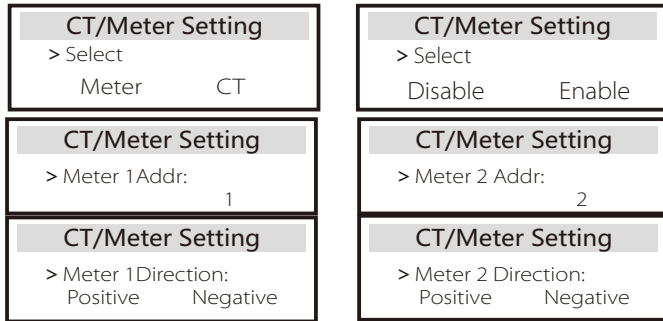

f) Self Test (only for CEI 0-21)

The self test function allows users to test the following items. "Full test", "Ovp(59.S2) test", "Uvp (s1) test", "Uvp (27. s2) test", "Ofp (81 > .S1) test", "Ufp (81 < .S1) test", "Ufp (81 > .S2) test", "Ufp (81 < .S2) test", "Ovp10 (59. s1) test".

In the self-test interface, the user can select "all tests" or a single test item for testing.

Before testing, make sure that the inverter is connected to the grid. All tests take about 6 minutes. And it will display "Success" and then "Delivery".

For a single test item, it takes about a few seconds or minutes. Click "Test Report" to view the test results of all items.

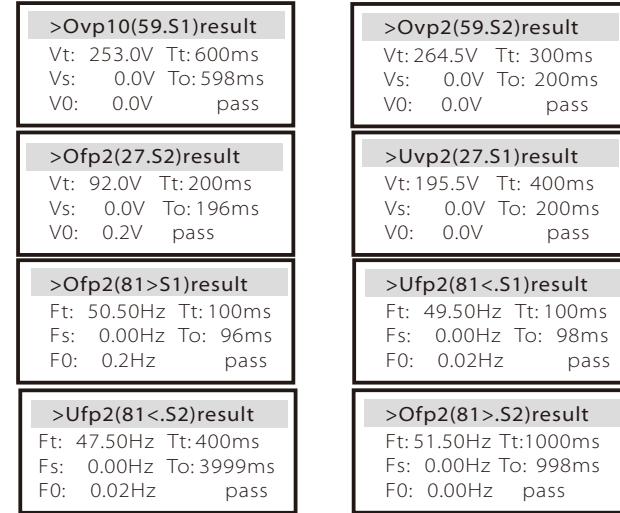
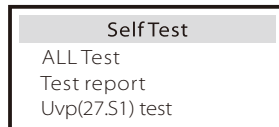

g) Shadow Fix

Here, you can set the shadow tracking with four options, which are off, low, middle, and high.

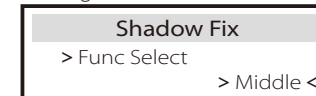

h) Modbus

Here you select the baud rate of the external communication protocol.



i) External ATS

If you want Matebox installed, you need to turn this feature on here. "Disable" is a default.

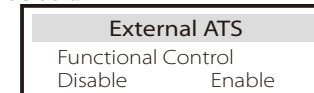

j) Power Factor (applicable to specific countries, please refer to local grid requirements)



Power Factor

Mode Select

> Under-Excited <

Power Factor

Mode Select

> Curve <

Power Factor

Mode Select

> Q(u) <

Power Factor

Mode Select

> Fixed Q Power <

Mode	Comment
Off	-
Over-Excited	PF value
Under-Excited	PF value
Curve	P1_PF
	P2_PF
	P3_PF
	P4_PF
	Power 1
	Power 2
	Power 3
	Power 4
	PFLockInPoint (EU50549 only)
	PFLockOutPoint (EU50549 only)
Q(u)	3Tau
	SetQuPower1
	SetQuPower2
	SetQuPower3
	SetQuPower4
	QuRespondV1(AS4777.2 only)
	QuRespondV2(AS4777.2 only)
	QuRespondV3(AS4777.2 only)
	QuRespondV4(AS4777.2 only)
	K
	3Tau
	QuDelayTimer
	QuLockEn
Fixed Q Power	Q Power

QuLockSetting

QuLockFunction

Enable Disable

QuLockSetting

QuLockIn

20%

QuLockSetting

QuLockOut

5%

k) PU Function (applicable to specific countries, please refer to local grid requirements)

The PU function is a volt-watt response mode required by certain national standards such as AS4777.2. This function can control the active power of the inverter according to the grid voltage. Selecting "Enable" means that this function is turned on and is the default value.

Select "Disable" to deactivate the function.

<p style="text-align: center;">PU Function</p> <p>>PuFunction</p> <p style="text-align: center;">Enable</p>	<p style="text-align: center;">PU Function</p> <p>Response V2</p> <p style="text-align: center;">220.0V</p>	<p style="text-align: center;">PU Function</p> <p>Response V3</p> <p style="text-align: center;">250.0V</p>
<p style="text-align: center;">PU Function</p> <p>Response V4</p> <p style="text-align: center;">265.0V</p>	<p style="text-align: center;">PU Function</p> <p>3Tau</p> <p style="text-align: center;">6~180S</p>	<p style="text-align: center;">PU Function</p> <p>SetPuPower 1</p> <p style="text-align: center;">100%</p>
<p style="text-align: center;">PU Function</p> <p>SetPuPower 2</p> <p style="text-align: center;">50%</p>	<p style="text-align: center;">PU Function</p> <p>SetPuPower 3</p> <p style="text-align: center;">0%</p>	<p style="text-align: center;">PU Function</p> <p>SetPuPower 4</p> <p style="text-align: center;">0%</p>
<p style="text-align: center;">PU Function</p> <p>3Tau_Charge</p> <p style="text-align: center;">10 S</p>	<p style="text-align: center;">PU Function</p> <p>Pu Type</p> <p style="text-align: center;">Static Dynamics</p>	

l) FVRT Function(apply to50549)

Here you can set the high and low enable or disable.

FVRT Function

Function Control

Disable Enable

m) Power limit

Power limit function, the maximum power of the AC port can be set by percentage.

Power Limit

>Proportion

1.00

● Reactive power control, reactive power standard curve $\cos \varphi = f(P)$

For VDE ARN 4105, the curve $\cos = f(P)$ should refer to curve B. The set default value is shown in curve B.

For e8001, the curve $\cos = f(P)$ should be curve A. The set default value is shown in curve A.

For CEI 0-21, the default value of PFLockInPoint is 1.05. When $V_{ac} > 1.05V_n$, $P_{ac} > 0.2 P_n$, curve $\cos c_p = f(P)$ corresponds to curve B.

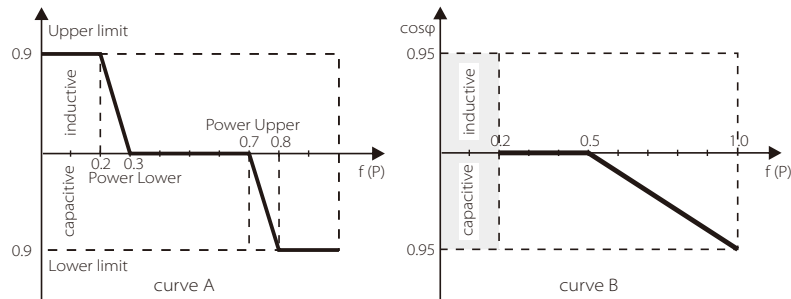
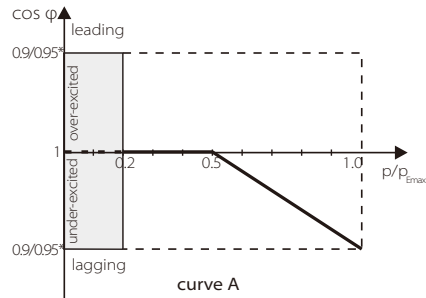

● Reactive power control, reactive power standard curve $Q = f(V)$

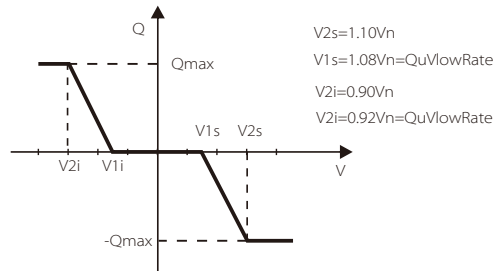

n) DRM function (applied to NZS4777.2)

The DRM function is a demand response method required by the NZS4777.2 standard and is only applicable to NZS4777.2. The default value is "enable". Select "Disable" to disable this function.

DRM Function	
>Function	Control
Enable	Disable

o) Parallel Setting

If a parallel operation is required, the user may set it with Parallel Setting.

Parallel Setting	
> Status	Free
Setting	> Master<

Parallel Setting	
> Status	Free
Setting	Free

o) Main Breaker Limit

For power limit of smart meter or CT, the current must be set in line with the utility's contract requirements. In case of failure to set, it may cause a circuit breaker fault of main switchboard, adversely affecting the charging or discharging of battery. Click Main Breaker Limit to enter the setting interface, and then choose the corresponding amperage according to the utility's requirements.

Main Breaker Limit	
>Current	40 A

q) Battery Heating

If the user needs the battery heating function, you can set it to turn on here, and set the time period that needs to be heated, and the two time periods can be set. (Only for batteries with heating function)

Battery Heating	
>Func Select:	
Enable	Disable

Battery Heating	
>Heating Period 1:	
Start Time	00:00

Battery Heating	
>Heating Period 1:	
End Time	00:00

Battery Heating	
>Heating Period 2:	
Start Time	00:00

Battery Heating	
>Heating Period 2:	
End Time	00:00

r) EPS Setting

Users can set the frequency selection in the EPS mode here, and set the minimum SOC and minimum ESC SOC.
 When the device is in EPS mode, once the battery SOC is lower than the Min SOC of the inverter, it displays "Bat Power Low". If there is PV, the energy of PV will charge the battery. When the SOC of the battery reaches the Min Esc SOC, the inverter will automatically enter EPS mode. The default value of Min Esc SOC is 30% and Min Esc SOC can set between 15% and 100%.

EPS Setting > Frequency 50Hz	EPS Setting >Frequency 60Hz
EPS Setting > Min SoC 10%	EPS auto restart Min ESC SOC 20% for lithium battery

s) Phase Unbalanced

This function controls the distribution of AC output power. "Enable" means each phase will be divided according to the loads connected with each phase. "Disable" means each phase power will be divided equally and "disable" is the default setting value.

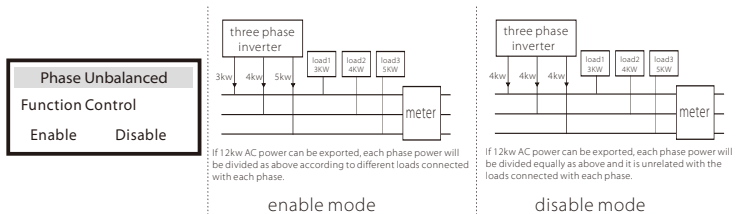

t) AS 4777 Setting

It is the same as the function of Export Control, but it's only applicable to Australia and New Zealand.

AS 4777 Setting > Export Control General Control	Export Control Soft Limit Enable Disable
Export Control Soft Limit Value 300000 W	Export Control Hard Limit Enable Disable
Export Control Hard Limit Value 300000 W	AS 4777 Setting Export Control > General Control

u) Reset

Users can reset the reset error log, meter power, inverter power, and restore factory settings here.

General Control Soft Limit Enable Disable	General Control Soft Limit Value 300000 VA
General Control Hard Limit Enable Disable	General Control Hard Limit Value 300000 VA
Reset Error Log >Reset Yes	Reset Meter/CT >Reset Yes
Reset INV Energy >Reset Yes	Factory Reset >Reset Yes
Reset "Wifi" >Reset Yes	

v) Advance password

Here you can reset the advanced password. "Set OK!" is displayed on success, and "Setup Failed!" Will also displayed on failure.

Advance Password Set OK!	Advance Password Setup failed
------------------------------------	---

w) ExternalGen

Setting path: Advance Setting->ExternalGen->Function Control: Enable/Disable; Max Charge Power: ***W.

The set value of power must meet the following two conditions when the maximum charging power of batteries is to be set.

- 1) The value of Max Charge Power is less than that of rated power of the generator minus total load power.
- 2) The value of Max Charge Power is less than or equals that of rated power of the inverter.

External Gen Function Control Enable Disable	External Gen MaxChargePower 5000W
--	--

x) Pgrid Bias

Here you can set whether to discharge more to the grid or prefer to take power from the grid. If disable is selected, means no preference. If Grid is selected, the inverter will be biased to discharge the mains; if INV is selected, the inverter will be biased to take power from the mains.

Pgrid Bias >Pgrid Bias Disable/Grid/INV
--

➤ About

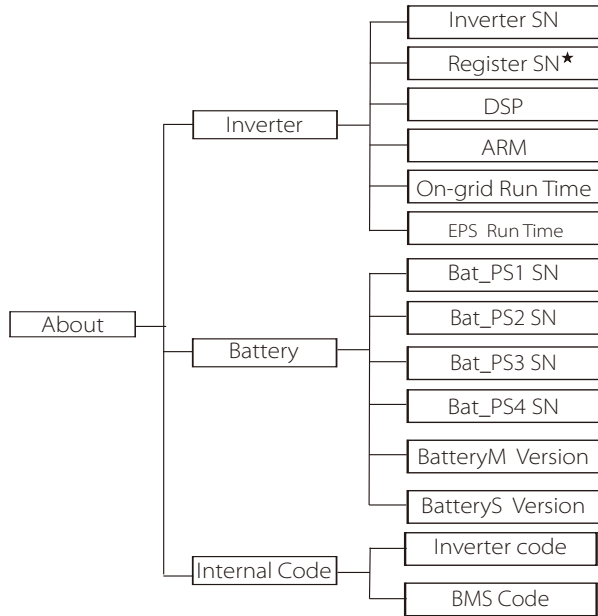

★ Register1 SN: Represents the serial number of external monitoring equipment, such as Pocket WiFi, Pocket LAN.

a) About

Here you can see some basic information of the inverter and battery, such as the inverter and battery SN number, software version number, and system run time.

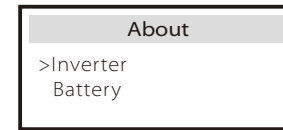

Inverter

Inverter >Inverter SN 01234560123456	Inverter >Register 01234560123456
Inverter >DSP 2.07	Inverter >ARM 1.03
Inverter >EPS(Off-grid) Runtime 20.0H	Inverter >On-grid runtime 45.9H

Battery

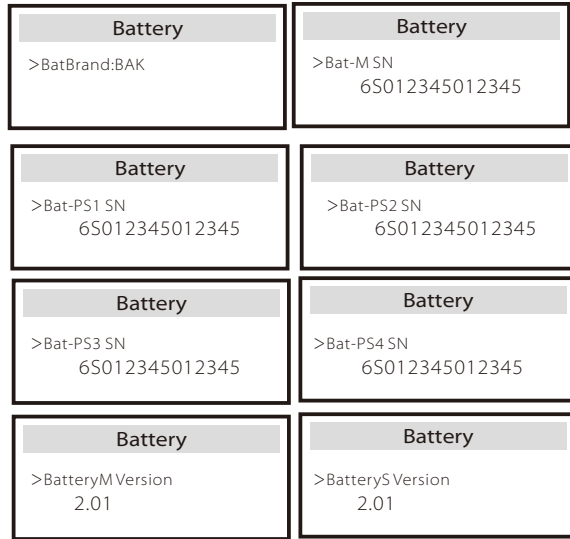

Internal Code

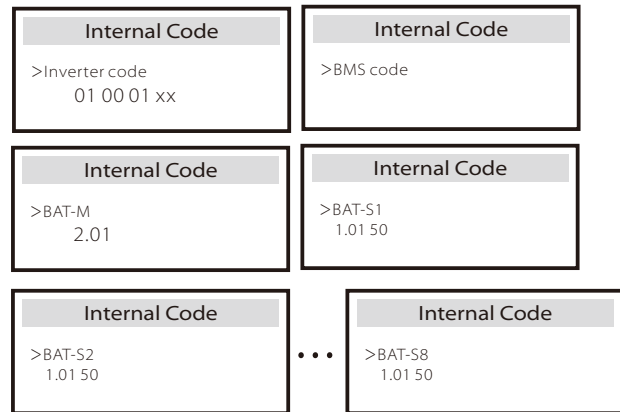

> Information

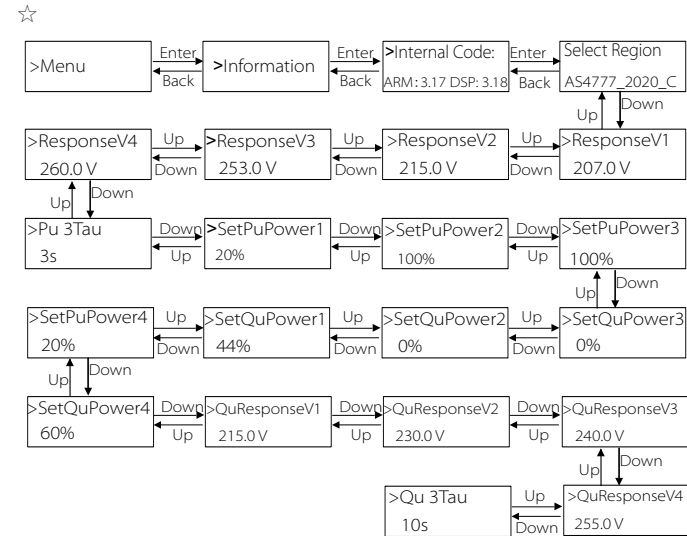

Note!

- Once settings are selected at commissioning they are locked to view only.
- In case of a Path Diagram with the mark of "☆", it indicates that such a Path Diagram is only applicable to Australia and New Zealand.

8 Troubleshooting

8.1 Troubleshooting

This section contains information and procedures for resolving possible problems with the inverter, and provides you with troubleshooting tips to identify and solve most problems that may occur in the inverter. This section will help you narrow down the source of any problems you may encounter. Please read the troubleshooting steps below.

Check the warning or fault information on the system control panel or the fault code on the inverter information panel. If a message is displayed, log it before doing anything further.

Try the solutions indicated in the table below.

Number	Faults	Diagnosis and solution
IE 001	TZ Protect Fault	Overcurrent fault. • Wait for a while to check if you're back to normal. • Disconnect PV+ PV- and batteries, reconnect. • Or ask for help from the installer if it can not return to normal.
IE 002	Grid Lost Fault	• Check battery input voltage if it's within normal range • Or ask the installer for help.
IE 003	Grid Volt Fault	Power grid voltage overrun • Wait a moment, if the utility returns to normal, the system will reconnect. • Please check if the grid voltage is within normal range. • Or ask the installer for help.
IE 004	Grid Freq Fault	Electricity frequency beyond range • If the utility returns to normal, the system reconnects. • Or ask the installer for help.
IE 005	PV Volt Fault	PV voltage out of range • Check the output voltage of the PV panel • Or ask the installer for help.
IE 006	Bus Volt Fault	• press the "ESC" key to restart the inverter. • Check that the PV input open circuit voltage is in the normal range. • Or ask the installer for help.
IE 007	Bat Volt Fault	Battery voltage fault • Check battery input voltage if it's within normal range • Or ask the installer for help.
IE 008	AC10M Volt Fault	• The grid voltage was out of range in the last 10 minutes. • The system will return to normal if the grid returns to normal. • Or ask the installer for help.

Number	Faults	Diagnosis and solution
IE 009	DCI OCP Fault	DCI overcurrent protection fault. • Wait for a while to check if it's back to normal. • Or ask the installer for help.
IE 010	DCV OVP Fault	DCV EPS(Off-grid) overvoltage protection failure. • Wait for a while to check if it's back to normal. • Or ask the installer for help.
IE 011	SW OCP Fault	Software Detection of Overcurrent Fault. • Wait for a while to check if it's back to normal. • Shut down photovoltaic, battery and grid connections • Or ask the installer for help.
IE 012	RC OCP Fault	Overcurrent protection fault. • Check the impedance of DC input and AC output. • Wait for a while to check if it's back to normal. • Or ask the installer for help.
IE 013	Isolation Fault	Insulation Fault • Please check the wire insulation for damage. • Wait for a while to check if it's back to normal. • Or ask the installer for help.
IE 014	Temp Over Fault	Temperature beyond limit • Check if ambient temperature exceeds the limit. • Or ask the installer for help.
IE 015	Bat Con Dir Fault	EPS(Off-grid) mode current is too strong. • Ensure that the load power is within the EPS(Off-grid) power range. • Check for any non-linear load connections on the EPS(Off-grid). • Move this load to check for recovery. • Or ask for help from the installer if it can not return to normal.
IE 016	EPS(Off-grid) Overload Fault	EPS(Off-grid) over load fault. • Shutdown the high-power device and press the "ESC" key to restart the inverter. • Or ask for help from the installer if it can not return to normal.
IE 017	OverLoad Fault	On-grid mode over load • Shutdown the high-power device and press the "ESC" key to restart the inverter. • Or ask for help from the installer if it can not return to normal.
IE 018	BatPowerLow	• Close the high-power device and press the "ESC" key to restart the inverter. • Please charge the battery to a level higher than the protection capacity or protection voltage
IE 019	BMS Lost	Battery communication loss • Check that the communication lines between the battery and the inverter are properly connected. • Or ask for help from the installer if it can not return to normal.
IE 020	Fan Fault	Fan Fault • Check for any foreign matter that may have caused the fan not to function properly. • Or ask for help from the installer if it can not return to normal.
IE 021	Low Temp	Low temperature fault. • Check if the ambient temperature is too low. • Or ask for help from the installer if it can not return to normal.

Number	Faults	Diagnosis and solution
IE 022	ARM Unmatched	ARM software version mismatch Fault <ul style="list-style-type: none"> • update the software and press the ESC" key to restart the inverter. • Or ask for help from the installer if it can not return to normal .
IE 023	Other Device Fault	Other device Fault <ul style="list-style-type: none"> • update the software and press the ESC" key to restart the inverter. • Or ask for help from the installer if it can not return to normal .
IE 025	InterComms Error	Mgr InterCom Fault <ul style="list-style-type: none"> • Shut down photovoltaic, battery and grid, reconnect. • Or ask for help from the installer if it can not return to normal .
IE 025	InterComms Error	<ul style="list-style-type: none"> • Internal communication errors • Shut down photovoltaic, battery and grid connections. • Or ask for help from the installer if it can not return to normal.
IE 026	Inv EEPROM Fault	Inverter EEPROM Fault. <ul style="list-style-type: none"> • Shut down photovoltaic, battery and grid, reconnect. • Or ask for help from the installer if it can not return to normal.
IE 027	RCD Fault	Fault of Residual Current Device <ul style="list-style-type: none"> • Check the impedance of DC input and AC output. • Disconnect PV + PV - and batteries, reconnect. • Or ask for help from the installer if it can not return to normal.
IE 028	Grid Relay Fault	Electrical relay failure <ul style="list-style-type: none"> • Disconnect PV+ ,PV- , grid and batteries and reconnect. • Or ask for help from the installer if it can not return to normal.
IE 029	EPS(Off-grid) Relay Fault	EPS(Off-grid) relay failure <ul style="list-style-type: none"> • Disconnect PV+ ,PV- , grid and batteries and reconnect. • Or ask for help from the installer if it can not return to normal.
IE 030	PV ConnDirFault	PV direction fault <ul style="list-style-type: none"> • Check if the PV input lines are connected in the opposite direction. • Or ask for help from the installer if it can not return to normal.
IE 031	ChargerRelayFault	Charge relay fault <ul style="list-style-type: none"> • Press the ESC" key to restart the inverter. . • Or ask for help from the installer if it can not return to normal.
IE 032	EarthRaleyFault	EPS(Off-grid) earth relay fault <ul style="list-style-type: none"> • Press the ESC" key to restart the inverter. . • Or ask for help from the installer if it can not return to normal.
IE 101	PowerTypeFault	Power type fault <ul style="list-style-type: none"> • Upgrade the software and press the ESC" key to restart the inverter. • Or ask for help from the installer if it can not return to normal.
IE 102	Port OC Warning	EPS(Off-grid) port over current fault <ul style="list-style-type: none"> • Check that the EPS(Off-grid) load does not exceed the system requirements, and press the ESC" key to restart the inverter. . • Or ask for help from the installer if it can not return to normal.

Number	Faults	Diagnosis and solution
IE 103	Mgr EEPROM Fault	Manager EEPROM Fault. <ul style="list-style-type: none"> • Shut down photovoltaic ,battery and grid ,reconnect. • Or seek help from the installer if it can not return to normal.
IE 104	DSPUnmatched	DSP version error. <ul style="list-style-type: none"> • Check that the DSP1 version matches • Or seek help from the installer if it can not return to normal.
IE 105	NTC Sample Invalid	NTC invalid <ul style="list-style-type: none"> • Make sure the NTC is properly connected and the NTC is in good condition. • Please confirm that the installation environment is normal • Or ask for help from the installer, if it can not return to normal.
IE 106	Bat Temp Low	Battery temp low <ul style="list-style-type: none"> • Check the battery installation environment to ensure good heat dissipation. • Or ask for help from the installer, if it can not return to normal.
IE 107	Bat Temp High	Battery temp high <ul style="list-style-type: none"> • Check the battery installation environment to ensure good heat dissipation. • Or ask for help from the installer, if it can not return to normal.
IE 109	Meter Fault	Meter error <ul style="list-style-type: none"> • Please check that the instrument is working properly • Or seek help from the installer if it can not return to normal.
IE 110	BypassRaleyFault	Bypass relay fault <ul style="list-style-type: none"> • Press the ESC" key to restart the inverter. . • Or ask for help from the installer if it can not return to normal.
BE 001	BMS_External_Err	Battery Error - External Communication Fault <ul style="list-style-type: none"> • Please contact the battery supplier.
BE 002	BMS_Internal_Err	Battery Error - Internal Communication Fault <ul style="list-style-type: none"> • Please contact the battery supplier.
BE 003	BMS_OverVoltage	Over voltage in battery system <ul style="list-style-type: none"> • Please contact the battery supplier.
BE 004	BMS_LowerVoltage	Low voltage in battery system <ul style="list-style-type: none"> • Please contact the battery supplier.
BE 005	BMS_ChargeOCP	Battery fault - over charge fault <ul style="list-style-type: none"> • Please contact the battery supplier.
BE 006	BMS_DischargeOCP	Battery fault-discharge over current fault <ul style="list-style-type: none"> • Please contact the battery supplier.
BE 007	BMS_TemHigh	Over temperature in battery system <ul style="list-style-type: none"> • Please contact the battery supplier.
BE 008	BMS_TempSensor Fault	Battery temperature sensor malfunction <ul style="list-style-type: none"> • Please contact the battery supplier.

Number	Faults	Diagnosis and solution
BE 009	BMS_CellImblance	Battery Unbalanced Failure • Please contact the battery supplier.
BE 010	BMS_Hardware Protect	Battery hardware protection failure • Please contact the battery supplier.
BE 011	BMS_Circuit_Fault	Battery circuit failure • Restart the battery . • Please contact the battery supplier.
BE 012	BMS_ISO_Fault	Battery insulation failure • Check that the battery is properly grounded and restart the battery. • Please contact the battery supplier.
BE 013	BMS_VolSen_Fault	Battery voltage sensor fault • Please contact the battery supplier.
BE 014	BMS_TempSen_Fault	Temperature sensor failure • Restart the battery . • Please contact the battery supplier.
BE 015	BMS_CurSensor Fault	Battery current sensor fault • Please contact the battery supplier.
BE 016	BMS_Relay Fault	Battery relay failure • Please contact the battery supplier.
BE 017	BMS_Type_Unmatch	Battery type failure • Upgrade the battery BMS software. • Please contact the battery supplier.
BE 018	BMS_Ver_ Unmatch	Battery version mismatch failure • Upgrade the battery BMS software. • Please contact the battery supplier.
BE 019	BMS_MFR_ Unmatch	Battery manufacturer did not match the fault • Upgrade the battery BMS software. • Please contact the battery supplier.
BE 020	BMS_SW_ Unmatch	Battery hardware and software mismatch failure • Upgrade the battery BMS software. • Please contact the battery supplier.
BE 021	BMS_M&S_ Unmatch	Battery master slave control mismatches • Upgrade the battery BMS software. • Please contact the battery supplier.
BE 022	BMS_CR_ NORespond	Battery charging request does not respond to a fault • Upgrade the battery BMS software. • Please contact the battery supplier.
BE 023	BMS_SW_ Protect	Battery slave software protection failure • Upgrade the battery BMS software. • Please contact the battery supplier.
BE 024	BMS_536_Fault	Battery fault-discharge over current fault • Please contact the battery supplier.
BE 025	BMS_SelfcheckErr	Over temperature in battery system • Please contact the battery supplier.

Number	Faults	Diagnosis and solution
BE 026	BMS_TempdiffErr	Battery temperature sensor malfunction • Please contact the battery supplier.
BE 027	BMS_BreakFault	Battery Unbalanced Failure • Please contact the battery supplier.
BE 028	BMS_Flash_Fault	Battery hardware protection failure • Please contact the battery supplier.
BE 029	BMS_Precharge_Fault	Battery precharge failure • Please contact the battery supplier.
BE 030	BMS_AirSwitch_Fault	Battery air switch failure • Check that the battery breaker is off. • Please contact the battery supplier.

• If the information panel of your inverter does not show the fault light, check the following list to ensure the current installation status, correct operation.

- Is the inverter located in a clean, dry and well-ventilated place?
- Is the DC input circuit breaker open?
- Is the specification and length of the cable adequate?
- Are the input and output connections and wiring in good condition?
- Is the configuration set correct for your particular installation?

Please contact customer service for further assistance. Please be prepared to describe the details of your system installation and provide the inverter serial number.

8.2 Routine Maintenance

Inverter do not require any maintenance or correction in most cases, but if the inverter often loses power due to overheating, this can be attributed to the following reason:

- * heat sink behind the inverter is covered with dirt.
- If necessary, clean the cooling heat sink with a soft dry cloth or brush. Only trained and authorized professionals familiar with safety requirements can perform maintenance and maintenance work.

➤ Safety inspections

Safety checks should be conducted at least every 12 months, please contact the manufacturer to arrange for appropriate training, expertise, and practical experience in performing these tests. (Please note that this action is not covered by warranty). These data should be recorded in the device log. If the equipment is not running properly or any test fails, the equipment must be repaired for details of safety inspections, refer to section 2 of this manual for safety instructions and europe commission instructions.

➤ Regular maintenance

Only qualified people can do the following work. In the process of using frequency converter, the manager should check and maintain the machine regularly. The specific operation is as follows.

1. Check whether the heat sink is covered with dirt, clean the machine and absorb dust if necessary. This work should be performed from time to time.
2. Check whether the frequency converter indicator is normal, check whether the frequency converter button is normal, check whether the frequency converter display is normal. This inspection should be conducted at least every 6 months.
3. Check the input and output lines for damage or aging. This inspection should be conducted at least every 6 months.
4. Cleaning and safety inspection of PV modules should be carried out at least once every 6 months.

9 Decommissioning

9.1 Disassemble the Inverter

- Remove DC input line and AC output line of inverter.
- Wait for at least 5 minutes to power off.
- Remove all cable connections from the inverter.
- Remove inverter from finger support the bracket.
- Remove the bracket if necessary.

9.2 Packing

Load the inverter into the original package if possible.

- If the original package can not be found, you can also use the following requirements of the carton packaging:
Bearing capacity of more than 30 kg.
Easy to carry.
Can completely seal the cover.

9.3 Storage and Transportation

Store the inverter in a dry, temperature -40°C~70°C environment. Pay attention to less than four machines on each stack board during storage and transportation.

9.4 Waste Disposal

If it is necessary to scrap the inverter or other related parts, be sure to send the waste inverter and packaging materials to the designated location for recycling by the relevant department.

10 Disclaimer

The hybrid inverters are transported, used and operated under limited condition, such as environmental, electrical etc. Our company shall not be liable to provide the service, technical support or compensation under conditions listed below, including but not limited to :

- Inverter is damaged or broken by force majeure (such as earthquake, flooding, thunderstorm, lightning, fire hazard, volcanic eruption etc).
- Inverter's warranty is expired and doesn't buy extended warranty.
- Can't provide the inverter's SN, warranty card or invoice.
- Inverter is damaged by man-made cause. Inverter is used or operated against any items in local policy.
- Inverter's installation, configuration, commissioning doesn't follow the requirements mentioned in this manual.
- Inverter is installed, refitted or operated in improper ways mentioned in this manual without authority from us.
- Inverter is installed, operated under improper environment or electrical condition mentioned in this manual without authority from us.
- Inverter is changed, updated or disassembled on hardware or software without authority from us.
- Obtain the communication protocol from other illegal channels.
- Build monitoring, control system without authority from us.
- Connect to other brands batteries without authority from us.
- Our company will keep right to explain all the contents in this user manual.

Warranty Registration Form



For Customer (Compulsory)

Name Country
Phone Number Email
Address
State Zip Code
Product Serial Number
Date of Commissioning
Installation Company Name
Installer Name Electrician License No.

For Installer

Module (If Any)

Module Brand
Module Size(W)
Number of String Number of Panel Per String

Battery (If Any)

Battery Type
Brand
Number of Battery Attached
Date of Delivery Signature

Please visit our warranty website: <https://www.solaxcloud.com/#/warranty> to complete the online warranty registration or use your mobile phone to scan the QR code to register.

For more detailed warranty terms, please visit SolaX official website: www.solaxpower.com to check it.





PLEASE REGISTER THE WARRANTY IMMEDIATELY AFTER INSTALLATION! GET YOUR WARRANTY CERTIFICATE FROM DURACELL! KEEP YOUR INVERTER ONLINE & WIN DURACELL POINTS!

1

Open your camera app and point your device at the QR code



2

Wait for the camera to recognize the QR code



3

Click banner or notification when it appears on the screen



4

Warranty registration page will be loaded automatically

