



# Liquid-Cooled Energy Storage Cabinet

## User Manual

ASW 125K/261-PT

# Preface

## Summary

The ASW 125K/261-PT series is a lithium iron phosphate (LFP) battery integrated system specifically designed for energy storage applications (hereafter referred to as "Energy Storage Integrated Cabinet"). This all-in-one solution combines energy storage converters, batteries, Battery Management System (BMS), Energy Management System (EMS), thermal management, and fire protection functions, making installation and maintenance more convenient. The system demonstrates significant advantages in safety, extended cycle life, high energy density, fast charging capabilities, wide operating temperature range, and environmental sustainability.

This manual provides detailed instructions for the ASW 125K/261-PT series energy storage cabinets, covering essential features and operational procedures. It includes comprehensive guidance on installation, parameter configuration, field commissioning, troubleshooting, as well as daily maintenance protocols. Before installing or using the system, please read this manual carefully. Only after fully understanding the safety precautions and system functionalities should you proceed with installation.

If in doubt, please contact the manufacturer immediately for advice and clarification.

## Warranty statement

Under normal use, the product is faulty or damaged, and the manufacturer will provide warranty service within the warranty period (see the order for details of the warranty period). After the warranty period, the maintenance fee will be charged.

During the warranty period, repair costs will be charged for product damage caused by the following circumstances.

- Failure to operate the product according to the provisions in the manual, resulting in damage to the product.
- Fire, flood, abnormal voltage, resulting in product damage.
- Using this product for abnormal functions, resulting in product damage.
- Damage to products caused by exceeding the scope of use specified in the product.
- Secondary damage to products caused by force majeure (natural disasters, earthquakes, lightning strikes).

The service fee shall be calculated according to the unified standard of the manufacturer. If there is a contract, the principle of contract priority shall be followed.

## Table of contents

<b>Preface</b> .....	<b>2</b>
<b>1 Safety Notes</b> .....	<b>1</b>
1.1 Security statement .....	1
1.2 Operator requirements .....	1
1.3 Safety warning symbols guide.....	1
1.4 Security matters .....	1
<b>2 On-product information</b> .....	<b>3</b>
2.1 System survey .....	3
2.2 Visual presentation .....	4
2.3 Component introduction .....	5
2.4 Product Specifications.....	6
2.5 Main components .....	7
2.6 Fire extinguisher system .....	17
2.7 Battery management system BMS.....	19
<b>3 Site selection and relocation</b> .....	<b>21</b>
3.1 Site selection requirements .....	21
3.2 Installation preparation .....	23
3.3 Goods received inspection.....	25
3.4 Storage precautions .....	25
3.5 Carry.....	25
3.6 Packaging disassembly instructions .....	27
<b>4 Electrical installation</b> .....	<b>31</b>
4.1 Safety tips.....	31
4.2 Electrical connections .....	31
4.3 Check after wiring .....	42
<b>5 Power on and power off the energy storage cabinet</b> .....	<b>43</b>
5.1 Pre-electrification inspection .....	43
5.2 Powering the energy storage cabinet .....	43
5.3 Power down the energy storage cabinet .....	44
5.4 On/Off-grid switching .....	45
<b>6 EMS operation declaration</b> .....	<b>55</b>
6.1 Summary - Station Overview .....	55
6.2 Monitoring - Station (QEMS3.0).....	56
6.3 Station end HMI usage instructions .....	80
<b>7 Fault treatment</b> .....	<b>102</b>
<b>8 Daily care and maintenance</b> .....	<b>107</b>
8.1 Daily inspection items .....	107
8.2 Periodic inspection projects .....	108
<b>9 Operations content</b> .....	<b>109</b>
9.1 Battery cluster operations .....	109
9.2 Battery management system operation and maintenance .....	111
9.3 Fire system operation and maintenance .....	113

9.4 Hot system management and operation ..... 113

**10 Processing specification .....116**

**11 Warranty policy or description.....117**

**12 After-sale service .....118**

**13 Contact.....119**

# 1 Safety Notes

## 1.1 Security statement

- This chapter describes the safety precautions that should be paid attention to when using this product correctly. Before using this product, please read the instruction manual and understand the relevant information of safety precautions correctly. Failure to comply with the safety precautions may result in death, serious injury or damage to equipment.
- The "danger", "warning" and "note" matters in the manual do not represent all the safety matters that should be observed, but only as a supplement to all the safety matters.
- This product should be used in accordance with the design specifications, otherwise it may cause failure. The functional abnormalities or component damage caused by non-compliance with relevant regulations are not within the scope of product quality assurance.
- Our company will not be liable for personal safety accidents and property losses caused by non-compliance with the contents of this book and illegal operation of products.

## 1.2 Operator requirements

Operators must have the following skills:

- Training in installation and commissioning of electrical systems and handling of hazards;
- Understand this manual and other relevant documents;
- Understand local laws and regulations.

## 1.3 Safety warning symbols guide

### DANGER

Indicates that failure to follow the rules results in death or serious bodily harm.

### WARNING

Indicates that failure to follow the instructions may result in death or serious bodily injury.

### CAUTION

Indicates that failure to follow the instructions may result in minor physical injury or equipment damage and shortened life cycle.

## 1.4 Security matters

The illustrations of the products in this specification sometimes show the products in the state of being removed from the cover or safety cover to show the details of the products. When using the products, please be sure to install the cover or cover as required and operate according to the instructions.

The product diagram in this manual is only an example, and may be slightly different from the product you order. Please order the actual product.

## **DANGER**

Battery strings can produce high-voltage direct current power and can lead to fatal voltage and electric shock.

- Only professionals with electrical equipment related training and electrical knowledge can operate. Non-professionals are strictly prohibited from operating!
- Batteries provide electricity, and short circuits or incorrect installation can lead to burns or fire hazards.
- There is a fatal voltage in the battery terminals and cables. Touching the cables and terminals may cause serious injury or death.

## **WARNING**

Battery system damage is a risk of personal injury. Do not unplug the connector while the system is running!

Non-professionals are strictly prohibited from equipment installation, wiring, maintenance, inspection or component replacement!

- Do not carry out equipment maintenance under the condition of power on, otherwise there is a danger of electric shock!
- Before contact the cable connection terminal or electrical device, please measure whether there is voltage, ensure that the cable connection terminal or device is under no voltage or safe voltage, otherwise there may be a danger of electric shock!
- Do not open or deform the battery module, otherwise the product will be outside the warranty.
- Whenever batteries are used, wear appropriate personal protective equipment such as insulating clothing, rubber boots, goggles, safety helmets and rubber gloves.
- ASW 125K/261-PT system operating temperature range:  $-25^{\circ}\text{C}\sim 55^{\circ}\text{C}$ ; optimal temperature:  $18^{\circ}\text{C}\sim 28^{\circ}\text{C}$ . Exceeding the operating temperature range may cause the battery system to overheat/low temperature alarm or protection, which can further lead to reduced cycle life and will also affect warranty terms.

## **CAUTION**

Improper setup or maintenance can permanently damage the battery.

Incorrect inverter parameters will lead to further battery failure/damage.

## 2 On-product information

### 2.1 System survey

The system works as follows.

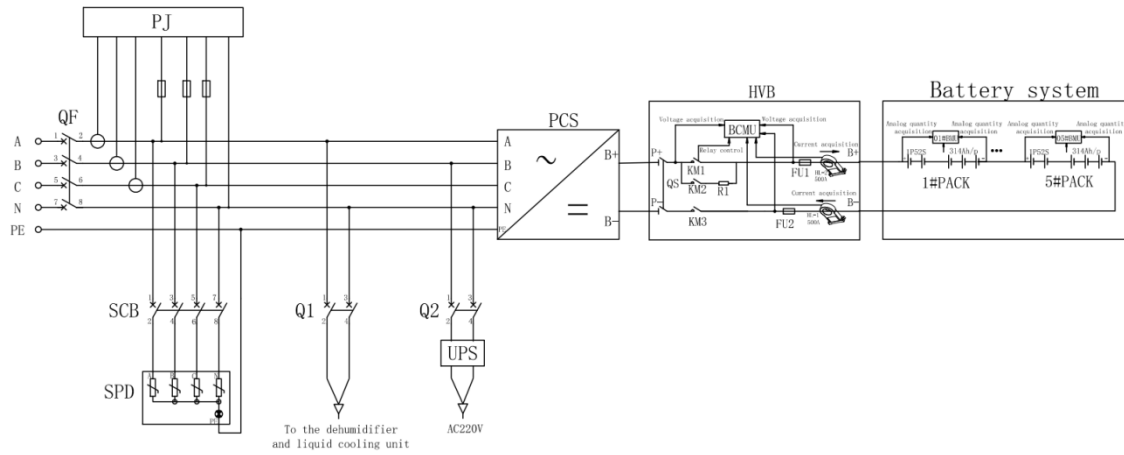

Fig. 1. Primary system diagram

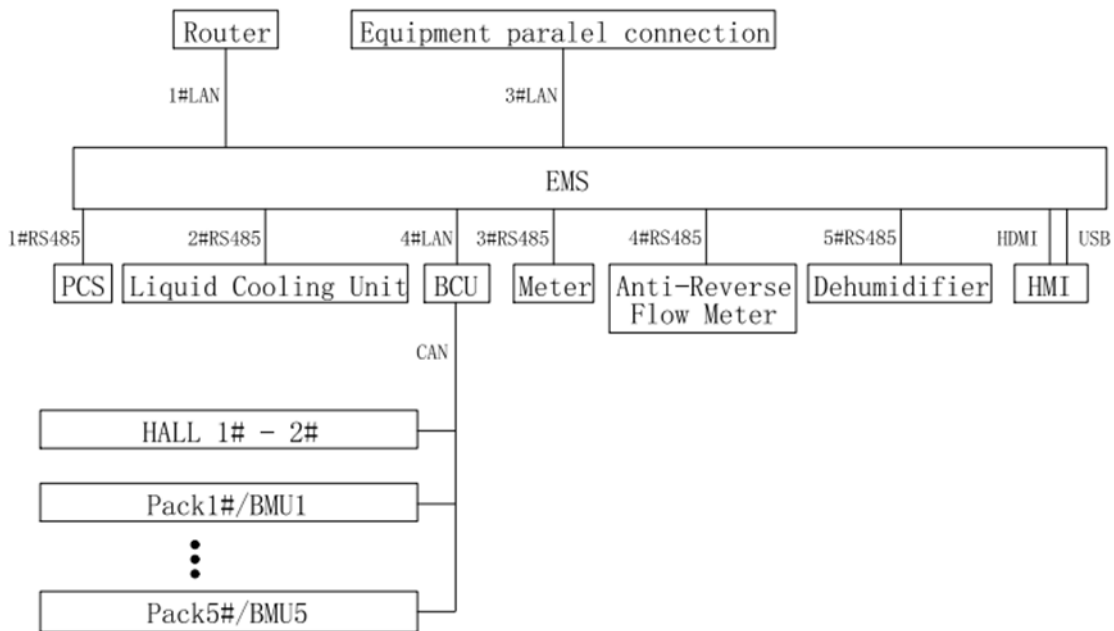

Fig. 2. System communication topology

## 2.2 Visual presentation

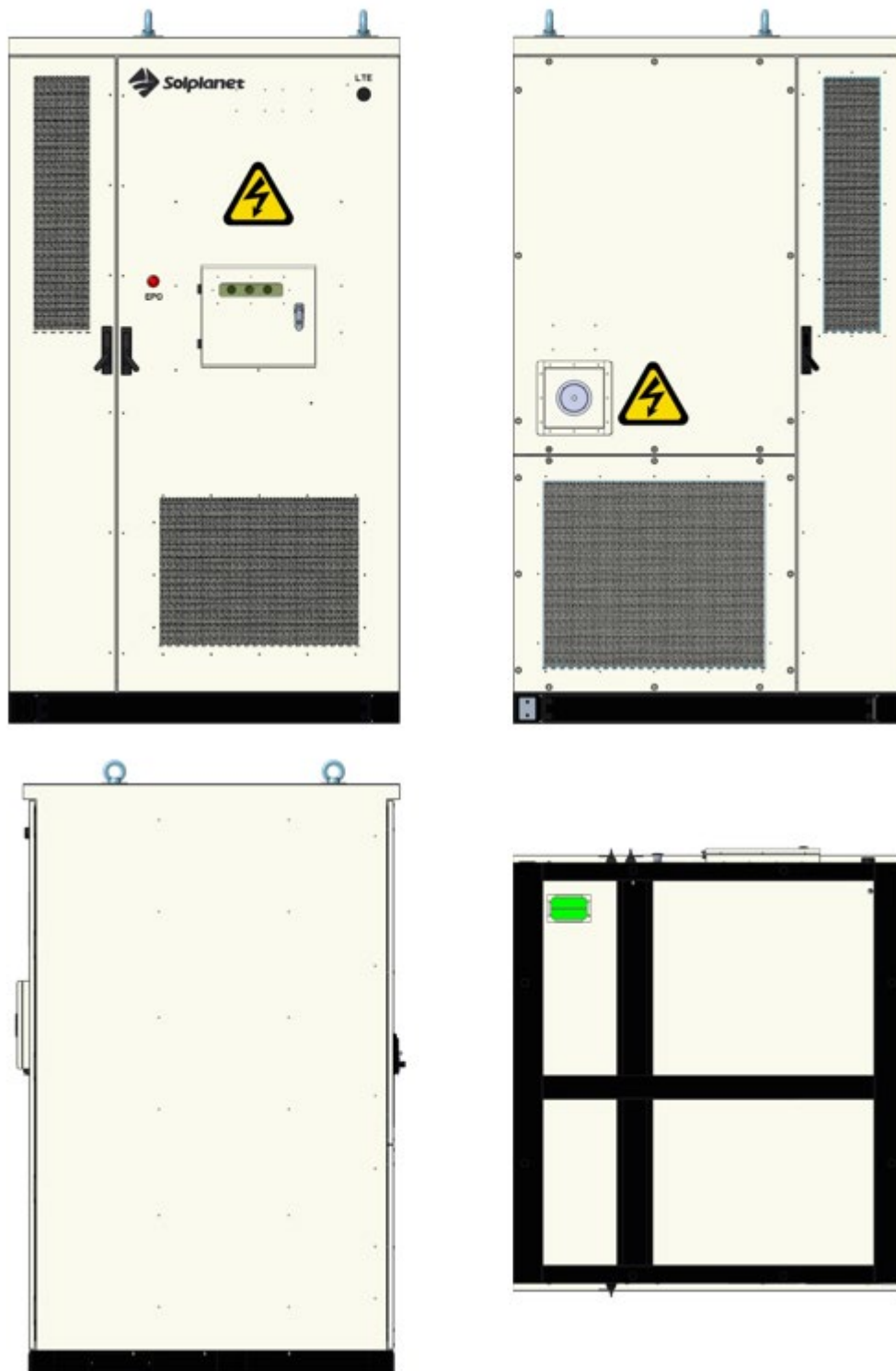

Fig. 3. Appearance Introduction Figure

## 2.3 Component introduction

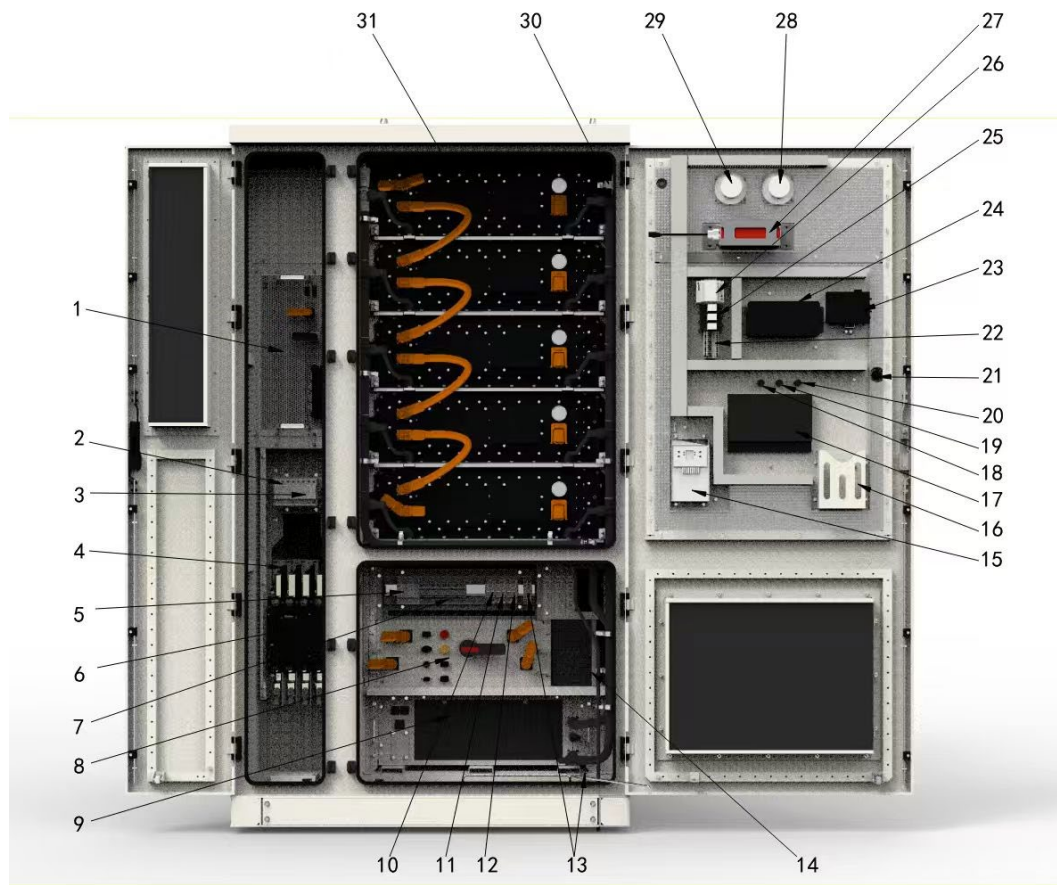

Fig. 4. Schematic diagram of internal components of the cabinet

NO.	Name	Explain	Remarks
1	PCS	Energy storage converter	/
2	SPD	Lightning arresters	/
3	SCB	Lightning protection	/
4	CT	Current transformer	/
5	PJ	Any meter for measuring electricity	/
6	QF	Power grid switches	/
7	XT1~XT3	Terminal board	/
8	HVB	High-voltage compartment	/
9	LJ	Liquid cooling unit	/
10	Q1	Cold machine switch	/
11	Q2	UPS entry switch	/
12	Q3	UPS out switch	/
13	SJ	Water sensor	/
14	UPS	Back up power	/

15	CSJ	Dehumidifier	/
16	Document box	Documentation available	/
17	HMI	Display screen	/
18	HR	Fault indicating lamp	/
19	HG	Running indicator light	/
20	HY	Alarm indicator	/
21	SB	Scram button	/
22	XT4	Terminal board	/
23	LYQ	Touter	/
24	EMS	Control module	/
25	KA1~KA3	Electric relay	/
26	DR	Switching Mode Power Supply	/
27	AFC	Aerosol	/
28	TL	Thalposis	/
29	SL	Smoke sense	/
30	SA	Entrance guard	/
31	Pack	Battery pack	/

## 2.4 Product Specifications

Battery parameters	
Battery type	lithium iron phosphate
Cell capacity	3.2V/314Ah
Stringing method	1P260S
PACK quantity	5
Rated energy	261kWh
Rated voltage	832V
Voltage range	728~936V
Charge discharge ratio	≤0.5P
Communication interface	CAN、RS485、ETH
AC parameters	
Rated voltage	380/400V (±15%)
Frequency range	50Hz/60Hz

Power rating	125kW
Maximum output	137.5kW
Maximum output current	200A
Overload capacity	110% long-term
Power factor	-1~1 advance or lag (adjustable)
Current total harmonic distortion	<2% (rated power)
Communication access mode	Three phase four wire
DC component of current	<0.5%
<b>System Parameter</b>	
Operating ambient temperature	-25°C ~ +55°C (> 45°C reduction)
Storage environment temperature	-20°C ~ +45°C (short term) 0°C ~ +35°C (long term)
Relative humidity	0~95%, no condensation
Maximum working altitude	Below 4000m, reduced use above 2000m
Cooling-down method	liquid cooling
System efficiency value	90%
Fire extinguisher system	Aerosol + smoke sensor + temperature sensor (cluster fire)
Size (W*D*H)	1300*1400*2350 (mm)
Weight	About 2.8t
Levels of protection	IP55
Corrosion resistance rating	C4
Communication mode	Ethernet, RS485, CAN, 4G
Network	Support local broadband and 4G service (recommended data package ≥2G)

## 2.5 Main components

### 2.5.1 Battery modules

The LED indicator can indicate the operation state of the inverter. The battery module consists of 52 lithium iron phosphate cells arranged in a 1P52S configuration. Each module contains two 1P26S dual-cell stacks connected in series to form 166.4V314Ah, delivering total energy 52.24kWh. This design features high energy density, a wide operating temperature range, extended lifespan, lightweight construction, and enhanced safety.

The specific battery module parameters are shown in Table.

Battery module parameters

Parameter	Specifications	Remarks
Burst mode	1P52S	/
Nominal capacity	314Ah	25±2℃, 0.5P
Rated energy	52.24kWh	25±2℃, 0.5P
Nominal voltage	166.4V	25±2℃, 0.5P
Working voltage range	145.6V~187.2V	25±2℃, 0.5P
Size (W×D×H)	770×1130×245mm	/
Weight	≈366kg	N.A
Rated charge/discharge ratio	0.5P	25±2℃
Cooling-down method	liqukd cooling	/
Levels of protection	IP66	/
Operating temperature range	-25℃~55℃	discharge
	0℃~55℃	charge
Storage ambient temperature	-20℃~45℃	short-term
	0℃~35℃	over a long period of time

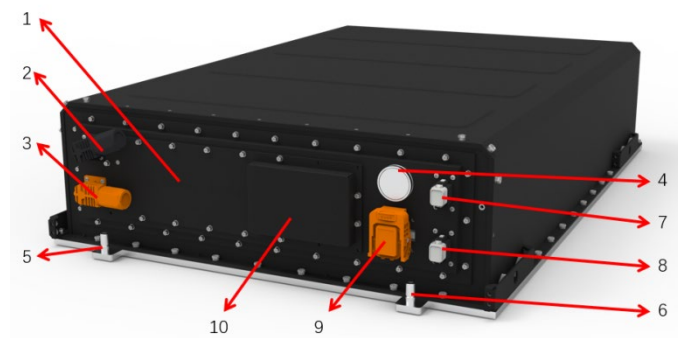

Fig. 5. Battery module panel

No.	Name	Explain	Remarks
1	BMU	Control module	/
2	B+	Battery box positive electrode	/
3	B-	Battery box power negative electrode	/
4	Atmospheric valve	Release gas	/
5	Inlets and outlets	Water intake and discharge	/
6	Inlets and outlets	Water intake and discharge	/
7	COM1	Communication power interface	/

8	COM2	Communication power interface	/
9	MSD	Maintenance switch	/
10	FU	Fuse	/

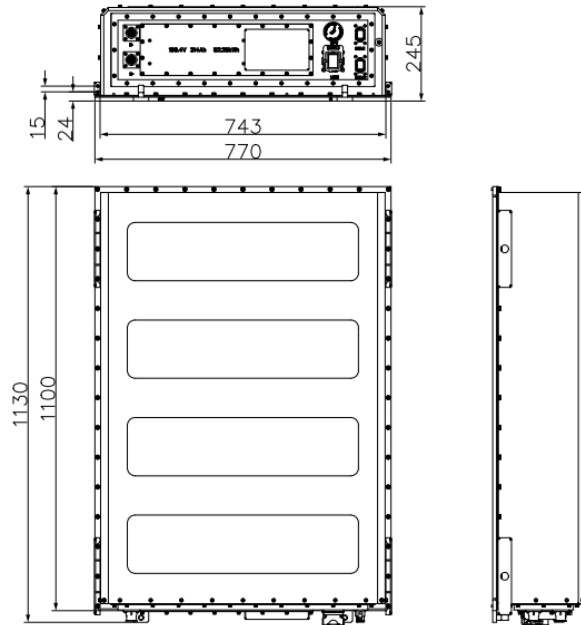

Fig. 6. Battery module size diagram

## 2.5.2 Power Conversion System (PCS)

The main function of energy storage converter system is to realize the electric energy conversion between power grid and battery, and to monitor and manage the exchange process. The specific parameters are shown in table

DC parameters	
Working voltage range	650~950Vdc
Full voltage range	680V~950V
Maximum current	203A
AC parameters	
Range of nominal tension	380/400 (-15%~+15%) Vac
Rated frequency	50/60Hz
Mode of connection	Three phase four wire
Power rating	125kW
Maximum power	137.5kW
Maximum current	200A

Power factor	$\geq 0.99/-1$
Current distortion rate	Less than 2% (rated power)
Direct component	$< 0.5\%$
Overload capacity	110% long-term
Maximal efficiency	$\geq 98.5\%$
<b>Conventional parameters</b>	
Size (width * height * depth)	520*232*785mm
Weight	66.5kg
Above sea level	4000m(reduced when> 2000m)
Working temperature	-30℃ ~55℃ (decrease in use when>45℃)
Humidity	0~95%RH (no condensation)
Cooling-down method	Smart air cooling
Levels of protection	IP20
Communication mode	RS485, Ethernet, CAN

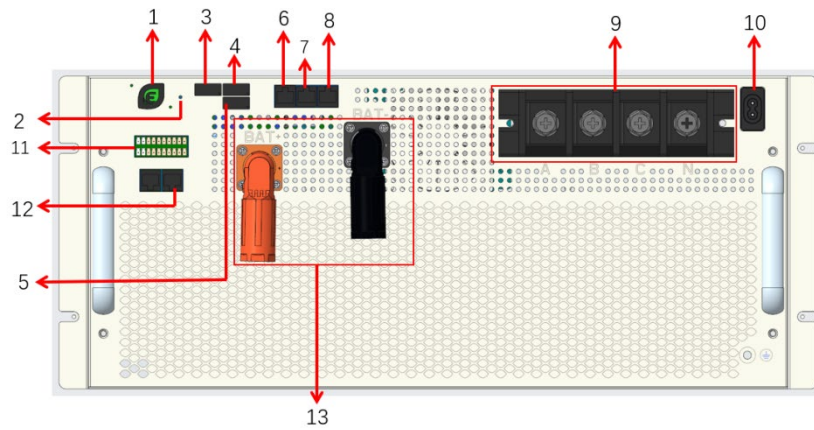

Fig. 7. PCS terminal description Figure

Position	Name	Function	Remarks
1	Pilot lamp	<p>Run the output power and light up the green light;</p> <p>When standby (0kW operation), the green light flashes for 0.5s;</p> <p>When the machine is not turned on and there is no fault, the green light flashes slowly for 1s;</p> <p>The red light stays on for a long time.</p>	/

2	BT	Bluetooth indicator light; The Bluetooth connection is successful and the blue light is on.	/
3	USB	Reserve USB port for software/configuration file upgrade	/
4	ADDR	The fourth bit of the mod address setting (binary) is the lowest bit (from right to left)	/
5	120 Ω	4-bit binary switch. 1.ARM_CAN1 Reserve CAN communication matching resistor, set it up to connect 120 Ω matching resistor; 2.ARM_CAN2 Reserve CAN communication matching resistor, set it up to connect 120 Ω matching resistor; 3.DSP_CAN1 PCS parallel communication matching resistor, the upper tap is connected to 120 Ω matching resistor (CAN_1 in PARA1/PARA2); 4.DSP_CAN2 CAN communication matching resistor, up to the 120 Ω matching resistor (CAN_2 in the Phoenix terminal).	/
6	ETH	Ethernet port, supports ModBus TCP protocol, can be connected to EMS or switch	/
7	COMM3	obligate	/
8	TEST	1/2: DRM0 (reserved); 3~7: Debug communication port in the background (dedicated to debugging)	/
9	Communication interface	Communication end wiring	/
10	Debug power interface	220V AC power input (for debugging)	/
11	Phoenix terminals	External communication signal port.	/
12	PARA	Used for PCS stand-by or PCS/STS communication.	/
13	DC power port	DC side power connector.	/

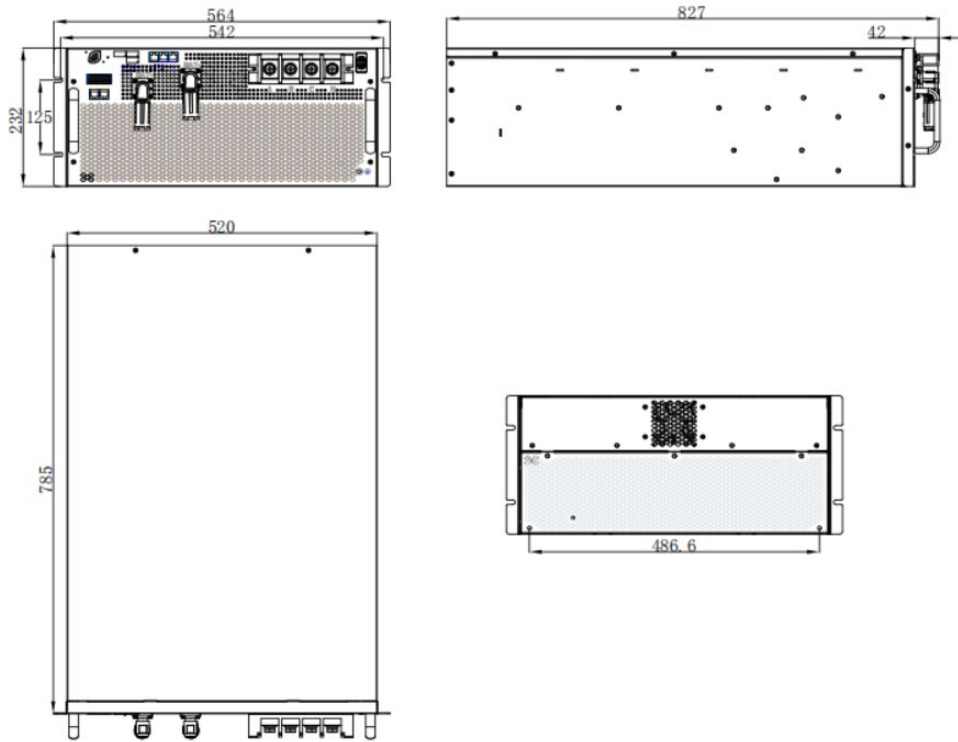

Fig. 8. PCS size diagram

### 2.5.3 High-voltage box (HVB)

The high voltage box of the battery cluster is carefully designed according to the number of connected battery modules, with control devices, fuses and obvious break points, and has functions such as fault protection and safety protection to ensure the electrical safety of the battery.

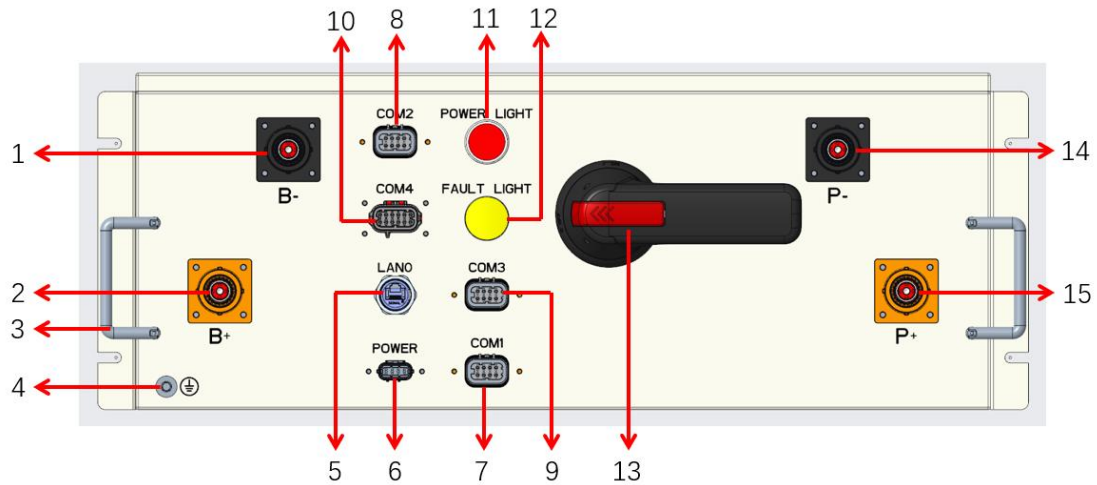

Fig. 9. HVB panel

No.	Name	Function	Remarks
1	B-	Battery cluster negative power port	/
2	B+	Battery cluster positive power port	/
3	handle	High pressure box handle	/

4	ground point	ground point	/
5	LAN0	Display Controls Communications	/
6	POWER	220V power input port	/
7	COM1	Display control communication, automatic addressing	/
8	COM2	Battery cluster communication power port	/
9	COM3	Debug port, PCS communication port	/
10	COM4	Fire, emergency stop, indicator light port	/
11	POWER LIGHT	power light	/
12	FAULT LIGHT	fault indicating lamp	/
13	Battery cluster switch	Battery cluster switch	/
14	P-	PCS anode power port	/
15	P+	PCS positive power port	/

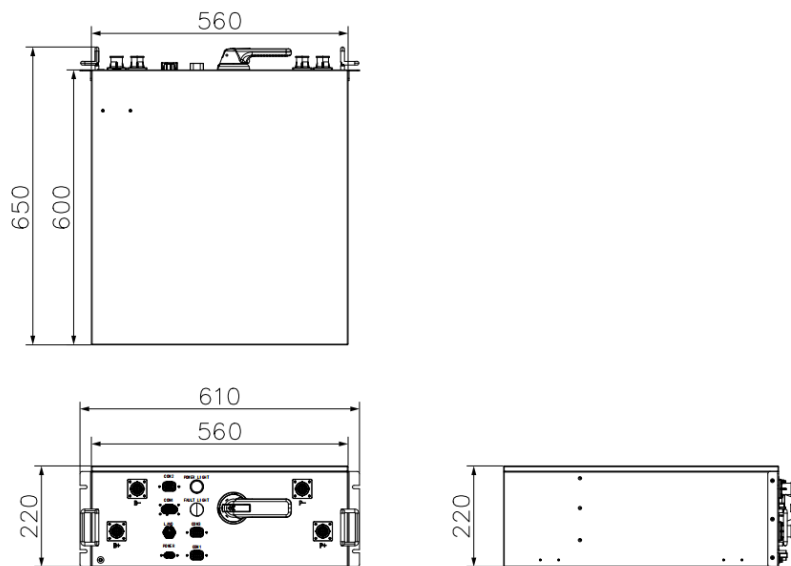

Fig. 10. HVB dimensions

#### 2.5.4 Liquid cooling unit

The liquid cooling unit controller monitors the inlet and outlet water temperature in real time, and makes intelligent adjustment according to the temperature setting, so that the working temperature of the battery in the energy storage cabinet is stable within an appropriate range.

Size, interface form	
External dimensions (width × depth × height) (mm)	700×900×245
Net weight (kg)	75
Way to install	drawer type
Application environment	Outdoor type

Type of inlet and outlet pipe interface	DN20 quick connector
<b>Service environment</b>	
Working environment temperature (°C)	-30~+55
Storage ambient temperature (°C)	-40~+70
Storage humidity range	5%~95%
Noise grade (dB)	74
Corrosion resistance rating	C4
Color of equipment appearance	RAL7035
IP levels of protection	IPX5
Cryogen	R134a
Coolant	50% ethylene glycol aqueous solution
ROHS attestation	yes
Design life (years)	>10
<b>Refrigeration/heating capacity</b>	
Refrigeration capacity @L45/W18 (kW)	3
Heating capacity (kW)	2
Water temperature (°C)	18
<b>Parameter setting</b>	
Liquid temperature setting range (°C)	10~35
Default refrigeration setting temperature (°C)	18
Default heating set temperature (°C)	15
Communication mode	RS485、CAN
<b>Circulating water flow</b>	
Rated circulating water flow (L/min)	30
Rated external circulation head (kPa)	60
<b>Consumed power</b>	
Refrigeration input power @L45/W18 (kW)	1.5
Thermal input power (kW)	2.2
Self-circulation mode (single pump operation) power (kW)	0.1
Maximum power consumption (kW)	2.34
<b>Power form</b>	

Rated working voltage (V,HZ)	220V~240V/50/60HZ
Supported voltage range (V,HZ)	220±15%, 50/60±3HZ
Maximum working current (A)	12.5

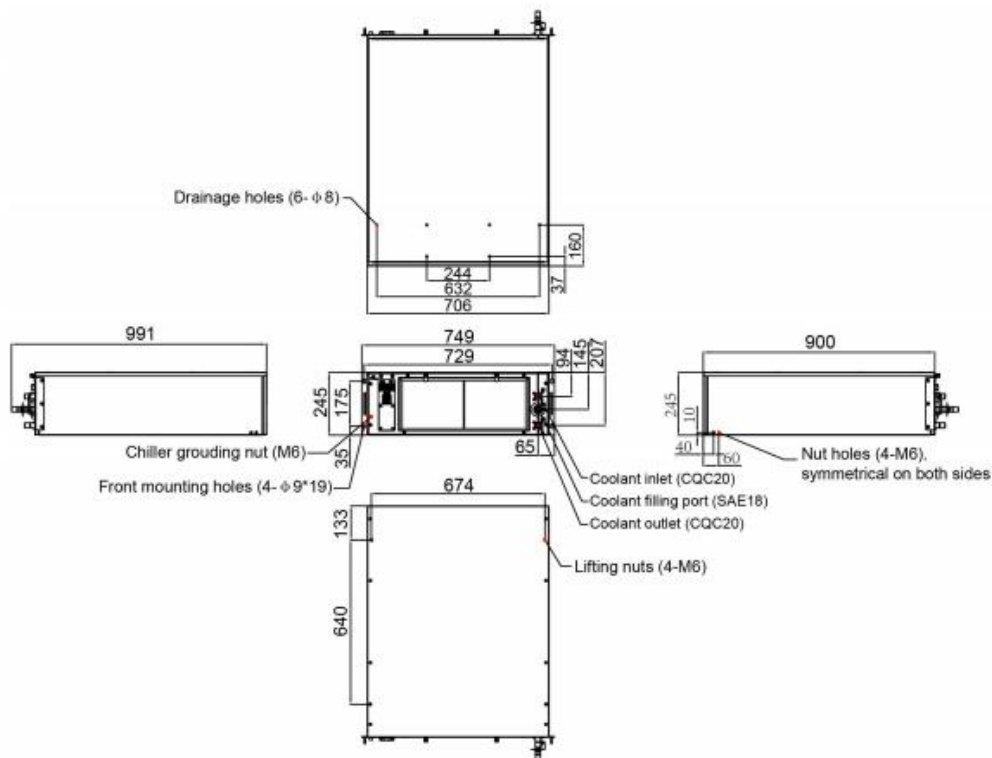

Fig. 11. Liquid cooling unit size diagram

## 2.5.5 The built-in battery module is connected to the cable

### 2.5.5.1 Power line installation

Connect each battery using DC power cables to ensure correct polarity. Connect the first and last battery modules to the B+ and B- terminals of the high-voltage box using DC cables, making sure to reverse the polarity connections. Connect the PCS AC output interface to the A/B/C copper busbars and the N/PE copper busbars using AC power cables. Follow the diagram shown below for complete wiring.

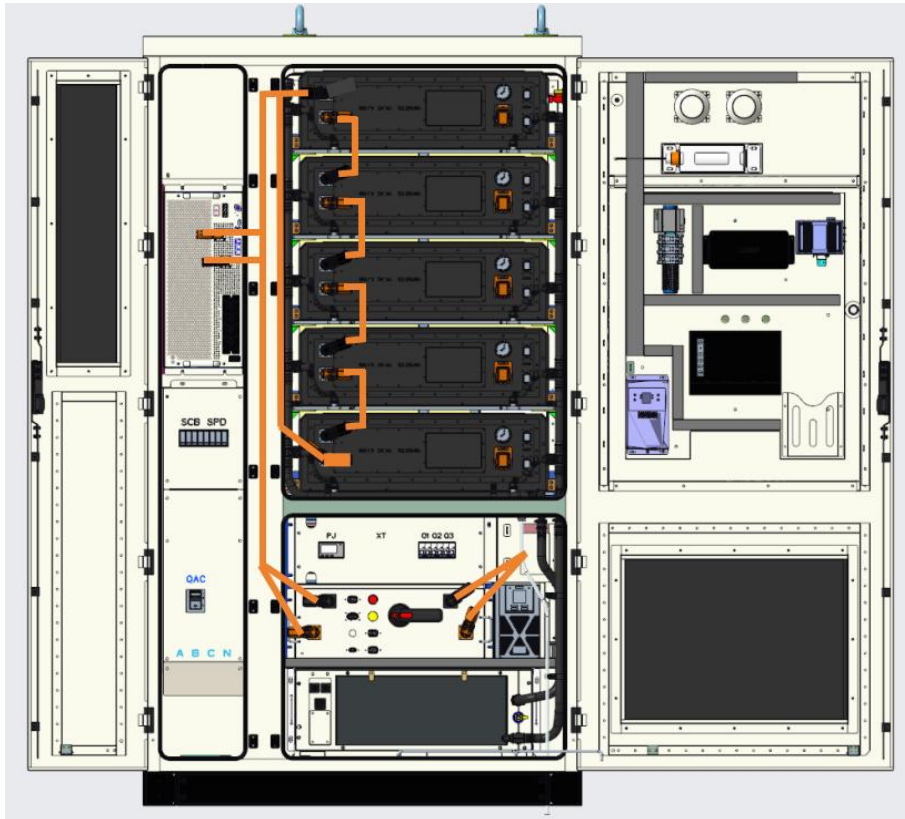

Fig. 12. Power line connection diagram

### 2.5.5.2 Communication cable installation

Connect the BMM communication ports sequentially. Ensure the COM2 port of one battery module connects to the COM1 port of another module. The COM2 port of the first module should be connected to the HVB's BMM port. The final COM1 connector of the battery module must be matched with a resistor. The connection diagram is shown below. (Pre-installed before delivery)

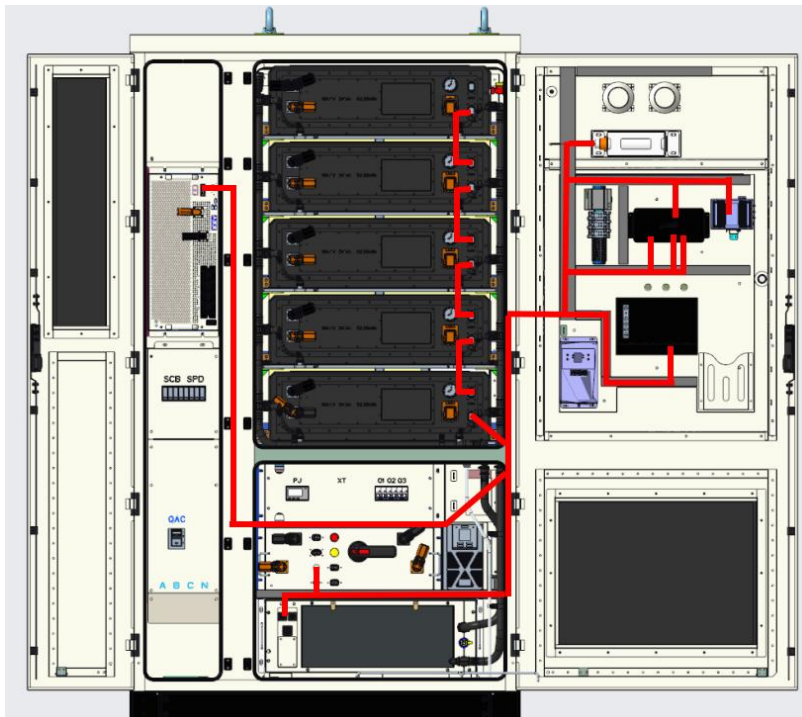
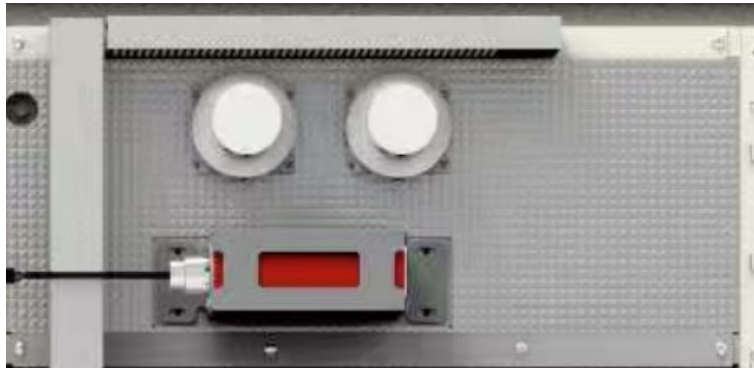

Fig. 13. Communication line connection diagram

## 2.6 Fire extinguisher system



*Fig. 14. Fire protection system installation diagram*

### 2.6.1 Statement

Please comply with the fire laws and regulations of the country or region where you are staying;

Fire control facilities should be checked and maintained regularly to ensure normal fire control functions.

### 2.6.2 Summary

The fire control system consists of aerosol, smoke detector and temperature detector.

The fire fighting system integrates detection, multi-level early warning, fire fighting, information linkage, intelligent start and other functions.

The cabinet is equipped with detectors, including smoke detection, temperature detection and so on.

### 2.6.3 Fire fighting system (aerosol)

The fire protection system for energy storage cabinets is installed within the cabinet body, featuring aerosol fire suppression devices, smoke detectors, and heat detectors. A primary fire alarm signal with external audio-visual alarms is reserved. When a fire occurs due to thermal runaway in battery cells or short circuits in electronic components, the smoke detector detects the fire and triggers a primary alarm signal, activating the audio-visual alarms to alert personnel to take action. If both smoke and heat detectors simultaneously detect a fire, a secondary alarm signal is issued, triggering the aerosol fire suppression system to extinguish the flames while sending fire alarms and fault dry contact signals to the backend control unit.

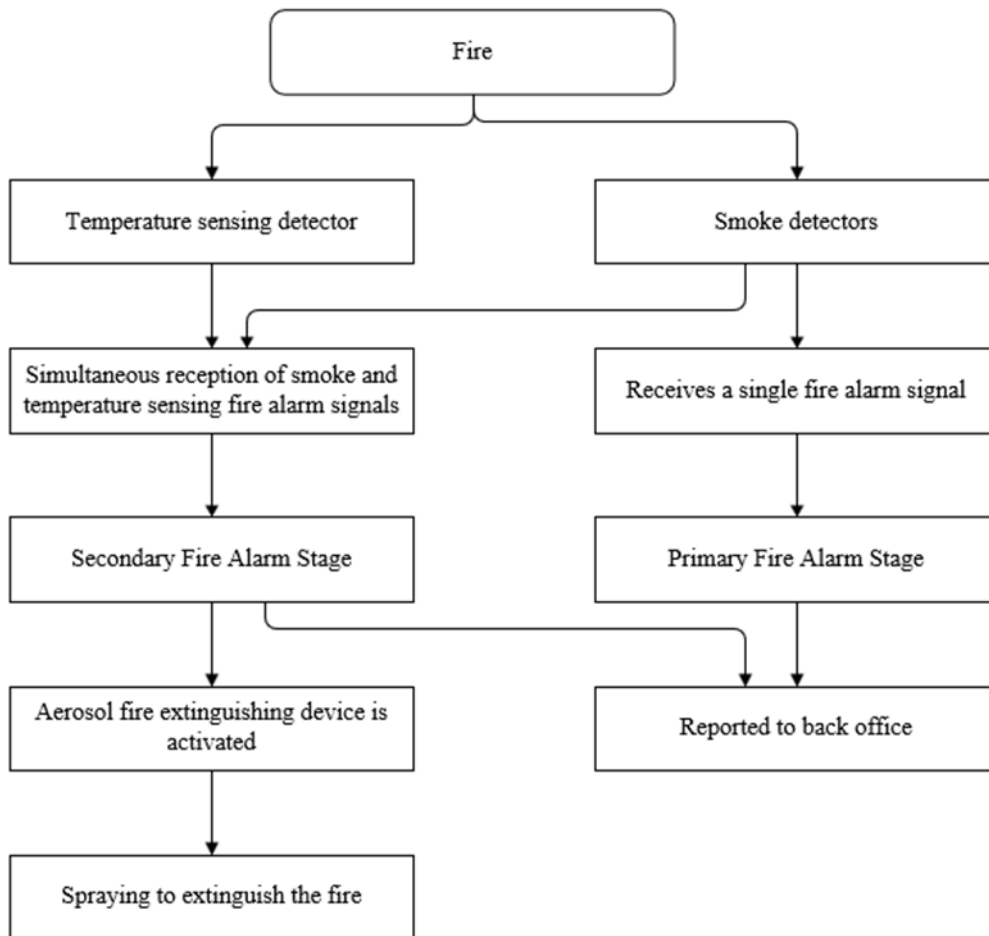

Fig. 15. Fire protection system logic diagram

#### 2.6.4 Fire fighting system (water fire fighting)

The water fire interface of the energy storage cabinet is installed on the back panel, featuring a DN65 German standard water connection (model KA81-G2 1/2" F) compliant with European standards DIN14334 and DIN14335. External water fire pipes are to be installed by the client. When aerosol fire cannot be contained, technicians may activate the external water valve for firefighting purposes.

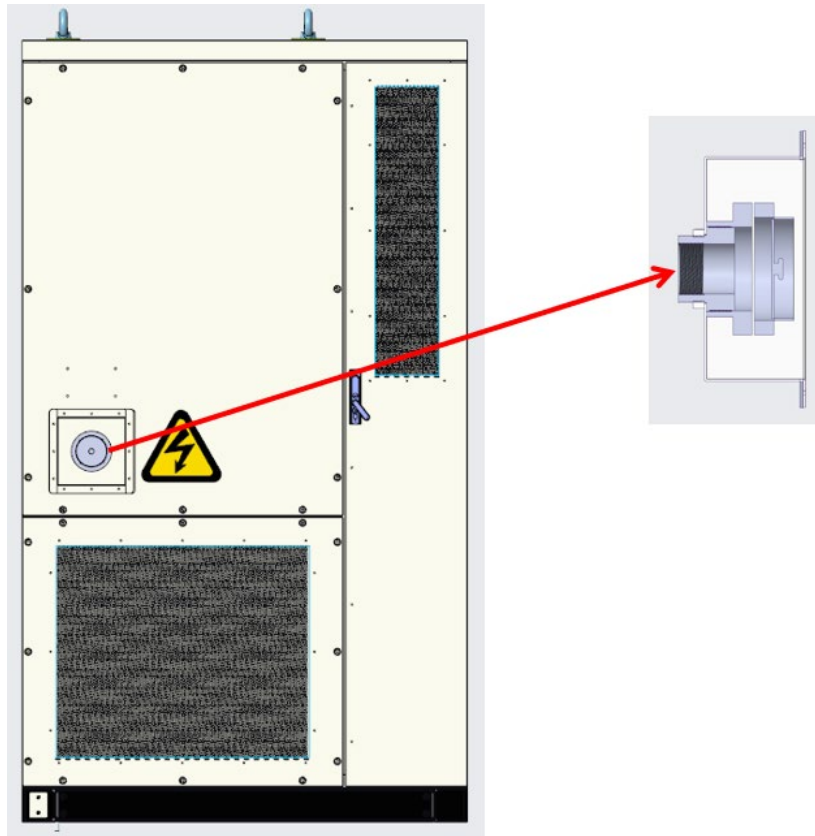

Fig. 16. Water fire interface diagram

### 2.6.5 Water fire interface instructions

The fire hydrant interface model is KA81-G2 1/2" (1/2 inch). Before use, verify that the interface specifications match compatible equipment such as fire hoses and nozzles to ensure proper sealing and stability. Before connecting the hydrant interface, wipe both surfaces with a dry cloth to remove dust, debris, water stains, etc., preventing impurities from affecting the seal. The connection procedure is as follows:

Step 1: unscrew the water interface cover counterclockwise;

Step 2: Align the joint on the fire pipe with the gap of the water fire joint in the cabinet, and tighten it clockwise. It is a snap-on connection without specific torque;

matters need attention :

1. Please ensure that the inner and outer surfaces of the water fire interface are clean; do not block the position of the water fire interface, so as not to affect the use when necessary;
2. Water fire interface must be used by professional firefighters or under their guidance.

## 2.7 Battery management system BMS

Each battery Pack is equipped with a battery management unit. Each system contains a battery control unit, main control unit, etc., which are installed in the energy storage cabinet.

The battery management system is used to monitor the voltage and temperature of a single cell and the total current of a single cluster, calculate the SOC of the battery cluster, and store necessary information and historical data.

The battery management system units communicate in real-time via CAN bus. The main control unit transmits operational status and alarm information of the battery cluster to the energy management unit, while simultaneously receiving real-

time operation commands from the energy management unit. The system automatically performs high-voltage and thermal management, coordinates the automatic balancing function of the entire energy storage system's batteries, and automatically calibrates the State of Charge (SOC) when necessary based on calculations. The secondary architecture is illustrated below:

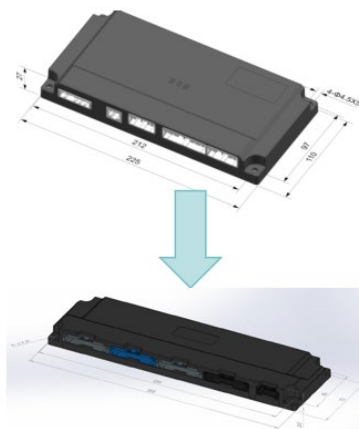

*Fig. 17. Energy storage BMS topology diagram*

## 3 Site selection and relocation

### 3.1 Site selection requirements

#### 3.1.1 Installation environment check

#### **WARNING**

- Please do not install this product in places outside the environmental technical index requirements.
- This product should be far away from water source, heat source and inflammable and explosive articles.
- Try to avoid installing this product in an environment with conductive dust, high density dust, volatile gas, corrosive substances and excessive salt.

#### 3.1.2 Installation environment requirements

Environment	Request
Atmospheric environmental requirements	Working temperature range: -25°C ~+55°C Relative humidity: 0-95% Atmospheric pressure: 86kPa~106kPa No conductive dust and corrosive gases. Keep away from heat sources and water
Landing	Ensure that the cabinet is grounded stably and reliably. The resistance of the grounding system must be $\leq 100m \Omega$
Fire extinguishing system	For safety reasons, fire extinguishers must be installed near the cabinet.
Site requirements	The ground should be flat and firm, with a slope of less than 5%. Necessary drainage measures. Add fencing to prevent people from accidentally entering electrical areas.

#### 3.1.3 Site requirements

The cabinet of this product must be installed on concrete or other non-combustible surface. The installation plane must be guaranteed to be level, firm, flat, and have enough bearing capacity. Dents or tilts are prohibited. If necessary, expansion screws should be added to fix the cabinet.

When building the foundation, it is necessary to consider the problem of power supply of energy storage cabinet, and it is necessary to reserve trench or inlet hole.

The energy storage cabinet adopts the way of lower inlet line. In order to prevent foreign objects from entering, there is no inlet hole on the side of the energy storage cabinet, so it needs to be connected through the trench. Therefore, the trench should be preset on site.

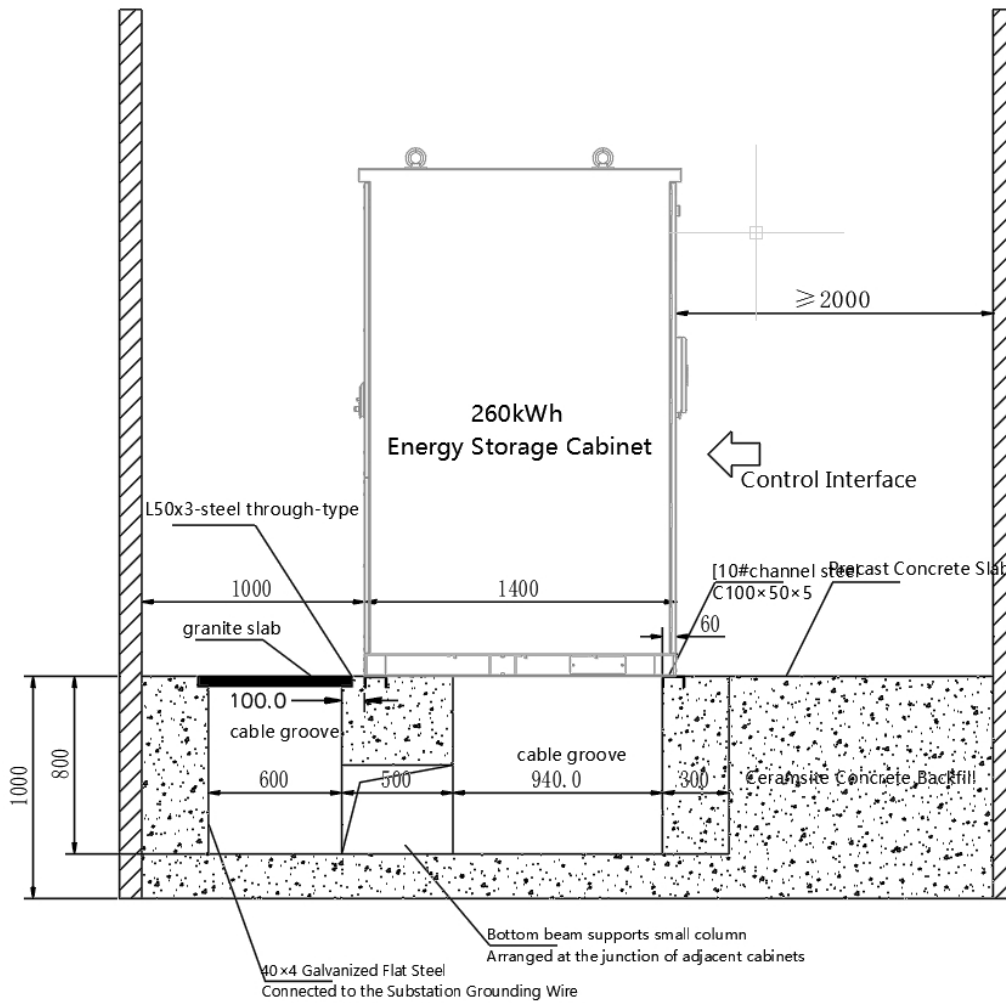
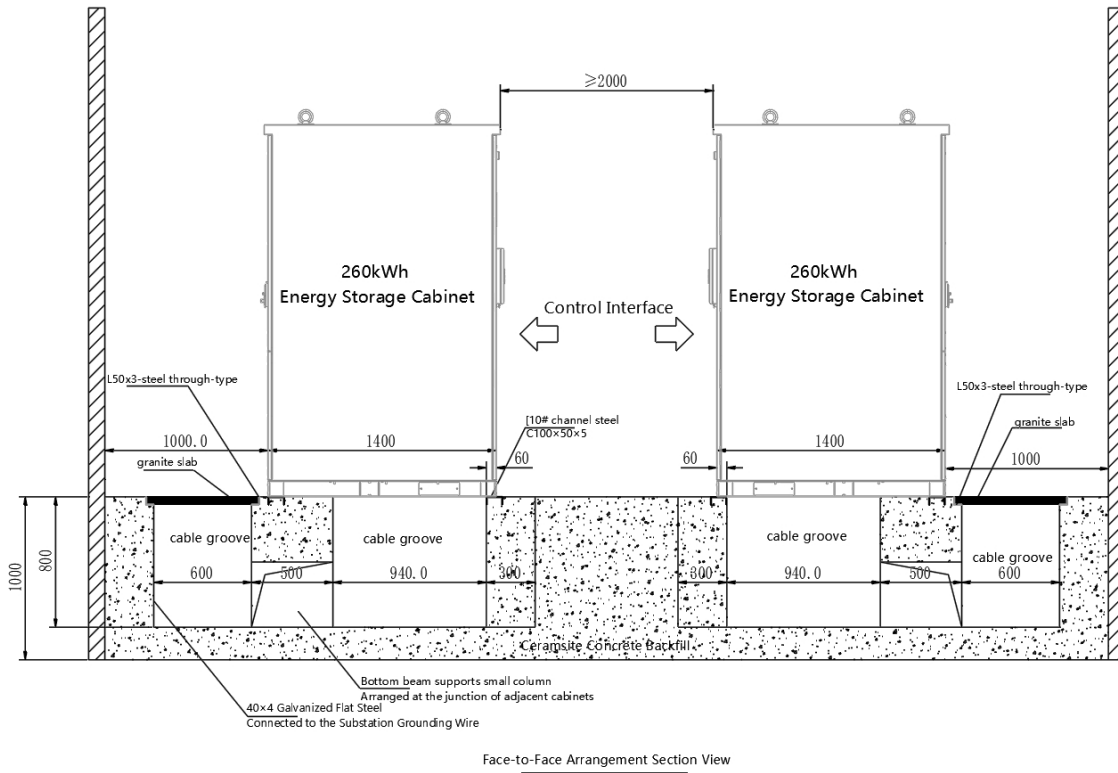

Fig. 18. Schematic diagram of ground foundation requirements

## WARNING

- Cable specifications: Ensure that the power cable connection matches the maximum current requirements of the equipment.
- Project layout: ensure the reasonable layout of power equipment, batteries and other construction processes.
- Cabling Layout: Ensure wiring is properly arranged and organized, with moisture-proof and corrosion-resistant measures implemented. Trenches must incorporate dust-proof and rodent-proof designs to prevent foreign object intrusion. When laying cables, communication lines, power lines, and signal lines should be installed separately, while DC and AC circuits require separate routing. The distance between different cable types must exceed 300mm.
- At least two or more people should operate the installation site.

Ensure a certain installation and maintenance space between the cabinets to meet the following installation distance and national specifications.

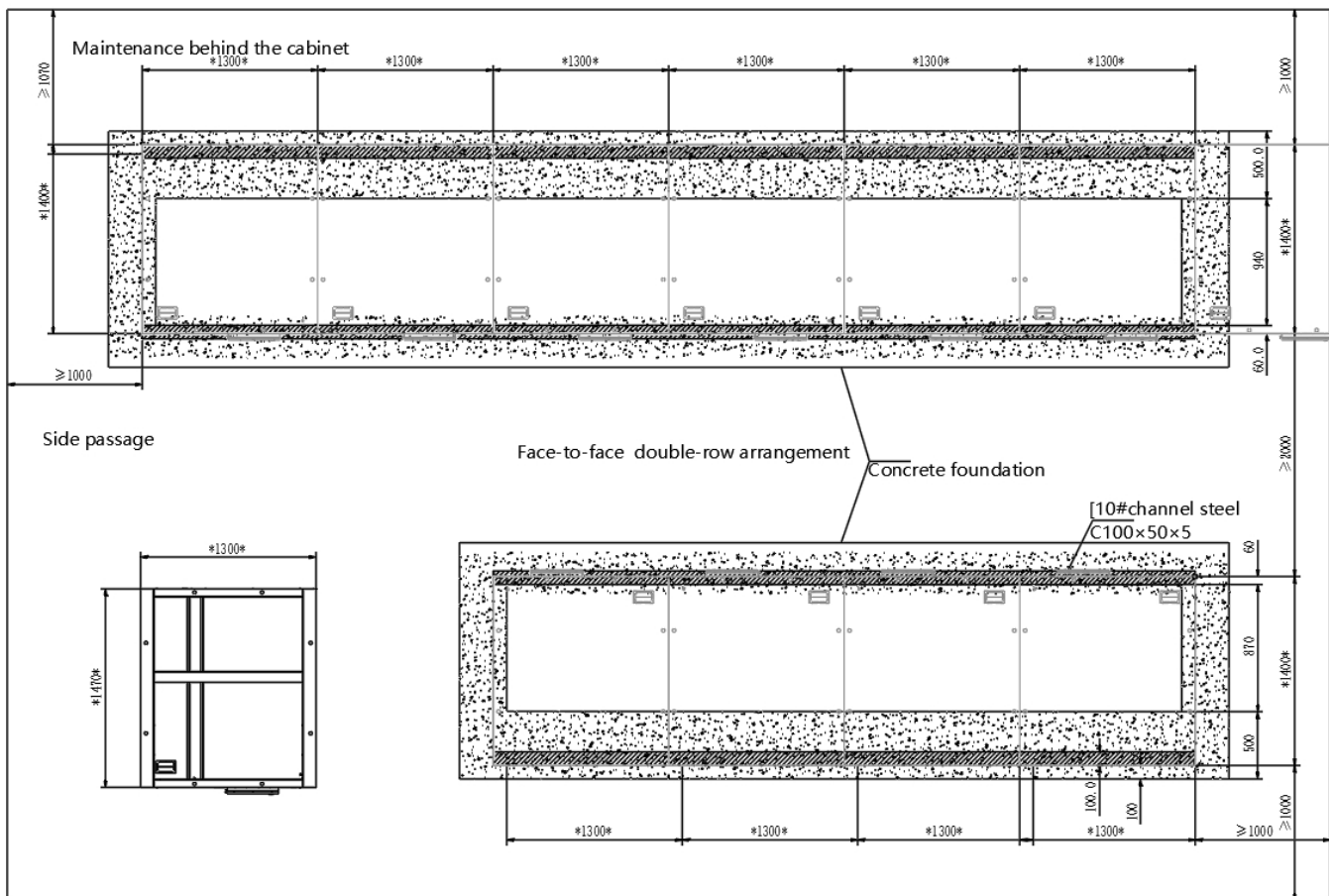

Fig. 19. Installation distance diagram

## 3.2 Installation preparation

### 3.2.1 Safety tips















When installing the equipment, ignoring the following safety tips may cause damage to the equipment, personal injury or serious casualty. Please strictly follow the following safety tips.

## **DANGER**

- Energy storage unit cabinet installation must be carried out by professionals in accordance with all warning prompts.
- Before installation, ensure that the mechanical strength of the installation position is sufficient to support the weight of the equipment, otherwise mechanical hazards may occur.
- When installing, do not wear loose clothes or accessories, operators must be equipped with personal protective equipment, otherwise there may be electric shock and life danger!

### 3.2.2 Installation preparation

The tools and materials that may be used during installation are as follows.

No.	Name	Model	Diagram
1	Security belt	Rubber road cone 70cm	
2	Double ladder	Wide step ladder 1.9m	
3	Helmet	3M glass reinforced plastic conventional red	
4	Gloves	3M thick anti-electricity (DC insulation)	
5	Insulating shoes	3M	
6	Safety Goggle	3M	
7	Multi-meter	1 KV range	
8	Clip-on ammeter	2KA Scope	
9	Companion ladder	Lift height above 2.2m	
10	Jacket	Be in common use	
11	Band tape	100m	
12	Forklift	Be in common use	
13	Electric screwdriver	Be in common use	
14	Insistometer	Be in common use	
15	Diagonal pliers	Be in common use	

16	Pliers	Be in common use	
----	--------	------------------	---

### 3.3 Goods received inspection

#### CAUTION

- When receiving goods from the transportation company, it is necessary to carry out careful inspection of the products to ensure that they are intact.
- Check each shipment against the supply order. If any goods are missing or damaged, notify the carrier immediately.
- Handle energy storage cabinets carefully to avoid any damage to the battery.

### 3.4 Storage precautions

After users buy energy storage cabinets, temporary storage and long-term storage must pay attention to the following points:

Short-term storage temperature range for energy storage products (1 month):  $-25^{\circ}\text{C}$  to  $55^{\circ}\text{C}$ ; long-term storage temperature range:  $0^{\circ}\text{C}$  to  $35^{\circ}\text{C}$ . The monthly average relative humidity should not exceed 90%, and the environment must be free from corrosive or flammable gases. Storage facilities must maintain good ventilation, be free from alkaline or acidic corrosive gases, avoid strong mechanical vibrations or impacts, and exclude strong electromagnetic fields or direct sunlight exposure.

The capacity is maintained at 30 to 50 percent of the storage, and the battery is charged every three months. The maximum discharge and charge interval should not exceed six months.

#### CAUTION

- When storing, try to pack it in the company's packaging box as far as possible.
- If the battery is not stored for a long time according to the above instructions, the cycle life will be significantly shortened.

### 3.5 Carry

#### 3.5.1 Handling precautions

##### Forklift handling

#### CAUTION

- The energy storage unit must be placed on a flat, firm ground that can support the weight of the equipment.
- Energy storage integrated cabinet The integrated cabinet is heavy and the center of gravity is high. The equipment can not be placed on a slope with an inclination greater than 5 degrees.
- Energy storage integrated cabinet The entire cabinet is only allowed to be transported in the way indicated on the packing box, and is not allowed to be transported upside down or sideways.
- During transportation, it should be avoided to throw, rain, strong radiation and corrosion erosion, and prevent collision and strong vibration.

## Crane handling

### CAUTION

- When a crane is used to carry the equipment, the load capacity of the carrying equipment must be greater than the weight of the equipment.
- The lifting and carrying must be achieved by the auxiliary lifting rod at the bottom of the equipment, and the lifting height shall not be higher than 0.3m.
- When lifting and moving the equipment, the equipment remains upright.

## 3.5.2 Moving steps

### 3.5.2.1 Forklift handling

The packaged energy storage cabinet is transported by forklift under the pallet at the bottom of the package. The energy storage cabinet can also be removed from the package and transported independently. Operators must be trained to pay attention to the forklift should be transported from a specific position on the wooden lifting board, otherwise it may overturn.

1. Adjust the width of the forklift foot so that the center of gravity is in the center of the forklift foot.
2. Insert into the position shown below.

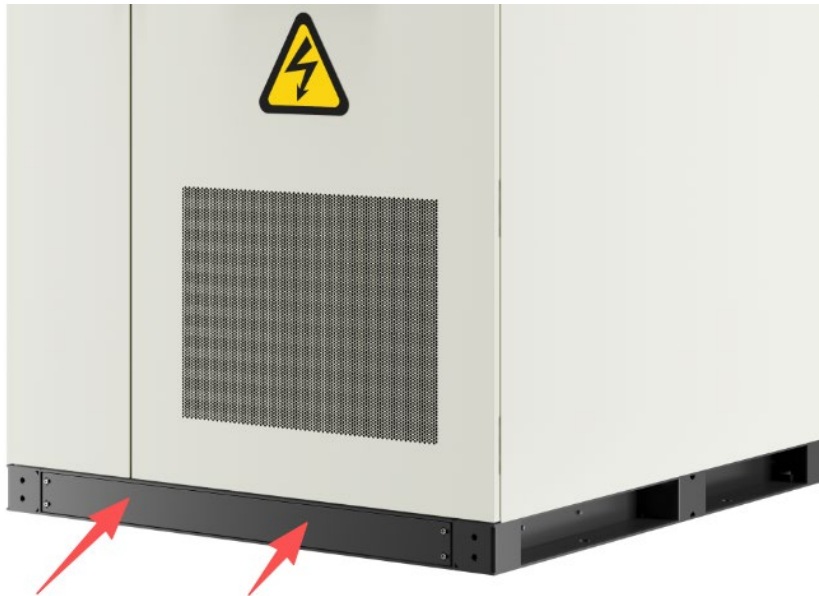

Fig. 20. Forklift handling diagram

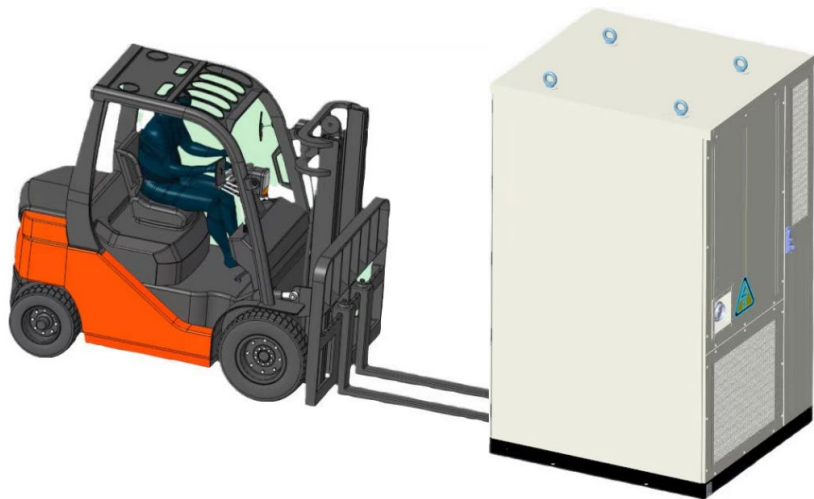

Fig. 21. Forklift handling diagram

3. The forklift opening at the bottom of the energy storage cabinet should be reinstalled with the forklift cover after the equipment is installed.

### 3.5.2.2 Crane handling

Flexible straps or straps should be used. A single strap should be able to bear a weight of more than 4t.

The binding position is fixed as shown in the figure below.

Before lifting the crane, test lift to confirm that the straps can bear the weight of the energy storage cabinet and lift without tilting.

The hook position should be at the center of gravity. After lifting, the swing Angle should be less than 10°.

Before moving, make sure that the front door lock of the cabinet is locked to avoid injury caused by sudden opening during moving.

Handle with care during takeoff and landing to avoid shock or vibration.

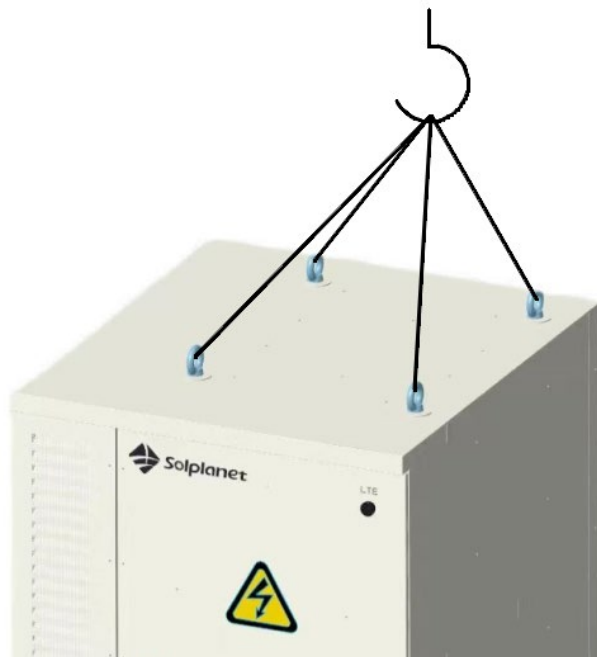

Fig. 22. Crane handling diagram

## 3.6 Packaging disassembly instructions

Energy storage cabinet unpacking and packaging disassembly guide

Before opening the box for the first time, please be sure to read the full content of this guide carefully. Incorrect operation may cause equipment damage or personal injury.

### 3.6.1 Safety warnings and preparations

- Personnel requirements: It is recommended that at least two or more trained professionals work together.
- Personal protection: protective gloves, puncture-proof safety shoes and safety glasses must be worn during operation. It is strongly recommended to wear cut-resistant gloves when handling steel belts.
- Tool preparation: Prepare the following tools:
  - ✧ Forklift (rated load 5T)
  - ✧ Rubber hammer or wooden hammer (used to loosen the box, do not use iron hammer directly)
  - ✧ Pliers (optional for separating box panels)
  - ✧ Site requirements: Choose a flat, firm and barrier-free site for operation.

#### **Before opening the box, please confirm:**

1. Check whether the anti-collision and impact indicator of the outer packing box changes color during transportation as the basis for acceptance. Confirm whether there are serious damage, impact dents or water marks. If there is any abnormality, take photos immediately for archiving and contact our transportation or after-sales department.
2. Check the external identification of the box to confirm that the equipment model and number are consistent with your order, and pay attention to the graphic signs such as "up", "careful handling" and "moisture-proof".

### 3.6.2 Step-by-step disassembly process

#### **Step 1: Identify the box structure**

- ✧ The steel belt box is composed of the top cover, the bottom tray and the four side plates, which are fixed by the box lock. Please first observe the structure of the box to understand the position of the lock and the steel belt.

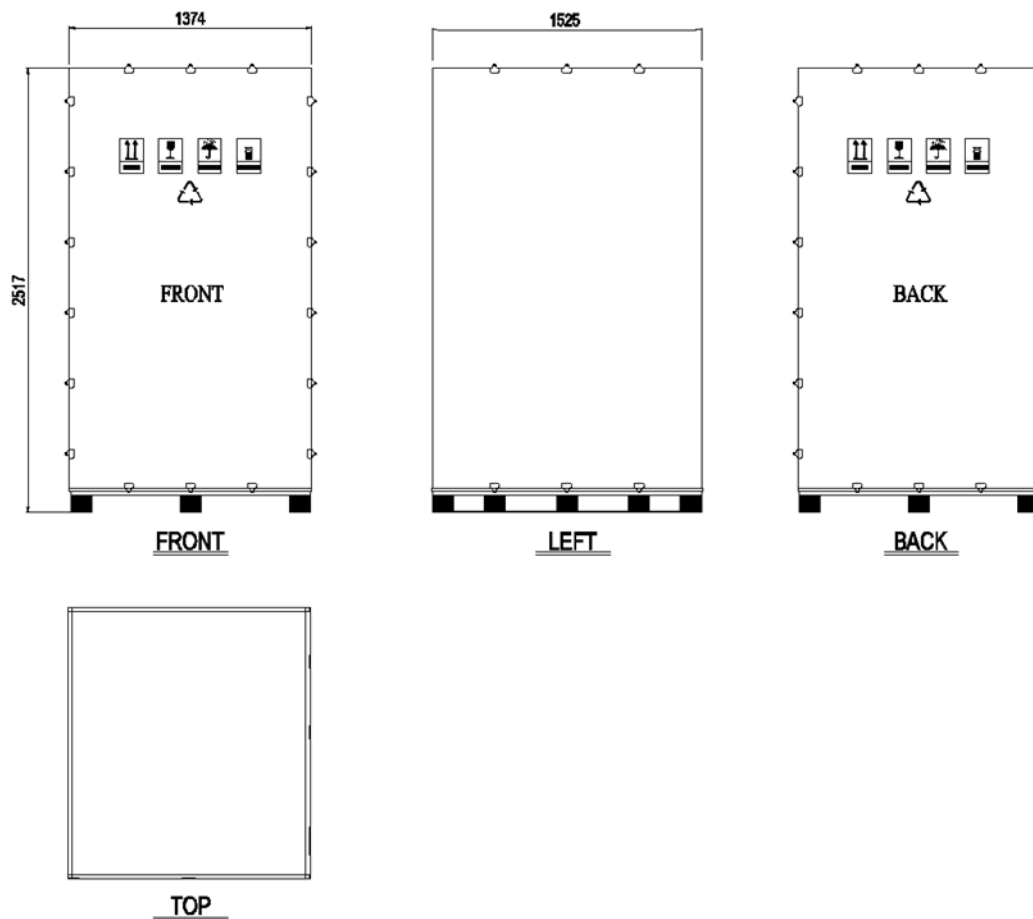

**Step 2: Open the box lock**

- ① Find the metal locks connecting the top cover to the side plate and the side plate to the base.
- ② Use a crowbar to move the metal lock and then use a rubber hammer to gently tap the wrench part of the lock upward to release it from the locked state.
- ③ Open all the locks.

**Step 3: Remove the wooden box panel**

- ✧ After all the locks are opened, knock them with a rubber hammer in turn to remove the top cover and the surrounding side plates.

**Step 4: Remove the device from the fixed position**

- ✧ The equipment is fixed to the bottom tray with 4 M12\*40. Use a wrench to remove the cabinet fixing bolts.

**Step 5: Remove the device**

- ✧ Use a forklift (rated load 5T) to horizontally remove the equipment from the bottom pallet and move it to the designated location.
- ✧ Do not drag the tray on the equipment to avoid scratching the bottom surface of the equipment.
- ✧ During the process of lifting, lowering and moving, it must be tested to ensure that it is slow and smooth;
- ✧ Safety considerations during forklift handling are recommended. It is recommended to tie a safety belt around the integrated cabinet and connect it to the forklift beam.

**Step 6: Remove the wire winding film from the PE bag and pearl cotton corner guard**

- ✧ After using a craft knife to cut open the brushed wrapping film and PE bag, 20 pieces of pearl cotton guard are removed.

✧ Be careful not to scratch the surface of the cabinet when using the utility knife.

### 3.6.3 Precautions and follow-up

Equipment inspection: After the equipment is completely removed, carefully check whether there are any damage caused by transportation and disassembly, and confirm that all random accessories (such as instructions, keys, parts box) have been found.

Problem report: If any damage or loss is found, stop the operation immediately, protect the site and contact our customer service department.

## 4 Electrical installation

### 4.1 Safety tips

#### **DANGER**

- Energy storage cabinets must be installed by professionals, and the installation process should be carried out in strict accordance with the user manual.
- Installation personnel must comply with the relevant electrical operation procedures in their country or region.
- Installation personnel must wear protective equipment as required.
- Before installation, all switches inside and outside the front stage of the energy storage cabinet must be disconnected, and wait for 15 minutes to confirm that all cables and the energy storage cabinet are in no power state.
- A warning sign must be left in the off position to prevent re-energization during installation.
- Necessary grounding and short circuit connections are required.
- The electric parts should be treated with necessary insulation materials to prevent harm to personnel.
- This product is often used in industrial strong electric places. During operation, considering that the product contains charged parts and rotating parts, if the necessary cover plate is removed in violation of regulations, or improper use, misoperation and lack of maintenance, it may cause serious personal injury or property loss.
- Corresponding fire extinguishers should be provided at the installation site.
- The safety instructions in this manual must be read and followed. All work by professionals on electrical equipment must always follow the following "Five Safety Rules":
- Disconnect the power supply connection between the input side and output side of the product.
- Ensure that the input side and output side of the product are not reconnected.
- Ensure that the product is internally free of voltage or below the safe voltage.
- Ensure that the product is properly grounded.
- If the voltage cannot be disconnected, cover or isolate nearby live parts that may pose an electric shock hazard.

### 4.2 Electrical connections

#### 4.2.1 External cable wiring

##### 4.2.1.1 Power cable installation

Power line wiring precautions:

#### **DANGER**

- The wrong voltage can damage the energy storage cabinet.
- The incorrect wiring sequence can cause poor contact and may cause fire.
- The cable should be fastened, otherwise it may cause a fire.

Power line wiring steps and cable construction, protection and other process requirements:

1. Confirm that the output switches of energy storage cabinet, high voltage box front and rear are in the open state;
2. Peel off the insulation skin at the end of the cable. The length of the insulation skin peeled off at the end of the cable should be the depth of the wire hole of the copper nose plus about 5mm;
3. According to the selected cable specification, equip with appropriate wire copper nose for crimping:
  - (1) Put the exposed copper core part of the stripped wire into the wire hole of the steel nose;

(2) Use the terminal crimping machine to press the copper nose of the wire, and the number of crimping should be more than two;

(3) It is recommended that the cable specification range be  $95\text{mm}^2 \sim 120\text{mm}^2$ , and the hole diameter of the copper terminal be M10.

#### 4. Installation of heat shrink tube:

(1) Select a heat shrink tube that is consistent with the cable size. The length of the heat shrink tube should be about 2cm more than the wire tube of the wiring copper nose;

(2) The heat shrink tube is put on the wiring copper nose, so as to completely cover the wire hole of the wiring copper nose;

(3) Use a hot air gun to heat the shrink tube and make it shrink tightly.

5. Pass the AC cable through the corresponding wire hole, select screws, spring pads, flat washers and nuts matching with the wiring copper nose to connect and fix the corresponding A/B/C ports and N copper bars, and lock and fix it according to the recommended torque of  $16\sim 18\text{N} \cdot \text{m}$

The wiring position diagram of the power line input side is as follows.

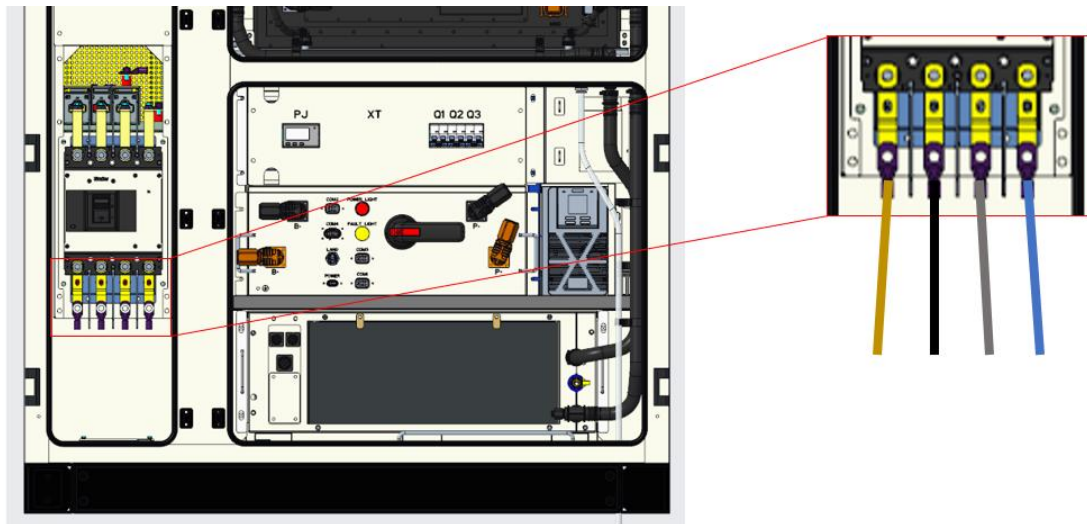

Fig. 23. Power line input side diagram (mm)

#### 4.2.1.2 Pressing the OT/DT terminal

##### 1. OT/DT terminal requirements

- Use copper terminals when copper core cables are used.
- Use copper terminals when copper-clad aluminum cables are used.
- When aluminum alloy cable is used, copper-aluminum transition terminal or aluminum terminal with copper-aluminum transition washer should be used.

## ⚠ CAUTION

- It is strictly prohibited to directly connect the aluminum terminal to the terminal block, otherwise it will cause electrochemical corrosion and affect the reliability of cable connection.
- When copper-aluminum transition terminals are used, or aluminum terminals are combined with copper-aluminum transition spacers, they shall comply with IEC 61238-1 requirements.
- When using copper and aluminum transition spacers, the outer contour of the spacer should not be smaller than the outer contour of the OT/DT terminal. Please pay attention to both sides of the spacer to ensure that the aluminum

surface of the spacer contacts the aluminum terminal, and the copper surface of the spacer contacts the terminal strip. It is recommended that the spacer and terminal are purchased from the same manufacturer.

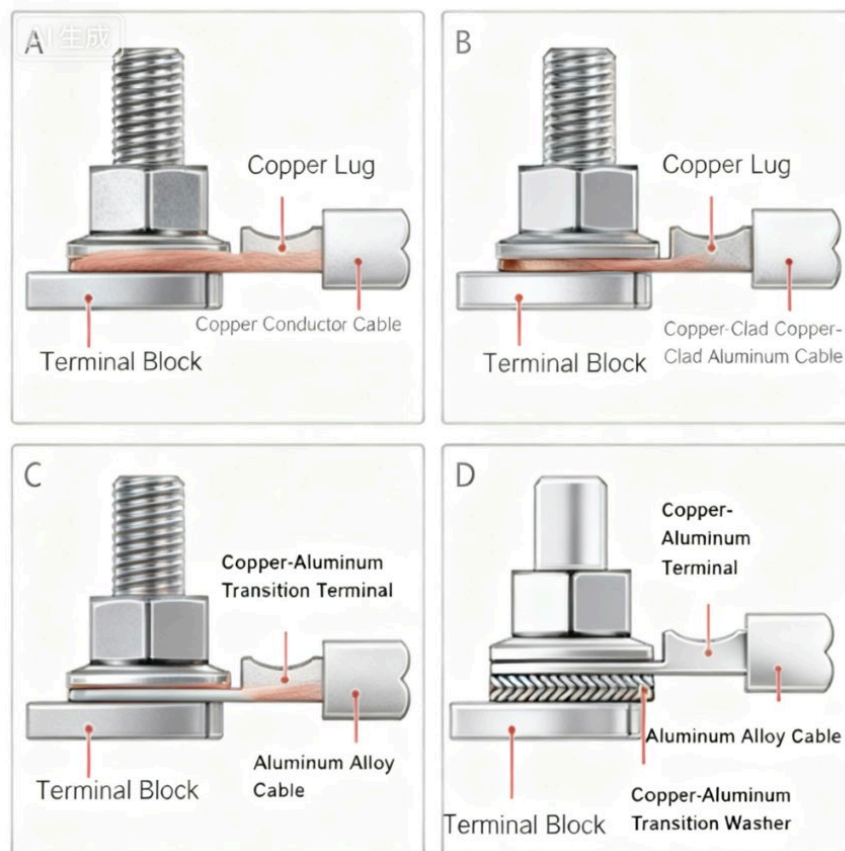

Fig. 24. OT/DT terminal requirements

## 2. Pressing the OT/DT terminal

### ⚠ CAUTION

- When stripping the wire, do not scratch the core.
- The cavity formed by the conductor crimping sheet of the OT/DT terminal after crimping should completely cover the wire core, and the wire core is tightly combined with the OT/DT terminal without loosening.
- The crimping line can be covered with heat shrink tube or insulation tape. Take heat shrink tube as an example. For OT/DT terminals used in strong electric areas, heat shrink tube must be used during crimping.
- When using the hot air gun, please take precautions to prevent burns on the equipment.

Note: The length of the insulation stripped from the end of the cable shall be approximately 3mm in addition to the depth of the crimping hole of the cable copper terminal. As shown in the formula:  $L2 = L1 + 3\text{mm}$ .

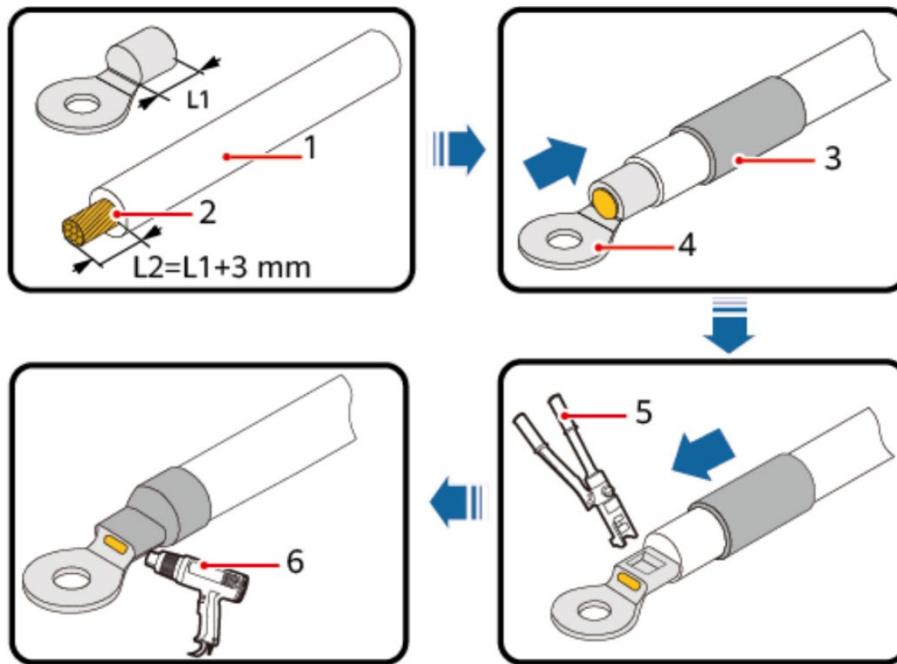

Fig. 25. Crimped OT terminals

- (1) cable      (2) wire core      (3) heat shrink tube  
 (4) OT terminal (5) hydraulic clamp (6) hot air gun

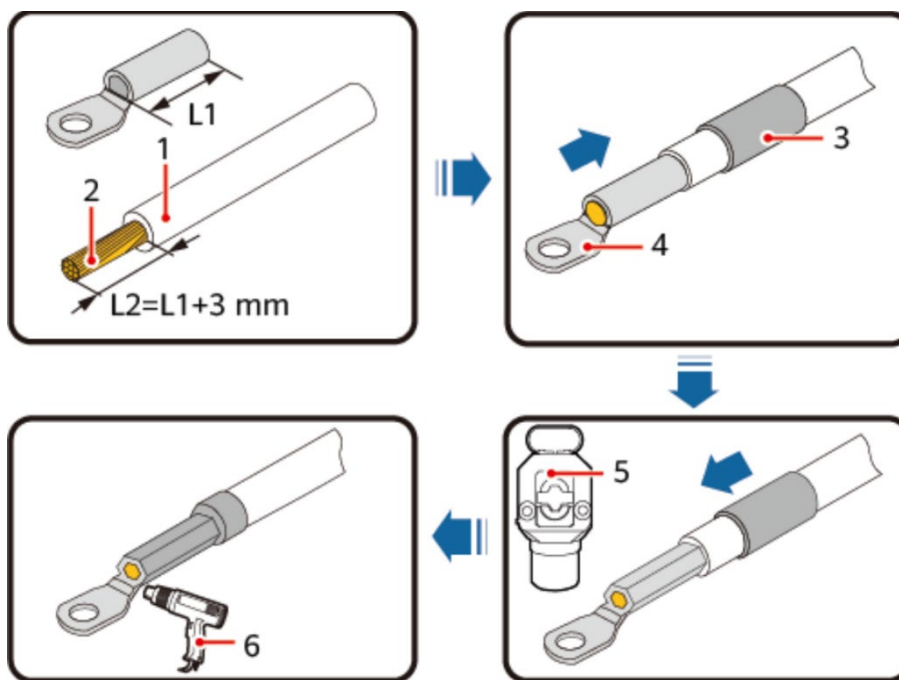

Fig. 26. Crimped DT terminals

- (1) cable      (2) wire core      (3) heat shrink tube  
 (4) DT terminal (5) hydraulic clamp (6) hot air gun

#### 4.2.1.3 Communication cable installation

Note: Communication cables are recommended to use outdoor dedicated CAT6 shielded network cable, and the wire diameter is recommended to be 23AWG~24AWG.

Detailed manufacturing steps of pressing process:



- ① Thread the sheath into the network cable;
- ② Peel off the outer skin of the network cable;
- ③ Twist the metal into strips;
- ④ Separate four pairs of core wires;
- ⑤ Peel off aluminium foil;
- ⑥ The core wire is arranged in 568B as orange white, orange, green white, blue, blue white, green, brown white, brown;
- ⑦ Cut the front end of the wire diagonally;
- ⑧ Thread the core wire into the inner plug;
- ⑨ Cut the front end of the wire;



- ⑩ Insert the core wire into the crystal head to the bottom;
- ⑪ Insert the crystal head into the 8P module port of the wire clamp for crimping;
- ⑫ Fix the tail clip on the wire and cut off the excess ground wire;
- ⑬ Use the network cable clamp to press the tail clip;
- ⑭ Push the sheath up and the crystal head;
- ⑮ The wiring is complete.

When using five or more cabinets in parallel, connect the ①EMS hand-in-hand terminals of adjacent energy storage cabinets through CAT6 shielded network cables. The main cabinet requires an additional ②router to link the ①EMS systems. The communication cable connection points are shown in the diagram below.

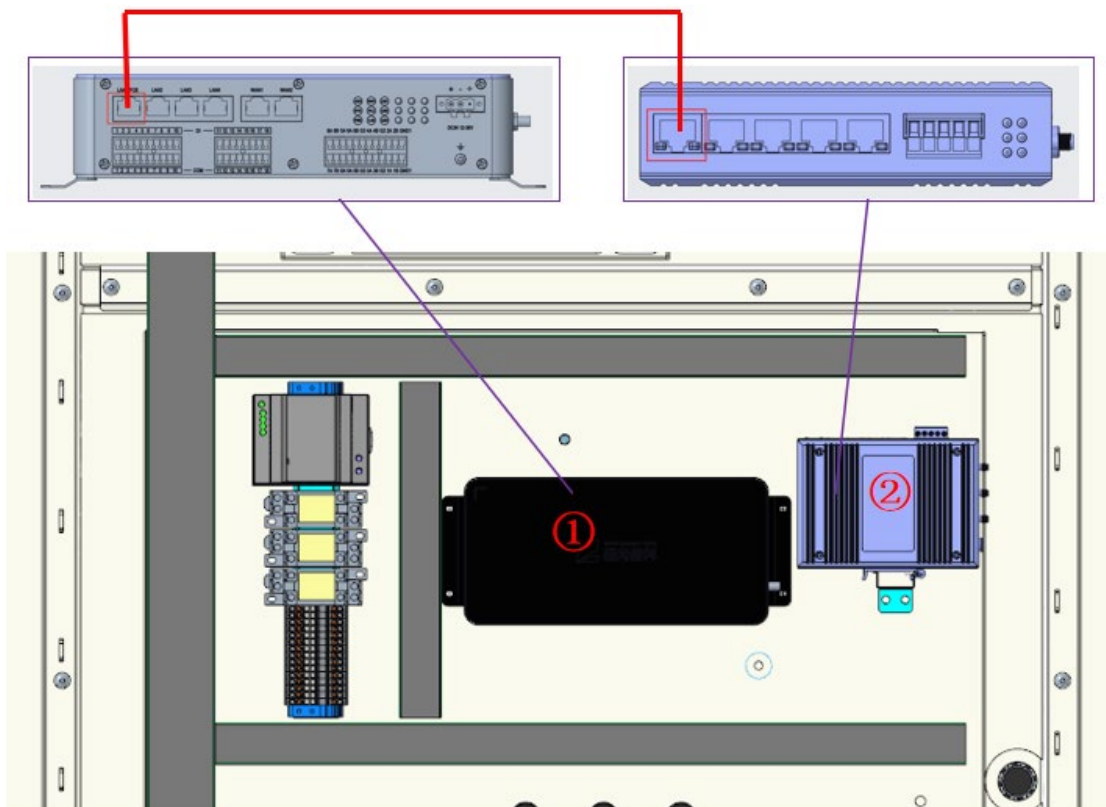

Fig. 27. Schematic diagram of communication line access position

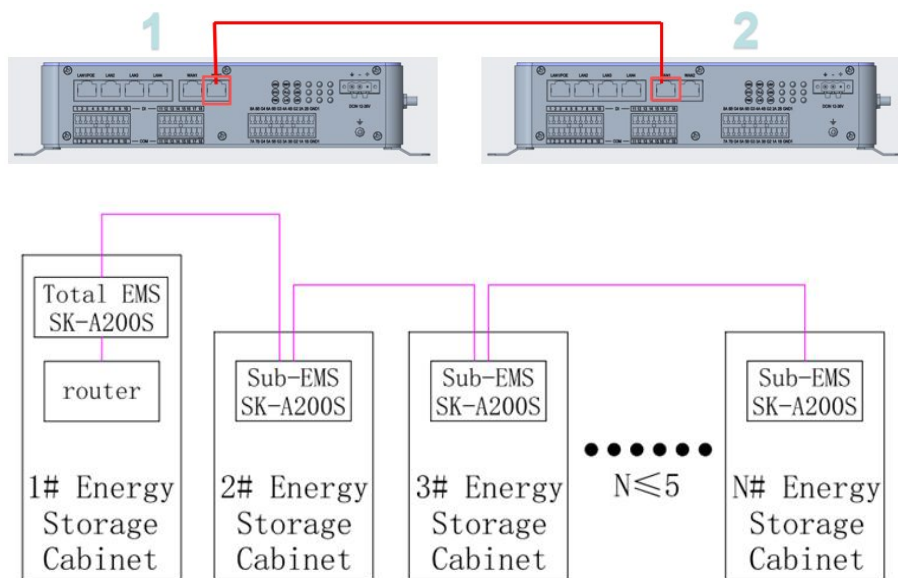
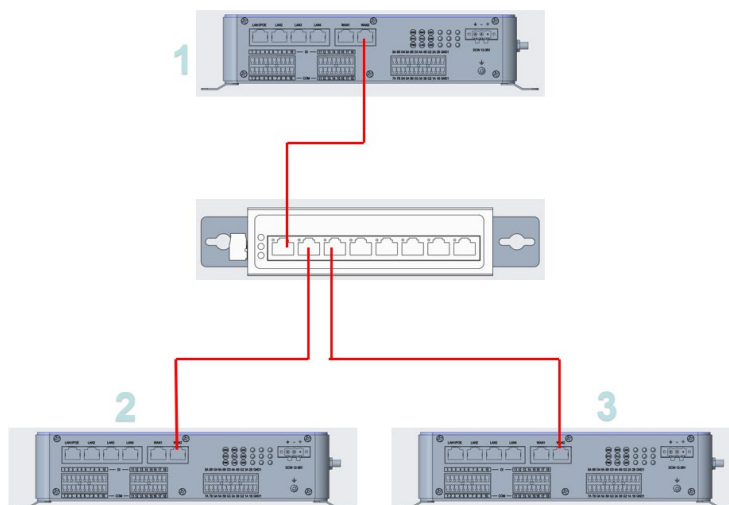

Fig. 28. Schematic diagram of parallel machine wiring

When more than 5 cabinets are used in parallel, additional devices such as a secondary EMS, switch, and router (optional) are required. These devices can be installed in the customer's existing communication cabinet or a newly added communication cabinet.

Main Configuration List

Name	Specification	Remark
Secondary EMS	SK-X200	/
Switch	TL-SF1008	/
Wire Harness	Power Cable, Network Cable	/
Router	MIR655R-W	Optional
Switching Power Supply	HDR-100	Optional
Cabinet	Sizes can be customized	Optional



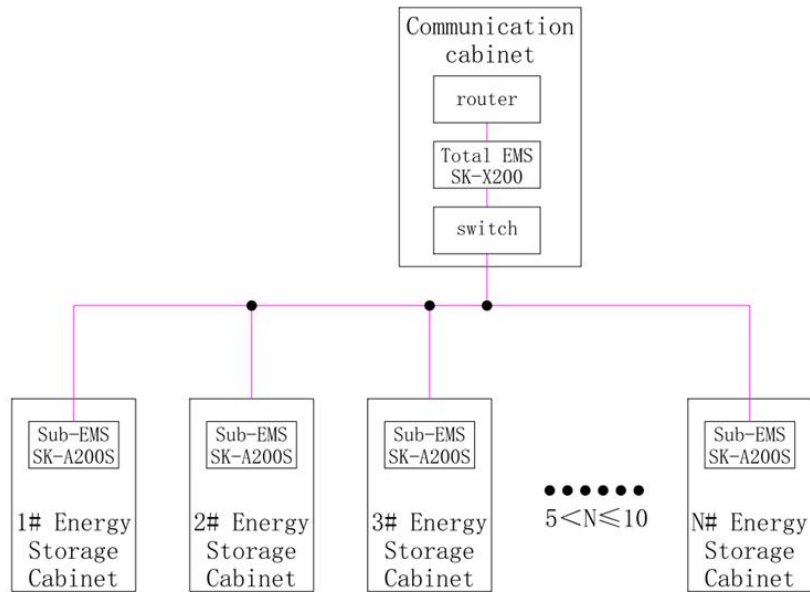
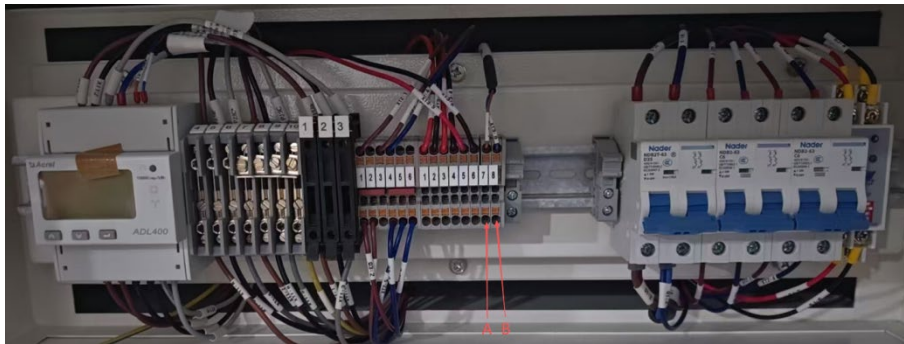

Fig. 29. Parallel machine wiring diagram

#### 4.2.1.4 Communication cable installation



Lead the RS485 communication interface wires of the external anti-backflow electricity meter to terminals XT3: 7/8 (as shown in the figure above).

Note: It is recommended to use outdoor-specific armored shielded twisted pair cables for communication. The recommended wire gauge is 18AWG~20AWG, and the recommended terminal blocks are E0512/E7512.

#### 4.2.2 Installation of external grounding cable

The cabinet must be reliably grounded and a grounding hole is reserved on the inside side of the cabinet. The grounding hole of the cabinet is reliably connected to the field ground point with cable or galvanized flat steel.

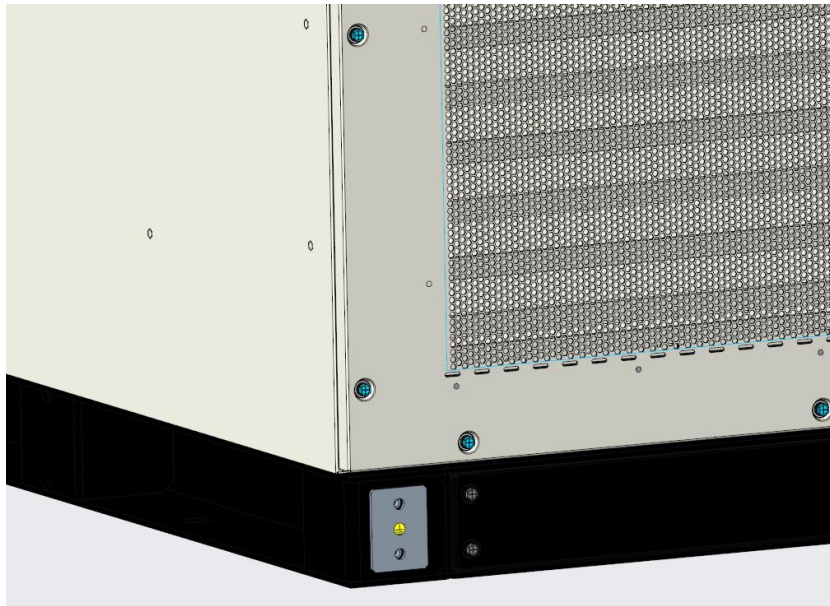

Fig. 30. Schematic diagram of grounding point

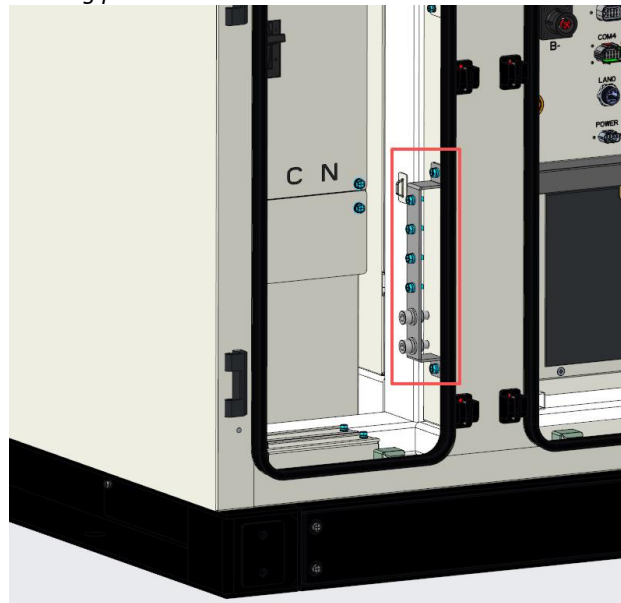

Fig. 31. Schematic diagram of grounding point

When multiple cabinets are used in parallel, the cabinets need to be connected at equal potential.

Grounding instructions:

1. The tightening force of the fixed screw (M10) is 14~16N.m
2. Ensure that the cabinet is reliably grounded, and the connection resistance between the cabinet and the field grounding point is less than  $0.1\Omega$ .

## **DANGER**

- The energy storage battery system is a high voltage DC system. The grounding of the rack must be stable and reliable.

### 4.2.3 Precautions for multi-machine parallel operation and off-grid operation

1. Direct debugging of multiple parallel machines is prohibited. The following steps should be followed:

Single machine debugging: test the charge and discharge function, protection function and parameter accuracy (such as voltage and frequency) of each cabinet one by one;

Multi-machine expansion: after confirming the stability of a single machine, the number of parallel machines should be increased. Each time the number is increased, the load distribution and protection should be retested;

Load test: Connect to the actual load (including inductive, capacitive and resistive loads), run continuously for 72 hours, and record the operating parameters (temperature, current, SOC) of each cabinet to ensure no abnormality.

2. Multi-machine parallel off-grid mode:

1) Important loads should be concentrated on the bus;

2) The load power fluctuates greatly in emergency scenarios (such as temporary operating room suddenly starting equipment), and multiple parallel machines can cope with the fluctuation through redundant capacity. At the same time, it supports "plug and play" and can increase or decrease energy storage cabinets according to actual demand;

3. Fluctuations in renewable energy output require "large-capacity energy storage buffers" (e.g., 1MW photovoltaic power stations need 500-1000kWh of storage capacity). Parallel operation of multiple units enables capacity expansion.

Simultaneously, coordinated charging and discharging among multiple units prevents lifespan degradation of individual battery cabinets caused by frequent charge-discharge cycles (e.g., simultaneous charging of multiple cabinets during high solar output periods versus simultaneous discharging during low output periods).

#### 4.2.4 Fire sealing

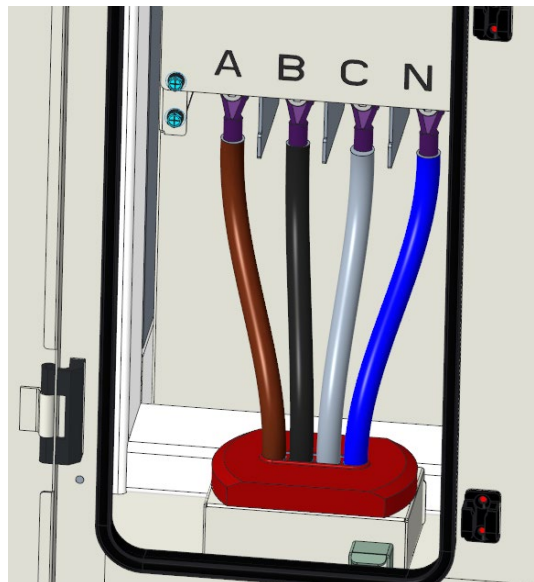

The primary purpose of fire-resistant mud in energy storage cabinets is to seal cable penetrations, cabinet gaps, and other openings, preventing the spread of flames and smoke while providing thermal insulation. The operation must follow the sequence of "preparation → cleaning → shaping → sealing → inspection," with specific steps as outlined below. These procedures should also consider the electrical environment characteristics of the energy storage cabinet (to avoid cable damage and ensure insulation safety):

##### 1. Pre-construction preparation

Select flexible organic fireproof mud that meets the standard (the common type of energy storage cabinet, which is strong in plasticity at room temperature and suitable for cable deformation), check whether the product has a fire certification report, and avoid using expired or lumped fireproof mud (lump can not be molded and the blocking fails);

Basic tools: craft knife (cut fireproof mud / clean rough edges), scraper (press fireproof mud), tape measure (measure gap size), gloves (prevent sticking together + protect hands), cloth (clean surface);

Auxiliary tools: cable protection sleeve (if the cable skin is easy to break, you can first put on a protection sleeve and then seal it), marker (mark the sealing range);

Before construction, the circuit power supply related to the energy storage cabinet should be cut off (or ensure that there is no live part in the working area) to avoid the risk of electric shock;

Wear disposable nitrile gloves (fireproof mud contains a small amount of adhesive, direct contact is easy to remain) and dust mask (if there is dust accumulation inside the cabinet, avoid inhalation when cleaning).

## **2. Grassroots cleaning and gap inspection**

Wipe the cable holes around the energy storage cabinet and the surface of the joint gap of the cabinet with a cloth to remove dust, oil stains, rust and debris (these impurities will cause the fireproof mud to not bond tightly with the base layer and form invisible gaps, which are easy to penetrate by flames);

Measure the width, depth and length of the gap with a ruler to determine the amount of fireproof mud (generally, for each meter of gap, 20mm wide and 20mm deep, about 0.5kg of fireproof mud is needed, which can be estimated according to "volume = length × width × depth");

Check whether the cable is damaged or exposed (if so, it should be repaired with insulation tape first, and then sealed to avoid direct contact between fireproof mud and metal conductor to cause insulation problems).

## **3. Fireproof clay molding and sealing**

Take the fireproof mud as estimated, put it in the palm of your hand or on a flat panel, and rub it repeatedly for 2-3 minutes (so that the fireproof mud is uniform in texture, soft and plastic. If the ambient temperature is lower than 5°C, you can preheat the fireproof mud in about 30°C warm water for 1 minute to avoid stiffness).

Note: The fireproof mud kneaded once should be used up within 30 minutes (if exposed for too long, it will lose water and become hard, and cannot be shaped)

The kneaded fireproof mud is molded into a "long strip" (where the cable is perforated) or a "sheet" (where the plane is narrow) matching the shape of the gap, and the thickness is slightly thicker than the depth of the gap by 5-10mm (reserve space for compaction);

Fill the fireproof mud into the gap slowly to ensure that the inside of the gap is completely filled without cavities and bubbles (you can use a scraper to push the cable into the gap gently to avoid damage to the cable skin with excessive force);

Use a scraper or fingers (wearing gloves) to compact the fireproof mud along the surface of the gap, so that the fireproof mud is tightly attached to the surface of the cabinet and the cable skin, and the surface is smooth without bulging (the bulging part is easy to fall off under external force collision);

Focus on checking the contact surface between the cable and the fireproof mud to form a "seamless package" (if there are small gaps, a small amount of broken fireproof mud can be rubbed into a fine strip to fill them).

## **4. Overall inspection and repair**

Visual inspection: no obvious gap, cavity or bulge at the blocked part, and the fireproof mud is tightly bonded with the cable/cabinet;

Hand pressure check: use fingers to press the surface of fireproof mud, no loosening, falling off, no obvious depression after pressing (if depressed, it means that it is not compacted, and fireproof mud should be added and compacted again);

Use a craft knife to remove the excess fireproof mud (such as the overflow part of the edge), so that the appearance of the blocked part is clean, and does not affect the opening and closing of the energy storage cabinet door and cable maintenance;

If a fine gap is found between the cable and the fireproof mud, rub a small amount of fireproof mud into a thin strip and embed it in the gap and compact it.

### 4.3 Check after wiring

#### **DANGER**

- Do not connect any wire end or connector in the BMS to the positive and negative terminals of the battery, otherwise it may cause a short circuit risk and may damage the circuit board.
- Communication cable connection error can cause battery system failure.

After the wiring is completed, in order to avoid equipment damage and property loss, the following items must be reconfirmed and measured:

Order number	Check item
1	Before measurement, disconnect the circuit breaker on the side of the energy storage integrated cabinet and the power grid to ensure that the energy storage integrated cabinet is not charged.
2	Confirm that the phase sequence is correct and fastened, and measure the resistance between the three phases. It should be in the megohm range. If it is K or smaller, check the line.
3	Check that the electrical connection complies with the design drawings.
4	Confirm that external control cables, communication cables, and grounding cables are tightened.
5	Confirm that the resistance of the grounding wire is less than $0.1\Omega$ . Confirm that the cable is intact, without damage or cracks.
6	Clean the installation area and confirm that no tools or foreign objects are left in the installation area.
7	Fireproof mud is used to seal the cable gaps to prevent small animals from entering.

## 5 Power on and power off the energy storage cabinet

### 5.1 Pre-electrification inspection

Before debugging and running, the following items should be checked:

No.	Check items
1	Check whether there is condensation phenomenon (water film or water droplets on the surface) in the energy storage cabinet and devices. If so, open the cabinet fan to ventilate until the phenomenon disappears. Check the pipeline connection to ensure that there is no leakage.
2	Measure whether the voltage on the input side of the power supply cabinet is within the specified range, and confirm that there is no fault such as phase loss or short circuit.
3	The power input terminals (A, B, C, N) must be connected correctly and securely.
4	The energy storage cabinet must be reliably grounded.
5	Control signal cables are properly and securely wired.
6	The terminal is intact and undamaged, and has been insulated.
7	There are no foreign objects such as wire ends and metal shavings inside and outside the energy storage cabinet that may cause short circuit of signal lines and power lines.
8	The cooling circuit is working normally.

### 5.2 Powering the energy storage cabinet

#### CAUTION

The battery cabinet should be turned on in strict accordance with the following steps, otherwise it may damage the battery cabinet or cause abnormal operation of the battery cabinet.

#### 5.2.1 Operating steps

- 1) Turn on the UPS, press the UPS power switch for a long time ① and release it after hearing the sound for two seconds to complete the startup;
- 2) Rotate the handle switch ② (HVB) in the main control box to ON position;
- 3) Closed front protection circuit breaker ③ (SCB);
- 4) Closed UPS output switch ④ (Q3);
- 5) Press the power button ⑤ (DC Power) of the high pressure tank HVB;
- 6) Closed-circuit plastic case circuit breaker ⑥ (QAC);
- 7) The power supply circuit breaker ⑦ (Q1) of the closed liquid cooling unit is powered;
- 8) The closed UPS input switch ⑧ (Q2) is powered on the mains side of the UPS;

After the power supply is completed, parameters can be set through HMI locally or in the cloud. See EMS operation instructions for details.

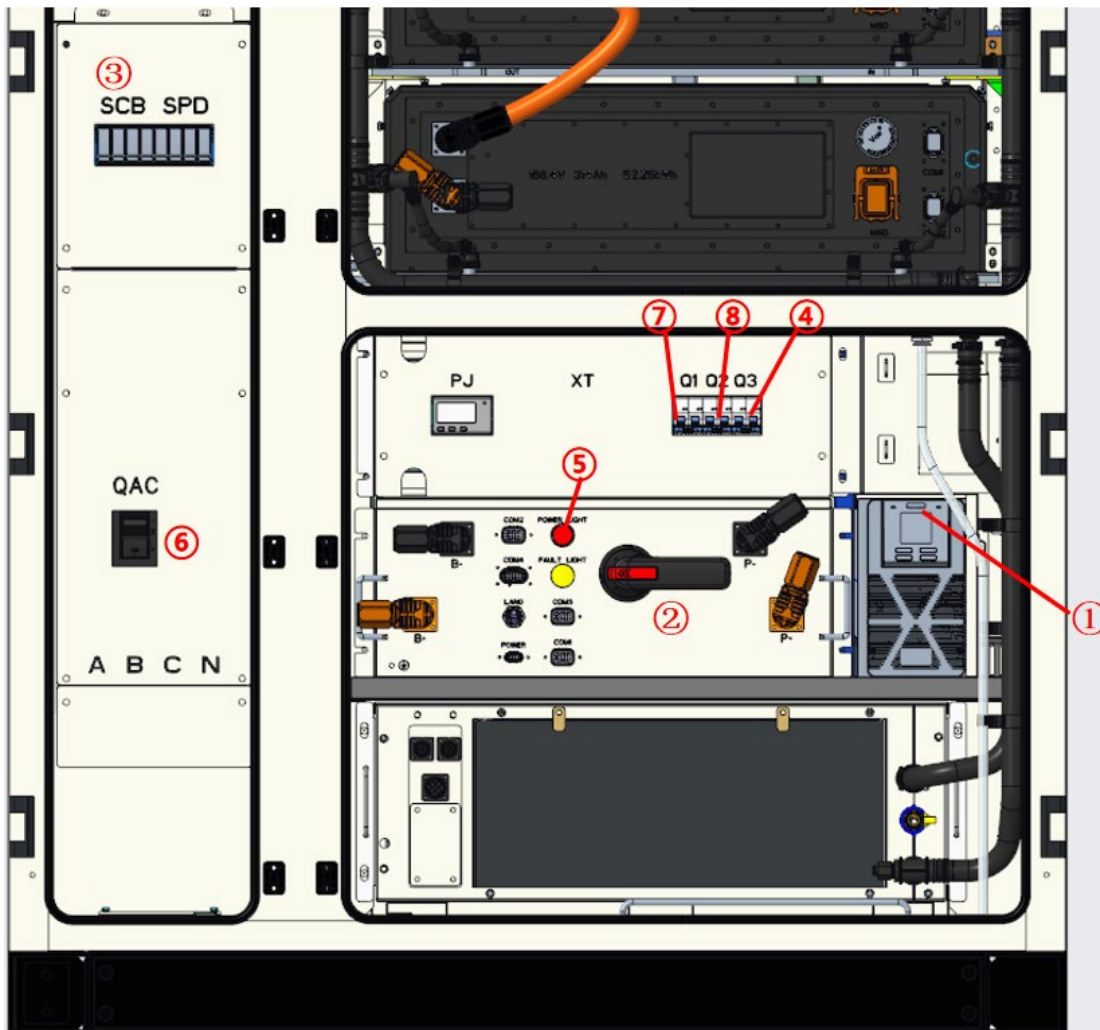

Fig. 32. Operational steps indicator

## 5.3 Power down the energy storage cabinet

### 5.3.1 Operating steps

- 1) The energy storage cabinet stops operation by issuing the "stop strategy" instruction locally or in the cloud through HMI. See EMS operation instructions for details;
- 2) Disconnect the power button ⑤ (DC Power) of the high pressure box HVB;
- 3) Disconnect the UPS output switch ④ (Q3);
- 4) Disconnect the UPS input switch ⑧ (Q2);
- 5) The power circuit breaker ⑦ (Q1) of the disconnect liquid cooling unit is cut off, and the liquid cooling unit is stopped;
- 6) Disconnect AC molded case circuit breaker ⑥ (QAC);
- 7) Disconnect the front protection breaker ③ (SCB);
- 8) Rotate the handle switch ② (handle switch) in the high pressure box HVB to OFF position;
- 9) Turn off the UPS, press the UPS power switch for a long time ① and release it after hearing the sound for two seconds to complete the shutdown;
- 10) The power down is complete.

## CAUTION

There should be a warning mark at the switch to prevent others from accidentally getting power on.

### 5.3.2 5.3.2 Emergency shut down

In case of emergency, take the red emergency stop button on the front cabinet door, EMS sends the shutdown command, and automatically disconnects the power circuit of the high-voltage box in the energy storage battery cabinet.

## CAUTION

- After disconnecting the input power supply of all energy storage cabinets, it is necessary to wait for 30 minutes before opening the door to check the smart energy storage terminal.
- Before opening the cabinet door, confirm that the energy storage cabinet is in no power state.
- Under normal circumstances, please use the normal shutdown steps to shut down the energy storage cabinet. In emergency situations, you must use the emergency shutdown to ensure rapid response and protect life safety, smart energy storage terminals and peripheral equipment.

## 5.4 On/Off-grid switching

Description of operation modes such as grid-connected and off-grid:

During grid-connected operation, the converter connects its AC side to the power grid and its DC side to the battery. Working in coordination with the grid dispatch system, it participates in voltage regulation and frequency modulation to balance grid loads through peak shaving and valley filling. Depending on the selected operating mode, the battery can be charged/discharged at constant voltage, current, or power levels.

In off-grid operation, the converter is connected to the battery on the DC side. The system can output three-phase AC voltage with fixed frequency and effective value to realize continuous power supply for AC side load.

About the operation procedures of black start and manual off-grid switching:

### **I. Manual On/Off-Network Switching in Local Mode:**

Grid-connected to off-grid

- 1) Click "Stop Strategy" on the local display screen;

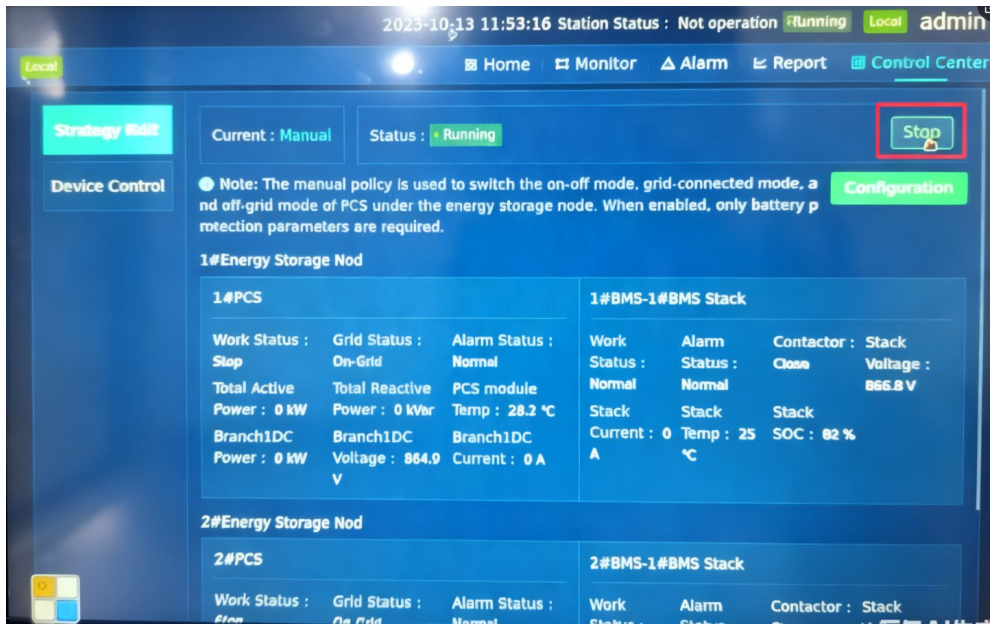

2) Switch to Local Mode on the local display screen;

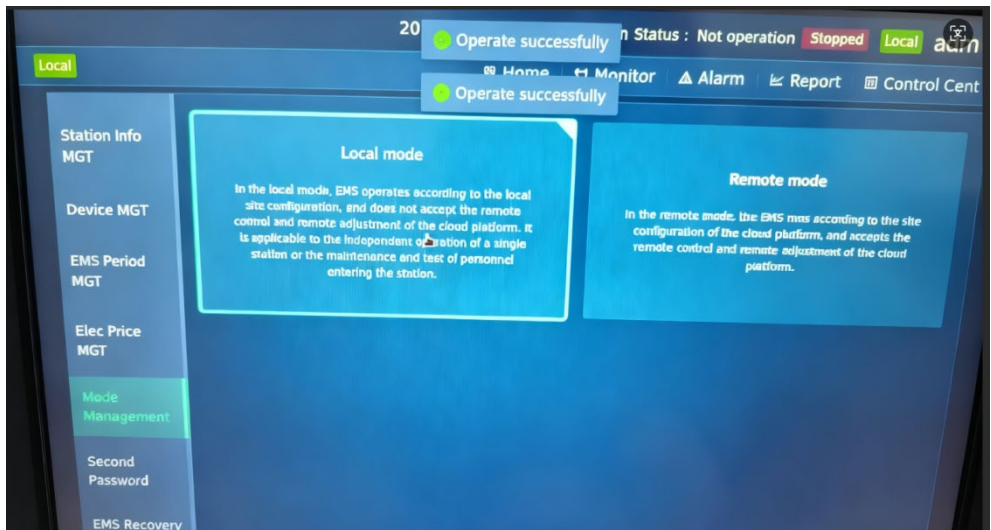

3) On-site operation and maintenance personnel manually open the circuit breaker;



- 4) Configure the strategy: Click "Configure";
- 5) Configure the off-network parameters, and click "Start Strategy" on the local display screen;

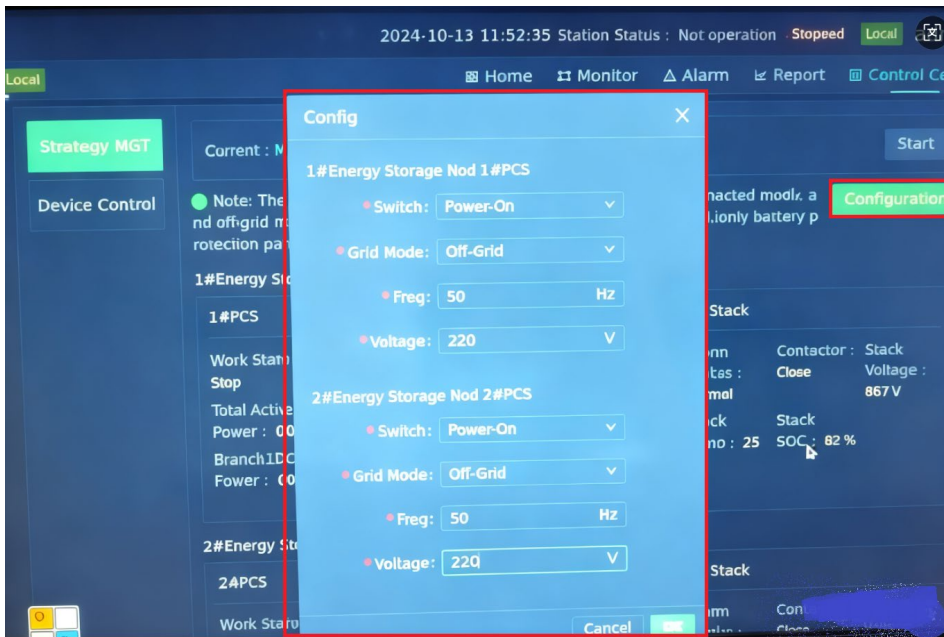

- 6) Check the off-network operation status and complete the switch to off-network mode.

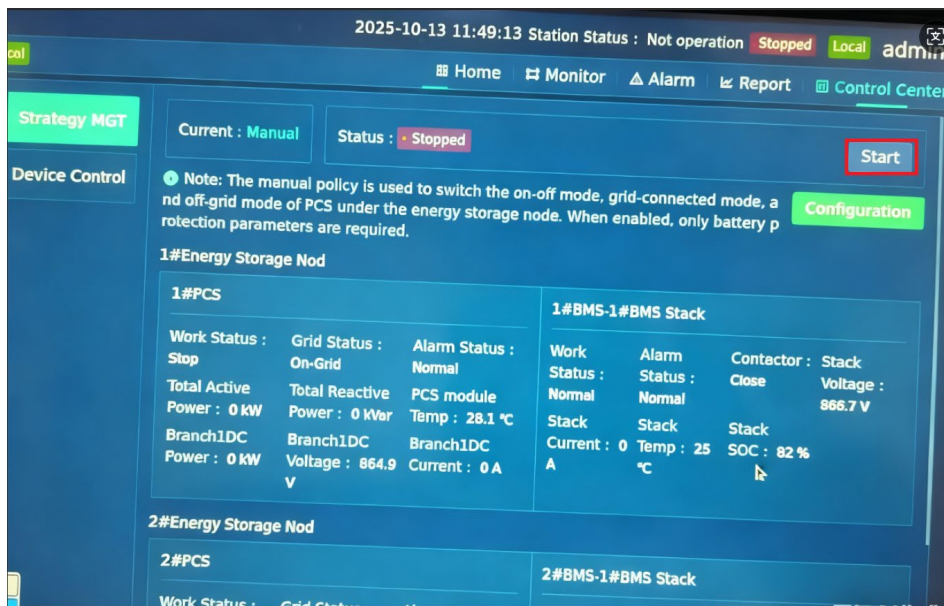

### Off-grid to grid connection

- 1) Click "Stop Strategy" on the local display screen;

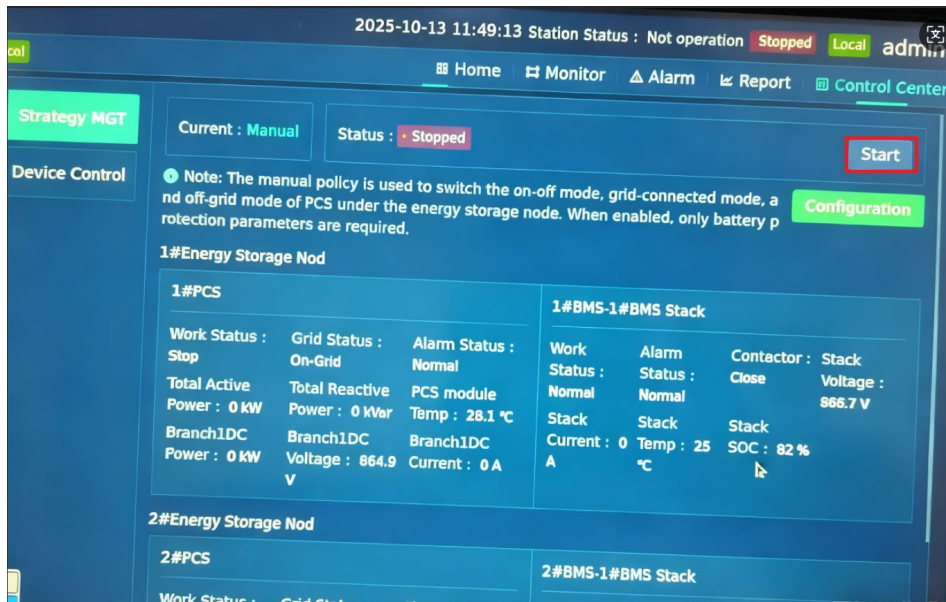

2) Check the shutdown status on the local display screen;



3) Apply AC power (customer manually closes the circuit breaker);



- 4) Click "Configure";
- 5) Configure the on-network parameters;
- 6) Start the On-Network Strategy;

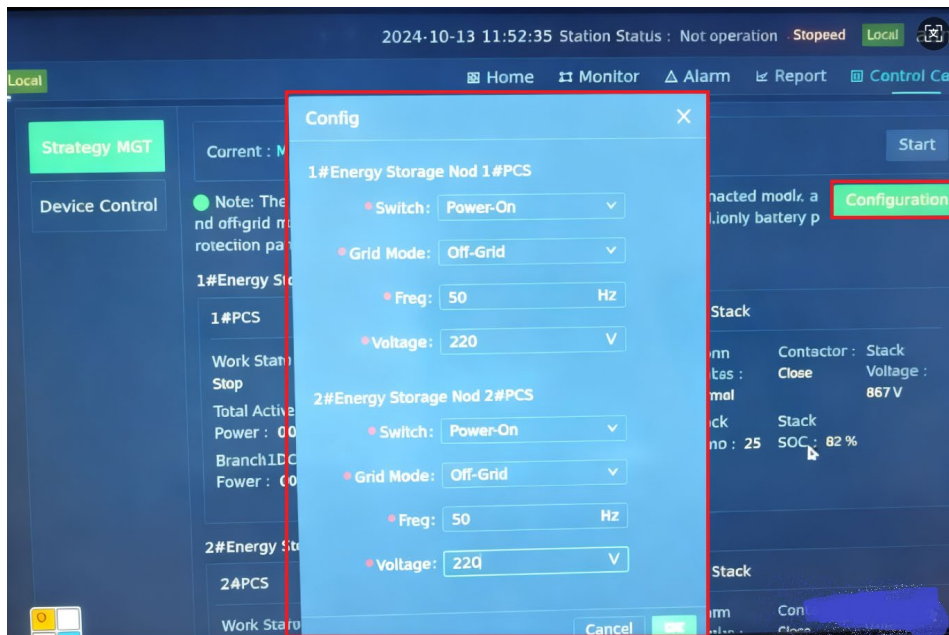

- 7) Check the on-network operation status and complete the switch to on-network mode.

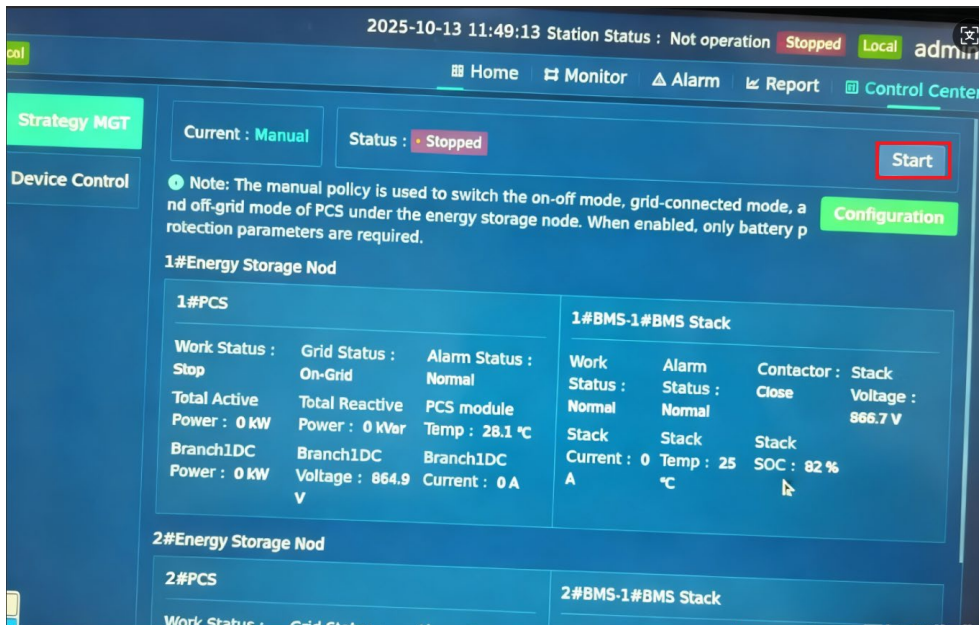

## II. Manual On/Off-Network Switching in Remote Mode:

Switch to Remote Mode on the local display screen

Grid-connected to off-grid

1) Click "Stop Strategy" on the EMS Cloud Platform;

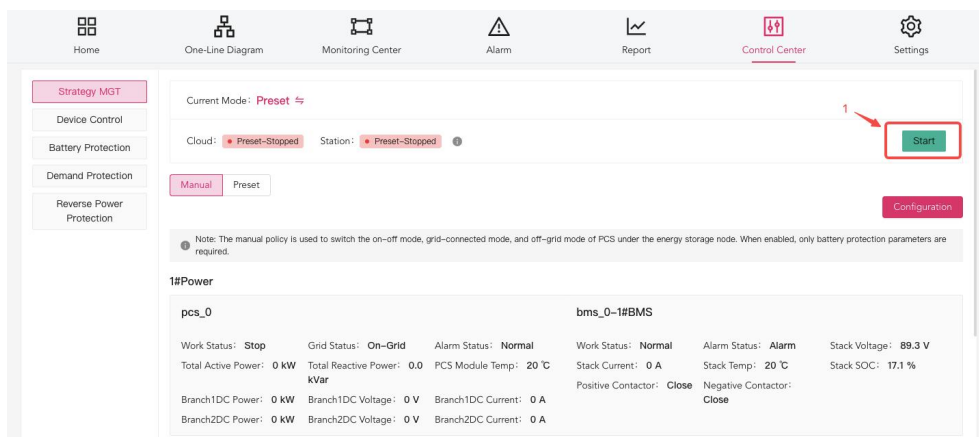

2) Click "Confirm";

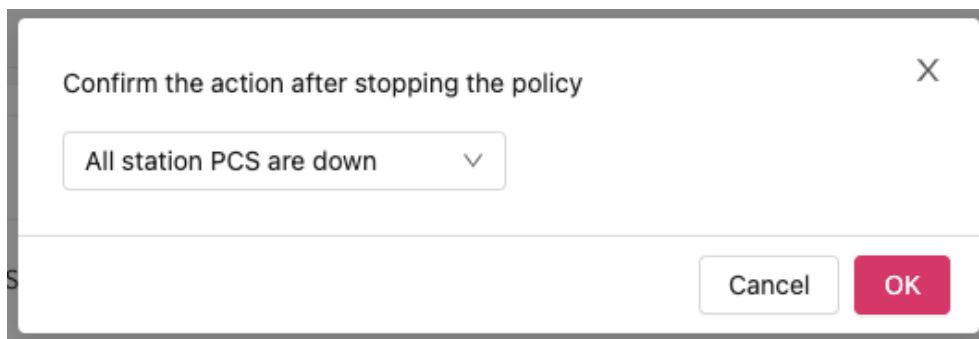

3) On-site operation and maintenance personnel manually open the circuit breaker;



4) Change the mode switching to manual strategy;

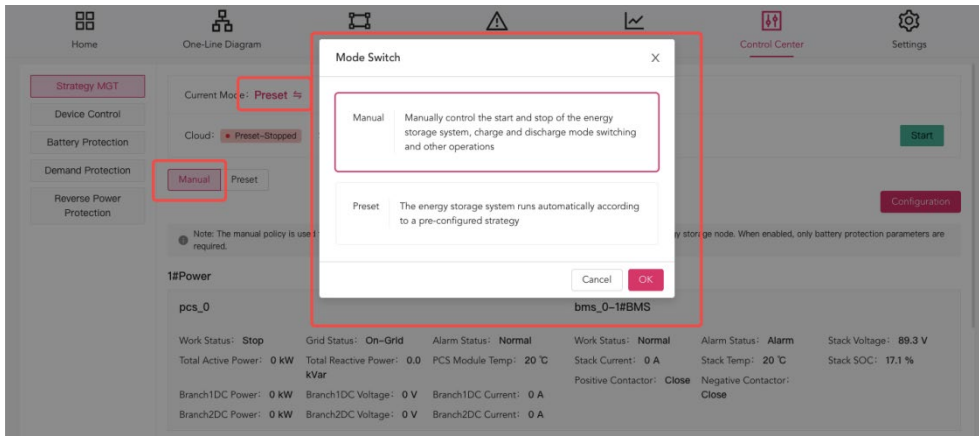

5) Configure the strategy: Click "Configure";

6) Configure the strategy;

7) Click "Confirm";

8) Start the Strategy;

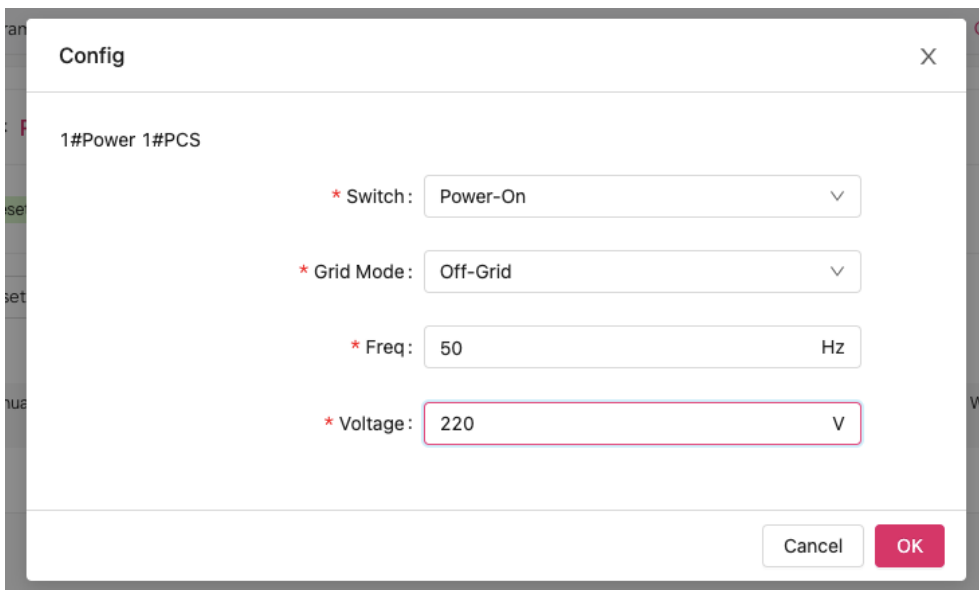

9) Check the off-network operation status and complete the switch to off-network mode.

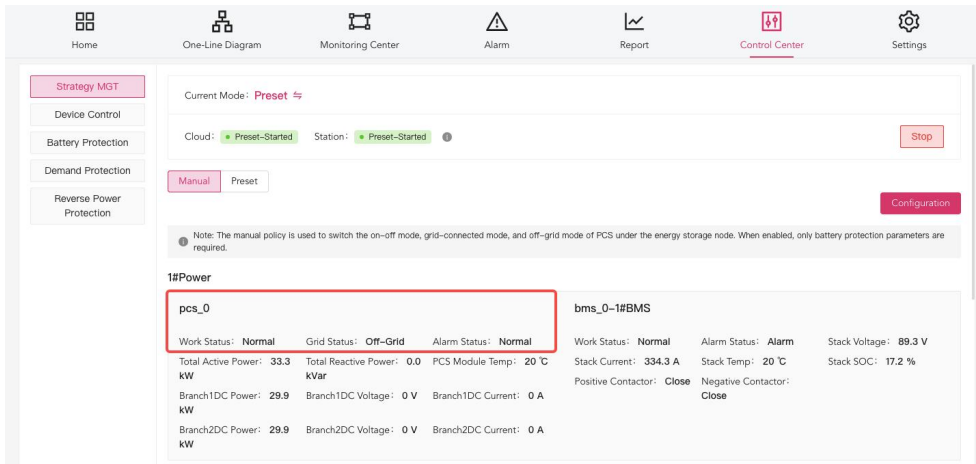

### Off-grid to grid connection

1) Click "Stop Strategy" on the EMS Cloud Platform;

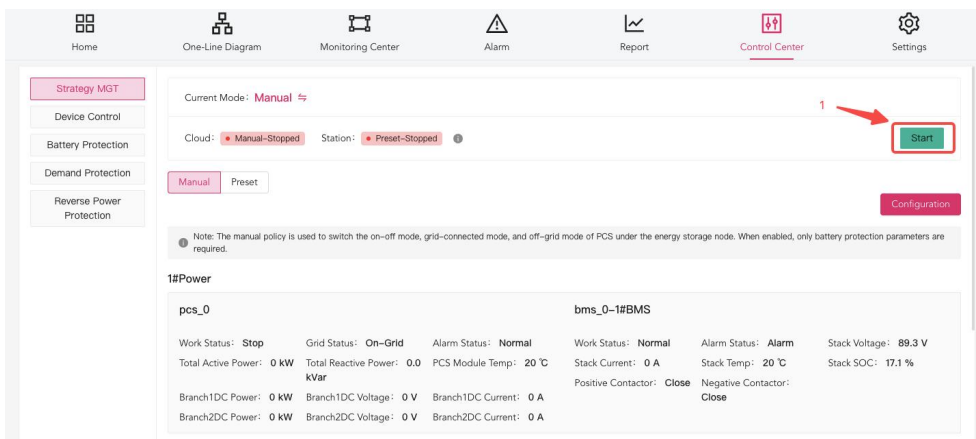

2) Click "Confirm";

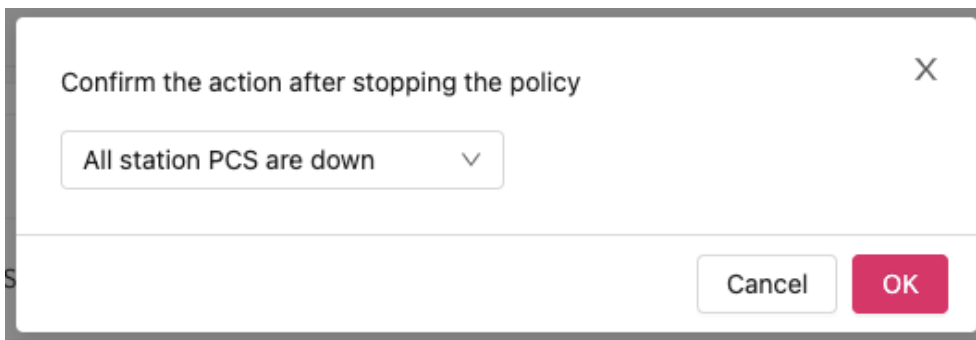

3) Apply AC power (customer manually closes the circuit breaker), on-network configuration;



4) Click "Confirm";

Config
X

1#Power 1#PCS

\* Switch:

\* Grid Mode:

\* Freq:  Hz

\* Voltage:  V

Cancel
OK

5) Start the On-Network Strategy;

6) Check that the startup parameters are normal;

Home
One-Line Diagram
Monitoring Center
Alarm
Report
Control Center
Settings

Strategy MGT

Device Control

Battery Protection

Demand Protection

Reverse Power Protection

Current Mode: Manual

Cloud: ● Manual-Stopped    Station: ● Preset-Stopped

Manual
Preset
Configuration
Start

Note: The manual policy is used to switch the on-off mode, grid-connected mode, and off-grid mode of PCS under the energy storage node. When enabled, only battery protection parameters are required.

**1#Power**

**pcs\_0**

Work Status: ● Stop    Grid Status: ● On-Grid    Alarm Status: ● Normal

Total Active Power: 0 kW    Total Reactive Power: 0.0 kVar    PCS Module Temp: 20 °C

Branch1DC Power: 0 kW    Branch1DC Voltage: 0 V    Branch1DC Current: 0 A

Branch2DC Power: 0 kW    Branch2DC Voltage: 0 V    Branch2DC Current: 0 A

**brms\_0-1#BMS**

Work Status: ● Normal    Alarm Status: ● Alarm    Stack Voltage: 89.3 V

Stack Current: 0 A    Stack Temp: 20 °C    Stack SOC: 17.1 %

Positive Contactor: ● Close    Negative Contactor: ● Close

ASW125K261-PT\_EN\_V02

53

## 7) Issue the Preset Strategy.

Home One-Line Diagram Monitoring Center Alarm Report **Control Center** Settings

Strategy MGT

Device Control

Battery Protection

Demand Protection

Reverse Power Protection

Current Mode: **Manual**

Cloud: **Manual-Started** Station: **Manual-Started** Stop

**Manual** Preset Configuration

Note: The manual policy is used to switch the on-off mode, grid-connected mode, and off-grid mode of PCS under the energy storage node. When enabled, only battery protection parameters are required.

**1#Power**

pcs_0				brms_0-1#BMS			
Work Status:	<b>Normal</b>	Grid Status:	<b>Off-Grid</b>	Alarm Status:	<b>Normal</b>	Stack Voltage:	89.3 V
Total Active Power:	0 kW	Total Reactive Power:	0.0 kVar	PCS Module Temp:	20 °C	Stack Current:	0 A
Branch1DC Power:	0 kW	Branch1DC Voltage:	0 V	Branch1DC Current:	0 A	Stack Temp:	20 °C
Branch2DC Power:	0 kW	Branch2DC Voltage:	0 V	Branch2DC Current:	0 A	Stack SOC:	17.1 %
				Positive Contactor:	Close	Negative Contactor:	Close

# 6 EMS operation declaration

## 6.1 Summary - Station Overview



Module	Explain
Card bar	<ul style="list-style-type: none"> <li>Display Station key information (power station pictures/installed power (kW)/installed capacity (kWh)/total charge and discharge (kWh)/total revenue (10k CNY)/yesterday's revenue (yuan)/today's charge and discharge (kWh)/commissioning date)</li> <li>Hidden Stations are not counted in statistics</li> <li>Drop-down list to switch stations, support search. If there are sites in different time zones, the time zone will be marked after the site name.</li> </ul>
Revenue metrics	<ul style="list-style-type: none"> <li>Revenue bar chart: Generate revenue charts based on the total amount of energy storage meter electricity and electricity price (single station configuration)</li> <li>Filter: day, month, year, all (default last 7 days, not including today)</li> </ul>
Electricity index	<ul style="list-style-type: none"> <li>Bar chart: Display the charging and discharging capacity (kWh) of the power station in multiple time dimensions.</li> <li>Filter: day, month, year, all (default last 7 days, not including today)</li> </ul>
System efficiency	<ul style="list-style-type: none"> <li>Metrics: Display single-Station system efficiency metrics</li> <li>Line chart: Display the comprehensive efficiency curve of power stations in multiple time dimensions</li> <li>Filter: day, month, year, all (default last 7 days, not including today)</li> <li>Algorithm:  <math display="block">\text{System efficiency (\%)} = \frac{\text{energy storage discharge}}{\text{energy storage charging}} * 100\%</math> </li> </ul>
Alarm indicator	<ul style="list-style-type: none"> <li>Curve chart: Display the number of alarm statistics for a single station.</li> </ul>

	<ul style="list-style-type: none"> <li>• Pie chart: Display alarm status and alarm level distribution of multi-station equipment</li> <li>• Filter: day, month, year, all (default last 7 days, not including today)</li> </ul>
Time	<ul style="list-style-type: none"> <li>• Click the "day / month / year / all" button in the chart area to switch the time range of the displayed data. You can also customize the switching time range.</li> <li>• The data for this year is displayed monthly starting from January of this year</li> <li>• The monthly data is displayed daily starting from the 1st of this month</li> <li>• All data starts from the time when the stations start operation</li> <li>• Do not include today</li> </ul>

## 6.2 Monitoring - Station (QEMS3.0)

Click to enter a station's EMS system. The following is the V3 version description.

### 6.2.1 Home



Functional modules	Explanation
Overview data	<ul style="list-style-type: none"> <li>• Today charge/discharge: take the meter once data (custom curve can be checked, can not be corrected)</li> <li>• Total Charge/Discharge: Summarize from the Power Report</li> <li>• Yesterday/Total Earnings: Summary from the Earnings Statement</li> <li>• System Efficiency: <math>\text{System Efficiency} = \frac{\text{Total Discharge}}{\text{Total Charge}}</math></li> <li>• Station age: <math>\text{Station age} = \text{current date} - \text{commissioning date}</math></li> <li>• Statistical time: Get it once when you enter the page, and then refresh it automatically every 10s</li> </ul>

Power station information	Click the tab to switch and view the basic information of the power station, including the name, location, commissioning date, installed power, installed capacity, etc. The basic information of the power station can be configured in [System - Station Info MGT].
Energy flow	<ul style="list-style-type: none"> <li>• <b>ESS charging and discharging state:</b> charging/discharging/idle. <ul style="list-style-type: none"> <li>• When all PCS and all branches are in idle state, display idle</li> <li>• When any branch is charging or discharging, combined with the total power judgment, if the total power is positive, it is charging, and if the total power is negative, it is discharging.</li> </ul> </li> <li>• <b>ESS real-time power:</b> Take all energy storage nodes - power reference device 's total power . In case of partial table or device interruption, it will display "-"</li> <li>• <b>SOC:</b> SOC = Total dischargeable capacity of stacks / Total capacity of stacks; when data sources are missing, take the arithmetic mean of the SOC's of all stacks.</li> <li>• <b>Available Cap:</b> take all the battery stack can discharge the total value</li> <li>• <b>Grid Real-time Power</b> take the power of the common connection point -power reference device</li> <li>• <b>Load real-time Power:</b> take the total power of all load nodes-power reference devices .</li> </ul>
Alarm state	<ul style="list-style-type: none"> <li>• <b>CSC (Cloud Station Communication) :</b> normal / abnormal (the cloud cannot communicate with the station EMS normally, usually it is a network problem, which does not affect the normal operation of the station EMS)</li> <li>• <b>Alarm :</b> Normal / Fault / Alarm</li> <li>• <b>Online :</b> Online / Delay (3 minutes without obtaining device data )/ Offline ( 15 minutes without obtaining device data )</li> </ul>
RealTime	<ul style="list-style-type: none"> <li>• Curves are plotted here for each value from 0:00 to 6:00 the next day , with a minimum granularity of 1 minute</li> <li>• The calculation logic of grid power, load power, energy storage power, and SOC is consistent with the logic in energy flow</li> <li>• Strategy Power: Draw a curve based on the power set in the preset strategy template, from the current time to 06:00 the next day</li> <li>• Demand limit: Take the demand protection value of the public connection point at the current time point</li> <li>• Click the "Zoom In" button in the upper right corner of the module, a pop-up window will appear, allowing you to view the curve by day.</li> <li>• Click the "Settings" button in the upper right corner of the module to configure the curves that need to be displayed here.</li> </ul>

## 6.2.2 Monitoring Center

### 6.2.2.1 BESS

Display macro data and station-level parameter curves, including station-level active and reactive power, battery stack SOC curve, today's charge and discharge electricity, etc.

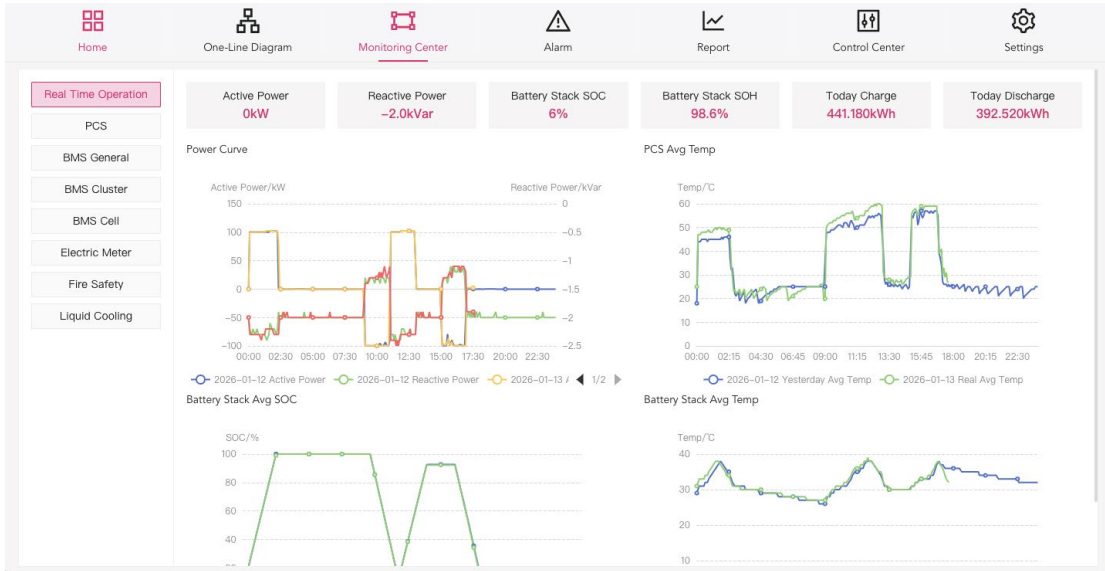

### 6.2.2.2 PCS

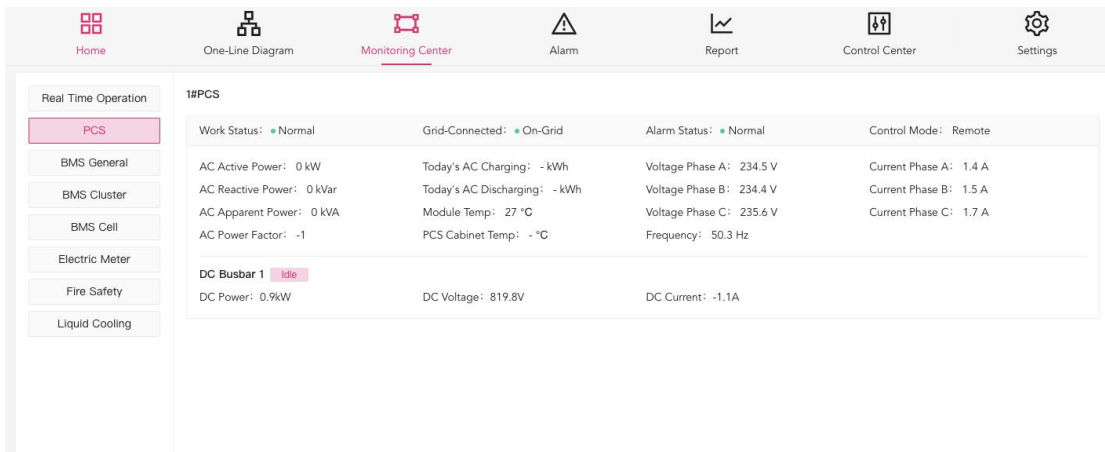

Functional modules	Explanation
Data illustrate	<ul style="list-style-type: none"> <li><b>Run status: (This parameter is a common parameter of the equipment and will not be repeated later)</b> <ul style="list-style-type: none"> <li>normal</li> <li>stop</li> </ul> </li> <li><b>Grid-connected:</b> <ul style="list-style-type: none"> <li>On-grid: When PCS is connected to the city power grid</li> <li>Off-grid: When PCS is disconnected from the urban power grid, it will generally operate in off-grid mode in the microgrid scenario</li> </ul> </li> </ul>

	<ul style="list-style-type: none"> <li>• <b>Alarm status: (This parameter is a common parameter of the device and will not be repeated later)</b> <ul style="list-style-type: none"> <li>• Normal</li> <li>• Alarm</li> <li>• Fault (When there are both alarms and faults, the fault will be displayed first)</li> </ul> </li> <li>• <b>Control mode:</b> <ul style="list-style-type: none"> <li>• Remote mode: log in to the web storage manager, enter the single station monitoring remote control EMS</li> <li>• Local mode: When the EMS is controlled by the screen of the EMS industrial control computer connected to the site locally, the remote/local mode can be switched in the settings. After switching to the local mode, the system will reject the remote control command, and the remote login energy storage manager cannot control EMS</li> </ul> </li> <li>• All other data is collected directly from the device, if not collected it shows "-"</li> </ul>
PCS branch	<ul style="list-style-type: none"> <li>• If there are no branches in PCS, one branch will be displayed by default.</li> <li>• If there are multiple branches, display multiple branches</li> </ul>

### 6.2.2.3 BMS General

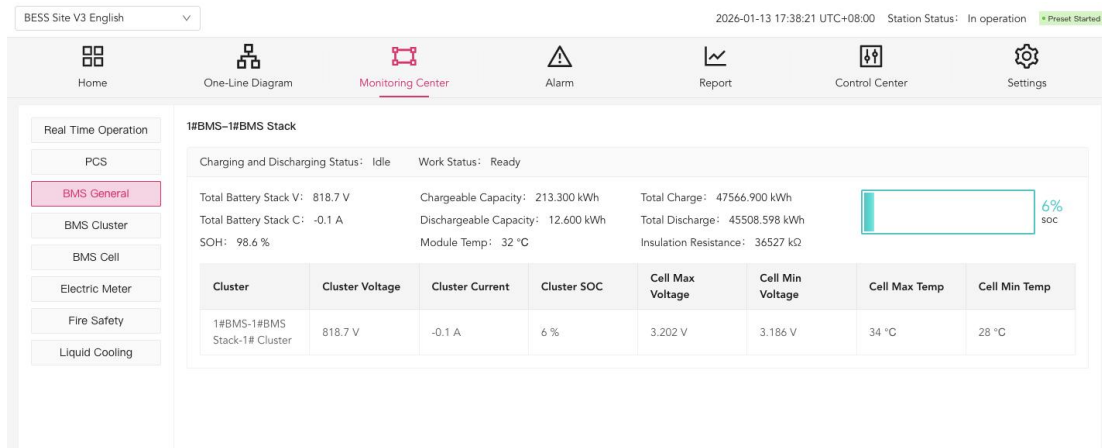

Functional modules	Explanation
Data illustrate	<ul style="list-style-type: none"> <li>• <b>Working status:</b> <ul style="list-style-type: none"> <li>• Charge</li> <li>• Discharge</li> <li>• Idle</li> </ul> </li> <li>• All other data is collected directly from the device. If not collected, it will display "-".</li> </ul>

### 6.2.2.4 BMS Cluster

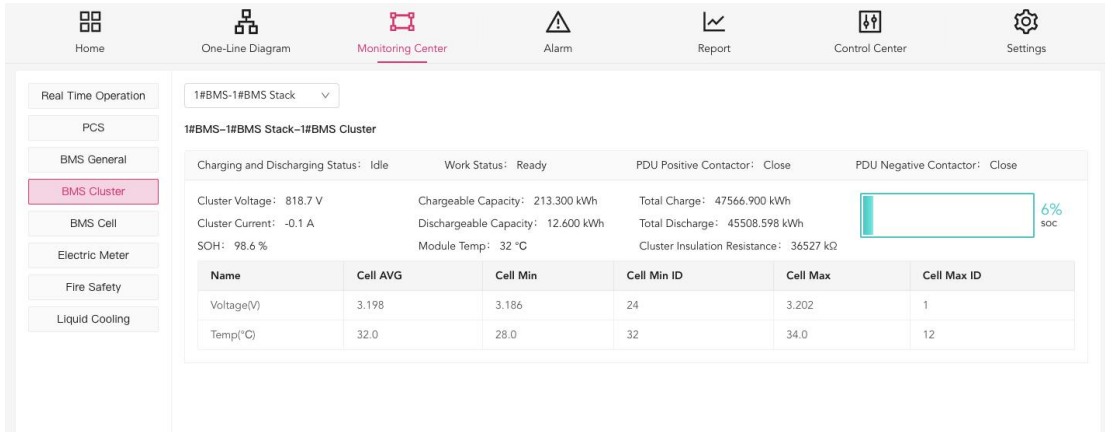

Functional modules	Explanation
Data illustrate	<ul style="list-style-type: none"> <li><b>Working status:</b> <ul style="list-style-type: none"> <li>Charge</li> <li>Discharge</li> <li>Idle</li> </ul> </li> <li><b>Main Positive Contactor:</b> <ul style="list-style-type: none"> <li>Closed (usually the contactor state of multiple clusters is closed and opened simultaneously)</li> <li>Break</li> </ul> </li> <li><b>Main Negative Contactor:</b> <ul style="list-style-type: none"> <li>Closed</li> <li>Break</li> </ul> </li> <li>All other data is collected directly from the device, if not collected it shows "-"</li> </ul>
Switching device	<ul style="list-style-type: none"> <li>Click the drop-down list to switch battery clusters and view battery cluster data under different stacks.</li> </ul>

### 6.2.2.5 BMS Cell

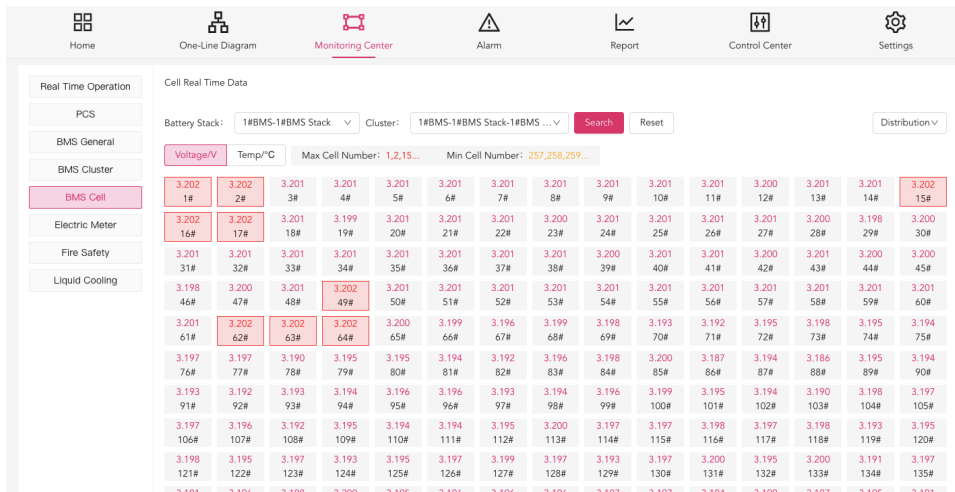

Functional modules	Explanation
Switching device	<ul style="list-style-type: none"> <li>Click the drop-down list in the upper left corner to switch battery clusters and view the data of cells under different battery clusters.</li> <li>The first battery stack and the first battery cluster are selected by default</li> </ul>
View switching	<ul style="list-style-type: none"> <li>Click the button in the upper-right corner to switch between displaying the data as a distribution chart, table, or bar chart. The bar chart supports X-axis and Y-axis scaling.</li> </ul>
Parameter switching	<ul style="list-style-type: none"> <li>Click the button in the upper left corner to switch and view the voltage, temperature, SOC (if not collected, this parameter will not be displayed), and SOH (if not collected, this parameter will not be displayed) of each cell under the battery cluster.</li> </ul>
Data illustrate	<ul style="list-style-type: none"> <li>Display the real-time voltage, temperature, SOC, and SOH parameters corresponding to each battery cell</li> <li>The number of voltage points is displayed according to the number of cells configured during commissioning; the number of temperature points is displayed according to the number of temperature measurement points configured during commissioning, which may differ from the number of cells; SOC and SOH are not displayed when not collected.</li> </ul>

### 6.2.2.6 Electric Meter

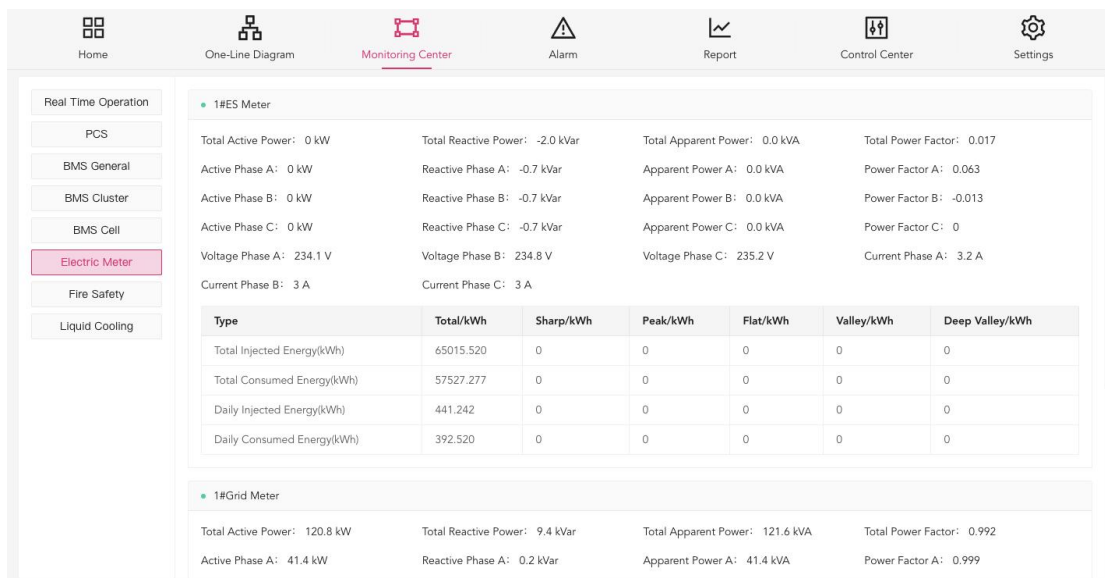

All data is collected directly from the device. If not collected, it will display "-".

### 6.2.2.7 Fire Safety

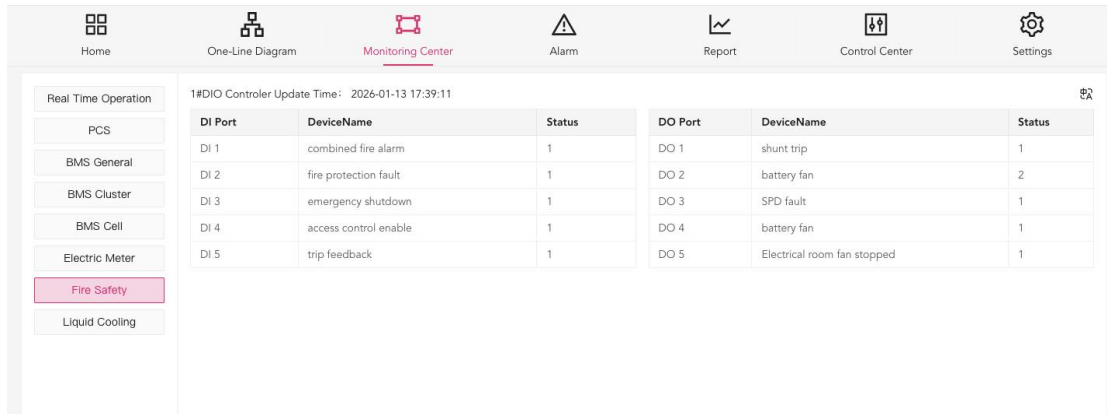

#### The Fire Safety page contains equipment:

- IO controller
  - Support to display the status of DI and DO ports of the IO controller. The DI and DO status names can be modified by finding the corresponding IO controller in [System - Device MGT].
- Various types of sensors
- Measurement and control device (Switch)
  - All parameters of the measurement and control device are manually configured by the delivery personnel in the [configuration file], so the parameter display and control of the measurement and control device have high flexibility
  - Click on the [Config] on the right side of the measurement and control device to write the measurement and control point once

All data is collected directly from the device, if not collected it shows "-"

### 6.2.2.8 Liquid Cooling

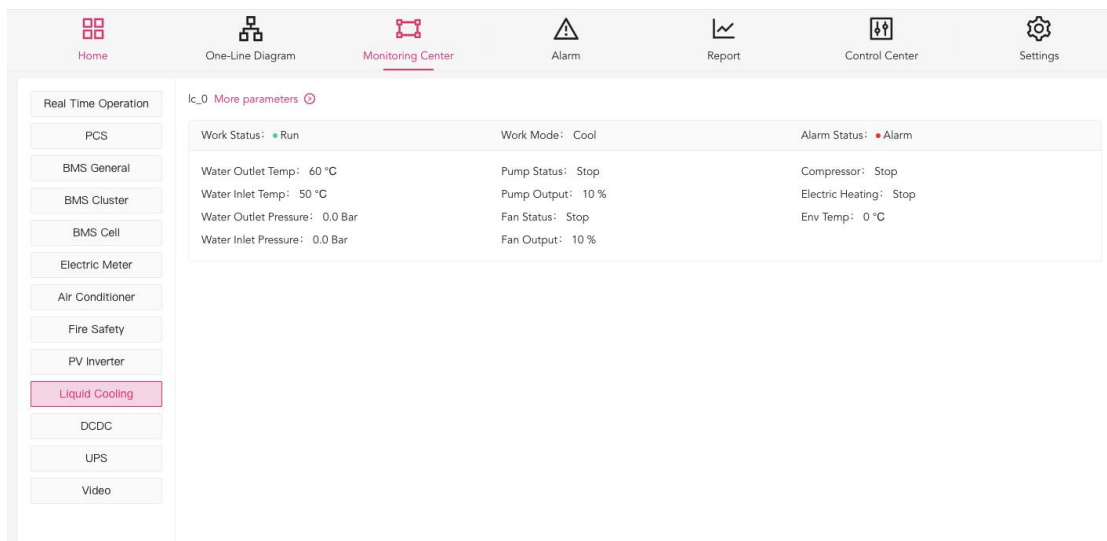

All data is collected directly from the device. If not collected, it will display "-".

### 6.2.3 Alarm

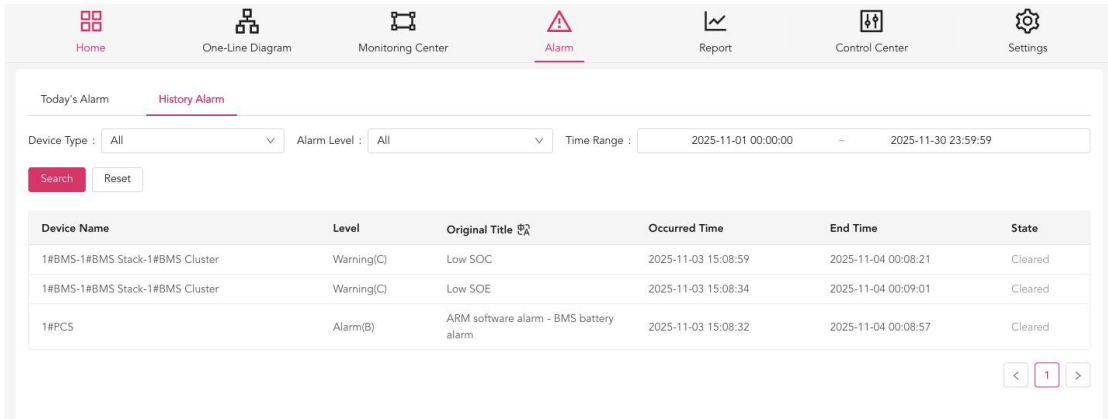

- **Today's alarm:** Display the alarm that is currently occurring or the end time of the alarm is today.
- **History alarm:** Display alarms that have ended and ended before today. Historical alarms can be queried by time.

On the Alarm interface, click the translation button next to the Original Title to select a language for AI translation.

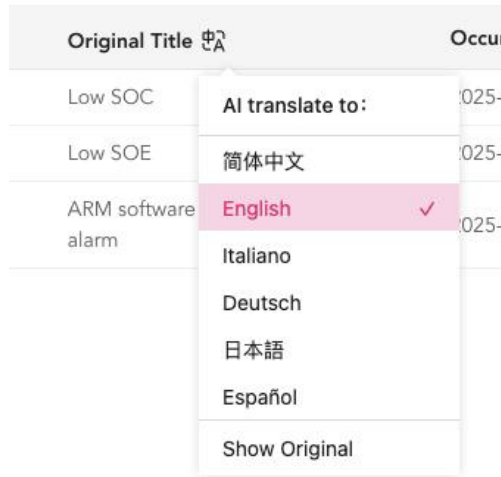

Due to technical limitations, the selection will not be remembered, and users will need to reselect the language when entering the Alarm page again after leaving it.

Access AI interfaces online, performance will be affected by network speed.

## 6.2.4 Report

### 6.2.4.1 Overview

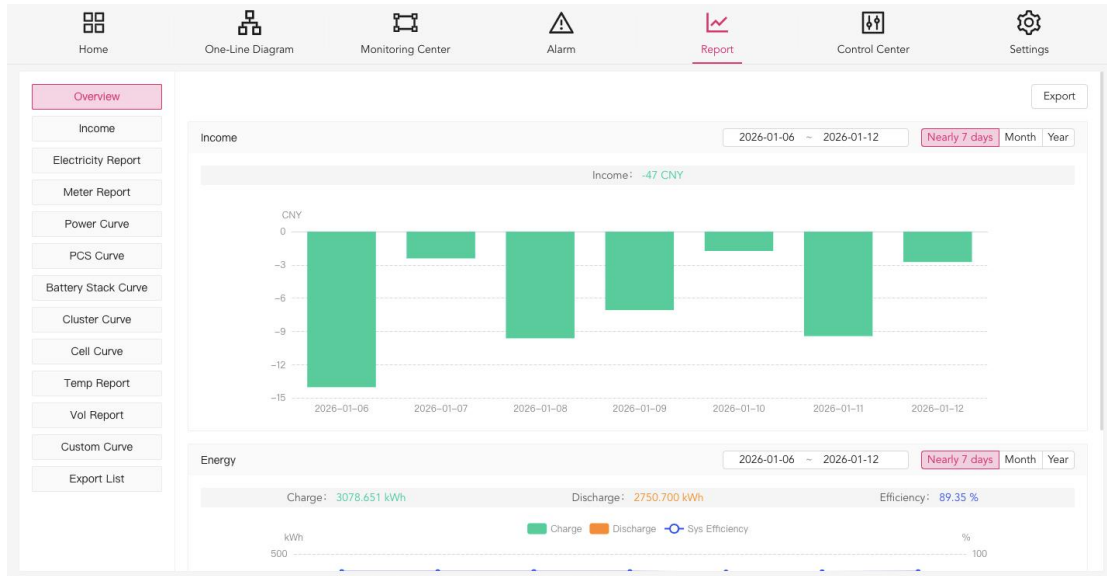

Functional modules	Explanation
Energy storage revenue metric	<ul style="list-style-type: none"> <li>The default query is the last 7 days. You can click to quickly switch between current month and current year data, or click the date range checkbox to manually select.</li> <li>The bar chart in the daily earnings value in the earnings report</li> <li>Top Total Income = Daily Income During Select Date Sum</li> </ul>
Energy storage quantity index	<ul style="list-style-type: none"> <li>The default query is the last 7 days. You can click to quickly switch between current month and current year data, or click the date range checkbox to manually select.</li> <li>The daily electricity value in the bar chart is in the electricity report</li> <li>Efficiency ( %) = Discharge/Charge</li> </ul>

6.2.4.2 Income

Date	Charging Cost(EUR)						Discharge Revenue(EUR)						Income(EUR)
	Sharp	Peak	Flat	Valley	Deep Valley	Total	Sharp	Peak	Flat	Valley	Deep Valley	Total	
2025-11-01	0	0	0	0.656	0	0.656	0	0	0	0	0	0	-0.656
2025-11-02	0	0	0	0	0	0	0	0	0	0	0	0	0
2025-11-03	0	0	0	0	0	0	0	0	0	0	0	0	0
2025-11-04	0	0	0	0	0	0	0	0	0	0	0	0	0
2025-11-05	0	0	0	0	0	0	0	0	0	0	0	0	0
2025-11-06	557.383	1179.609	1.289	496.969	0	2235.250	10672.758	284.988	98.164	140.086	0	11195.996	8960.746
2025-11-07	404.359	1375.563	0.633	1572.344	0	3352.898	11401.606	241.320	98.195	321.660	0	12062.781	8709.883
2025-11-08	405.016	1375.078	1.078	1573	0	3354.172	11416.453	241.148	98.125	321.531	0	12077.258	8723.086

- All meters and individual meters can be selected
- Data for the previous day is updated daily at 00:30 in the time zone corresponding to the site
- Calculation formula:
  - Charging cost (sharp, peak, flat, valley, deep valley) = time period electricity x time period electricity price
  - Discharge income (sharp, peak, flat, valley, deep valley) = period electricity x period electricity price
  - Actual income = discharge income (daily summary) - charging cost (daily summary)
- If the site has enabled the "day-ahead price", the page is as follows:

Date	Charging Cost(CNY)	Discharge Revenue(CNY)	Income(CNY)
2026-01-01	15.2	11.8	-3.4
2026-01-02	34.2	28.4	-5.8
2026-01-03	39.3	33.1	-6.1
2026-01-04	35.4	22.8	-12.6
2026-01-05	30.8	32.9	2.1
2026-01-06	41.3	27.2	-14.0
2026-01-07	41.5	39.0	-2.4
2026-01-08	45.4	35.8	-9.6
2026-01-09	27.6	20.6	-7.1
2026-01-10	30.1	28.4	-1.7
2026-01-11	42.8	33.3	-9.4
2026-01-12	36.3	33.6	-2.7

- Charging cost, or discharge income = electricity per 15 minutes x electricity price per 15 minutes
- Actual revenue = discharge income - charging cost

### 6.2.4.3 Power Curve



- Grid power = the total active power of the meters corresponding to all transformer nodes directly connected to the grid
- Load power = the total active power of the load table corresponding to all load nodes
- Power Active = Energy storage power = the total active power of the energy storage meter corresponding to all energy storage nodes; the sum of the PCS active power corresponding to all energy storage nodes
- PV power = the total active power of all PV nodes corresponding to the photovoltaic meter
- SOC = Total dischargeable capacity of stacks / Total capacity of stacks; when data sources are missing, take the arithmetic mean of the SOC of all stacks.

### 6.2.4.4 PCS Curve



- Compare: Display the power, temperature, three-phase voltage, and three-phase current curves of PCS equipment in the past 2 days, and switch devices and time periods to view.
- Trend: Display the power, temperature, three-phase voltage, and three-phase current curves of PCS equipment in the last 7 days, and switch devices and time periods to view.

### 6.2.4.5 Battery Stack Curve

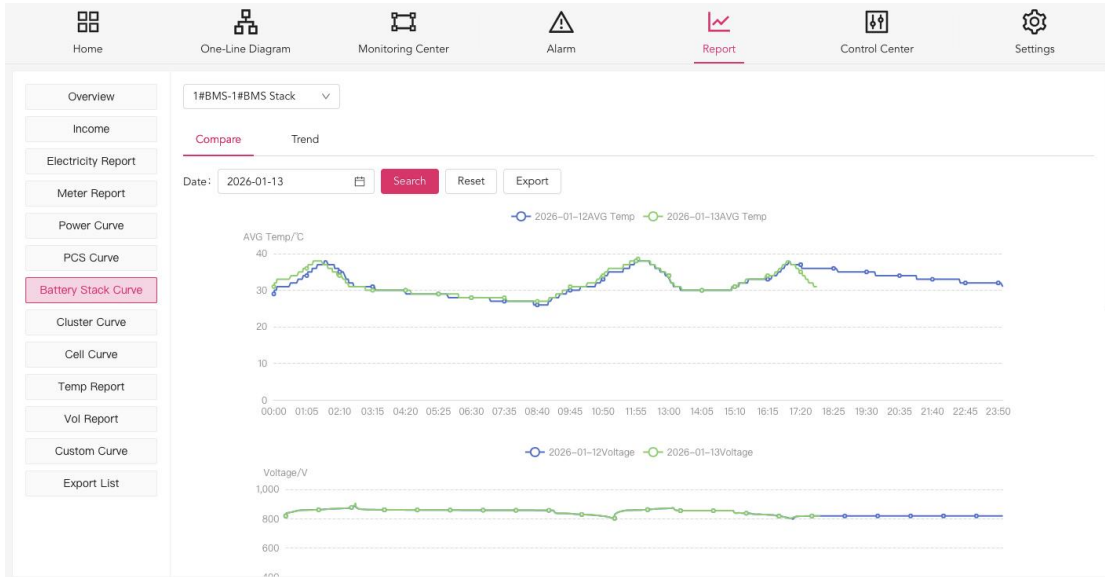

- **Compare:** Display the temperature, voltage, current, and SOC curves of the battery stack in the last 2 days, and switch devices and time periods to view.
- **Trend:** Display the temperature, voltage, current, and SOC curves of the battery stack in the last 7 days, and switch devices and time periods to view.

### 6.2.4.6 Cell Curve



Display the temperature, voltage, and SOC curves of a single battery in the past 7 days, and switch devices and time periods to view.

### 6.2.4.7 Custom Curve

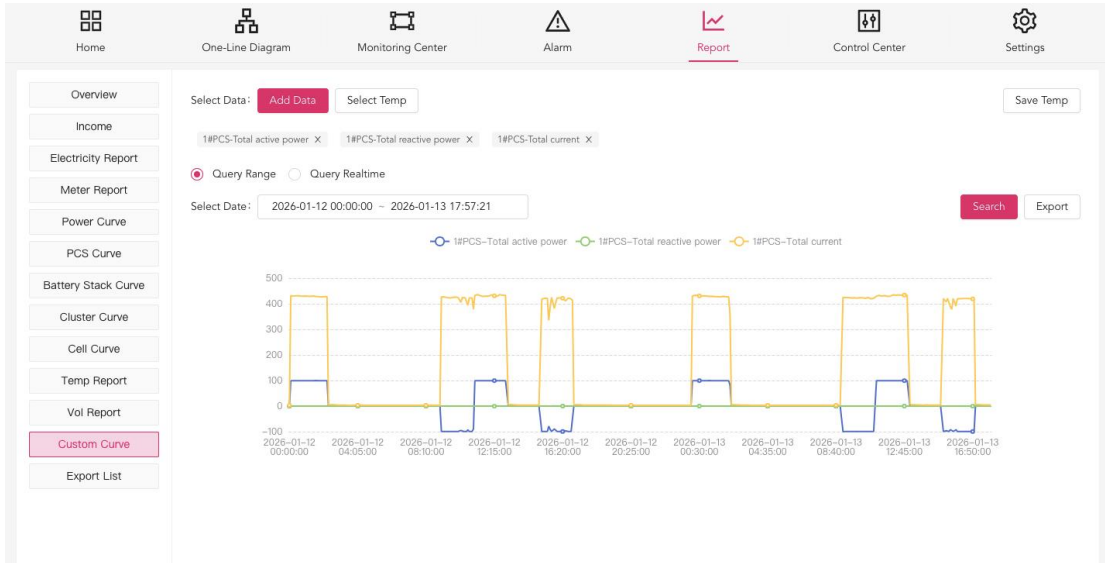

- Add data: Click the button to bring up the sidebar, select the data you want to query in the sidebar (select up to 10 items), and click "Confirm" after selection.

- Save and select templates: After selecting the data, click "Save Template" and enter the template name. The next time you need to query the same data, click the "Select Template" button to easily call it up without having to search and select data items again.

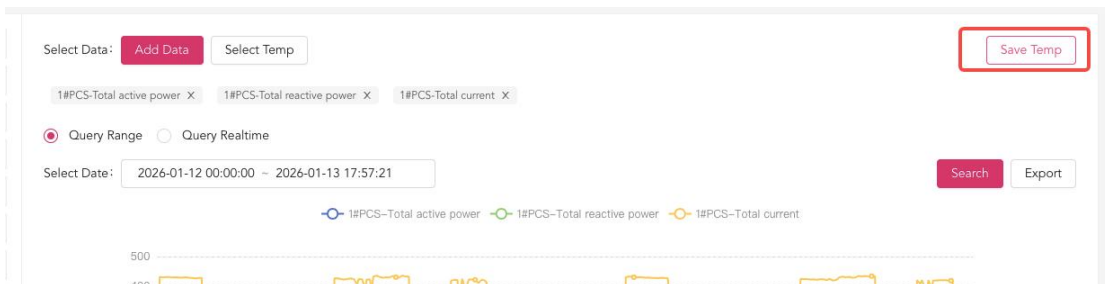

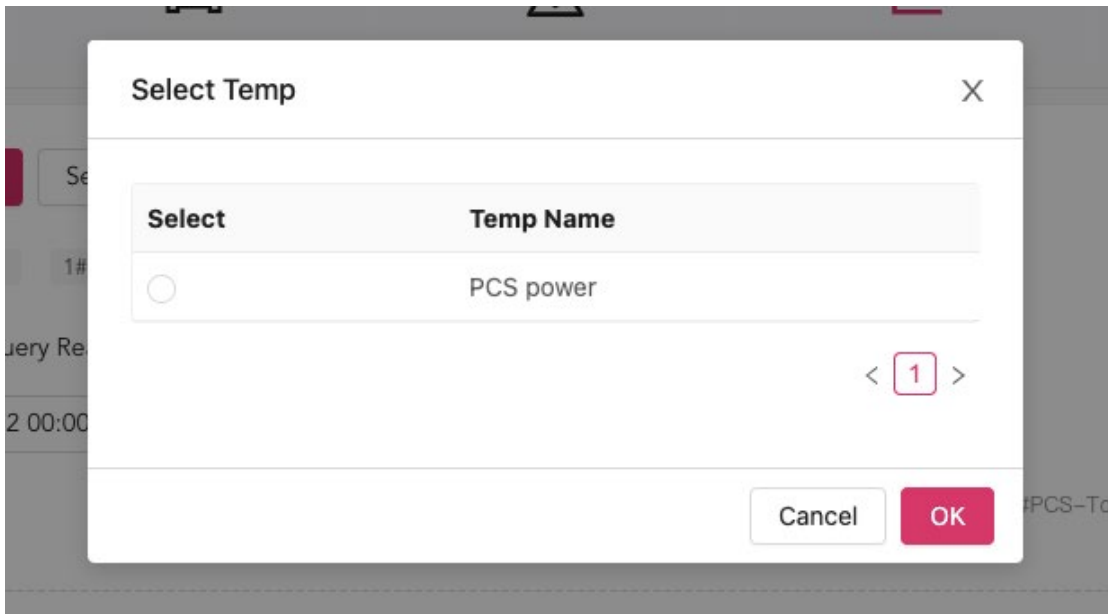

- Query range: Select "Query range", select the time range to be queried in the "Select date" box (can be selected to seconds); or directly click "query realtime", the data from 0:00 today to the present moment will be queried by default.

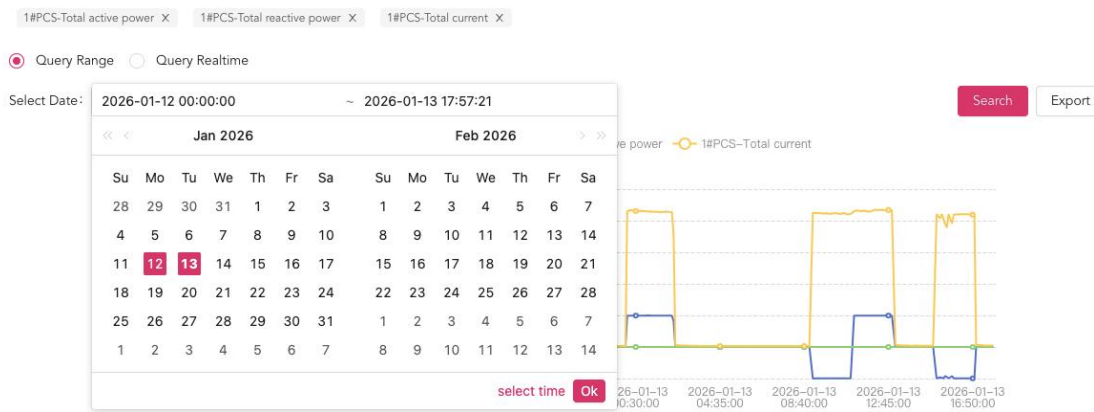

- Click the "Search" button to start the query; click the "Export" button to select the sampling frequency of the data to be exported.

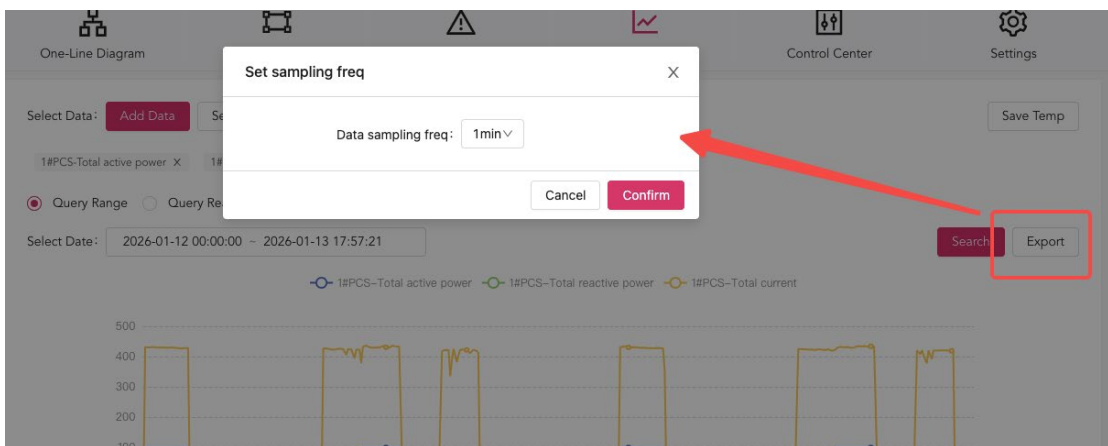

Export limit: Full single export supports up to 12h.

The export here is asynchronous, you need to go to the "Export List" to query the export results.

## 6.2.5 Control

When entering the " Control Center " module, for security reasons, you need to enter the password. If the password is correct, you can enter.

The password is sent by the platform along with the account password. If you are unsure of the password, please consult your platform administrator or our business personnel.

This password can be managed on the [Settings - Second Password] page.

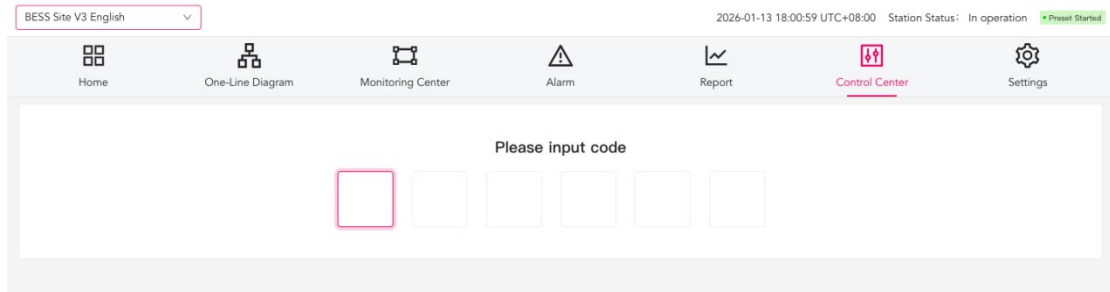

## 6.2.6 System

### 6.2.6.1 Station info MGT

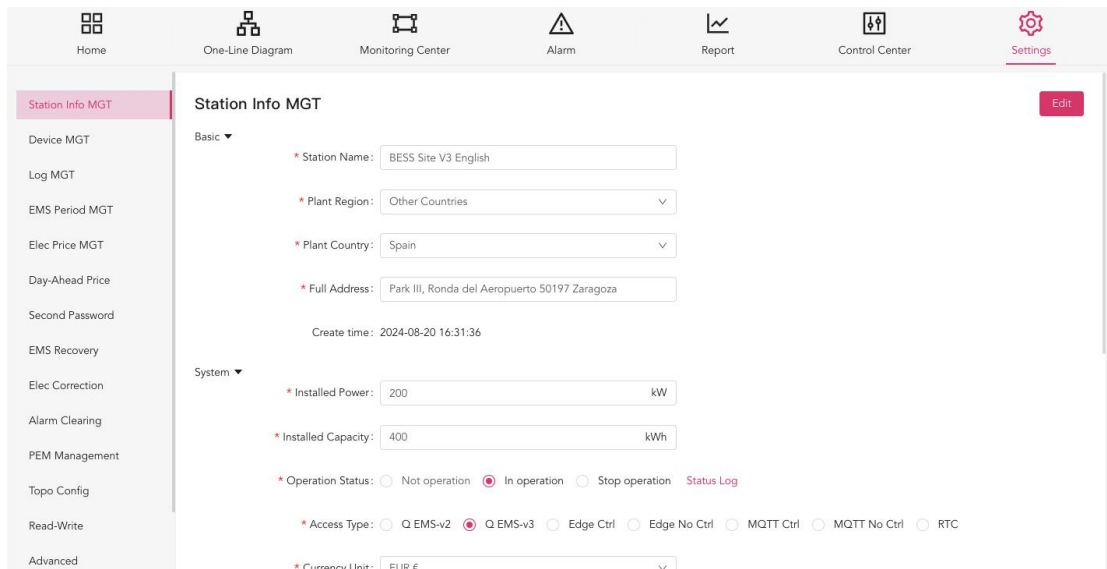

To view and edit the information of the station.

To edit Modbus Server Connection, scroll down to 'More' and click to expand it, you can see the 'Modbus Server Connection' input box. Enter the IP address.

Remember to scroll up and click 'Save'.

Date of actual operation

\* Access Time:  

Please select the date when the power station data is actually connected to the platform. Data platforms before this date will not be displayed

More ▼

Modbus Server Connection:

Grid-Vol:  kV

Master Provider:

EPC Provider:

Opera Provider:

### 6.2.6.2 Device MGT

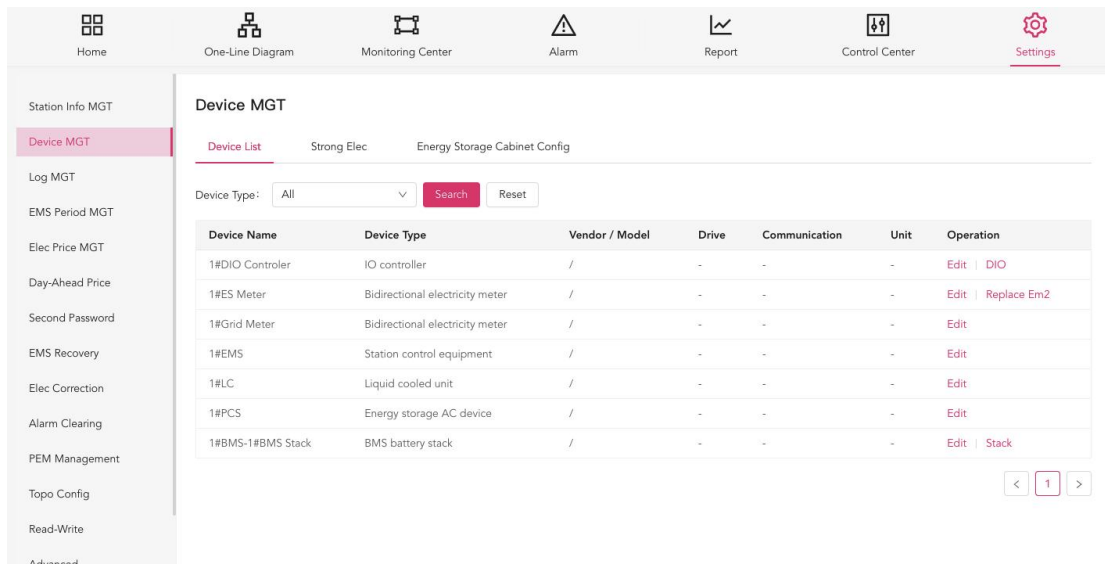

The screenshot shows the 'Device MGT' interface. At the top, there is a navigation bar with icons for Home, One-Line Diagram, Monitoring Center, Alarm, Report, Control Center, and Settings. Below this is a sidebar menu with options like Station Info MGT, Device MGT (highlighted), Log MGT, EMS Period MGT, Elec Price MGT, Day-Ahead Price, Second Password, EMS Recovery, Elec Correction, Alarm Clearing, PEM Management, Topo Config, Read-Write, and Advanced. The main content area is titled 'Device MGT' and has tabs for 'Device List', 'Strong Elec', and 'Energy Storage Cabinet Config'. Under 'Device List', there is a 'Device Type' dropdown set to 'All', a 'Search' button, and a 'Reset' button. Below this is a table with the following data:

Device Name	Device Type	Vendor / Model	Drive	Communication	Unit	Operation
1#DIO Controller	IO controller	/	-	-	-	Edit   DIO
1#ES Meter	Bidirectional electricity meter	/	-	-	-	Edit   Replace Em2
1#Grid Meter	Bidirectional electricity meter	/	-	-	-	Edit
1#EMS	Station control equipment	/	-	-	-	Edit
1#LC	Liquid cooled unit	/	-	-	-	Edit
1#PCS	Energy storage AC device	/	-	-	-	Edit
1#BMS-1#BMS Stack	BMS battery stack	/	-	-	-	Edit   Stack

At the bottom right of the table, there are navigation buttons: '< 1 >'. The 'Settings' icon in the top right is highlighted in red.

Check the equipment connected to the power station and modify the information of the equipment . (Do not modify it at will!!!!)

Partial Function Description:

Functional modules	Explanation
Modify device name	Click "Edit", a pop-up window will appear, you can see the line "Device Name", enter and save to modify.

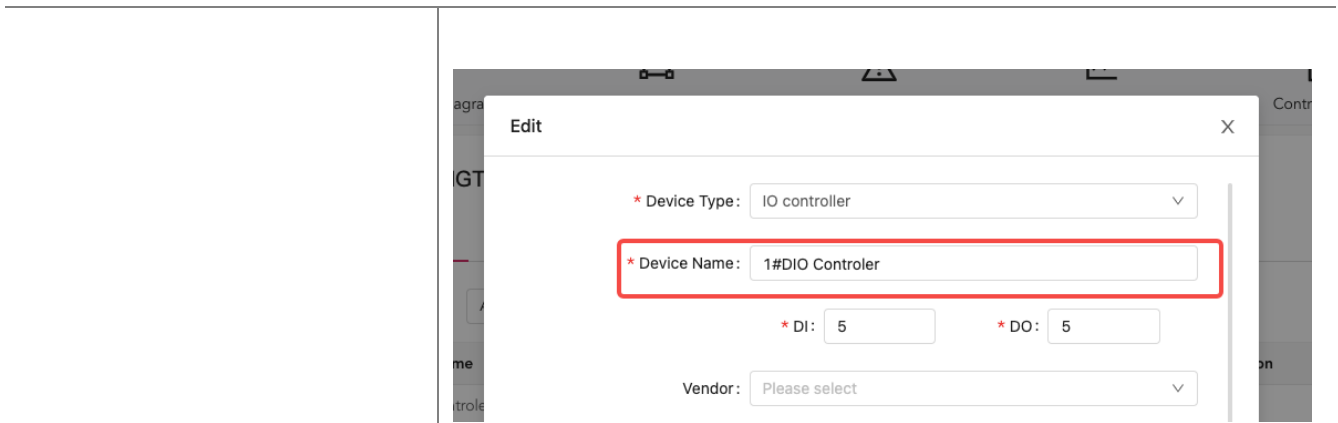

Replace the meter

In the operation column of the meter equipment, there is a "Replace Em2" button.

Click to bring up the pop-up window. The system will automatically create a new meter and activate the new meter at 0:00 of the meter replacement time. After the old meter is discarded, the device data is locked and will not be deleted.

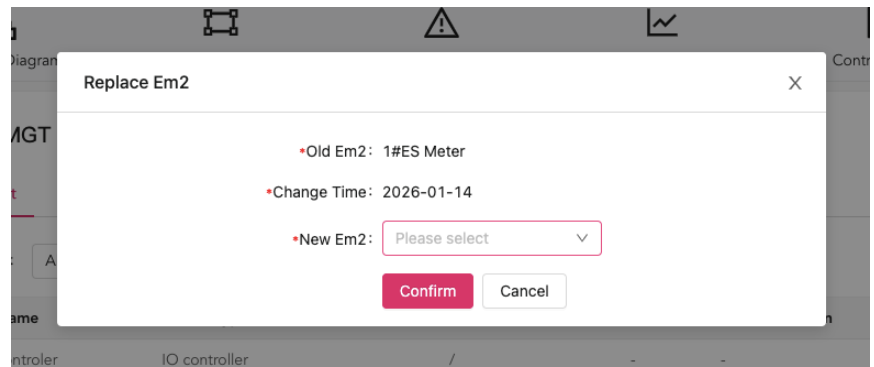

DIO information

In the operation column of the IO controller device, there is a "DIO" button.

Click to bring up the pop-up window, fill in the device name and remote message status meaning of each port connected to the device. Click OK to save. The filling result will take effect when the corresponding IO controller device is displayed on the [Device - Fire Safety] page.

DIO
X

DIO Port	Device Name	Remote msg status = 0	Remote msg status = 1
DI1	combined fire alarm	<input type="text" value="1"/>	<input type="text" value="2"/>
DI2	fire protection fault	<input type="text" value="1"/>	<input type="text" value="2"/>
DI3	emergency shutdown	<input type="text" value="1"/>	<input type="text" value="2"/>
DI4	access control enat	<input type="text" value="1"/>	<input type="text" value="2"/>
DI5	trip feedback	<input type="text" value="1"/>	<input type="text" value="2"/>
DO1	shunt trip	<input type="text" value="1"/>	<input type="text" value="2"/>
DO2	battery fan	<input type="text" value="1"/>	<input type="text" value="2"/>
DO3	SPD fault	<input type="text" value="1"/>	<input type="text" value="2"/>
DO4	battery fan	<input type="text" value="1"/>	<input type="text" value="2"/>
DO5	Electrical room fan :	<input type="text" value="1"/>	<input type="text" value="2"/>

- Station Info MGT
- Device MGT
- Log MGT
- EMS Period MGT
- Elec Price MGT
- Day-Ahead Price
- Second Password
- EMS Recovery
- Elec Correction
- Alarm Clearing
- PEM Management
- Topo Config

### Device MGT

Device List
Strong Elec
Energy Storage Cabinet Config

After filling in all the configurations, click Enter to make the configurations take effect.

Node
Table
Topo

Type:

Name	Type	Power Refer	Operation
POI	Public Point	1#Grid Meter	<a href="#">Edit</a>
1#Transformer	Transformer	1#Grid Meter	<a href="#">Delete</a>   <a href="#">Edit</a>
1#Power	Power Node	1#ES Meter	<a href="#">Delete</a>   <a href="#">Edit</a>
1#Load	Load Node	1#ES Meter	<a href="#">Delete</a>   <a href="#">Edit</a>

Check the strong electric structure of the power station and modify the parameters and relationships of the strong electric structure . (Please do not modify it at will!!!)

Strong electrical structure relationship and parameters are used for EMS strategy planning and protection.

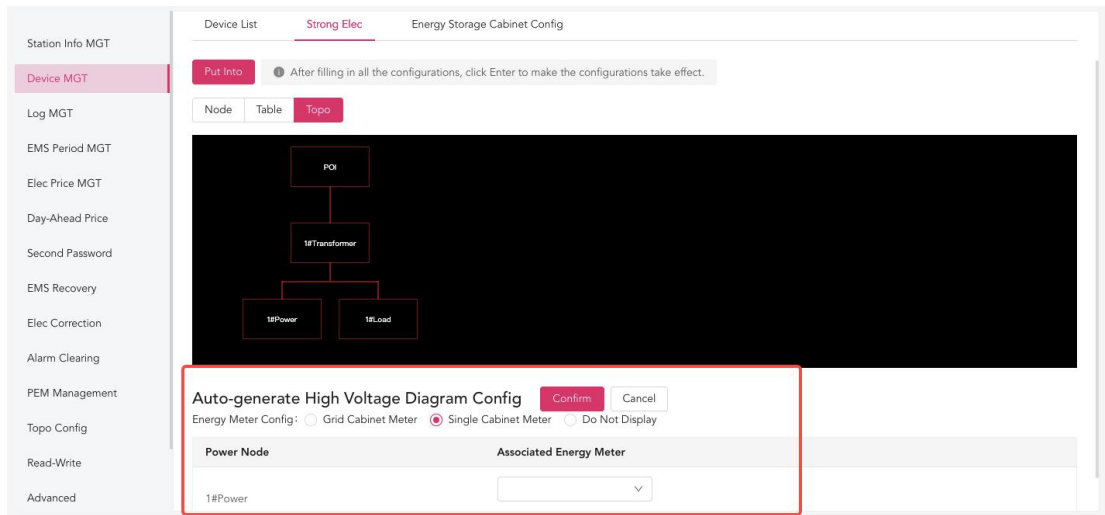

On Strong Elec page, you can configure whether to display the energy storage meter on the [One-Line Diagram] page and which energy storage meter to associate.

When the Energy Meter Config is selected as "Grid Cabinet Meter", it means that multiple energy storage nodes (energy storage cabinets) under a transformer are connected to the same grid-connected cabinet and share the same energy storage meter;

When the Energy Meter Config is selected as "Single Cabinet Meter", it means that multiple energy storage nodes (energy storage cabinets) under one transformer each use an independent meter.

### 6.2.6.3 Log MGT

View operation logs, dynamic logs, and EMS logs

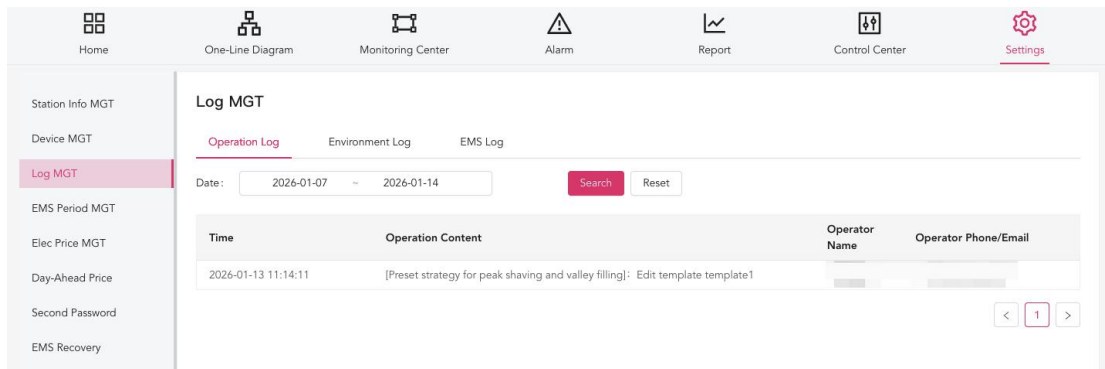

### 6.2.6.4 EMS Period MGT

When the meter time-sharing source is EMS time period management, you need to enable the sharp, peak, flat, valley, and deep valley rules for setting time periods . Click the "Period MGT" tab to configure it, and the configuration method is similar to strategy configuration.

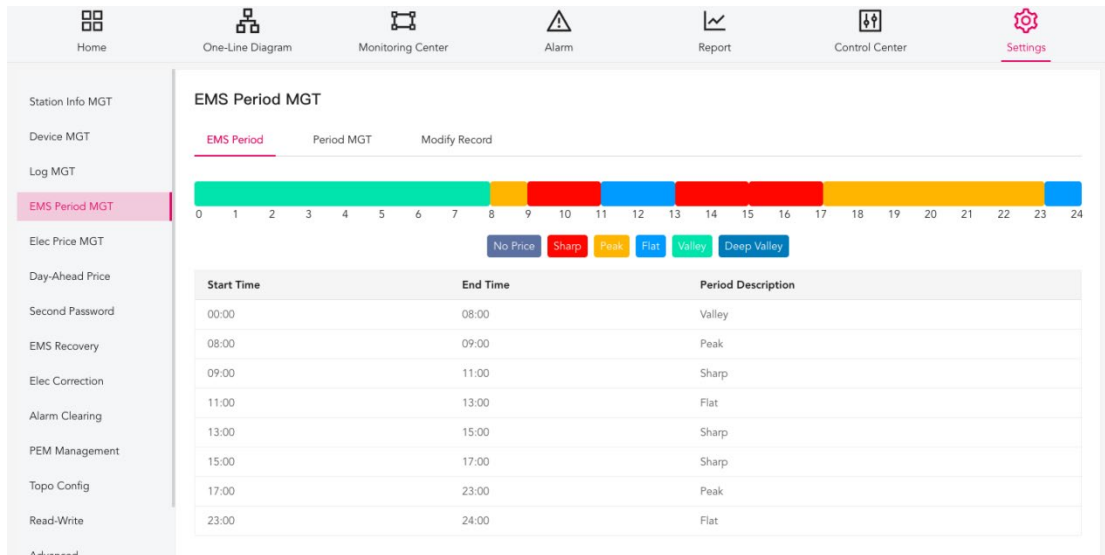

### 6.2.6.5 Elec price MGT

Peak and valley electricity prices are set here.

- Used to set monthly and daily electricity prices. Electricity prices and electricity consumption are involved in the calculation, and the final income of station charging and discharging is obtained
- When setting the daily electricity price, it is preferentially executed according to the daily electricity price.

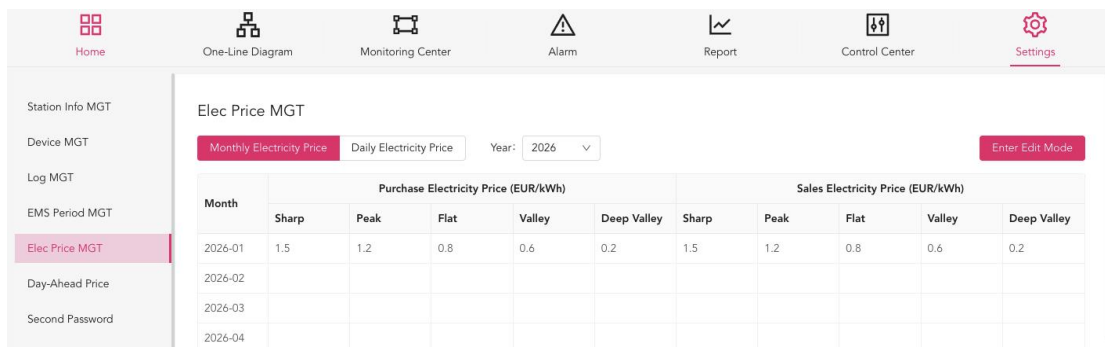

### 6.2.6.6 Day-ahead price

To use this feature, please consult a technician for configuration.

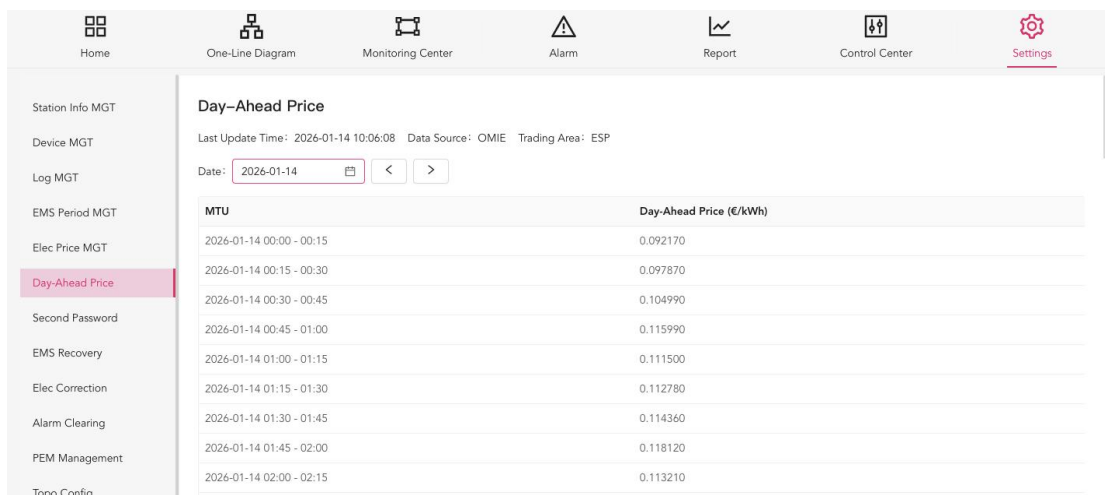

- Usually used in the day-ahead electricity trading market in the European region.

- Support automatic retrieval of specific country's daily electricity prices from the relevant interface of the European energy trading website. The interface will indicate the data source and region. The above picture is the ESP (Spain) electricity price obtained from the OMIE website.
- Price granularity is 15 minutes.

### 6.2.6.7 Topo Config

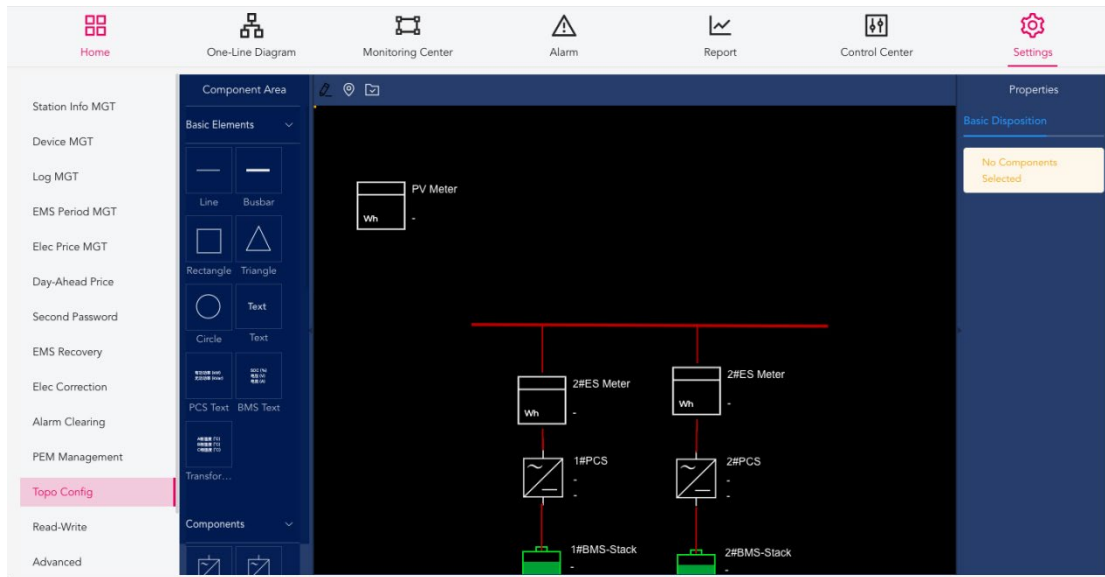

Operation	Operation mode
Move the canvas	Drag and hold the right mouse button on the canvas.
Canvas Zoom	Mouse scroll wheel zoom.
Add primitive	Press and hold the icon on the left side of the mouse button and drag it into the canvas.
Selected primitive	<p>Single choice: Click on the element.</p> <p>Multiple selection: Press and hold Ctrl to select multiple graphics, or hold down the left mouse button to box select the needed graphics.</p> <p>Select all: ctrl + A</p> <p>The selected element will display a turquoise border, and the selected line will have a shadow.</p>
Move primitive	After selecting the element, press and drag. A white auxiliary line will appear on the element to assist in movement and alignment.
Draw connecting lines	<p>After selecting the graphic element, four semi-transparent white dots will appear on the top, bottom, left, and right sides of the graphic element.</p> <p>Hold down the mouse from the dots and connect to the dots of other graphic elements to complete the connection line drawing. The drawn lines will automatically attach to the graphic element and follow its movement.</p>



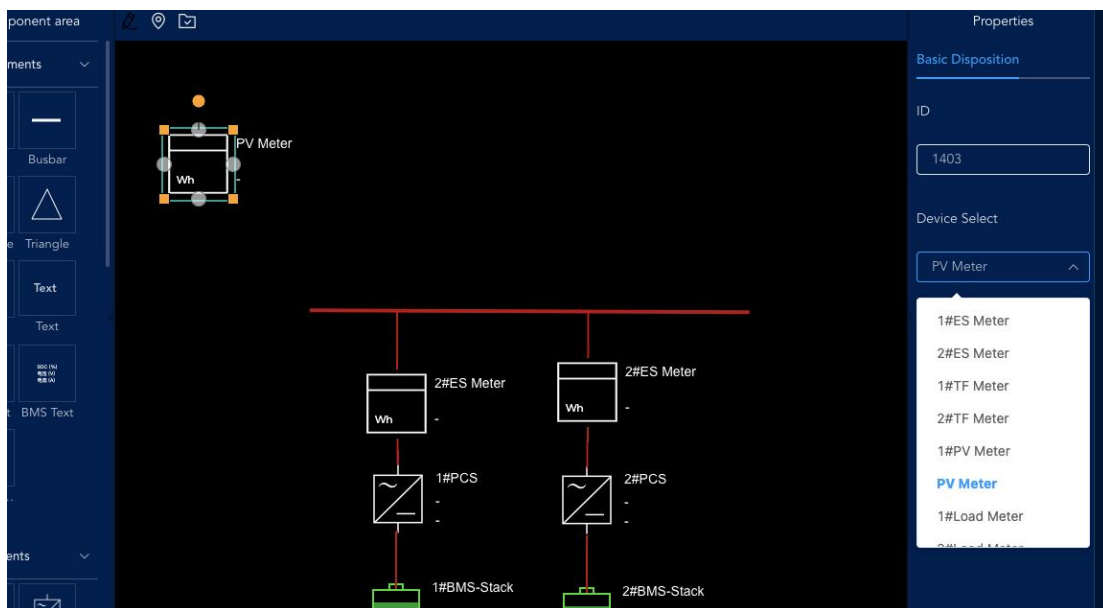

	For triangle elements, if you want to connect to the center of the bottom edge, you need to connect lines from other elements to the triangle
Shear primitive	After selecting the element, right-click on the selected element and select Copy, or Ctrl + X
Duplicate primitive	After selecting the element, right-click on the selected element and select Copy, or Ctrl + C
Paste primitive	Right-click on a blank space on the canvas and select Paste, or ctrl + V <b>Note :</b> The pasted primitive will appear in the position where the mouse hovers by default. Before pasting, it is recommended to move the mouse to the blank area of the canvas.
Delete primitive	After selecting the element, right-click on the selected element and select Delete, or Delete.
Undo previous step	ctrl+Z
Adjust display level	After selecting the element, right-click the element and select Move up one layer/Move down one layer/Move to top layer/Move to bottom layer. After the hierarchy is moved, the relationship between the stacked elements covering each other will change.
Align	After selecting multiple elements, right-click the element and select align left/align right/align top/align bottom.

After selecting some elements, a drop-down box for device selection will appear in the property area on the right.



Select the device that this primitive needs from the drop-down box, and click once in the blank space of the canvas to complete the selection. The device name will appear next to the device primitive.

The operation buttons in the upper left corner of the canvas are described as follows:

Button	Name	Explanation
 	Enable connection mode/exit connection mode	<p>In the connection mode, operations such as primitive movement and connection can be performed.</p> <p>After exiting the connection mode, you can no longer edit the primitive, only drag and zoom the canvas.</p> <p>If you encounter a situation where you cannot edit, please check this button.</p>
	Center the screen	<p>After clicking, the canvas returns to the center of all components.</p> <p><b>Note :</b> This operation will not adjust the zoom, if you find that you still can't find the drawn component after returning to the center, please try to scroll the wheel to zoom in and click again.</p>
	Save	<p>After the drawing is complete, click this button to save.</p> <p><b>Note :</b> The product currently does not have the function of saving drafts, <b>please remember to save manually</b> when editing.</p>

### 6.2.6.8 Read-Write

When entering the "Read-Write" module, for security reasons, you need to enter the password. If the password is correct, you can enter.

The password is sent by the platform along with the account password. If you are unsure of the password, please consult your platform administrator or our business personnel.

This password can be managed on the [Settings - Second Password] page.

**During strategy issuance and dynamic environment protection processes, the program will automatically write device points. Skipping the normal control program and directly writing device points may pose risks, so please operate with caution.**

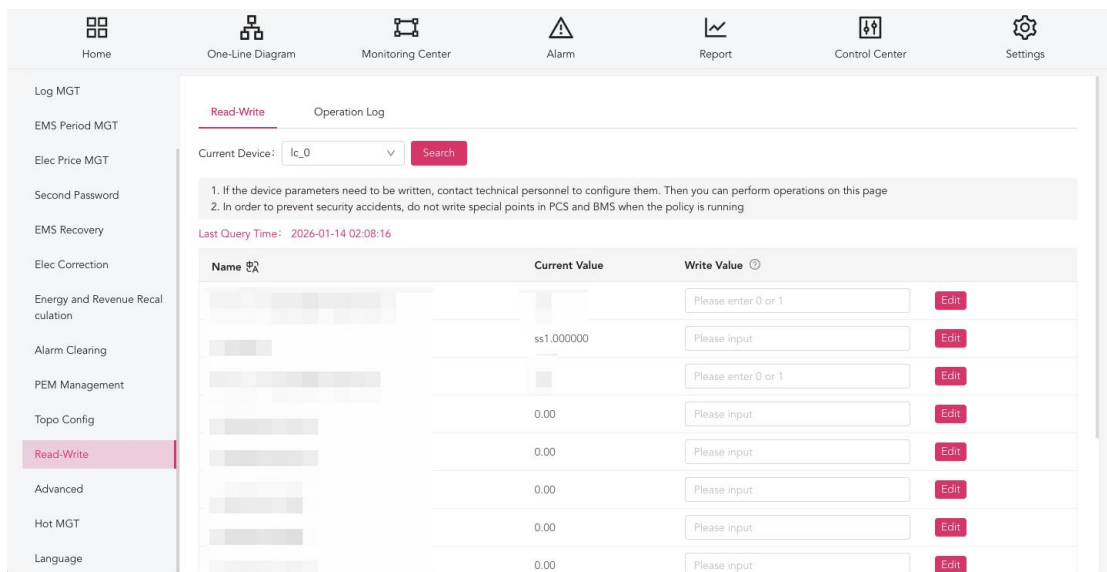

On the page, click the dropdown box to select the device to write to; click "Edit" at the end of the parameter row to perform the write operation.

After performing a write operation, please wait a few minutes and click "Search" again. If the current value is updated to the value just written, it indicates that the write operation was successful.

## 6.3 Station end HMI usage instructions

### 1) Log In.

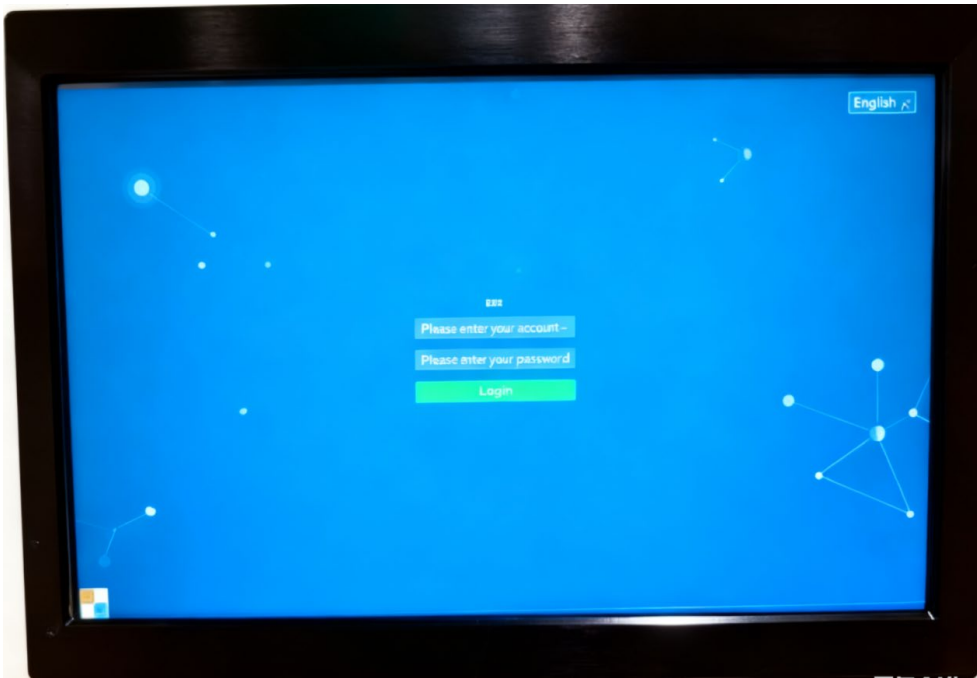

Enter the account name/password to log in, and you can switch languages in the upper right corner.

Factory default account name: admin

Factory default password: admin

### 2) Mode switching

By default, the station is in "remote" mode. In remote mode, EMS runs according to the site configuration of the cloud platform and accepts control from the cloud.



Click the upper right corner to quickly enter the [Mode Management] page, which can switch the site to "local" mode, not accept the control of the cloud platform, and carry out policy control and other Settings independently for a single site.

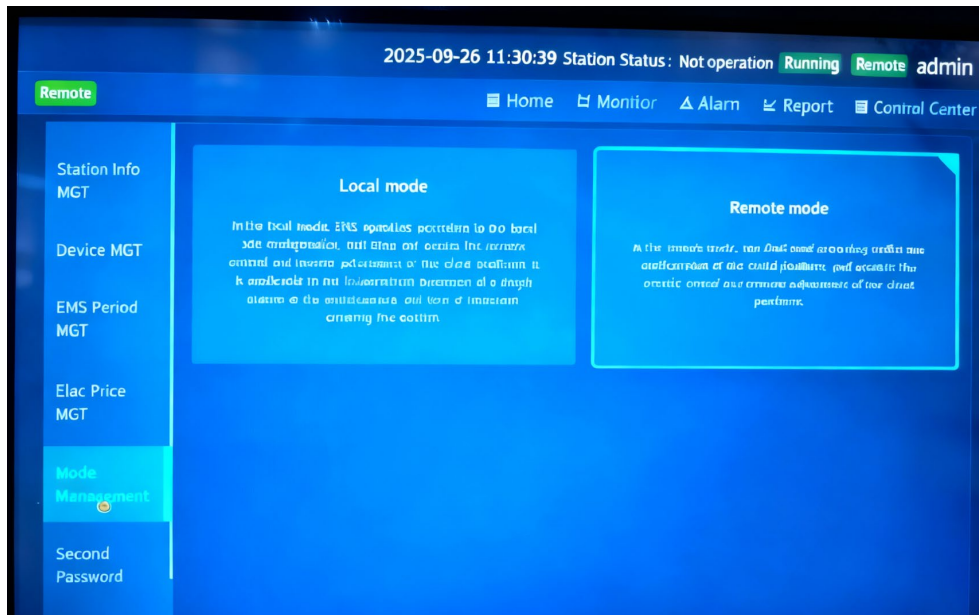

### 3) Home page

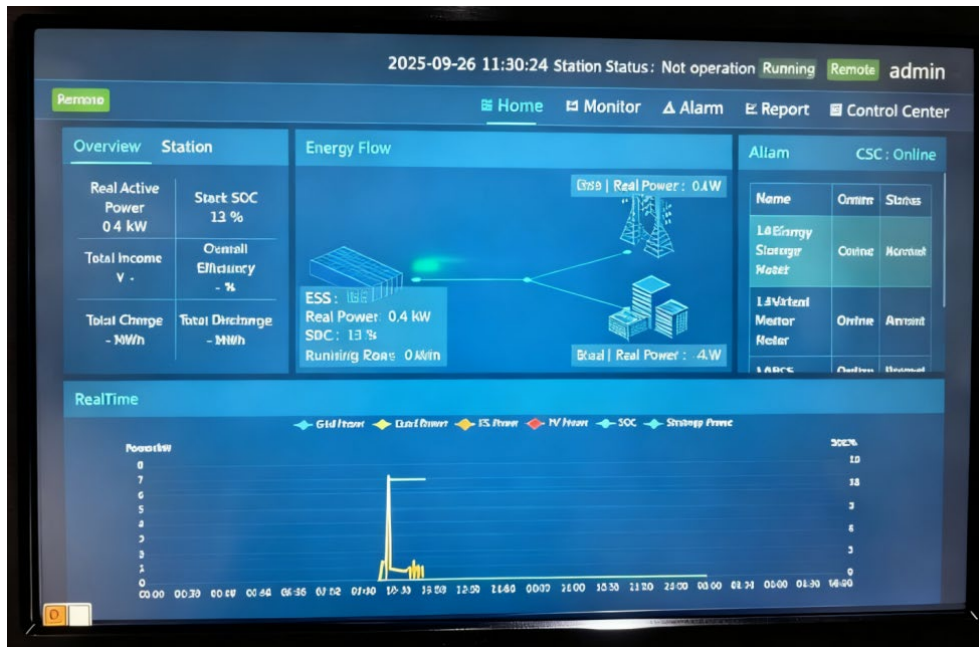

Module	Explain
Overview data	<ol style="list-style-type: none"> <li>1. Charge/discharge on the same day: take the primary data of the electricity meter (customized curve can be checked, not correctable)</li> <li>2. Total charge/discharge: summarized from the power report</li> <li>3. Yesterday/Total revenue: Summary from the income statement</li> <li>4. System efficiency: system efficiency = total discharge quantity/total charge quantity</li> </ol>

	<ol style="list-style-type: none"> <li>5. Plant age: Plant age = Current date-commissioning date</li> <li>6. Statistics time: Get once when entering the page, then refresh every 10 seconds</li> </ol>
Energy flow	<ol style="list-style-type: none"> <li>1. Energy storage charge/discharge state: charge/discharged/still. <ol style="list-style-type: none"> <li>a) When all PCS and all branch states are idle, display idle</li> <li>b) When any one of the paths is charged or discharged, combined with the total power, if the total power is positive, it is charging; if the total power is negative, it is discharging.</li> </ol> </li> <li>2. Real-time energy storage power: The total power of all energy storage nodes and reference equipment. In case of partial table or equipment interruption, it will display "-"</li> <li>3. SOC: Take the arithmetic mean of all battery stack SOC</li> <li>4. Available power: Take the total amount of power that all the battery stacks can put out</li> <li>5. Real-time power of the grid: Take the power of the common connection point-power reference equipment</li> <li>6. Real-time load power: Take the total value of all load nodes and power reference equipment</li> </ol>
Alarm status	<ol style="list-style-type: none"> <li>1. Cloud station communication: normal/abnormal (the cloud cannot communicate with the station EMS normally, which is usually a network problem and does not affect the normal operation of the station EMS)</li> <li>2. Alarm: normal/fault/alarm</li> <li>3. Communication: normal/delay (no device data obtained after 3 minutes)/ offline (no device data obtained after 15 minutes)</li> </ol>
Real-time operation	<p>Here, the curve of each value from 0 o'clock to 6 o'clock the next day is drawn, with the minimum granularity of 1 minute</p> <ol style="list-style-type: none"> <li>1. The power of the grid, the load power, the energy storage power, the SOC calculation logic and the logic of energy flow are consistent</li> <li>2. Strategy power: Draw a curve from the current time to 06:00 the next day according to the power set in the preset strategy template</li> <li>3. Demand limit: Take the current time point, the demand protection value of the common connection point</li> <li>4. Click the Settings button in the upper right corner of the module to configure the curves to be displayed here.</li> </ol>

#### 4) Equipment monitoring

real-time operation

Display the macro data of the station and the curve of the station level parameters, including the active and reactive power of the station level, the SOC curve of the battery stack, and the charge and discharge of today.

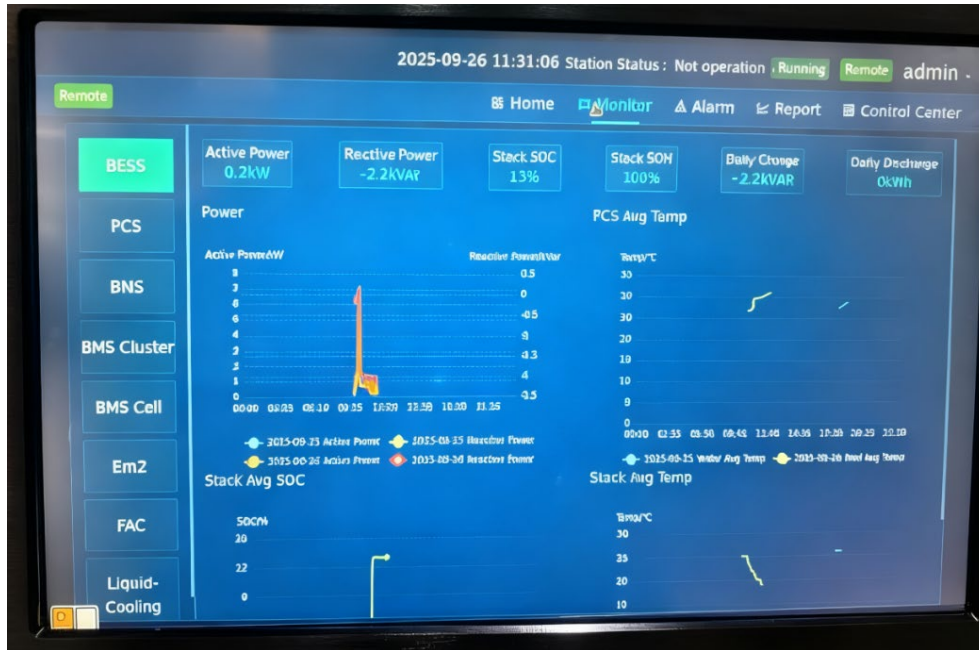

#### 5) PCS

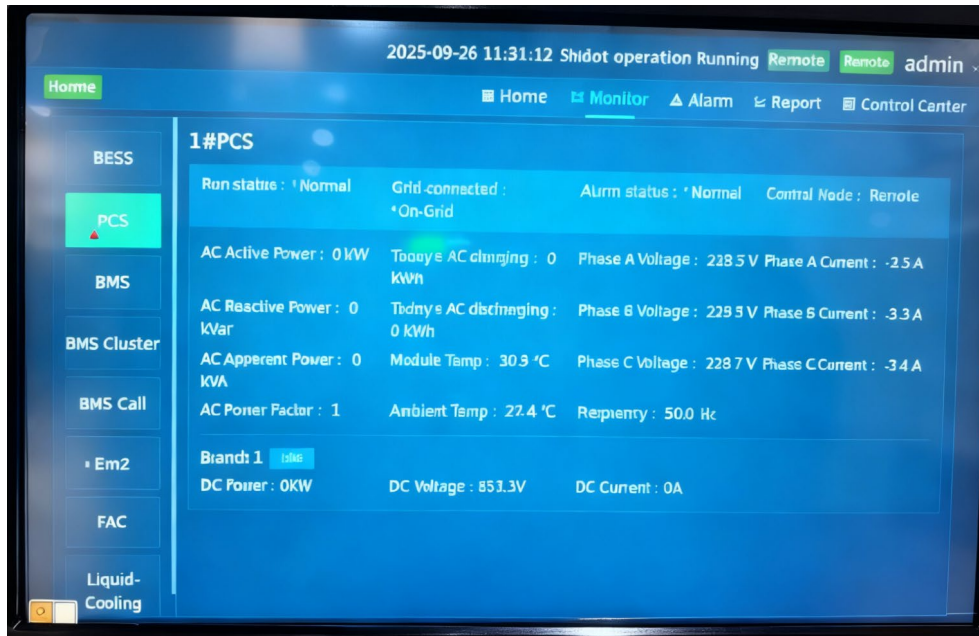

Module	Explain
Data specification	<ol style="list-style-type: none"> <li>1. Running status: (This parameter is a general device parameter, and will not be repeated later)               <ol style="list-style-type: none"> <li>a. move</li> </ol> </li> </ol>

	<ul style="list-style-type: none"> <li>b. cease</li> <li>2. Grid-connected status: <ul style="list-style-type: none"> <li>a. Grid-connected mode: when PCS is connected to the city power grid</li> <li>b. Off-grid mode: When PCS is disconnected from the urban power grid, it usually operates in off-grid mode under the micro-grid scenario</li> </ul> </li> <li>3. Alarm status:(This parameter is a general device parameter, which will not be repeated later) <ul style="list-style-type: none"> <li>a. normal</li> <li>b. report an emergency</li> <li>c. Fault (when alarm and fault exist at the same time, the fault is displayed first)</li> </ul> </li> <li>4. control model : <ul style="list-style-type: none"> <li>a. Remote mode: Log in to the energy storage manager on the web terminal and enter the remote control EMS of a single station</li> <li>b. Local mode: When EMS is controlled locally through the screen connected to the EMS industrial computer, you can switch between [remote/local mode] in the system management. After switching to local mode, the system will reject remote control commands, and the remote login to energy storage manager cannot control EMS</li> </ul> </li> <li>5. All other data are collected directly from the device, if not collected then displayed "-"</li> </ul>
PCS by-pass	<ul style="list-style-type: none"> <li>1. If the PCS has no branch, one branch is displayed by default;</li> <li>2. If there are multiple branches, display multiple branches</li> </ul>

6) **BMS pandect**

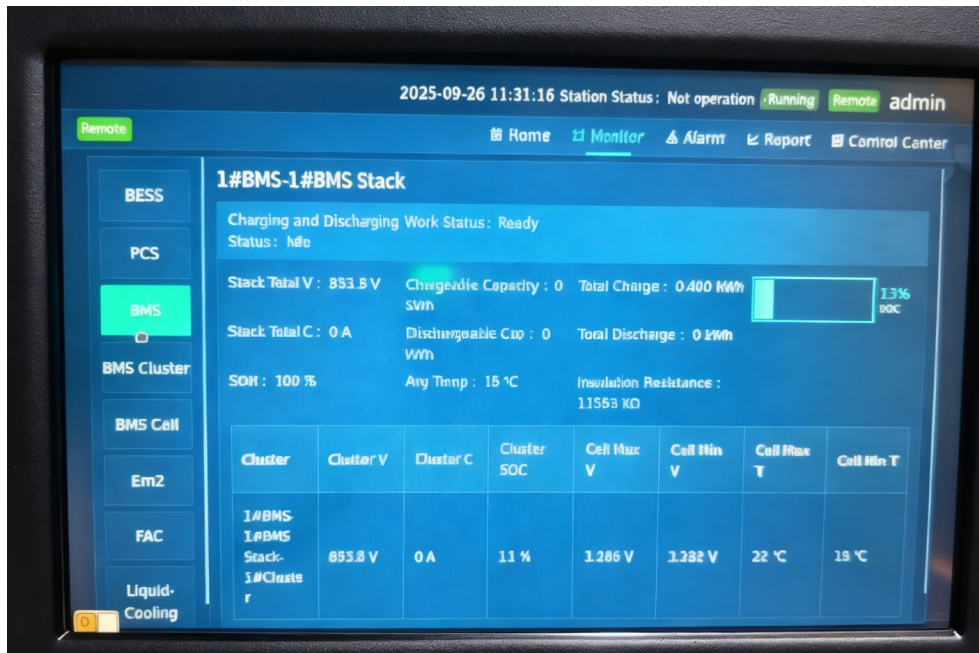

Module	Explain
data specification	<ol style="list-style-type: none"> <li>1. operative mode :               <ol style="list-style-type: none"> <li>a. charge</li> <li>b. discharge</li> <li>c. stewing</li> </ol> </li> <li>2. All other data are collected directly from the device, if not collected then displayed "-"</li> </ol>

7) BMS battery cluster

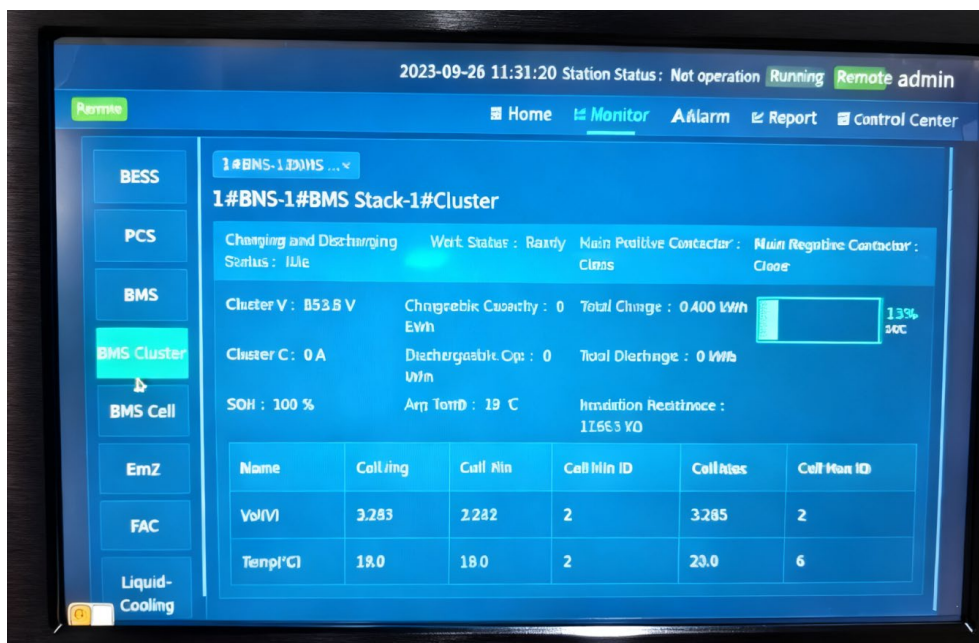

Module	Explain
data specification	<ol style="list-style-type: none"> <li>1. operative mode :               <ol style="list-style-type: none"> <li>a. charge</li> <li>b. discharge</li> <li>c. stewing</li> </ol> </li> <li>2. Main contactor:               <ol style="list-style-type: none"> <li>a. Closed (in general, the contactor states of multiple clusters are closed and open at the same time)</li> <li>b. break</li> </ol> </li> <li>3. Main negative contactor:               <ol style="list-style-type: none"> <li>a. close</li> <li>b. break</li> </ol> </li> <li>4. All other data are collected directly from the device, if not collected then displayed "-"</li> </ol>
Switching devices	<ol style="list-style-type: none"> <li>1. Click the drop-down list to switch between battery stacks and view the battery cluster data under different reactors</li> </ol>

8) cell



Module	Explain
Switching devices	<ol style="list-style-type: none"> <li>1. Click the drop-down list in the upper left corner to switch battery clusters and view the data of individual cells under different battery clusters;</li> <li>2. The first battery stack and the first battery cluster are selected by default</li> </ol>

View switching	1. Click the button in the upper right corner to switch the data to a distribution chart, table, or bar chart. The bar chart supports X-axis and Y-axis zooming
Parameter switching	1. Click the button in the upper left corner to switch to view the voltage, temperature, SOC (if not collected, this parameter will not be displayed) and SOH (if not collected, this parameter will not be displayed) of each single cell under the battery cluster.
data specification	<p>1. Display the real-time voltage, temperature, SOC and SOH parameters corresponding to each cell</p> <p>2. The number of cells in each battery cluster is configured by the site delivery personnel in the [configuration file]</p> <p>3. If the number of cells is less than the number of cell parameter collection points (there are 200 cells, but only 50 cells need to be collected due to cost reasons), the temperature of the remaining cells can be supplemented (each group of parameters is 1 set, and each group of parameters takes one of the four cells)</p>

9) any meter for measuring electricity

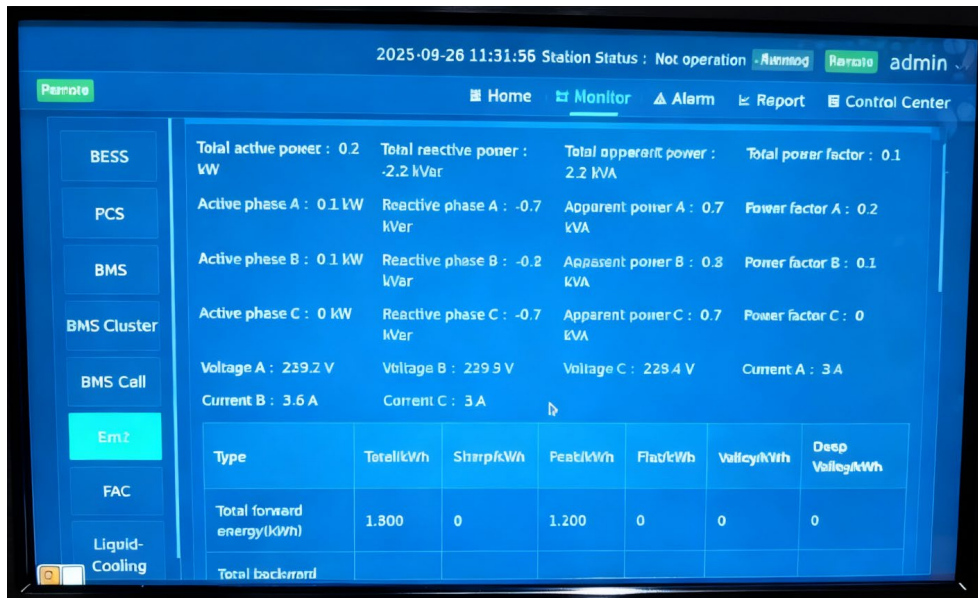

All data is collected directly from the device, if not collected then displayed "-"

10) Liquid cooling unit

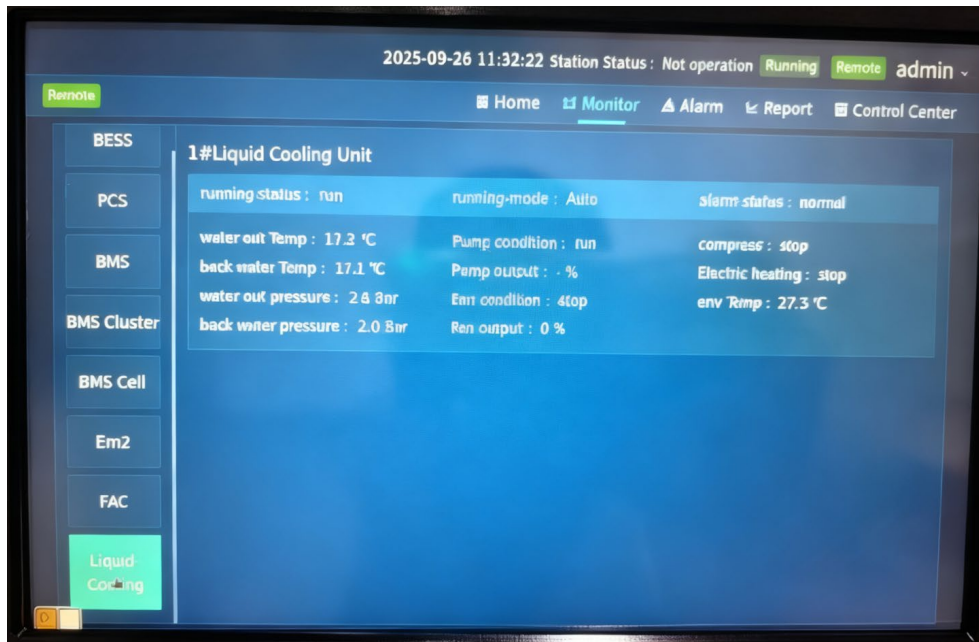

All other data are collected directly from the device. If not collected, it is displayed "-"

11) fire safety

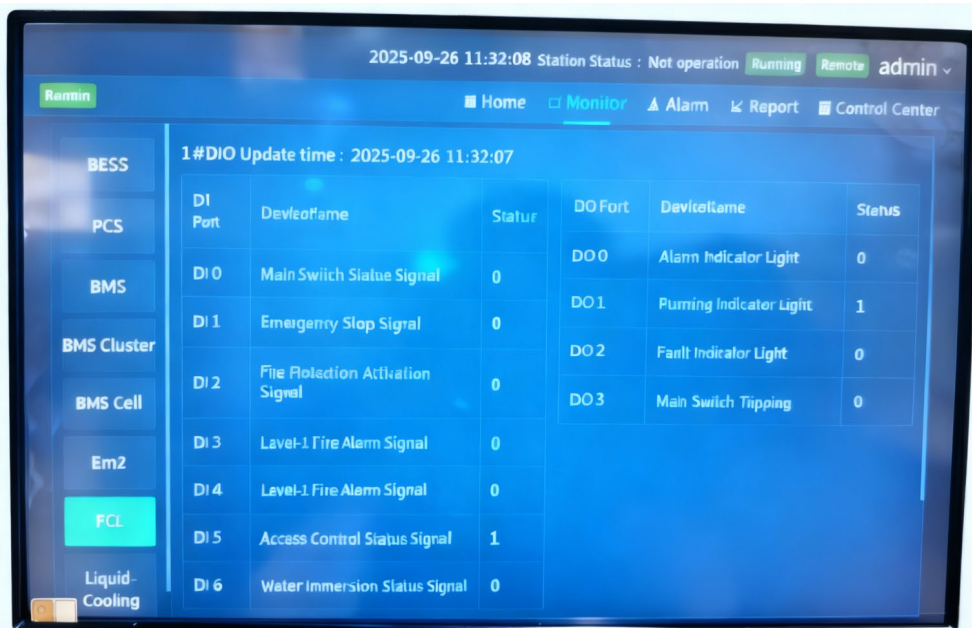

The fire safety page contains the equipment: IO controller, various sensors, measurement and control devices

All data is collected directly from the device, if not collected then displayed "-"

12) fault warning

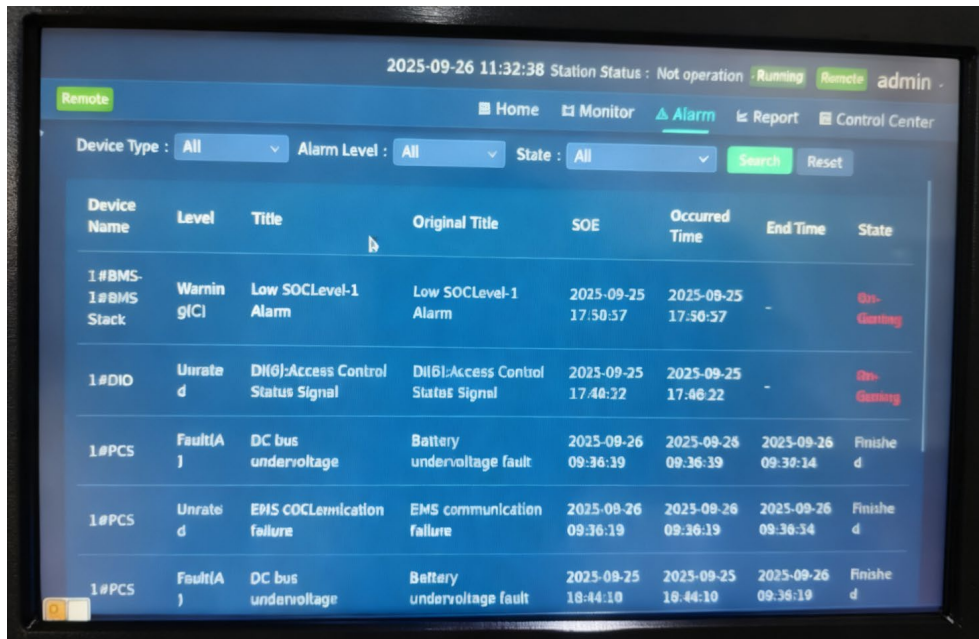

1. Today alert: shows alerts that are currently occurring or that have ended today.
2. Historical alerts: Displays alerts that have ended and whose end time is before today. Historical alerts can be queried by time.

### 13) Curve statements

Overview statistics-

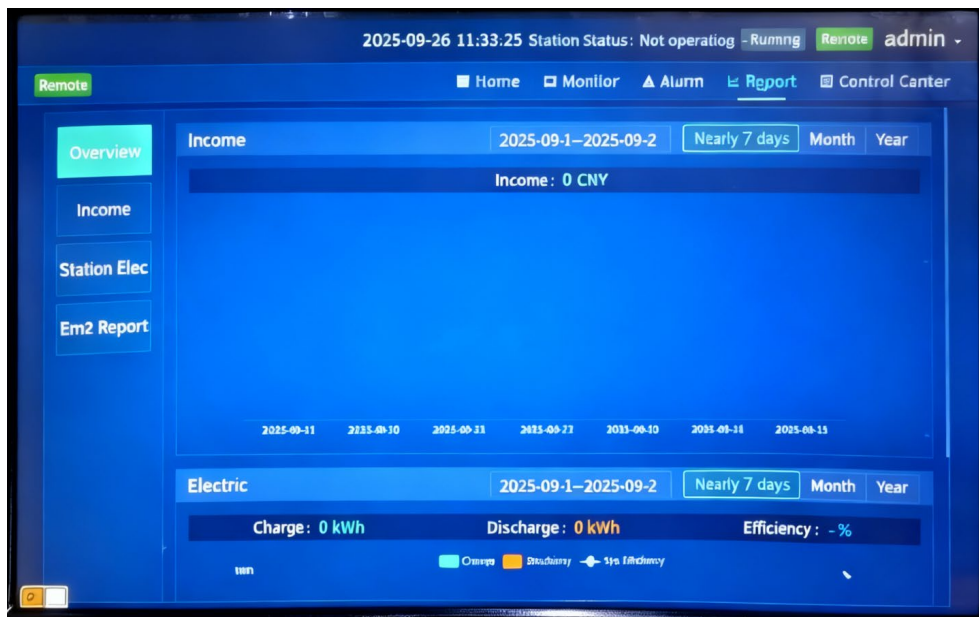

Functional module	Explain
Energy storage yield index	<ol style="list-style-type: none"> <li>1. The default query is for the last 7 days. You can click to quickly switch to the current month or year data, or you can manually select the date range selection box.</li> </ol> <ul style="list-style-type: none"> <li>• The daily return in the bar chart takes values from the income statement</li> </ul>

	<ul style="list-style-type: none"> <li>The total revenue at the top is the sum of the daily revenues for the selected dates</li> </ul>
Energy storage power indicators	<ul style="list-style-type: none"> <li>The default query is for the last 7 days. You can click to quickly switch the data of the current month or year, or you can manually select the date range selection box.</li> <li>The daily electricity value in the bar chart is taken from the electricity report</li> <li>System efficiency (%) = charge / charge</li> </ul>

14) **earning report**

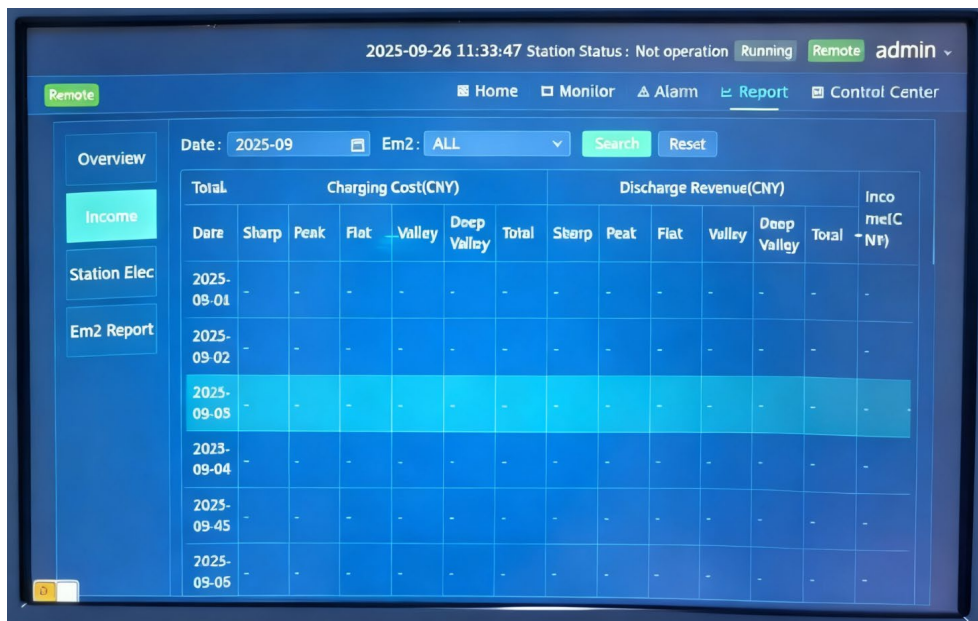

- You can choose all meters or individual meters
- Update the previous day's data at 00:30 daily in the time zone corresponding to the site
- computational formula :
- Charging cost (peak, peak, flat, valley, deep valley) = period electricity x period price
- Discharge benefit (peak, peak, flat, valley, deep valley) = period electricity x period price
- Actual revenue = discharge revenue (daily summary) -charging cost (daily summary)
- If the site has enabled [Day-ahead Price], the page will look like this:
- Charging cost or discharging benefit = electricity per 15 minutes x electricity price per 15 minutes
- Actual revenue = discharge revenue-charge cost

15) **Electricity statements**

2025-09-26 11:33:58 Station Status : Not operation Running Remote admin

Remote Home Monitor Alarm Report Control Center

Overview Date : 2025-09 Search Reset

Date	Charge/kWh						Discharge/kWh						Effr/%
	Shap	Peak	Flat	Valley	Deep Valley	Total	Sharp	Peak	Flat	Valley	Deep Valley	Total	
2025-09-01	-	-	-	-	-	-	-	-	-	-	-	-	-
2025-09-02	-	-	-	-	-	-	-	-	-	-	-	-	-
2025-09-03	-	-	-	-	-	-	-	-	-	-	-	-	-
2025-09-04	-	-	-	-	-	-	-	-	-	-	-	-	-
2025-09-05	-	-	-	-	-	-	-	-	-	-	-	-	-
2025-09-06	-	-	-	-	-	-	-	-	-	-	-	-	-

- Update the previous day's data at 00:30 daily in the time zone corresponding to the site
- computational formula :
- T-day charging quantity (peak, peak, flat, valley, deep valley) = energy storage meter's forward stop value at 0:00 on T+1 day-energy storage meter's forward stop value at 0:00 on T-day
- T-day discharge (peak, peak, flat, valley, deep valley) = energy storage meter's forward stop value at 0:00 on T+1 day-energy storage meter's forward stop value at 0:00 on T-day
- Comprehensive efficiency = charge quantity / charge quantity \*100%
- If the site has enabled [Day-ahead Price], the page will look like this:
- Electricity = Energy storage meter every 15 minutes of the difference in the meter \* the price of electricity per 15 minutes

16) Meter statements

2025-09-26 14:59:48 Station Status : Not operation Running Local admin

Local Home Monitor Alarm Report Control Center

Overview Capacity Stop

Income

Station Elec

Em2 Report

Date : 2025-09-2025-09 Em2 : #Energy Stora... Search Reset

Date	Charge/kWh						Discharge/kWh						Effr/%
	Sharp	Peak	Flat	Valley	Deep Valley	Total	Sharp	Peak	Flat	Valley	Deep Valley	Total	
2025-09-03	-	-	-	-	-	-	-	-	-	-	-	-	-
2025-09-03	-	-	-	-	-	-	-	-	-	-	-	-	-
2025-09-03	-	-	-	-	-	-	-	-	-	-	-	-	-
2025-09-04	-	-	-	-	-	-	-	-	-	-	-	-	-
2025-09-04	-	-	-	-	-	-	-	-	-	-	-	-	-

Functional module	Explain
Electricity meter reading	<ol style="list-style-type: none"> <li>1 The default query is for the last 7 days (excluding today), and you can manually select the date range by clicking the date range selection box. You can choose to view each meter.</li> <li>2. Update the previous day's data at 00:30 daily in the time zone corresponding to the site</li> <li>3. Time-of-use electricity source: If the [Meter Time-of-Use] option is selected, it indicates that each time-of-use measurement is directly read from the meter. If the [EMS Time-of-Use] option is chosen, the system first configures the EMS device, then calculates the total electricity consumption by dividing it into configured time periods. Modifications can be made according to the "System Management-EMS Period Management" section.</li> <li>4. The calculation formula is consistent with the electricity report.</li> </ol>
Meter reading	<ol style="list-style-type: none"> <li>1. The default query is for the last 15 days (excluding today), and you can manually select the date range by clicking the date range selection box. You can choose to view each meter.</li> <li>2. The meter stop value at 00:00 of the date marked in the display, and the integrated multiplier set by the meter. The stop value here is the actual kilowatt-hour multiplied by the integrated multiplier.</li> </ol>

## 17) Control center

When entering the [Control Center] module, for security reasons, you need to enter the password and click "OK". If the password is correct, you can enter. Factory default password: 888888

If the password is wrong, please consult your platform administrator or our business personnel.

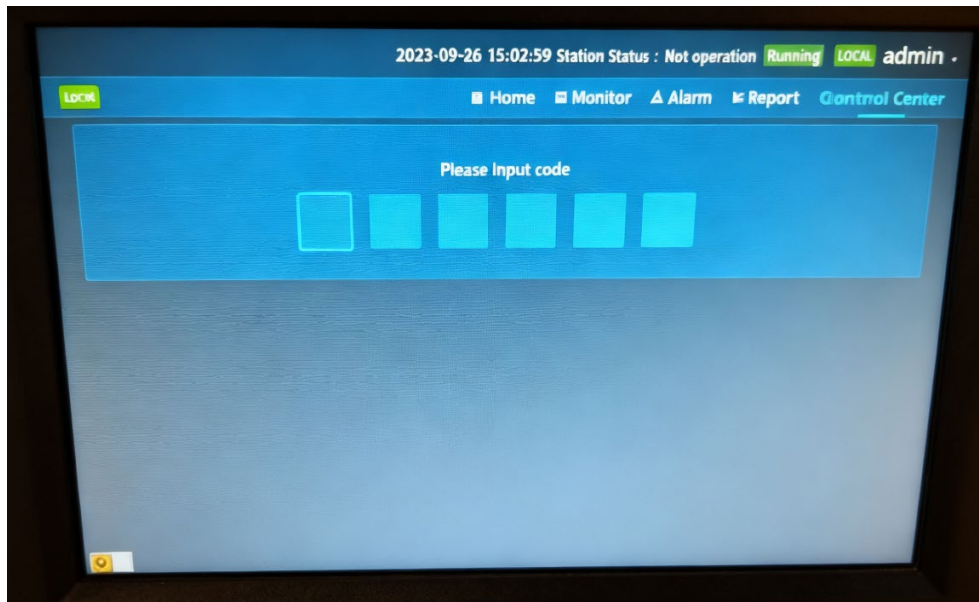

### 18) tactical management

Strategy start/stop and switch

Click [Startup Strategy]. When the status of the strategy changes to [Strategy running], it means that the strategy is enabled successfully

After the strategy is running, click [Stop Strategy] to stop sending the strategy



### Manual strategies

In manual mode, the operation and maintenance personnel manually control the start/stop of the energy storage system, charge/discharge mode switching and other operations. The interface also displays the real-time core data for monitoring.

Click the [Configuration] button to configure all PCS



Enter the manual policy configuration dialog box to set up startup

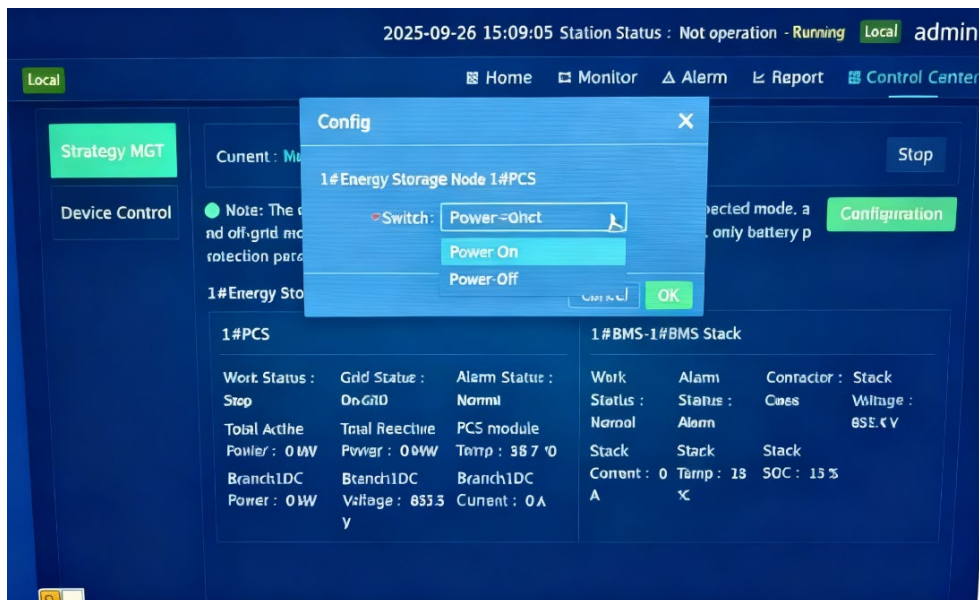

19) DC

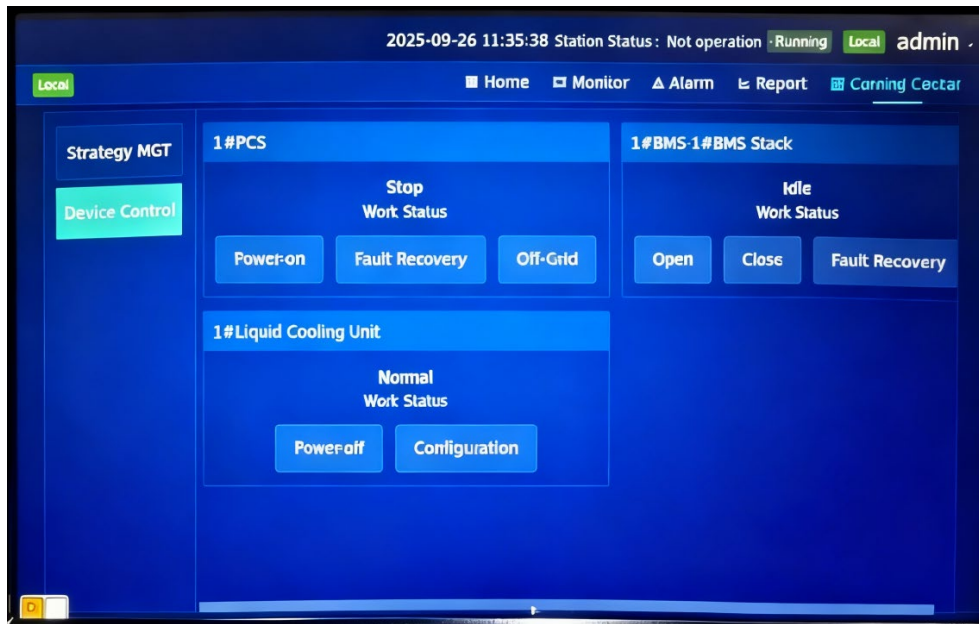

Device type	Control item
PCS	<p>Power on/off: Send power on/off commands to the device</p> <p>Note: When a preset policy is running, it may conflict with the instructions of the preset policy. Therefore, you must stop the policy before using it</p> <p>Off-grid and grid-connected: Send off-grid and grid-connected commands to the device</p> <p>Fault recovery</p>
BMS	<p>Contactor closing and opening: Send the main negative contactor closing and opening instructions to BMS</p> <p>Note: When a preset policy is running, it may conflict with the instructions of the preset policy. Therefore, you must stop the policy before using it.</p> <p>There is a certain sequence between BMS and the opening of PCS switch, which depends on the wiring situation on site. Examples are as follows</p> <p>In the power down scenario, the PCS is shut down first and then the opening action is performed</p> <p>In the upper power scene, the closing action of BMS is executed first, and then the startup action of PCS is executed</p> <p>Fault recovery</p>
Liquid cooling unit	<p>Power on/off: Send power on/off commands to the device</p> <p>Configuration (the following is the standard control point. If other parameters of remote control devices are required, you can use the [device read and write] function)</p>

---

Cooling: Send cooling mode and target temperature to the device (EMS will continue to send instructions until manually modified)

Heating: Send heating mode and target temperature to the device (EMS will continue to send instructions until manual modification)

Automatic mode: Send automatic mode and target temperature to the device (EMS will continue to send instructions until manually modified)

Self-loop: Send the device to self-loop mode (EMS will continue to send instructions until manually modified)

EMS control model :

EMS will continue to judge the condition and send the corresponding instruction to the liquid cooling unit

Action 1: EMS determines the maximum temperature of the battery cell under the BMS corresponding to the liquid cooling unit, and automatically determines and switches the refrigeration and heating modes of the liquid cooling unit (the user needs to input the refrigeration on/off points and heating on/off points)

Action 2: When the liquid cooling unit is in non-cooling and cooling mode, the mode command is sent to the liquid cooling unit (the user needs to select the mode)

Self-circulating mode

await the opportune moment

shut down

No control: Send no control command to the device. The device maintains the last issued configuration by default, and EMS will not continue to send commands after that.

---

## 20) system management

Enter system management from the drop-down menu in the upper right corner.



21) Power station information management

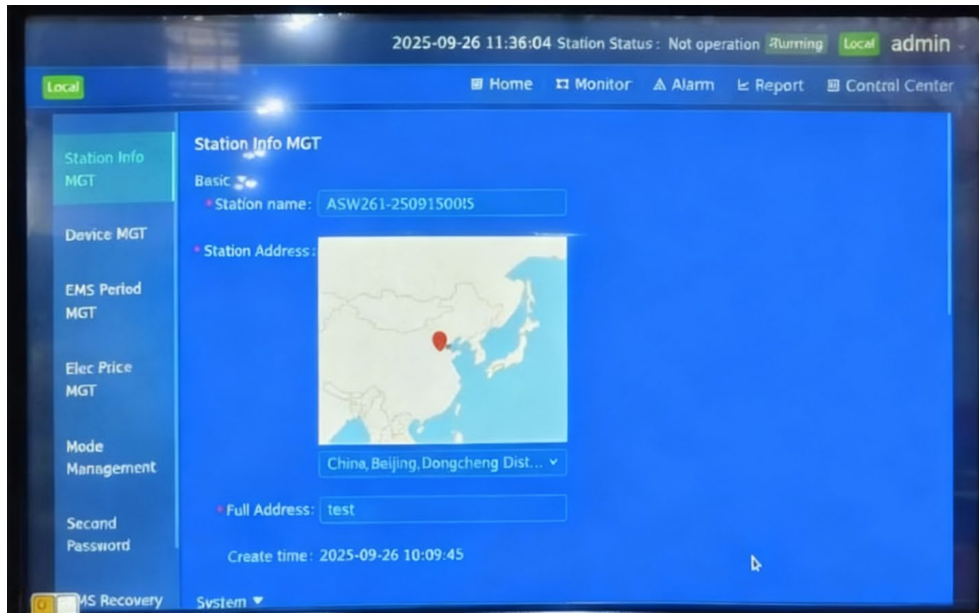

22) device management

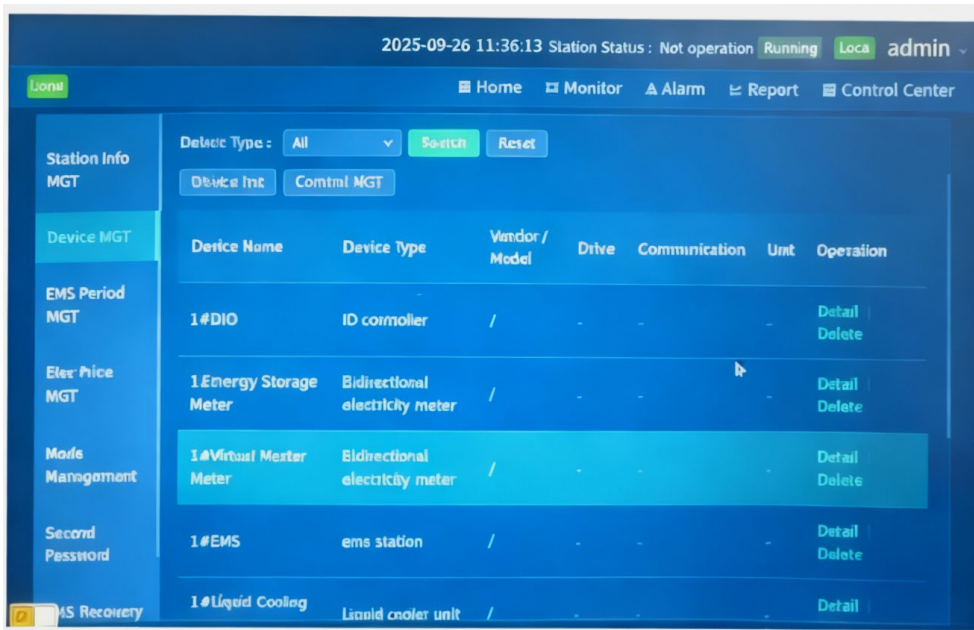

**23) EMS period management**

View EMS time period Settings. When the time period source is set to "EMS time period", the site runs on a time period configured here.

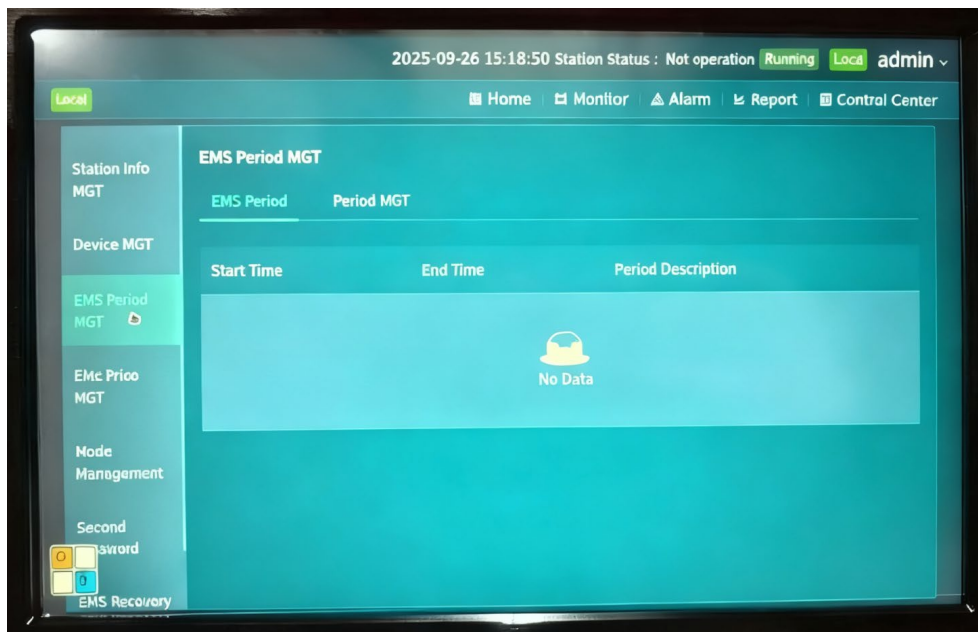

**24) Electricity pricing management**

Check out this month's peak and valley rates.

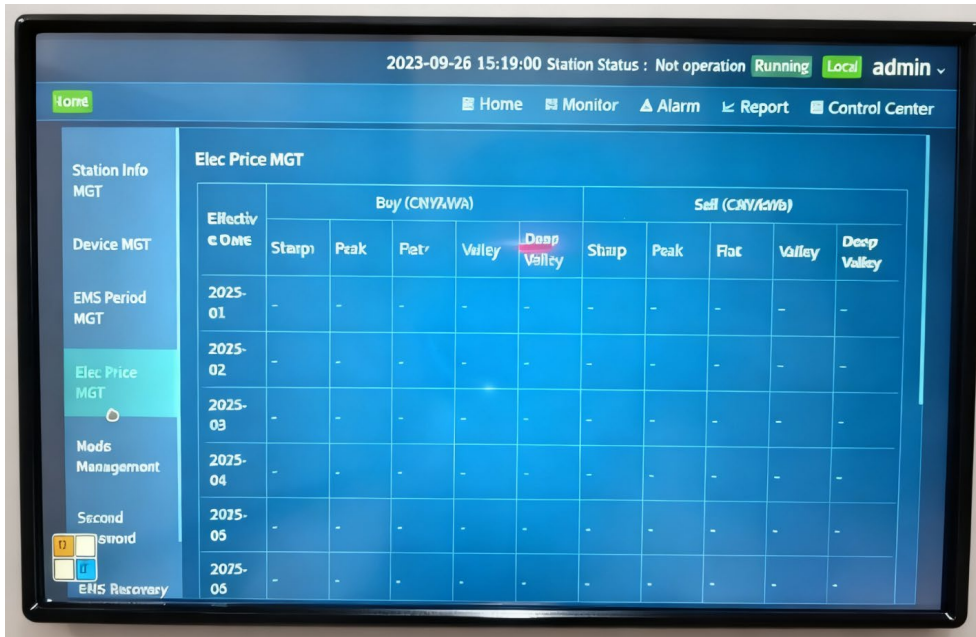

25) **MODELLING MANAGEMENT**

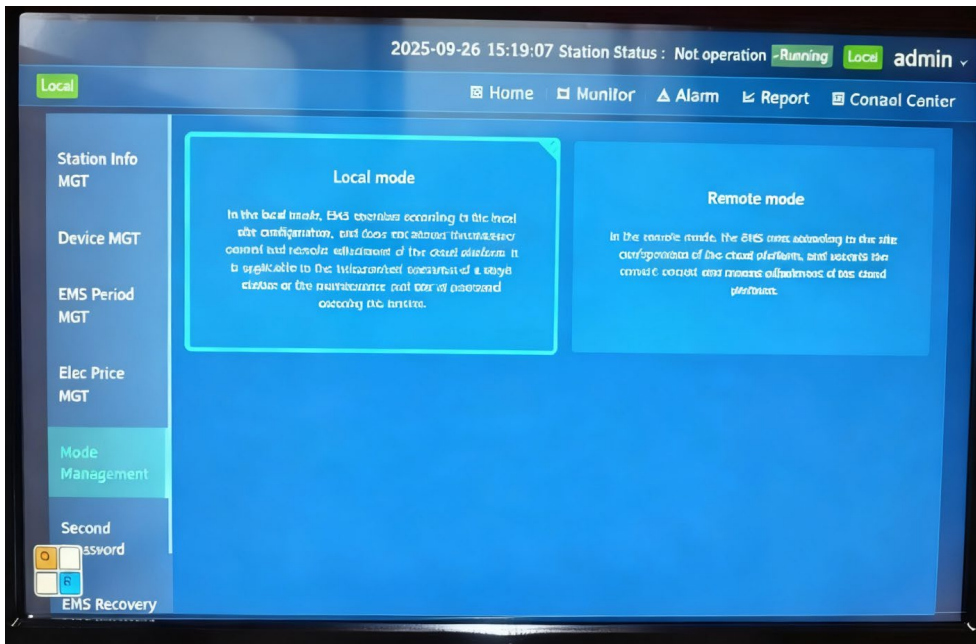

Switch between local and remote modes of the site.

26) **Secondary password**

The digital password required to enter the control center or issue device control can be modified here.

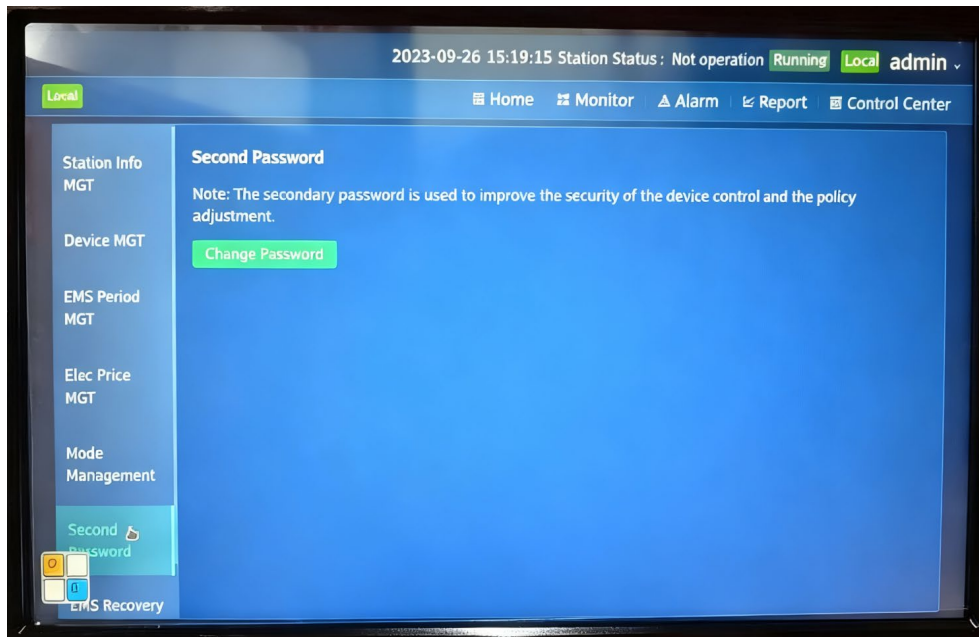

## 27) EMS reset

In case of major failure, the EMS can be reset on this interface to reissue the policy.

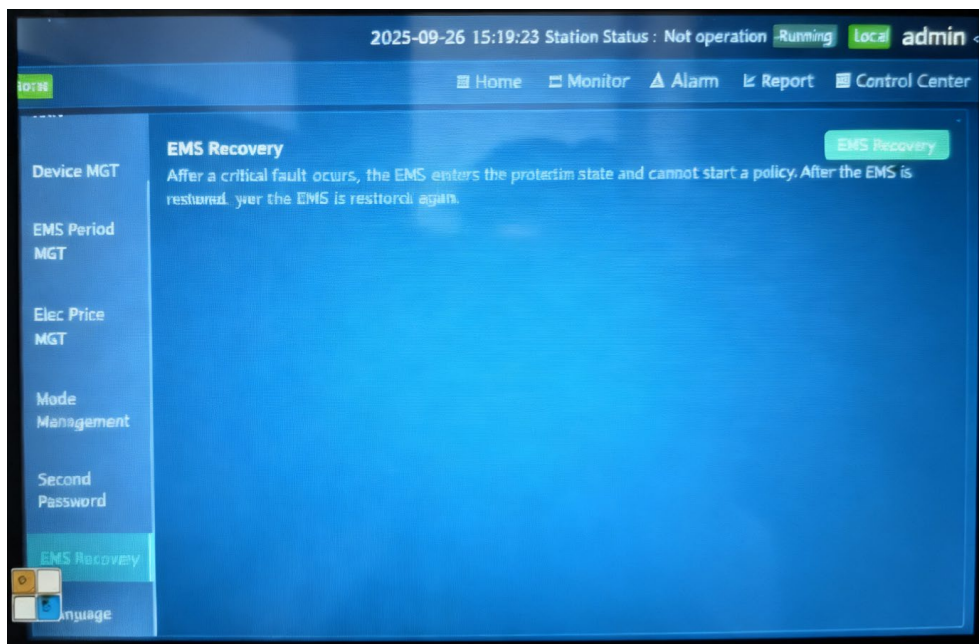

## 28) language

Switch between English and Chinese.

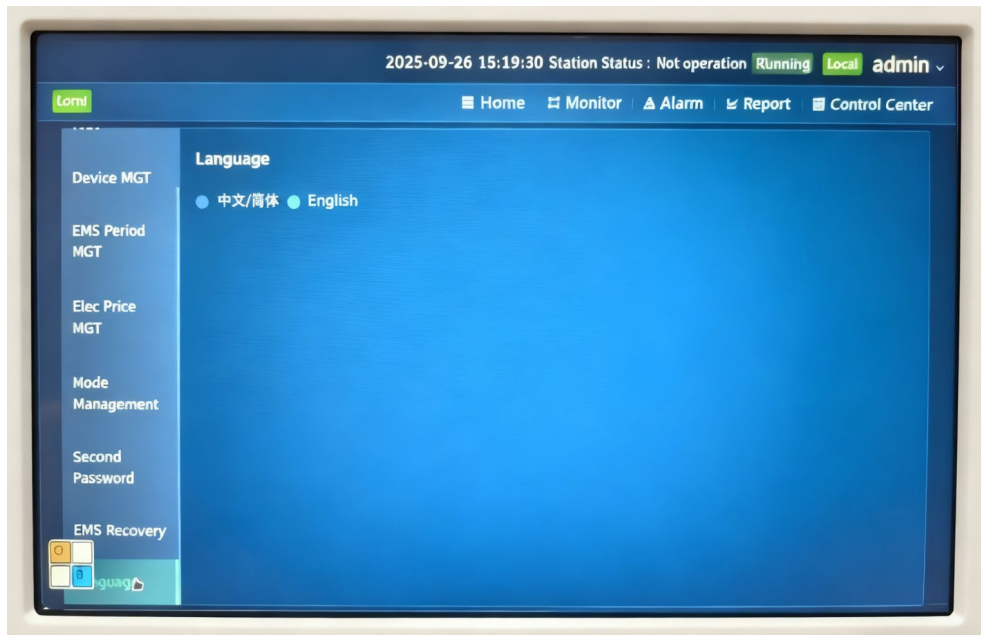

## 7 Fault treatment

The energy storage cabinet has perfect protection function and warning information. Once a fault occurs, the relevant fault information can be read through EMS.

Before seeking service, users can press the prompts in the table for self-test, analyze the cause of the fault and find a solution. Do not disassemble machine parts during self-test. If the problem cannot be solved, please contact the agent or directly contact us.

### Level of failure

- **Fault:** indicates that the energy storage cabinet, power grid, battery and other external conditions are abnormal, and the automatic shutdown is required.
- **Warning:** indicates that the smart energy storage terminal, power grid, battery and other external conditions are abnormal. The system does not stop, and personnel need to eliminate the abnormal conditions in time. All first-level alarms, first-level thresholds, second-level thresholds and second-level alarms belong to warning.

### Fault reset

The fault reset mode is divided into automatic reset and manual reset.

- **Automatic reset fault:** After the fault occurs, the system will clear the fault by itself at regular intervals.
  - If the fault condition is eliminated, the system exits the fault state;
  - If the fault condition still exists, the fault is reported again.

The number of automatic reset times of the fault can be set by the function code. When the number of automatic reset times is used up, the fault will not be automatically reset until the user manually resets the system, and the number of automatic reset times of the fault can be counted again.

- **Manual reset fault:** after the cause of the fault is eliminated, the energy storage integrated cabinet can be restored to work by clicking reset.

(Note: The fault name and code are detailed in the light EMS standard alarm summary file)

If a third-party cloud platform is connected to the local EMS, please communicate with us in detail about the connection mode (communication protocol or point meter)

No.	Fault name	Possible causes	Resolvent
1	Overvoltage on the power grid	The grid voltage is higher than the AC overvoltage point.	Check whether the power grid voltage is normal.
2	Power grid AC under-voltage	The grid voltage is lower than the AC under-voltage point.	Check whether the power grid voltage is normal.
3	Off-grid AC overvoltage	The off-grid AC voltage is higher than the AC overvoltage point.	Please contact the manufacturer for details.
4	Off-grid AC under-voltage	The off-grid AC voltage is lower than the AC under-voltage point.	Please contact the manufacturer for details.

5	and grid-connected AC over frequency	The grid frequency is higher than the over-frequency point.	Check the power grid frequency.
6	Grid-connected communication frequency deficiency	The grid frequency is below the under-frequency point.	Check the power grid frequency.
7	AC overcurrent fault	Short circuit on AC side / AC load is too large	Please contact the manufacturer for details.
8	Output phase loss fault	The main circuit output line is loose/short circuit between the main circuit output and ground.	Check whether the three-phase output wiring is normal and whether the three-phase voltage is normal.
9	Voltage imbalance in the grid	The voltage amplitude difference of three-phase power grid exceeds the allowable range/power grid input is missing	Check whether the power grid voltage is normal
10	Environmental overheating	The ambient temperature exceeds the protection point/fan failure	Check whether the fan is running normally/Check whether the temperature sensor is working properly
11	Low environmental temperature	The ambient temperature is lower than the protection point	Check whether the temperature sensor is working properly.
12	IGBT overheating	Environmental temperature is too high/current is too large	Check whether the current is within the normal range/check whether the temperature sensor works normally/check whether the fan runs normally and whether the ventilation is blocked.
13	IGBT low temperature	The ambient temperature is too low	Check whether the temperature sensor is working properly
14	The AD has too much zero drift	Zero drift is excessive.	Please contact the manufacturer for details.
15	Low insulation resistance	The insulation resistance is low.	Check whether the main circuit is connected to the ground/please contact the manufacturer for details
18	IGBT failure in phase A	A phase A IGBTDESET protection.	Please contact the manufacturer for details.
19	B phase IGBT fault	B phase IGBTDESET protection.	Please contact the manufacturer for details.
20	IGBT failure in phase C	C phase IGBTDESET protection.	Please contact the manufacturer for details.

21	Grid voltage reversal	The grid is out of order.	Exchange any two phases in a three-phase line.
22	EMS communication failure	EMS communication is disconnected.	Check whether the EMS communication line is connected properly.
23	Battery voltage is too high	The battery voltage is higher than the battery overvoltage point during operation.	Check the battery voltage.
24	The battery voltage is too low	The battery voltage is lower than the battery under-voltage point during operation.	Check the battery voltage.
25	Host abnormal shutdown	The console detects that the host has stopped running.	Please contact the manufacturer for details.
26	Energy storage converter communication	Communication between energy storage converter and EMS is abnormal	Check whether the communication line between EMS and energy storage converter is connected
27	BMS communication	Communication between BMS and EMS is abnormal	Check whether the communication line between EMS and BMS is connected
28	Liquid cooling unit communication	Communication between liquid cooling unit and EMS is abnormal	Check whether the communication line between EMS and liquid cooling unit is connected well, and whether the liquid cooling unit is in the on state.
29	Temperature and humidity sensor communication	Communication between temperature and humidity sensor and EMS is abnormal	Check whether the communication line between EMS and temperature and humidity sensor is connected
30	Fire system communications	Communication between the fire system and EMS is abnormal	Check that the communication line between the EMS and the fire system is properly connected
31	Meter communication	Communication between meter and EMS is abnormal	Check whether the communication line between EMS and meter is connected
32	Measuring meter communication	Measure abnormal communication between the meter and EMS	Check whether the communication line between EMS and measuring meter is connected
33	System emergency stop	The emergency stop switch is activated	Check whether the emergency stop switch has been opened

34	BMS_ Single unit overvoltage level 1	The battery has PCS and is not down.	Level 1 overvoltage limits charging, level 2 and level 3 overvoltage stops charging. Discharge or stand by until the overvoltage alarm disappears and the charging limit is restored
	BMS_ Single unit overvoltage Level 2		
	BMS_ Single unit overpressure level 3		
35	BMS_Single unit under voltage level 1	The battery is empty and the PCS is not stopped.	Under-voltage discharge is limited at level 1, and under-voltage discharge stops at level 2 and 3. Open the under-voltage at level 2 and 3 to automatically enter forced charging until the protection disappears
	BMS_ Single cell under voltage Level 2		
	BMS_ Single cell under voltage level 3		
36	BMS_ single body overtemperature level 1	hyperpyrexia .	Level 1 overtemperature limits charging and discharging, level 2 and level 3 overtemperature stops charging and discharging. Check whether the air conditioning refrigeration is running normally, whether the air conditioning refrigeration and heating parameters are set properly, and whether the ventilation is blocked. After the overtemperature alarm is removed, resume
	BMS_ single overtemperature level 2		
	BMS_ Single overtemperature level 3		
37	BMS_ Monomer low temperature stage 1	The temperature is too low.	Level 1 undertemperature limits charging and discharging, level 2 and 3 undertemperature stops charging and discharging. Check whether the air conditioning heating is normal, whether the air conditioning refrigeration and heating parameters are set properly, and restore after the undertemperature alarm is removed
	BMS_ monomer low temperature stage 2		
	BMS_ monomer low temperature level 3		
38	BMS_ Charging overcurrent alarm	The charging current exceeds the maximum current of the system.	Automatically reduce power and delay recovery to check whether the operating current is greater than the rated current
39	BMS_ discharge overcurrent alarm	The discharge current exceeds the maximum current of the system.	Automatically reduce power and delay recovery to check whether the

			operating current is greater than the rated current
40	Low coolant level alarm	Lack of coolant	Please contact the manufacturer for details.

## 8 Daily care and maintenance

Due to the influence of temperature, humidity, dust and vibration in the environment, the internal components of the energy storage cabinet will age, which may cause the failure of the energy storage cabinet or reduce the service life of the energy storage cabinet. Therefore, it is necessary to carry out daily and regular maintenance and maintenance work on the energy storage cabinet.

### CAUTION

- Safety precautions must be taken before maintenance of the energy storage cabinet.
- Before maintenance, the correct operating procedures must be strictly followed.
- Before maintenance, make sure that the power is disconnected.
- There is an energy storage capacitor inside the energy storage cabinet. After power off, it must be waiting for more than 35 minutes to confirm that there is no power in the energy storage cabinet before maintenance can be carried out.
- After the power is disconnected, a warning sign should be hung at the disconnect point to prevent people from re-energizing during maintenance.
- To avoid accidental danger, maintenance personnel should wear insulation protective equipment during maintenance.
- Energy storage integrated cabinets can only be maintained by personnel with professional qualifications.

### 8.1 Daily inspection items

Daily inspection items are carried out according to the following points.

No.	Check item
1	Real-time monitoring of the input, output voltage and current and operating status of the energy storage cabinet is required Regular observation is required to find abnormal operation of energy storage cabinet or abnormal voltage and current, which should be maintained in time protect .
2	No abnormal sound is heard in the energy storage cabinet.
3	No odor was detected in the energy storage cabinet.
4	Read the internal temperature of the energy storage cabinet and observe that the temperature is within the normal range.

## 8.2 Periodic inspection projects

### **DANGER**

- Energy storage cabinets can only be maintained by personnel with professional qualifications.
- Before maintenance, the correct operating procedures must be strictly followed.
- Before maintenance, make sure that the power is disconnected.

Regular inspection mainly focuses on the daily inspection and difficult to check in the daily operation.

No.	Inspection item	Scope of examination
1	Voltage detection	Check the voltage of the battery system through the monitoring system. Check whether the system voltage is abnormal, such as a single cell battery voltage that is abnormally high or low.
2	SOC check	Check the SOC of the battery system through the monitoring system. Check whether the SOC of the battery string is abnormal.
3	cable check	Examine all cables in the battery system visually. Check for breaks, aging, or looseness.
4	Balance maintenance	If the battery string is not fully charged for a long time, it will become unbalanced. Solution: Balance maintenance (fully charged) should be performed every 3 months, usually automatically by the communication between the system and external devices.
5	Output relay check	At low load (low current), the control output relay is closed and opened to hear a click, which means that the relay can be closed and opened normally.
6	Historical review	Analyze historical records to check for accidents (alarms and protection) and analyze the causes.

## 9 Operations content

### 9.1 Battery cluster operations

(1) Operation and maintenance repair project

Order number	Maintenance projects	Technical points and precautions	Quality standard
1	Check the structure of battery appearance	<p>Key inspection: a. Visualize whether the shell is clean, if</p> <p>Wipe any stains clean and keep it ventilated and dry</p> <p>Dryness; b. visually check whether the shell is leaking or deformed</p> <p>, Should be replaced in time; c. Reference records,</p> <p>And actually measure whether the ambient temperature is normal.</p>	<p>The appearance of the battery should be no deformation, leakage, cracks and stains; the mark should be clear; the positive and negative terminals should be clearly marked for easy connection.</p>
2	Voltage, internal resistance (conductivity) measurements	<p>Voltage measurement: Use a multimeter or DC voltmeter to measure the terminal voltage of the battery and the total voltage of the battery pack, and record and judge.</p> <p>Measuring Internal Resistance (Conductivity): Use an internal resistance meter (or conductivity meter) to measure the internal resistance (conductivity) of individual cells and compare them with each other. If any cell shows abnormally high internal resistance, focus on checking the following aspects: a. Whether the battery is operating in the correct mode; b. Whether the voltage and temperature are within specified ranges; c. Whether the battery has been overcharged or undercharged for an extended period; d. Whether the operational lifespan exceeds the manufacturer's recommended duration.</p>	<p>The total voltage of the battery pack should meet the relevant setting parameters provided by the manufacturer.</p>

3	Check the battery connection;  Between battery packs, between components;	Confirm that all battery connections are fastened and no screws are present  The bolt is loose, the connection is overheated, etc. If found  If there is loosening or overheating, tighten the relevant bolts in time.	The connection is correct, no reverse or wrong connection; the screws at each conductive place are tightened; the power line and communication line skin is not damaged, and the connection is not loose;
---	---	--	---

(2) Maintenance and maintenance precautions

- For long-term storage, it is recommended to charge every 3 months;
- If there is dust and other things piled up in the ventilation, please use a vacuum cleaner to remove it;
- If the system is not used for a long time, please turn off the charging input power supply;
- Please clean the chassis with a soft dry cloth. If it is really dirty, please use a neutral non-corrosive cleaner. Do not use alcohol or ammonia compounds;
- In the process of carrying, it should be handled gently and not subjected to violent impact;
- Avoid spilling liquid onto the battery system;
- The installation and repair of battery systems shall be carried out by trained professionals;
- The charging is insufficient. If the setting value of the charging termination voltage is set too low or no temperature compensation is performed, the battery pack will be undercharged for a long time. The battery will be undercharged for a long time, which will lead to insufficient discharge of the power station and frequent alarm signals.
- Overcharging. If the charging termination voltage is set too high or temperature compensation is not carried out, the battery will be in a state of overcharge for a long time, and the battery is prone to thermal runaway, resulting in premature failure of the battery.
- The discharge voltage is too low. An important protection measure for lithium iron phosphate batteries is the discharge termination voltage, which means the battery should stop discharging when it reaches a certain voltage. If the discharge voltage is too low, it will reduce charging efficiency and make recharging difficult. Over time, this will significantly shorten the battery's lifespan.
- Long time after discharge. If the battery is not charged in time or left for a long time after discharge, it will affect the capacity, life and consistency of the battery.
- The temperature of the battery room is too high. If the temperature of the battery environment is too low, the capacity of the battery will be affected; if the temperature of the battery environment is too high, especially if the battery is in a high temperature for a long time, the life of the battery will be shortened or problems such as thermal runaway and swelling will occur.

## 9.2 Battery management system operation and maintenance

### (1) product presentation

The system control layer is based on BAU. A BAU controls several battery clusters in parallel (BCU), and each BCU obtains battery voltage, temperature and other information through BMU. BMU is responsible for collecting battery voltage, temperature information and balanced control.

The Battery Control Unit (BCU) manages all Battery Management Units (BMUs) in the battery pack. Through the CAN bus, it collects individual voltage and temperature data from each BMU. The system performs cluster-level operations including current monitoring, total voltage measurement, leakage detection, and alarm evaluation. When abnormal conditions occur, the BCU disconnects high-voltage power contactors to deactivate the battery cluster, ensuring safe operation of the battery pack.

The BAU is responsible for managing all the battery clusters (BCU). In case of serious failure of the battery cluster, the BAU actively controls the cut-off relay.

### (2) system maintenance

In order to ensure the continuous normal operation of the system, it is required to carry out regular maintenance and maintenance.

1. Product installation and storage should avoid high corrosiveness, high dust, high temperature or high humidity environment as far as possible, especially avoid metal objects falling into the current collector cabinet, energy storage high voltage box or battery box;
2. Check whether the connection line is aging, and whether the cable connection point is fastened and safe;
3. Before opening the box for maintenance, the power supply of the secondary circuit should be completely cut off, and the circuit breaker of the parallel current cabinet should be disconnected from each high-voltage box isolation concern, and the system should be left for 5 minutes or more before maintenance. Attention should be paid to not damage the system components and electrical components during disassembly and maintenance;
4. After system maintenance, trial operation should be carried out before reusing the system to ensure reliable operation after system maintenance;
5. When the product fails to work, you can refer to the manual for preliminary problem positioning and handling. If the problem still cannot be solved, please contact our engineers as soon as possible, do not disassemble parts for illegal maintenance;
6. Check whether the communication of the battery management system is normal, and whether the collecting device and balancing device can work normally;
7. Check whether the insulation of high voltage box is normal and whether the connection is normal;
8. Check whether the BMS charge and discharge protection parameters are set reasonably.

### (3) BMS battery management system test items

BMS battery management system	Maintenance location or function	Maintenance projects and treatment	Repair cycle
BMS from control (ESBMM)	Single-volt voltage	Is there any abnormal alarm of battery voltage? If yes, contact the manufacturer for treatment. Is the pressure difference significantly enlarged? If yes, observe closely	day-to-day
	Single body voltage temperature	Whether there is an abnormal alarm on the battery temperature, if yes, contact the manufacturer to deal with the obvious amplification of temperature difference, if yes, closely observe whether there is a big difference in temperature rise under similar weather conditions, if yes, closely observe	day-to-day
	Pole column temperature	Check the corresponding terminal connection for abnormal pole temperature alarm, if any	day-to-day
	communication	Check the communication wiring harness connection at the corresponding place to check for communication alarm or loss, and check whether the slave control is damaged. If damaged, replace it	day-to-day
BMS master control (ESBCM)	Pole column temperature	An extreme column temperature alarm occurs in the electrical control box. Check the power connection at the corresponding position	day-to-day
	Current abnormal	When the output current and PCS input current are significantly different, find the abnormal cluster and check its Hall and BMS master control. If damaged, replace it in time	day-to-day
	Power supply abnormal on the control box	1. Whether there is a fault, if there is an obvious indication, repair the corresponding parts according to the fault, and replace them in time if damaged; 2. If the power on and off cannot be done without fault, check the BMS master control and the fusion switch itself. If damaged, replace it in time	day-to-day
	Communication exception	Communication alarm or loss, check the communication wire bundle connection at the corresponding place, check whether the main control is damaged, if so replace it	day-to-day
BMS Display Control (ESMU)	fault warning	1. No loosening of power cable 2. No loosening of power terminal 3. No aging, damage, abnormal heating or other abnormalities of power cable	day-to-day
	Communication exception	1. No loosening of power cable; 2. No loosening of power terminal; 3. No aging, damage, abnormal heating or other abnormalities of power cable	3 months
	data consistency	Always check whether the data displayed locally is consistent with the data reported to EMS	3 months

## 9.3 Fire system operation and maintenance

### (1) product presentation

A. Use aerosol automatic fire extinguishing system for cluster level fire protection.

B. The detector is installed on the top of the battery cabinet. All detectors are logically ANDed. That is, if two detectors detect a fire, it means that a fire is detected in the cabinet, and the automatic fire extinguisher is activated.

C. The battery cabinet shall reserve a pressure relief port to balance the pressure difference between inside and outside the station when the gas fire extinguisher is started.

### (2) Operation and maintenance projects

Monthly review of projects

A. Check whether there is any fault information in the fire protection;

B. Make a complete test of the fire control system;

C. No abnormal change in the appearance of the equipment;

D. Normal working status;

E, the circuit and instrument indicators are normal;

F. The labels and signs are in good condition;

The G temperature detector is working normally.

## 9.4 Hot system management and operation

### (1) product presentation

Air-cooled chiller is composed of refrigeration cycle system and coolant circulation system. The specific components are compressor, condenser, external circulation fan, throttle element, plate heat exchanger, circulating water pump, electric heater, two and three level pipeline, etc.

### (2) Operation and maintenance repair project

#### A. Electrical maintenance

The appearance is checked every six months to check whether the circuit connection is loose and whether the circuit is rusted. The following items need to be checked during maintenance:

1. Conduct electrical insulation test of the whole machine and find unqualified contacts;

2. (If there is) check whether the contactor is flexible, and whether there is arc and burn mark on the contact;

3. Dust removal of electrical and control components with brush or dry compressed air;

4. Tighten all electrical contacts;

5. (If there is) check the temperature rise of each circuit breaker and contactor contact;

#### B、 routine maintenance

1) Daily maintenance

Maintenance item	Maintenance standards	Detection mode	Exception handling
service data	<p>Current, voltage and inlet and outlet of the unit during operation</p> <p>Water temperature/pressure and other data comply with the following range</p> <p>Circling:</p> <p>A. Current: less than the maximum operation marked on the nameplate</p> <p>Running current</p> <p>B. Voltage: 220V ±15%</p> <p>C. Coolant operating temperature range:</p> <p>-30° C~55° C</p>	visualization	<p>The inlet and outlet water temperature and pressure can be viewed in Figure 5-4 gain .</p> <p>In case of data exception, please refer to "7 Fault Management"</p> <p>Perform fault location and related processing.</p>
Running sound	<p>There is no abnormal vibration and noise in the operation of the unit, main</p> <p>Observe the operation of the following components:</p> <p>a. compression engine</p> <p>b. fan</p> <p>c. circulating water pump</p>	Visual + Auditory	<p>Refer to the "Fault alarm" for abnormal operation</p> <p>Perform fault location.</p>
Pipeline reliability	<p>There is no refrigerant leakage in the refrigeration system.</p> <p>The cooling liquid circulation system is leak-free.</p>	visualization	<p>Refer to the repair pipe after maintenance</p> <p>Fill coolant.</p>
Unit appearance	The surface of the unit is clean and dust-free	visualization	Use brush or cotton cloth to remove dust and dirt from the unit.

2) Regular check-ups

Maintenance item	Maintenance standards	Detection mode	Exception handling	Maintenance cycle
Fan operation reliability	The fan is dust-free and no foreign matter is blocked at the air outlet	visualization	Use a brush to clean it at least one minute after the power is cut off  Clean the dust off the fan. Clean the air outlet a foreign body.	6 months
	The fan blade is not damaged, and the rotating fan runs smoothly without abnormal noise	visualization	Turn off the fan for at least one minute  Tighten, check for internal cables and other dry  Fan rotation involved.  If the fan is faulty, replace it.	6 months
Junction panel power cable Cable, power terminal reliability	Electrical cables and terminals	visualization	Use a screwdriver at least one minute after the power is cut off  Loosen the cable and tighten it.	6 months
	The electrical cable is not aging, broken, abnormal heating or other abnormalities	visualization	Change the power cord after a power outage of at least one minute  cable .	6 months
	No dust on the wiring panel	visualization	Clean with a brush at least one minute after the power is cut off  Clean the dust.	6 months
Condenser cleaning	The condenser is not blocked by dust and foreign matter	visualization	Use compressed air after a power outage of at least one minute  A vacuum with air or a brush head condenses  The equipment is cleaned.	6 months
	The fin is not severely bent or deformed	visualization	Use a fin comb after the power is cut off for at least one minute  The tool is calibrated.	6 months
coolant liquid	a. The concentration meets the range requirements  b. pH and electrolyte concentration meet the requirements  c. No dirt, sediment and algae are produced	a. Coolant detector  b. visualization	Change the coolant after a power outage of at least one minute.	6 months

## 10 Processing specification

Batteries must be disposed of in accordance with the applicable regulations for used batteries. If any battery is damaged, immediately stop using it and contact your installation team or sales partner before disposal. Keep batteries dry and protected from direct sunlight. Ensure prompt handling by your installation team or manufacturer.

1. Batteries (including rechargeable batteries) shall not be treated as household garbage. You are legally obliged to return used batteries.
2. Used batteries may contain pollutants that can damage the environment or your health if improperly stored or disposed of.
3. Batteries also contain important raw materials, such as iron, zinc, manganese, copper, cobalt or nickel, that can be recycled.
4. Please do not throw the battery in the household garbage!



## 11 Warranty policy or description

We promptly address product defects and quality issues through timely solutions. When products malfunction, we provide long-term solutions to ensure complete resolution of technical problems and restore normal operation. For cases requiring replacement of entire units or components, we guarantee shipment within three (3) working days from the date of solution implementation.

Timely recall of related products when there are major defects in performance, design, manufacturing process and reliability.

When the product does not meet the quality standards, we will provide unconditional replacement or return service at our own expense according to customer instructions.

During the product warranty period and within three (3) years after the expiration of the warranty period, software updates will continue to be provided to repair defects in the software and provide applicable new functions.

For any software update of the product, we will provide update notice, explaining the specific content of the update and other information requested by customers.

Assist customers to conduct regular product inspection at least once a year, including providing customers with reasonable and feasible inspection plan and checklist in line with product characteristics and project conditions, as well as other necessary technical support.

## 12 After-sale service

Assist customers to complete product acceptance and delivery according to their needs.

Assist customers to complete the installation and debugging of products. "Product installation and debugging" includes all on-site installation, debugging, testing, testing and other work related to products.

Assist customers to carry out joint commissioning and system acceptance of the main project, ensure that the product is fully compatible with other equipment and components of the main project, and can run normally in the main project.

Handle product quality issues according to customer instructions, including but not limited to product operation faults and compatibility problems between products and main projects and customer products.

Provide technical on-site guidance and support to customers on other product related issues.

Within one week after delivering the specific product to the customer, submit the installation and debugging plan of the corresponding product to the customer. The installation and debugging plan shall be clear, complete and non-misleading, so that experienced installers can complete the installation and debugging properly, safely and within a reasonable time.

In principle, customers are responsible for completing the installation and commissioning of products themselves, with our company providing technical guidance. Upon request, we offer remote assistance through phone consultations, video sessions, or on-site support to assist with product setup and debugging.

## 13 Contact

### EMEA

Service email: [service.EMEA@solplanet.net](mailto:service.EMEA@solplanet.net)

### APAC

Service email: [service.APAC@solplanet.net](mailto:service.APAC@solplanet.net)

### LATAM

Service email: [service.LATAM@solplanet.net](mailto:service.LATAM@solplanet.net)

AISWEI Technology Co., Ltd.

Hotline: +86 400 801 9996

Add.: No. 18, Alley 600, Nanchezhan Road, Huangpu District, Shanghai, China

<https://solplanet.net/contact-us/>



AISWEI Technology CO., Ltd