



OXFORD™

SERIES | SÉRIE

OWNER'S MANUAL

SFH AGRICULTURAL UNIT HEATER

SFH 0521DIS
SFH 0521TDIS
SFHGX 0521TDIS



INS-SFH-0522

THANK YOU FOR YOUR PURCHASE!
NEED ASSISTANCE? CONTACT STELPRO CUSTOMER SERVICE.

WWW.STELPRO.COM
CONTACT@STELPRO.COM
1-844-STELPRO

IMPORTANT INSTRUCTIONS

WARNING

When using electrical appliances, basic precautions should always be followed to reduce the risk of fire, electric shock and injury to persons, including the following:

1. Read all instructions before using this heater.
2. This heater contains hot parts that generate electric arcs or sparks. To avoid burns, do not let bare skin touch hot surfaces. Do not use it in areas where gasoline, paint, or flammable liquids are used or stored.
3. Extreme caution is necessary when the heater is used by or near a child or invalids and whenever the heater is left operating and unattended.
4. Do not operate the heater after it malfunctions. Disconnect power at service panel and have heater inspected by a reputable electrician before reusing.
5. Do not use outdoors.
6. To disconnect heater, turn controls off, and turn off power to heater circuit at main disconnect panel.
7. Do not insert or allow foreign objects to enter any ventilation or exhaust opening in any manner.
8. To prevent a possible fire, do not block air intakes or exhaust in any manner.
9. A heater has hot and arcing or sparking parts inside. Do not use it in areas where gasoline, paint or flammable vapors or liquids are used or stored. Store it in a dry place when not using it.
10. Use this heater only as described in this manual. Any other use not recommended by the manufacturer could cause fire, electric shock or serious injury to persons.
11. Protect the heater with the appropriate circuit breaker or fuse, in accordance with the nameplate.
12. Make sure the line voltage (volts) is consistent with the one indicated on the unit's nameplate.
13. This unit must be grounded.
14. This heater must be installed by a qualified person and connected by a certified electrician in accordance with the electrical and building codes in effect in your area.
15. Observe the distances and positions mentioned in the installation section of this guide.
16. All units must be installed at a minimum height of 6 ft (1.83 m) from the floor and a minimum distance of 6 in. (15 cm) from vertical surfaces or walls (see installation section). Do not allow combustible materials to come into contact with the unit and keep them at least 24 in. (61 cm) from it, as they may ignite more easily than adjacent surfaces. Furthermore, certain materials are more sensitive to heat than others, you must assure that these materials are located at a proper proximity where they can handle the heat released.
17. If the installer or user modifies the heater, they will be held responsible for any damage resulting from this modification, and the product certification may be voided.
18. This heater must not come into contact with water and must be protected from splashes. Do not use it if any part has been submerged.
19. When attaching the heater, make sure that the anchor can support the total weight of the unit plus the weight of the mounting brackets.
20. When cutting or drilling into a ceiling to install the heater, make sure not to damage electrical wiring and other hidden utilities.
21. When starting up the heater for the first time or after a long period, it is normal that it produces some temporary odours and whitish smoke.

Recommended heating capacity: 1.25 W/cubic foot (0.03 m³). This is equivalent to 10 W/square foot (0.09 m²) for a standard ceiling height of 8 feet (2.44 m). The recommended power is usually sufficient for normal heating needs. Please note that the quality of insulation of walls and windows is a factor that influences heat loss and impacts the power required to heat a room. If necessary, refer to a specialist (in industrial and commercial buildings) who can calculate these heat losses and determine the optimal power required or consult the Stelpro website. If the power of the unit is insufficient for the size of the room, it will run continuously, causing it to age prematurely.

Note: When part of the product's technical specifications need to be modified to improve handling or other functions, priority is given to the product's technical characteristics. In this case, the instructions may not fully correspond to all the product functions presented. Therefore, the product and its packaging, as well as its name and illustration, may differ from those presented in this manual.

SAVE THESE INSTRUCTIONS

INSTALLING THE UNIT HEATER

TAKE A FEW MINUTES TO READ THE FAN HEATER'S INSTALLATION GUIDE TO ENSURE AN EASY AND SAFE INSTALLATION.

WHAT'S IN THE BOX

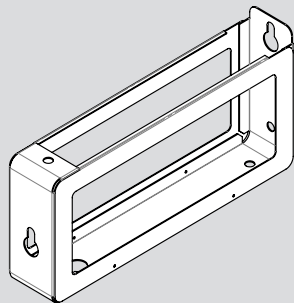

Support

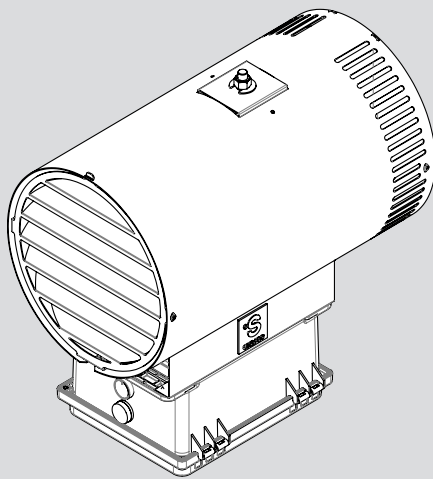

Unit heater

Note: The unit and bracket weigh a total of 35 lbs (16 kg).

TOOLS AND MATERIAL REQUIRED

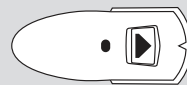

Stud finder

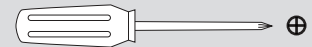

Phillips No. 2 screwdriver



Measuring tape

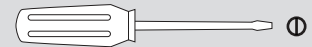

Flat screwdriver 1/4 x 6 in. (15 cm) maximum

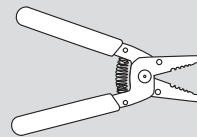

Wire stripper



Ratchet with 1/2 in. socket



Level



Cable and sealed connector for electrical connection and necessary tools.



Two (2) 1/2" hex head lag bolt 1 1/2" (38 mm) long or equivalent hardware to secure the unit heater installation bracket.

CONTROL AND COMPATIBILITY

SFH0521DIS

Use a wall line volt thermostat compatible for 5 kilowatts of heating to control this model.

SFH0521TDIS
SFHGX0521TDIS

These models have a built-in thermostat.

1

UNIT HEATER LOCATION

CAUTION: To avoid any risk of overheating and fire, leave a minimum of 24 in. (60 cm) of free space under the unit and 6 in. (15 cm) on each side of the unit.

This unit meets CSA and UL standards and can be used in Category 1 and 2 locations (locations where corrosive vapors or liquids or excessive humidity may be present). Section 22-002 of the Canadian Electrical Code.

WARNING: Unit heater installation must be done by a certified electrician in accordance with the electrical and building codes in your area.

You must install your heater in an open area at least 6 ft (1.83 m) from the floor and at a maximum height of 10 ft (3 m).

Make sure that objects or furniture near the heater can withstand the heat it gives off.

To install your unit heater:

- Consider the location of the studs in your ceiling. The mounting bracket of the heater must be attached to a stud.
- Consider the location of pipes, electrical wires or other components that may be present inside the ceiling and damaged during installation.

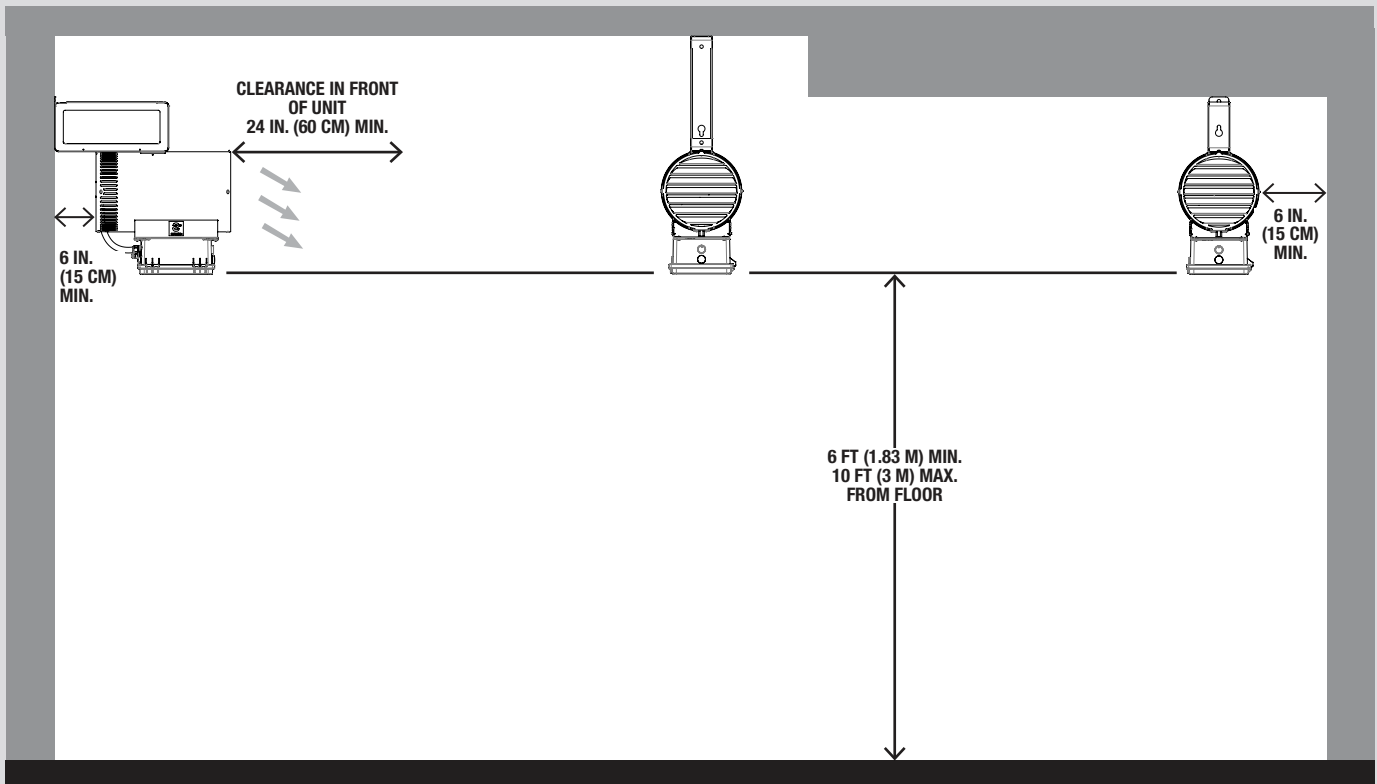

WARNING: This product must be installed by a certified electrician according to the electrical and building codes effective in your region.

2

TURNING OFF THE POWER SUPPLY

To protect yourself against the risk of electric shock, disconnect the power supply to the cables at the electrical panel.

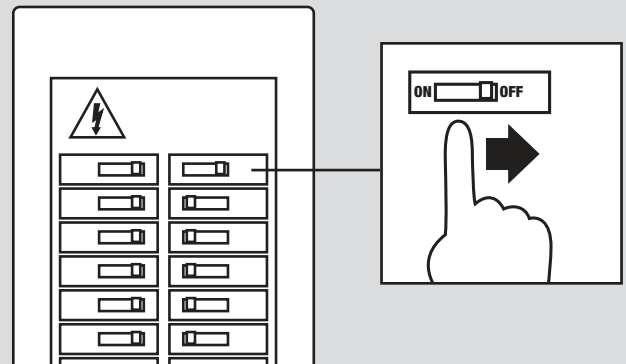

3

ATTACHING THE BRACKET

1. Using a stud detector, locate studs and other structures in the ceiling or wall.
2. Determine the location of the unit according to the instructions in Section 1 on page 4. Measure and tag the space required according to the diagrams below.
3. Attach the bracket **[A]** securely using two $\frac{1}{2}$ x $1\frac{1}{2}$ " lag bolts (not supplied) or equivalent hardware that can support the weight of the unit and its 35 lb (16 kg) bracket. Make sure the bracket is level.

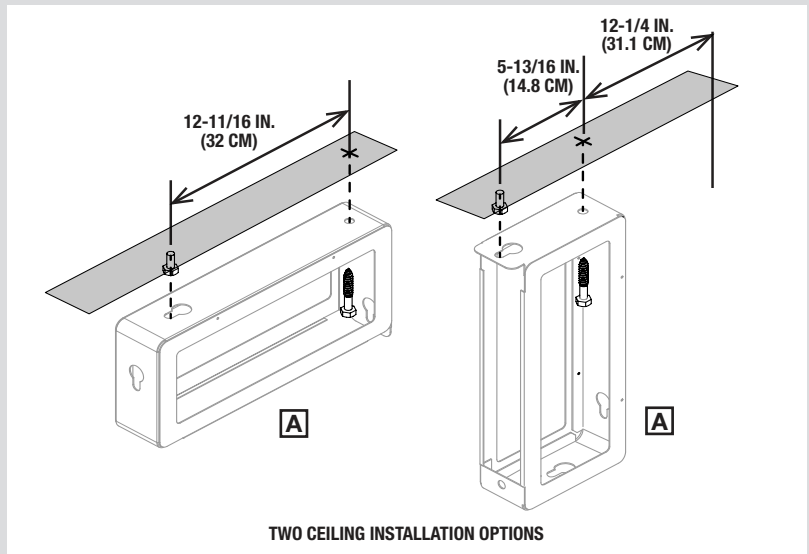
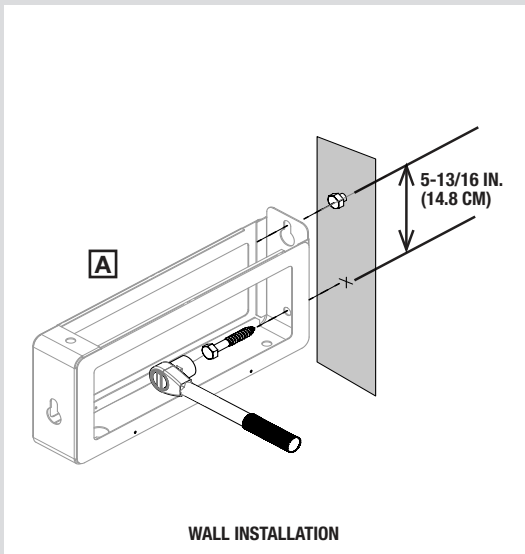

4

ATTACHING THE UNIT TO THE BRACKET

1. Using a ratchet wrench with a $\frac{1}{2}$ in. socket, loosen the nut **[A]** on the top of the unit and release the slotted washer **[B]**.
2. Lift the unit to insert the nut into the bracket mounting hole **[C]** and make sure that the screw is securely locked into the notch.
3. Push the unit upwards and insert the slotted washer **[B]** between the bracket and the nut.
4. Position the unit in the desired direction, making sure to follow the specifications in Section 1 on page 4. While holding the unit in place, tighten the nut firmly to secure the unit.

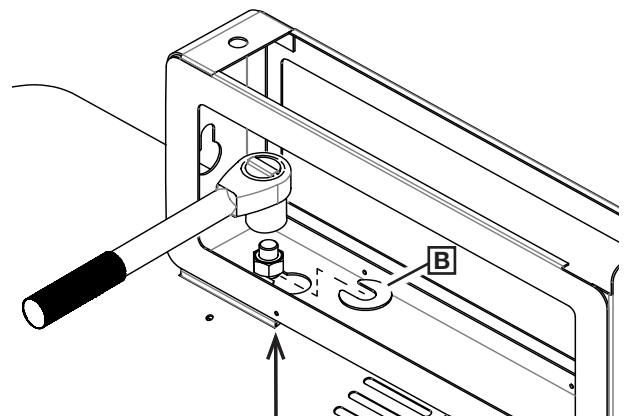
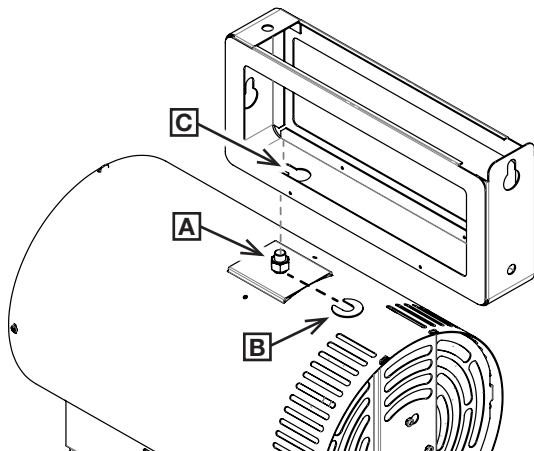

5

CONNECTING THE ELECTRICAL WIRES

1. With a flat or Philips screwdriver, unscrew the two screws **[A]** to open the junction box cover.

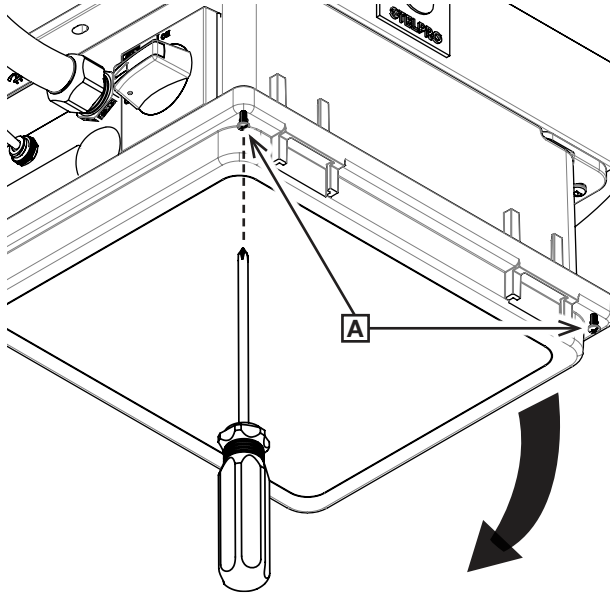

2. Using a flat screwdriver, remove the protective cap **[B]** to unblock the opening that will be used to insert the power cables.

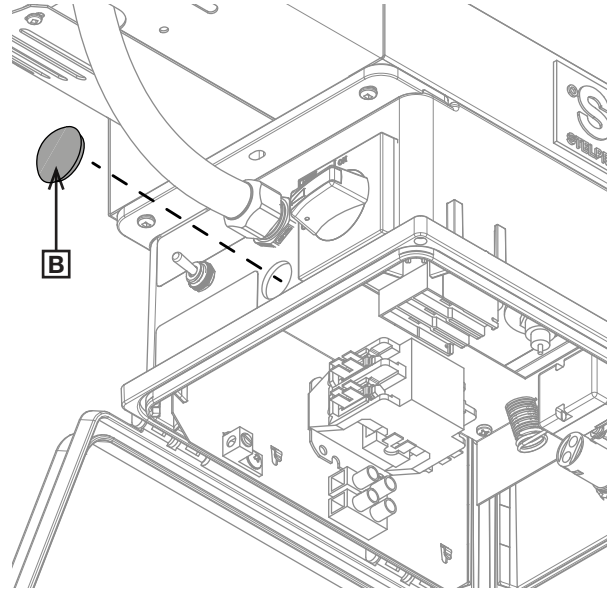

3. Install a sealed connector **[C]** (not included) in the opening and insert the power cables into it, making sure to leave 6" (15 cm) of wire in the junction box.

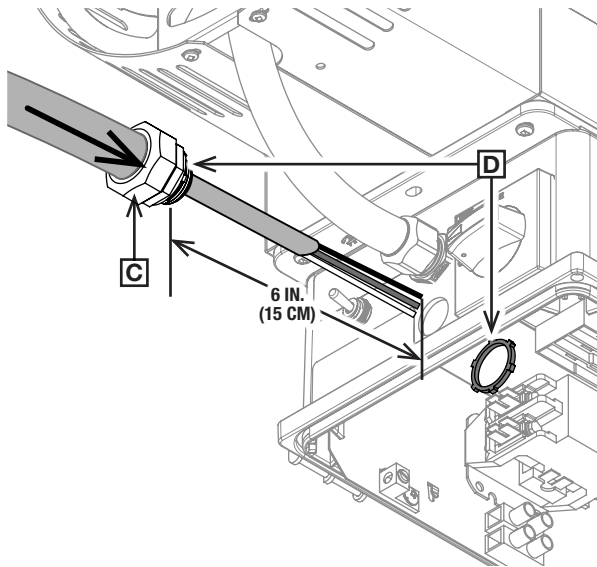

4. Tighten the connector nuts **[D]** tightly to secure the connection.

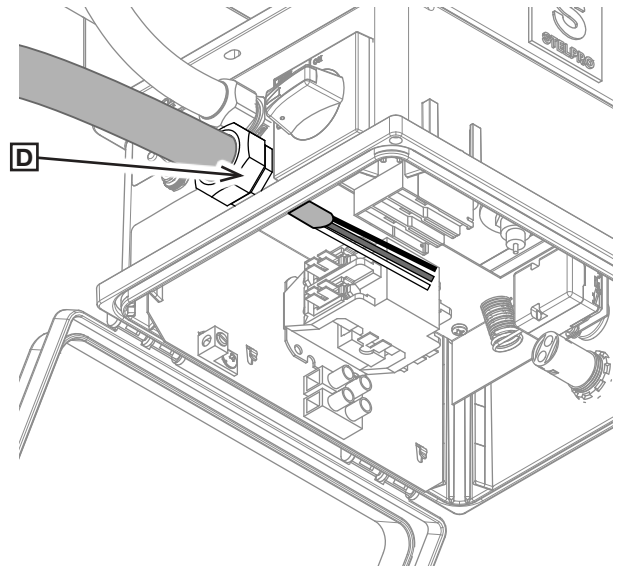

- Connect the power supply and thermostat wires according to the diagram that applies to your situation. Leave the central terminal on the circuit breaker [E] free.
- Tighten the terminal screws firmly to ensure a secure connection.

- Close the cover and tighten the screws securely.

Note: You'll need a 1/4" x 6" flat screwdriver to access the screws on the circuit breaker terminals [E]. See the footnote if you do not have this tool on hand.

FOR A DEVICE WITH A BUILT-IN THERMOSTAT
(SFH0521TDIS OR SFHG0521TDIS)

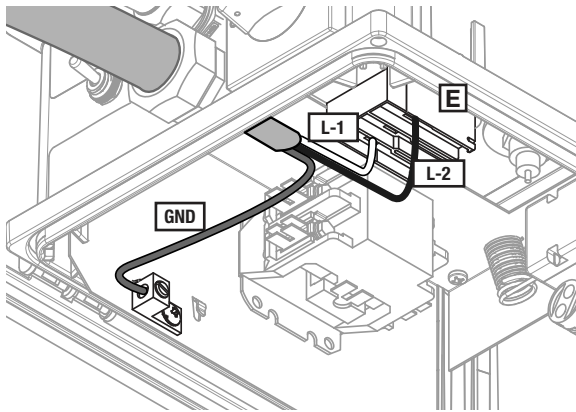

CIRCUIT DIAGRAM

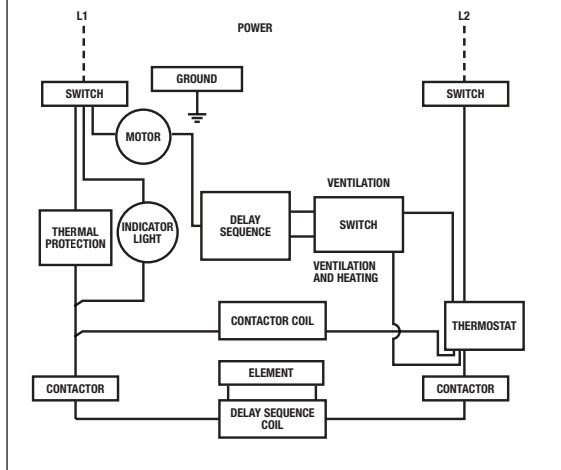

FOR A DEVICE WITHOUT A BUILT-IN CONTROL
(SFH0521DIS)

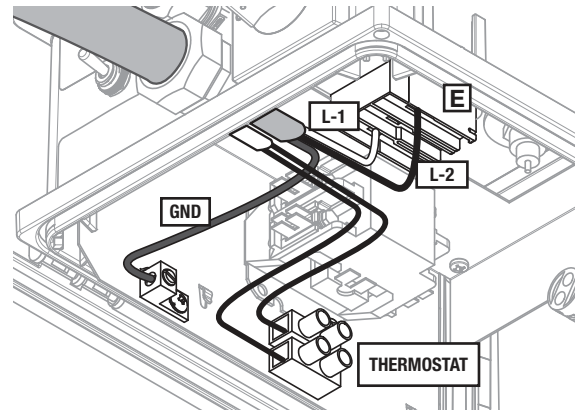

CIRCUIT DIAGRAM

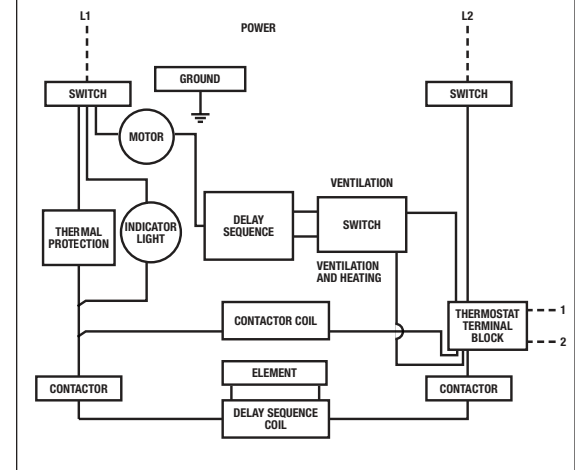

TIPS TO EASILY CONNECT THE MAIN CIRCUIT BREAKER

- Press on the button [F] located behind the circuit breaker [E] to release the lock, then hold it down.
- Pull on the circuit breaker [E] firmly to release it from the button's metal pin. Connect the power supply wires to the circuit breaker.
- Put everything back in place by pushing the circuit breaker onto the button's pin. Check the sturdiness of the connection.

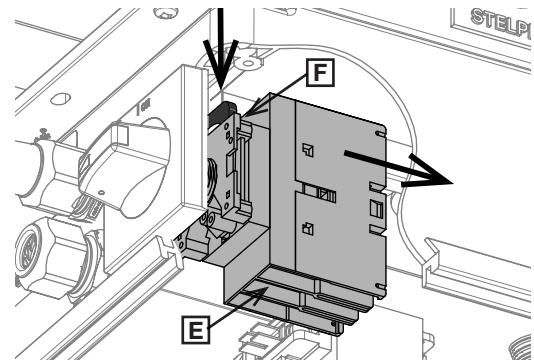

6

RESTORING POWER

Restore power to the unit heater. Make sure it works by increasing the thermostat temperature set point until the unit starts to heat.

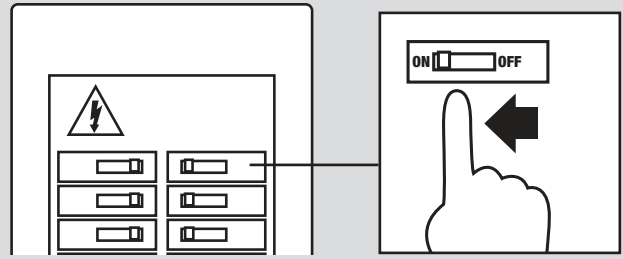

UNIT CONTROL AND OPERATION

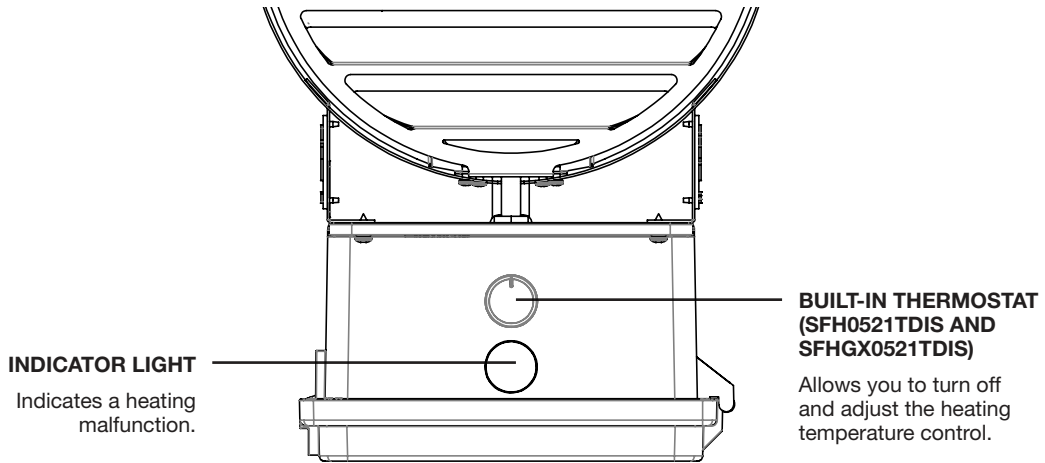

FRONT

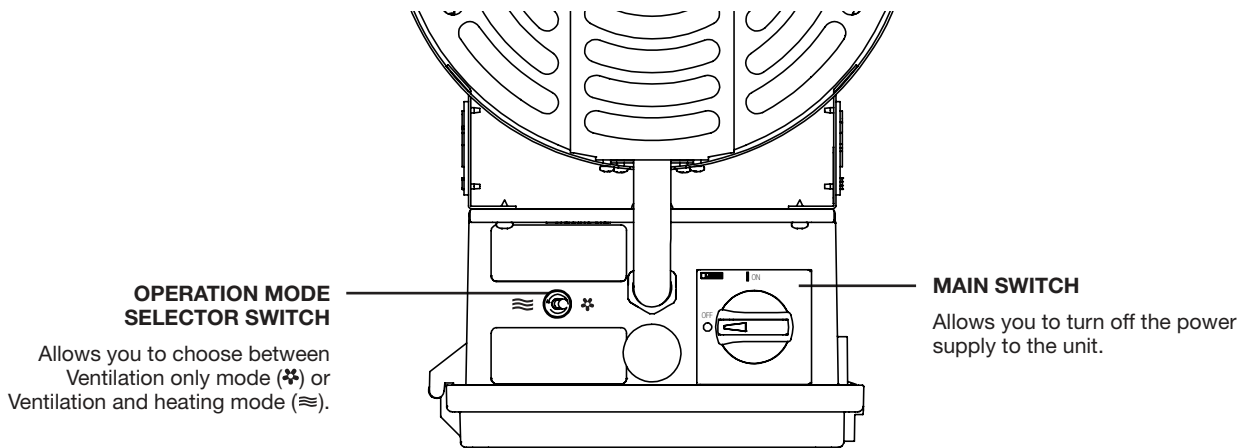

BACK

NOTE: The unit has a time-delay feature to cool the heating elements after the setpoint has been reached.

MAINTAINING THE FAN HEATER

THE UNIT HEATER'S AIR INLET AND OUTLET MUST BE CLEANED REGULARLY FOR THE WARRANTY TO BE VALID.

WARNING: Turn off the power to the unit heater directly from the electrical panel before cleaning. Even when it is not heating, the fan heater remains powered on and can cause an electric shock.

Dust the unit with a soft cloth and clean it with a damp cloth only. If you use cleaning products, they could damage the unit heater.

If the unit is in a very dusty area, use a vacuum cleaner with a dust brush to remove dust and other foreign matter from the unit.

The unit heater is water resistant and can be hosed down to help cleaning.

During maintenance, never use the following:

- Metal brush or scouring pad
- Chlorine
- Cleaning products containing abrasives
- Hydrochloric-acid based products, such as bleach
- Any other cleaning product with the following symbols:



TROUBLESHOOTING THE UNIT HEATER

The following table lists the most common problems and alerts you may encounter with your unit heater.

If your issue isn't listed in this table or if the proposed solution does not solve the problem, please turn off the unit and contact our customer service team.

WWW.STELPRO.COM
CONTACT@STELPRO.COM
1-844-STELPRO

PROBLEMS/ALERTS	POSSIBLE CAUSES AND SOLUTIONS
The unit does not start up after it is installed.	<ul style="list-style-type: none"> • Make sure that the setpoint is not too low. • Make sure that the unit heater wires are properly connected. Refer to <i>Connecting the electrical wires on page 7</i>. • Make sure that the circuit breaker that corresponds to the heating system on the electrical panel is switched ON as well as the unit's main switch. • If the problem persists, the thermostat may be defective. Please contact STELPRO Customer Service.
The circuit breaker trips when the unit heater is switched on.	<ul style="list-style-type: none"> • Make sure the fan heater's wires are connected correctly. Refer to <i>Connecting the electrical wires section on page 7</i>. • Make sure the electrical voltage supplied corresponds to that indicated on the nameplate. • Make sure that the circuit-breaker or fuse is adequate for the power required.
The setpoint temperature is never reached.	<ul style="list-style-type: none"> • Make sure that the electrical voltage supplied corresponds to the voltage indicated on the nameplate. • Make sure that the unit is powerful enough for the size of the room. • The unit is overheating, and the thermal protection has been triggered. Make sure that the unit's air inlet and outlet are not obstructed. If the cause of the overheating has been corrected, the unit will start working again after a few minutes. • If the unit is controlled by a wall thermostat, make sure it is not defective. • If none of the above solutions solve the issue, one or more of the heating elements may be defective. Contact STELPRO Customer Service.
The unit operated continuously.	<ul style="list-style-type: none"> • Make sure that the unit is powerful enough for the size of the room. • If the unit operates continuously, the thermostat may be defective. Please contact STELPRO Customer Service.
The ambient temperature is too high.	<ul style="list-style-type: none"> • Make sure that the setpoint is correct. • If the problem persists, the thermostat may be defective. Please contact STELPRO Customer Service.
The unit isn't heating.	<ul style="list-style-type: none"> • Make sure that the setpoint is not too low. • Make sure that the unit heater wires are properly connected. Refer to <i>Connecting the electrical wires on page 7</i>. • The unit is overheating, and the thermal protection has been triggered. Make sure that the unit's air inlet and outlet are not obstructed. If the cause of the overheating has been corrected, the unit will start working again after a few minutes. (For an SFHGX0521TDIS unit, see <i>Restoring the thermal protection on page 11</i> to restart the unit.) • If the problem persists, the thermostat or one of the heating elements may be defective. Please contact STELPRO Customer Service.
The indicator light is on.	<ul style="list-style-type: none"> • The unit is overheating, and the thermal protection has been triggered. Make sure that the unit's air inlet and outlet are not obstructed. If the cause of the overheating has been corrected, the unit will start working again after a few minutes. (For an SFHGX0521TDIS unit, see <i>Restoring the thermal protection on page 11</i> to restart the unit.)

1

RESTORING THE THERMAL PROTECTION (SFHGX0521TDIS ONLY)

In the event of overheating or a power failure, the thermal protection may be triggered.

1. Set the main switch to OFF to turn off the power to the unit before proceeding.
2. Using a flat or Philips screwdriver, remove the two screws **[A]** to open the junction box cover.

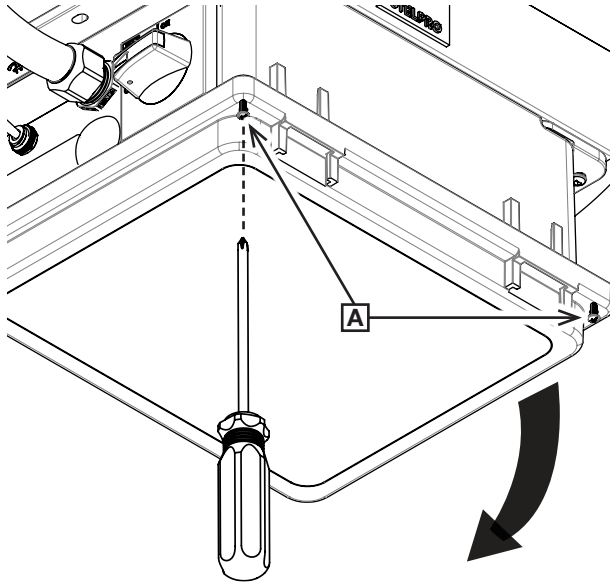

3. Press the button **[B]** at the centre of the thermal protection. Close the cover and secure it with the screws. Turn the power back on. The indicator light should be off to indicate that the thermal protection is working again.

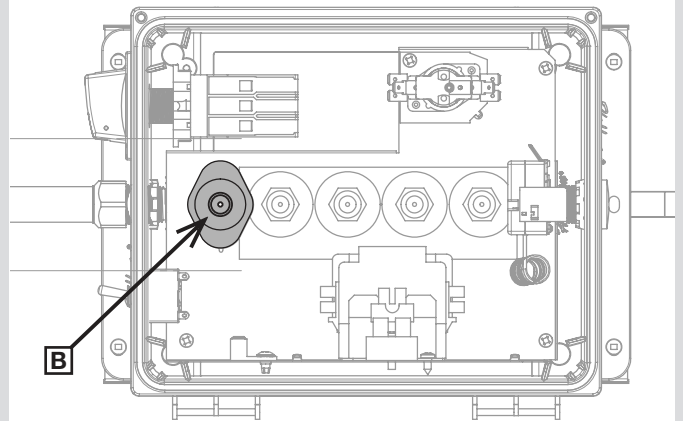

STELPRO LIMITED WARRANTY

This limited warranty is offered by STELPRO Design Inc. ("STELPRO") and applies to the following product made by STELPRO: model **SFH**.

Please read this limited warranty carefully. Subject to the terms of this warranty, STELPRO warrants its products and their components against defects in workmanship and/or materials for the following periods from the date of purchase: **3 years**. This warranty applies only to the original purchaser; it is non-transferable and cannot be extended.

CLAIM PROCEDURE

If at any time during the warranty period the unit becomes defective, you must cut off the power supply at the main electrical panel and contact 1) your installer or distributor, 2) your service center or 3) STELPRO's customer service department. In all cases, you must have a copy of the invoice and provide the information written on the product nameplate. STELPRO reserves the right to examine or to ask one of its representatives to examine the product itself or any part of it before honoring the warranty. STELPRO reserves the right to replace the entire unit, refund its purchase price or repair a defective part. Please note that repairs made within the warranty period must be authorized in advance in writing by STELPRO and carried out by persons authorized by STELPRO.

Before returning a product to STELPRO, you must have a STELPRO authorization number (RMA). To obtain it, call the customer service department at: 1-844-STELPRO. The authorization number must be clearly written on the parcel or it will be refused.

CONDITIONS, EXCLUSIONS AND DISCLAIMER OF LIABILITY

This warranty is exclusive and in lieu of all other representations and warranties (except of title), expressed or implied, and STELPRO expressly disclaims and excludes any implied warranty of merchantability or implied warranty of fitness for a particular purpose.

STELPRO's liability with respect to products is limited as provided above. STELPRO shall not be subject to any other obligations or liabilities whatsoever, whether based on contract, tort or other theories of law, with respect to goods or services furnished by it, or any undertakings, acts or omissions relating thereto. Without limiting the generality of the foregoing, STELPRO expressly disclaims any liability for property or personal injury damages, penalties, special or punitive damages, damages for lost profits, loss of use of equipment, cost of capital, cost of substitute products, facilities or services, shutdowns, slowdowns, or for other types of economic loss or for claims of a dealer's customers or any third party for such damages. STELPRO specifically disclaims all consequential, incidental and contingent damages whatsoever.

This warranty does not cover any damages or failures resulting from: 1) a faulty installation or improper storage; 2) an abusive or abnormal use, lack of maintenance, improper maintenance (other than that prescribed by STELPRO) or a use other than that for which the unit was designed; 3) a natural disaster or an event out of STELPRO's control, including, but not limited to, hurricanes, tornadoes, earthquakes, terrorist attacks, wars, overvoltage,

flooding, water damages, etc. This warranty does not cover any accidental or intentional losses or damages, nor does it cover damages caused by negligence of the user or owner of the product. Moreover, it does not cover the cost of disconnection, transport, and installation.

The warranty is limited to the repair or the replacement of the unit or the refund of its purchase price, at the discretion of STELPRO. Any parts replaced or repaired within the warranty period with the written authorization of STELPRO will be warranted for the remainder of the original warranty period. This warranty will be considered null and void and STELPRO will have the right to refuse any claims if products have been altered without the written authorization of STELPRO and if the nameplate numbers have been removed or modified. This warranty does not cover scratches, dents, corrosion or discoloration caused by excessive heat, chemical cleaning products and abrasive agents. It does not cover any damage that occurred during the shipping.

Some states and provinces do not allow the exclusion or limitation of incidental or consequential damages and some of them do not allow limitations on how long an implied warranty lasts, so these exclusions or limitations may not apply to you. This warranty gives you specific legal rights and you may have other rights which vary from state to state or from province to province.