



118L Outdoor Beverage Chiller



Model Number SOBF118

INSTRUCTION MANUAL

IM Version No.: V1.4

Issue Date: 10/2018

AFTER SALES SUPPORT

  1300 11 43 57

 support@residentiagroup.com.au

MODEL: SOBF118 | PRODUCT CODE: 62575 | 10/2018



E2447

Welcome

Congratulations on choosing to buy a STIRLING® product.

All products brought to you by STIRLING® are manufactured to the highest standards of performance and safety and, as part of our philosophy of customer service and satisfaction, are backed by our comprehensive 3 Year In Home Warranty. We hope you will enjoy using your purchase for many years to come.

Contents

- 2 Welcome**
- 4 Warranty**
- 5 General Safety Instructions**
- 7 Product Overview**
- 9 Getting Started**
- 9 Installation**
- 11 Specifications**
- 12 Instructions**
- 14 FAQs and Troubleshooting**
- 15 Other Useful Information**
- 18 Repair and Refurbished Goods or Parts Notice**
- 19 Warranty Returns**



STIRLING®

118L OUTDOOR BEVERAGE CHILLER

Warranty Details

REGISTER YOUR PURCHASE AT www.aldi.com.au/en/about-aldi/product-registration/ TO KEEP UP-TO-DATE WITH IMPORTANT PRODUCT INFORMATION

The product is guaranteed to be free from defects in workmanship and parts for a period of 36 months from the date of purchase. Defects that occur within this warranty period, under normal use and care, will be repaired, replaced or refunded at our discretion. The benefits conferred by this warranty are in addition to all rights and remedies in respect of the product that the consumer has under the Competition and Consumer Act 2010 and similar state and territory laws.

Our goods come with guarantees that cannot be excluded under the Australian Consumer Law. You are entitled to a replacement or refund for a major failure and for compensation for any other reasonably foreseeable loss or damage. You are also entitled to have the goods repaired or replaced if the goods fail to be of acceptable quality and the failure does not amount to a major failure.



General Safety Instructions

IMPORTANT SAFETY INSTRUCTIONS READ CAREFULLY AND KEEP FOR FUTURE REFERENCE

Read this manual thoroughly before first use, even if you are familiar with this type of product. The safety precautions enclosed herein reduce the risk of fire, electric shock and injury when correctly adhered to. Make sure you understand all instructions and warnings.

Keep the manual in a safe place for future reference, along with the completed warranty card and purchase receipt. If you sell or transfer ownership of this product, pass on these instructions to the new owner.

Always follow basic safety precautions and accident prevention measures when using an electrical appliance, including the following:

WARNING: This is a beverage chiller, this is not intended to be used to preserve or store fresh food or consumables.

A beverage chiller is designed for the storage of cans/bottles at a set temperature that is particularly suitable for the drinks. The temperature maintained in this beverage chiller is too high for safe storage of perishable foods.

Electrical Safety

- **Voltage:** Before connecting and turning on the beverage chiller, ensure the electrical voltage and circuit frequency correspond to that indicated on the appliance rating label.
- **Earthing:** This beverage chiller should be properly earthed for your safety. The power cord of this beverage chiller is equipped with a three-prong plug for use in standard wall outlets to minimise the possibility of electrical shock. Do not modify the cord and/or plug provided with the appliance. Improper use of the earthed plug can result in the risk of electric shock.
- **Connection:** This beverage chiller requires a standard 220-240 V AC 50Hz electrical outlet. Do not overload the electrical circuit.
- **Power cord:** Do not kink or damage the power cord; do not leave it exposed or dangling. Secure it at the back of the appliance so no one steps on or places anything on the cord or against it. Keep the cord out of reach of children. When moving the appliance, make sure not to damage the power cord.
- **Auxiliary Items:** Do not use an inverter, adaptor or extension cord with this beverage chiller. If the cord is too short, have a qualified electrician install an outlet near the appliance. Use of an extension cord and an inverter can negatively affect the performance of the unit.
- **Protect from moisture:** To protect against the risk of electric shock, do not immerse the unit, cord or plug in water or spray it with any other liquid. Do not connect or disconnect the electric plug when your hands are wet. Turn the power switch off before removing the plug from the socket.
- **WARNING: Disconnect!** To reduce the risk of fire, electric shock or personal injury, always unplug the appliance from the socket when not in use, when moving and before cleaning or servicing. Never unplug the unit by pulling the power cord. Always grip the plug firmly and pull straight out from the power point.
- **Electrical work:** Any electrical work required for the installation of this appliance should be carried out by a qualified electrician.

Usage Conditions and Restrictions

- **Domestic use only:** This beverage chiller is intended for indoor or outdoor household use only. It is not intended for commercial or industrial use.
- **Purpose:** Do not use this beverage chiller for anything other than its intended purpose. Other uses are not recommended and may cause fire, electric shock or personal injury.
- **Attachments:** The use of attachments is not recommended by the appliance manufacturer and distributor as they may be hazardous.
- **Improper use:** Damage due to improper use, or repairs made by unqualified personnel will void your warranty. We assume no liability for any eventual damages caused by misuse of the product or noncompliance with these instructions.

General Safety Instructions Cont.

- **WARNING:** Do not use mechanical devices or other means to accelerate the defrosting process, other than those recommended by the manufacturer.
- **Usage restriction:** This beverage chiller is not intended for use by persons (including children) with reduced physical, sensory or mental capabilities, or lack of experience and knowledge, unless they have been given supervision or instructions concerning use of the appliance by a person responsible for their safety.
- **Children:** Supervise young children to ensure they do not play with the appliance. Never allow children to operate, play with or crawl inside the beverage chiller.
- **WARNING:** Do not use electrical appliances inside the beverage chiller, unless they are of the type recommended by the manufacturer.
- **Explosive or flammable substances:** Do not store explosive substances such as aerosol cans with a flammable propellant in this beverage chiller. Do not store or use petrol or any other flammable vapours and liquids in the vicinity of this or any other appliance. Do not use such substances for cleaning the beverage chiller. The fumes can create a fire hazard or an explosion.
- **Damage:** Do not use the beverage chiller if the power cord, plug or the beverage chiller itself is damaged. If the cord is damaged, contact the after sales support line and have the cord replaced by qualified personnel in order to avoid a hazard.
- **WARNING:** Do not damage the refrigerant circuit.
- **Do not modify:** Do not attempt to alter or modify this beverage chiller in any way.
- **Repair:** Do not attempt to repair or replace any part of your beverage chiller unless it is specifically recommended in this manual. All other servicing should be referred to a qualified technician. Contact the after sales support line for advice.
- **WARNING:** Keep ventilation openings, in the beverage chiller enclosure or in-built structure, clear of obstruction.



This symbol alerts you to take care as this beverage chiller contains a flammable refrigerant (isobutane) and insulation blowing gas (cyclopentane). Do not expose it to high heat, sparks and open flames.

The refrigerant isobutane (R600a) is contained within the refrigerant circuit of the appliance, a gas with a high level of environmental compatibility, which is nevertheless flammable. During transportation and installation of the beverage chiller, ensure that none of the components of the refrigerant circuit become damaged.

Never use a beverage chiller with a damaged refrigerant circuit! If the coolant circuit becomes damaged, avoid proximity to open fires and all types of heat sources. The room in which the unit is located should be ventilated for a few minutes.

The room for installing the appliance must be at least 1m³ per 8g of refrigerant. The amount and type of refrigerant in the appliance can be found in the technical specifications on page 18 and on the appliance rating plate.

It is hazardous for anyone other than an Authorised Service Person to service this appliance. In Queensland – the authorized Service Person MUST hold a Gas Work Authorisation for hydrocarbon refrigerants, to carry out Servicing or repairs which involve the removal of covers.

Note: If using the beverage chiller outside in an alfresco area ensure that it is directly connected to an outdoor power point and please ensure it is not left in the weather or in direct sunlight. All electrical connections are to be made in a dry area and outdoor power points must be weatherproof and installed by a qualified electrician. The appliance must not be exposed to rain.

Product Overview

118L Outdoor Beverage Chiller



Key:

- A. Electronic Control Panel
- B. Handle
- C. Stainless steel door frame
- D. Light switch
- E. Shelves (x2)
- F. Base with ventilation
- G. Door lock (on front of door)
- H. Levelling Legs (x4)

Also included:

Note: Not pictured

- Shelf supports (x8 + 1 spare), see page 11 for more details
- Keys for door lock (x2), see page 16 for more details

Product Overview Cont.

Control Panel Layout

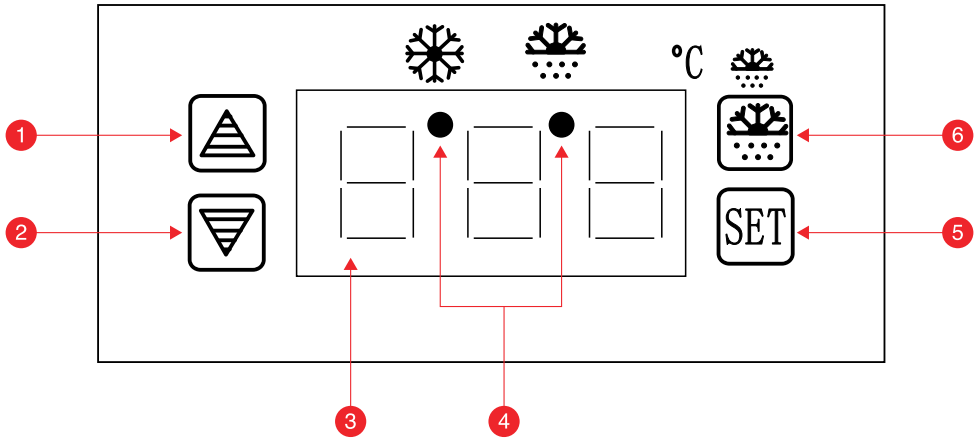

Key:

- 1 Temperature Control: Up Button**
- 2 Temperature Control: Down Button**
Press the Up or Down buttons to increase or decrease the temperature inside the beverage chiller cabinet in 1° intervals. See more on page 12
- 3 LED Display**
- 4 Indicator Lights**
Indicator on the left relates to the Cooling Symbol: ❄️
Indicator on the right relates to the Defrost Symbol: ❄️
See pages 12–13 for more information on these
- 5 Set Temperature Button**
Press this button to set the desired temperature.
See more on page 12
- 6 Defrost Button**
Press this button to manually activate the defrost cycle.
See more on page 12–13

Getting Started

Unpacking

- **Packaging materials:** This beverage chiller has been packaged to protect it against transportation damage. Remove all packaging materials from around and inside the beverage chiller and keep the original packaging carton and materials in a safe place. It will help prevent any damage if the product needs to be transported in the future, and you can use it to store the beverage chiller when it is not in use. In the event the carton is to be disposed of, please recycle all packaging materials where possible.
- **Suffocation:** Plastic wrapping can be a suffocation hazard for babies and young children, so ensure all packaging materials are out of their reach and disposed of safely.
- **Power cord:** Unwind the power cord to its full length and inspect it for damage. Do not use the beverage chiller if it or its cord have been damaged or are not working properly. In case of damage, contact our after sales support line for advice on examination, repair or return of the damaged product.
- **Read the manual:** Read this manual to familiarise yourself with the beverage chiller. Pay particular attention to the safety instructions on the previous pages.
- **Clean:** To remove any dust from transit and storage, clean the interior and exterior surfaces of the beverage chiller with lukewarm water and a soft cloth. Dry thoroughly.

Installation

- **Two person installation:** Use two or more able-bodied people to move and install the beverage chiller. Failure to do so can result in back or other injury.
- **Floor surface:** This beverage chiller must be properly positioned on a dry, sturdy, level surface that is strong enough to support it when it is fully loaded.
- **Location:** We recommend that this beverage chiller is installed in a sheltered location with the required power safely accessible. For example: an alfresco area, under a protected verandah or in a garage. Please ensure it is not left in the weather or in direct sunlight and it is always protected from rain, water or excessive moisture.
- **Tropical Rating:** This rating allows the beverage chiller to be operating effectively in temperatures up to 43° C.

Do NOT install/use the beverage chiller in the following locations/situations:

- In a recreational vehicle, or for use with an inverter.
- In direct sunlight, near heat sources, next to an open flame, cooking or heating appliance, or near any other source of high heat.
- Direct sunlight may affect the acrylic coating and heat sources may increase the unit's power consumption. For best energy efficiency install the beverage chiller in the coolest location within the area it is placed.
- In an area with extreme cold ambient temperatures.
- During camping.
- In an area with excessive moisture and high humidity. Make sure it is protected from elements such as wind, rain, water spray or drips.
- In an area where petrol or other explosive and/or flammable liquids or fumes are used or stored. The fumes can create a fire hazard or explosion.
- **Levelling:** It is important for the beverage chiller to be level in order to work properly. To level the unit, adjust the levelling legs at the bottom of the beverage chiller. See page 15 for more details on this.
- **Ventilation:** To allow for proper air ventilation, leave a minimum 5cm of space between the back, sides and top of the beverage chiller and make sure that the front of the unit is completely unobstructed. Ensure that the ventilation openings are never blocked or covered. Never cover shelves with aluminium foil or any other material, which may prevent air circulation.

Installation Cont.

- **Settling:** Before connecting the beverage chiller to the power source, let it stand upright for approximately 8 hours. This will allow any refrigerant gasses that may have been disturbed during the transportation process to settle and reduce the possibility of a malfunction in the cooling system from handling during transport.
- **Electrical connection:** You should check whether there is an electrical socket available, which will be accessible after your appliance is installed. Plug the beverage chiller into a dedicated, properly installed wall outlet. Do not under any circumstances cut or remove the third (earth) prong from the power cord. Any questions concerning power and/or earthing should be directed toward a licensed electrician or our after sales support centre.
- After plugging the beverage chiller in, turn the unit on and allow it to cool down for 3–4 hours before placing beverages in the appliance.

Positioning and Ambient Temperatures

- This beverage chiller is rated to tropical ambient temperatures. Your beverage chiller may not function correctly if the ambient temperature exceeds 43° C.
- Your appliance should not be located in direct sunlight or exposed to continuous heat or extremes of temperature (e.g. next to a radiator or boiler). If this is not feasible, then you should install an insulation plate between the appliance and the adjacent heat source.
- Place the beverage chiller flatly and firmly on a solid base.
- Anything positioned above the beverage chiller must be at least 5 cm away to allow sufficient cooling of the condenser. You must allow a 5 cm gap to the rear and either side of the appliance.
- Be sure to leave enough space for the opening of the door, to avoid damage to the appliance or personal injury.

Built-in or Freestanding Installation: Your beverage chiller can be used as a freestanding or a built in unit. The clearances shown in the drawing below (Fig. 1) should be followed for both types of installation.

- In particular, the depth dimension must be observed.
IMPORTANT: The vent at the base of the appliance is for ventilation. Nothing should be placed in front of this vent; otherwise your beverage chiller may not operate properly.
- A decorative plinth can be fitted to the front of the base vent as long as the cut out of 512mm wide × 40mm high is made in the plinth.

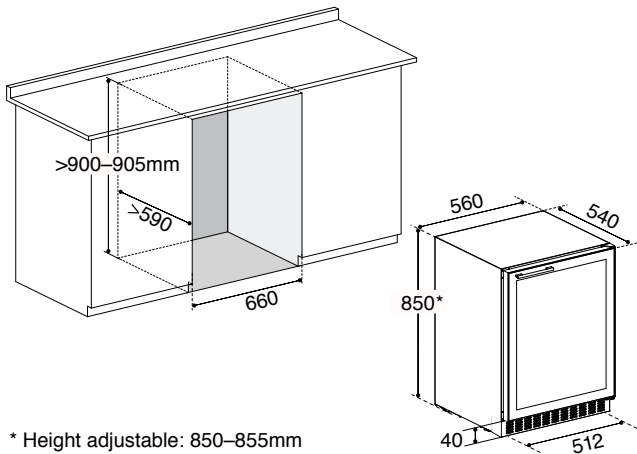

Fig. 1

Installation Cont.

Positioning the Shelves

Position the shelf supports inside the racks on the sides (as illustrated in Fig. 2) at your required level. You can then place the shelves firmly on the supports and begin to load your contents.

Note: The maximum load for a shelf is 40kg.

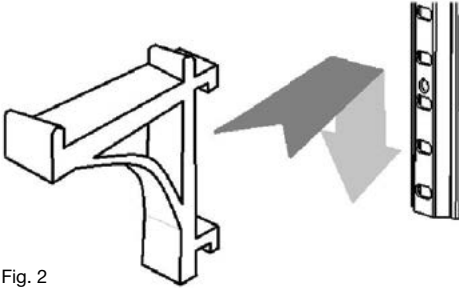

Fig. 2

Specifications

Product Dimensions (H, W, D):	850mm, 560mm, 500mm*	* Handle: +40mm
Weight (Net / Gross):	39kg / 41kg	
Temperature Range:	0–10°C	
IP Rating	IPX4	
Other Features:	Internal LED light	
	Electronic controls	
	Double glazed door	
	Single layer of heated glass**	

**** Note:** Your Stirling Outdoor Beverage Chiller is designed to eliminate any condensation from accumulating on the glass door. This is achieved by heating the outer glass surface of the door slightly. As such, it is normal for the door to feel slightly warm for the touch.

Instructions

- **First use:** After delivery, wait for eight hours before connecting the appliance to your mains supply. This will allow any refrigerant gases that may have been disturbed during the transportation process to settle.
- **First cooling down:** When you first switch on the beverage chiller, the compressor will run continuously until the beverage chiller reaches the set temperature. During this period of time, try not to open the door frequently or place bottles inside the appliance. After about 3–4 hours, you can start loading the beverage chiller.
- **Odour:** You may notice an odour when you first switch on the beverage chiller. This is due to the parts being new and is no cause for concern. The odour will subside as the beverage chiller starts to cool.

IMPORTANT

- When you use the beverage chiller for the first time or restart it after it has been turned off for a long time, there could be a few degrees variance between the temperature you select and the one indicated on the LED display. This is normal and it is due to the length of activation time. Once the beverage chiller has been running for a few hours, everything will return back to normal.
- When loading several bottles or cans at once, it will take longer for the appliance to cool the individual bottles than when adding a bottle at a time.
- If the unit is switched off or unplugged, you must allow at least 5 minutes before restarting the beverage chiller or reconnecting it to your mains supply.



Turning the Appliance On and Off

- When the beverage chiller is connected to the power outlet it will turn on automatically.

Normal Operation

- During normal operation the controller display will show the desired temperature that the beverage chiller is currently set to.
- The small indicator light on the left (under the ❄️ symbol) will illuminate to confirm the beverage chiller is in its normal cooling mode, and compressor is running.

To Set the Desired Temperature

- Press the “SET” () button once. A ‘beep’ will sound, and the display will start to flash.
- Use the “Up” or “Down” ( or ) buttons to set to the desired temperature. Fig. 3
- Press “SET” again to complete the operation. Alternatively, do not press anything for 5–10 seconds and the new desired temperature setting will be saved.

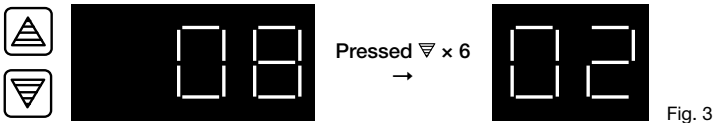

Automatic Defrost

Note: The beverage chiller is built to automatically defrost and prevent any ice forming on the evaporator. The ‘Defrost’ cycle will automatically run for 20 minutes once every 8 hours.

- When in a ‘Defrost’ cycle, the indicator light will illuminate under the ❄️ symbol.

Manual Defrost

- Press the ‘Defrost’ () button and hold it down—a ‘beep’ will sound as soon as it is pressed.
- Hold button down for 6 seconds, until a second ‘beep’ can be heard.
- The indicator light will now illuminate under the ❄️ symbol and the beverage chiller is now in ‘defrost’ cycle.
- ‘Defrost’ will run for 20 minutes, and then automatically revert to normal operation.

Instructions Cont.

Manually Changing Back to Normal Operating Mode from the 'Defrost' Mode

- Press the 'Defrost' (☼) and a 'beep' will sound.
- Hold the button down for 6 seconds, until a second 'beep' is heard.
- Both indicator lights under the ☼ symbol and under the ❄️ symbol will now flash while the beverage chiller is gearing up to switch back to normal operation.
- After 5–20 minutes, only the indicator light will illuminate under the ❄️ symbol to confirm the beverage chiller is back in its normal cooling mode.

IMPORTANT

- The beverage chiller will go through its normal automatic defrosting cycle and a manual defrosting operation is only required in most extreme cases. It is better to avoid if not necessary.
- While in the 'Defrost' mode, the beverage chiller cooling power is reduced. The automatic cycles ensure the defrosting is done in the most efficient manner, and only when required. It is not recommended to leave the beverage chiller in the manually set defrost mode for prolonged periods of time.

Loading the Beverage Chiller

- Always check that you can close the door without it hitting a bottle or can, before shutting it.
- When loading several bottles or cans at once, it will take longer for the appliance to cool the individual bottles or cans.

IMPORTANT

- Do not overload the cabinet, and only store drinks in sealed bottles or cans.
- Storing larger or different shaped bottles may affect its storage capacity. If storing larger bottles, make sure that they do not prevent the door from shutting properly. Before shutting the door, always check that you can close it without bottles falling down inside the cabinet.

Note: The controller allows you to choose a desired operating temperature of between 0°C and 10°C. Stirling do not recommend to operate the beverage chiller on settings of below 4°C for prolonged periods, as doing so could cause contents of the chiller to freeze. This could result in unnecessary strain on the cooling systems, and undue high energy consumption.

Operating the Internal Light

- The light inside the beverage chiller can be turned On and Off using the light switch found on the right-hand side internal wall of the chiller. Fig. 4

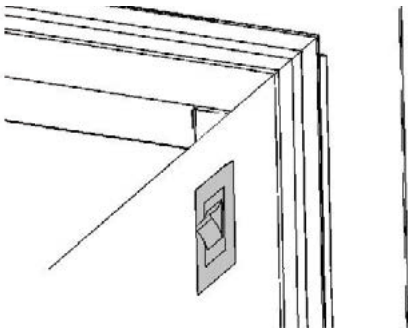

Fig. 4

FAQs & Troubleshooting

Problem	Possible Cause	Possible Solution
The beverage chiller does not operate	<ul style="list-style-type: none"> • The appliance is not plugged in. • The appliance is turned off. • The circuit breaker tripped or a blown fuse. 	<ul style="list-style-type: none"> • Plug in appliance. • Turn on power point. • Reset circuit breaker/replace fuse.
The beverage chiller is not cold enough	<ul style="list-style-type: none"> • Check the temperature control setting. • The door is opened too often, or is kept open for too long. • The beverage chiller has recently been disconnected for a period of time. The door is not closed completely. 	<ul style="list-style-type: none"> • Reduce the temperature. • Do not open door for 4 hours. • Check that the door is closed properly and for any obstructions preventing the door closing properly.
The beverage chiller turns on and off frequently	<ul style="list-style-type: none"> • The room temperature is hotter than normal. • A large amount of contents has been added to the beverage chiller. • The door is opened too often. • The door is not closed completely. • The temperature control is not set correctly. • The door gasket does not seal properly. 	<ul style="list-style-type: none"> • Increase air flow into room. • Do not open door for 4 hours to allow beverage chiller to cool to temperature. • Check that the door is closed properly and for any obstructions preventing the door closing properly. • Check temperature setting and decrease if required. • Replace gasket.
Vibrations	<ul style="list-style-type: none"> • Beverage chiller is not level. • Beverage chiller is touching the wall. • If continued vibration occurs. 	<ul style="list-style-type: none"> • Level beverage chiller. • Ensure a 5cm gap from sides and top • Turn off the beverage chiller, unplug the power plug and contact our after sales support centre for further assistance.
The door will not close properly	<ul style="list-style-type: none"> • The beverage chiller is not level. • The gasket is dirty. • The shelves are out of position. 	<ul style="list-style-type: none"> • Level beverage chiller. • Clean gasket with warm water and a soft cloth. • Re-position shelves correctly.
Moisture forms on the inside walls	<ul style="list-style-type: none"> • The door is slightly open. • The door is kept open too long, or is opened too frequently. • The door does not seal properly. 	<ul style="list-style-type: none"> • Check that the door is closed properly and for any obstructions preventing the door closing properly. • Do not open door for 4 hours to allow beverage chiller to cool to temperature. • Check if gasket is damage and replace if it is.
Moisture forms on the outside of the appliance	<ul style="list-style-type: none"> • The door is slightly open, causing cold air from inside the beverage chiller to meet warm, moist air from outside. 	<ul style="list-style-type: none"> • Check that the door is closed properly and for any obstructions preventing the door closing properly.

Other Useful Information

Cleaning and Maintenance

WARNING

Before cleaning the appliance, make sure it is switched off and disconnected from the power supply. Failure to do so can result in electric shock or injury.

- Before cleaning: take out any drinks as well as the shelves.
- Wash the inside surfaces with a solution of lukewarm water (1L) and baking soda (2 tbsp). Use a soft, clean cloth to wipe down the surfaces, then rinse with clean water and dry with a dry cloth. Do not use soap or detergent for cleaning the cabinet. DO NOT allow the control panel, cables or plug to get wet.

NOTE: Wring excess water out of the cloth when cleaning around the controls or electrical parts.

- Make sure to keep the door gasket (seal) clean to keep the unit running efficiently.
- Wash the shelves and the outside of the cabinet with a mild detergent solution. Wipe dry with a clean soft cloth.
- Dust or anything else blocking the vent may hinder the cooling efficiency of the appliance. Always keep the vent clean; vacuum it if necessary.

WARNING

Never clean the unit with an abrasive, acid, oil or solvent based cleaning agent. Never use flammable fluids or sprays for cleaning as the fumes from these substances can create a fire hazard or explosion.

When You Are on Holidays

- Leave the beverage chiller operating during holidays of less than three weeks. If you are not going to use the beverage chiller for longer periods, remove all items and unplug the power cord. Clean and dry the interior thoroughly. To prevent odours and mould growth, leave the door open slightly, blocking it open if necessary.
- To move the beverage chiller, take all items out of the appliance, securely tape down the shelves or remove them and tape the door shut. Turn the levelling leg up to the base to avoid damage.
- Protect the outside of the beverage chiller with a blanket or similar soft material and make sure the beverage chiller stays secure in the upright position during transportation.

Adjusting the Height and Leveling

- The appliance is equipped with adjustable feet, so that the height may be adjusted to level the cabinet on uneven floor surfaces.
- We recommend that two people carry out this procedure.
- The height must be adjusted prior to building the appliance into the housing unit and it should be set at such a height that the top panel of the appliance fits 5cm below the kitchen worktop.
- Tilt the appliance approximately 60° to allow access to the adjustable feet.
- Take care to ensure the cabinet is supported at all times.
- Twist the foot into a suitable position to level the cabinet. (Fig. 5)
- Repeat these steps for the other adjustable feet.

IMPORTANT: If the appliance is not level, then the door and door seal may be affected.

IMPORTANT: Do not move the appliance when the feet are adjusted high.

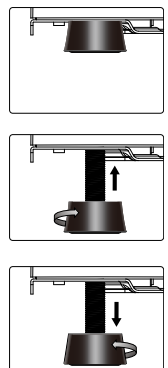

Fig. 5

Other Useful Information Cont.

Power Failure

Most power failures are corrected within a few hours and should not affect the temperature of your beverage chiller if you minimise the number of times the door is opened. If the power is going to be off for a longer period of time, take proper steps to protect the contents.

Service and Repair

Do not attempt to alter or modify this beverage chiller in any way. Do not attempt to repair or replace any part of the beverage chiller unless it is specifically recommended in this manual. All other servicing should be referred to a qualified technician. Contact the after sales support line for advice.

Spare Parts

Our after sales support centre stocks a selection of spare parts for the SOBFB118 – 118L Outdoor Beverage Chiller. To purchase a part outside of warranty, call the centre on 1300 11 4357 or email us at: support@residentiagroup.com.au

Replacing Lamps

Your Outdoor Beverage Chiller uses a long-life, energy-saving LED light tube. Should you need to replace this light, please call the centre on 1300 11 4357 for a suitable replacement part.

To change the light tube

- 1 Unplug the power plug and ensure the light switch is off.
- 2 Remove the screws on both end of the light.
- 3 Take off the lamp, pull out the wires slightly.
- 4 Gently pull out the connector at the end of the light tube.
- 5 Insert the connector into the new lamp, and fasten it.

Using the Door Lock

The Outdoor Beverage Chiller is equipped with a door lock (Fig. 6, A) and a key (+ 1 spare) to keep your drinks safe. Please place the keys in a safe location.

To operate the lock:

- 1 Insert the key to the lock when the door is closed.
- 2 Turn the key to lock/unlock the door.



Fig. 6

Specification and Technical Parameters

This product complies with AS/NZS 60335.1 and AS/NZS 60335.2.24 electrical safety, and with EN 55014-1:2006+A1:2009 A2:2011 for electromagnetic compatibility.

Responsible Disposal

- At the end of its working life, do not throw this appliance out with your household rubbish. Electrical and electronic products contain substances that can have a detrimental effect on the environment and human health if disposed of inappropriately.
- This refrigeration appliance contains flammable refrigerants and insulation blowing gases, which must be removed before disposal. Observe any local regulations regarding the disposal of electrical consumer goods and dispose of it appropriately for recycling and recovery of the refrigerant. Contact your local authorities for advice on recycling facilities in your area.
- **Danger:** Risk of child entrapment! To avoid the possibility of child entrapment, take off the door and leave the shelves in place before discarding your beverage chiller so that children cannot easily climb inside.



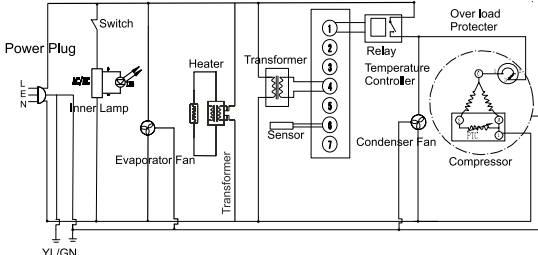

118L Outdoor Beverage Chiller



MODEL	SOBF118
CLIMATE CLASS	T
STORAGE VOLUME	118L
PROTECTION CLASS	I
VOLTAGE	220-240V/50Hz
INPUT CURRENT	1.2A
LAMPS POWER	3.3W
IP RATE:	IPX4
REFRIGERANT	R600a/55g
DIMENSIONS (HxWxD)	850x560x540mm
INSULATION BLOWING AGENT	Cyclopentane
SERIAL NO.	

Residentia Group PTY LTD Made in: China 10/2018

Barcode: 2635 0400 PLU: 62575 V1.3









Caution: risk of fire





E2447







 (AUS) 1300 11 4357

 support@residentiagroup.com.au

AFTER SALES SUPPORT

 (AUS) 1300 11 43 57

 support@residentiagroup.com.au

MODEL: SOBF118 | PRODUCT CODE: 62575 | 10/2018



118L OUTDOOR BEVERAGE CHILLER

Repair and Refurbished Goods or Parts Notice

Unfortunately, from time to time, faulty products are manufactured which need to be returned to the Supplier for repair.

Please be aware that if your product is capable of retaining user-generated data (such as files stored on a computer hard drive, telephone numbers stored on a mobile telephone, songs stored on a portable media player, games saved on a games console or files stored on a USB memory stick) during the process of repair, some or all of your stored data may be lost.

We recommend you save this data elsewhere prior to sending the product for repair.

You should also be aware that rather than repairing goods, we may replace them with refurbished goods of the same type or use refurbished parts in the repair process.

Please be assured though, refurbished parts or replacements are only used where they meet ALDI's stringent quality specifications.

If at any time you feel your repair is being handled unsatisfactorily, you may escalate your complaint. Please telephone us on 1300 11 43 57 or write to us at:

Residentia Group
118 Campbell Street
Collingwood VIC 3066
Australia

Email: support@residentiagroup.com.au

Helpline hours of operation:
Mon–Fri
9:00 AM - 5:00 PM





Please read the manual

It will help you get the best out of your product.

Still have questions?

Call After Sales Support

1300 11 4357

Or visit
www.residentiagroup.com.au

Warranty returns

Should you for any reason need to return this product for a warranty claim, make sure to include all accessories with the product.

Product does not work?

If you encounter problems with this product, or if it fails to perform to your expectations, make sure to contact our After Sales Support Centre on 1300 11 4357.

For an electronic copy of this manual, go to www.stirlingappliances.com.au and download a copy.

This page
is intentionally
left blank