

User Manual

Please read this user manual throughout before using

Ver:B

Preface

All internal technologies of this product are protected, including device, software and trademark. Reproduction in whole or in part without written permission is prohibited.

All brands and trademarks of SWIT Electronics Co., Ltd. are protected and other relative trademarks in this user manual are the property of their respective owners.

Due to constant effort of product development, SWIT reserves the right to make changes and improvements to the product described in this manual without prior notice.

The warranty period of this product is one years, and does not cover the following:

- (1) Physical damage to the products
- (2) Any damage or breakdown caused by use, maintenance, or storage not according to the user manual' s introductions.
- (3) The attenuation of signal quality resulting from being used in any special environments.
- (4) Any damage caused by not powering the product by package supplied power adaptor.
- (5) Any damage or breakdown not caused by the product' s design, workmanship, manufacturing, quality, or unauthorized repairs or parts replacement or other operations.

For any suggestions and requirements on this product, please contact us through

SWIT Electronics Co., Ltd.

Tel: +86-25-85805753

Fax: +86-25-85805296

Email: contact@swit.cc

<http://www.swit.cc>

Safety Precautions

Please follow the safety precautions before using. The following conditions are not covered by warranty.

1. Unauthorized repairs or other Unauthorized operations.
2. Inappropriate placement including but not limited to lighting, fire, exposure to rain, water or gas.
3. Using the wrong power supply.

Warning

- Do not get any liquid inside the products
- Do not block the ventilation openings or put substances inside, in order to avoid short circuit, fire or electric shock.
- Do not place the product in the rain or moisture to avoid electric shock or fire.

Danger

- Switch the power off before connecting other devices.
- Power socket: Make sure the power socket under the voltage range of the product to avoid short circuit, electric shock and fire.
- Power cable: Make sure the power cable is not pressed or tightened by any items or weights.
- Power Load: Do not exceed the load on the wall outlet, extension cable or other porous receptacle to avoid fire or electric shock.
- Lightning: Disconnect the power cable if it is lightning or not using in a long period of time.

Working Environment

- Please don't lay the product on any unstable place to avoid fallen damage.
- Please don't use the product in a place overheating, undercooling or with lots of moisture, or near by strong magnetic devices.
- Please don't lay the product on metal shelf, in order to ensure the effective wireless transmission.

Contents

Preface	2
Safety Precautions	3
Packing list	4
1. Product Introduction	5
2. Features	5
3. Appearance Instruction	6
Transmitter CREW TX	6
Receiver CREW RX	7
Transmitter CREW-V TX	8
Receiver CREW-V RX	9
Receiver CREW MAX	10
4. LCD Display menu	11
Transmitter	11
Receiver	12
5. Menu Interface	13
6. Pairing	14
7. Connection	16
8. System Upgrade	17
9. UVC	18
10. The way to get the best effective of Wireless Transmission	21
11. Trouble shooting	22
12. Specification	23

Packing list

This product includes the following accessories (individually packaged) :

1. Transmitter
2. Receiver
3. Four antennas
4. Four high-gain antennas
5. Eight antenna protective covers
6. One OTG adapter
7. Two TYPE-C to TYPE-C data cables
8. Two D-TAP to LEMO cables
9. Two 1/4-inch quick-release adapters

Note: The quantity is related to the configuration and shall be subject to the actual quantity.

1. Product Introduction

CREW includes transmitter and receiver, adopts the latest encrypted transmission technology,- Supports SDI and HDMI® wirelessly transmitted in 1200 meters scale (line-of-Sight), With the panel antenna receiver CREW MAX, the effective transmission distance can be extended to 3 kilometers. 2 channels SD/HDMI® digital video transmission, auto pairing and OLED display. CREW is equipped with DC power connector, compact size, portable, and the receiving signal is very stable.

2. Features

◎ **3G/HD/SD-SDI and HDMI® transmission**

Support up to 1080p 50/60Hz SDI & HDMI® wireless transmission.

◎ **1.2 / 3-kilometer Transmission Distance**

In open outdoor area, the effective transmission distance is approx. 1200 meters (line of sight). With the panel antenna receiver CREW MAX, the effective transmission distance can be extended to 3 kilometers.

◎ **Support for UVC Transmission**

On the receiving end, only one USB cable is needed to output 1080P60 video to a computer.

◎ **Pairing Modes**

Support auto pairing connection and manual switching of frequency points. Support one transmitter to multi-receiver mode.

◎ **Seamless Frequency Hopping**

In AUTO mode, it can automatically hop frequencies to achieve uninterrupted picture transmission.

◎ **LCD Display**

Displays the current transmission signal format, wireless channels, signal strength and other working statuses and parameters.

◎ **High-Quality Image Mode**

Support 1 transmitter to unlimited receivers high quality Image transmission

◎ **Encryption**

Support AES 128-bit encryption to protect the transmission.

◎ **Supports SDI Metadata Passthrough**

When used with mainstream cameras such as ARRI, the receiver can transmit timecode, recording triggers and other information to the monitoring device via SDI.

◎ **All-Metal Shell**

The transmitter adopt metal shell which is durable and solid.

◎ **All hardware design**

The wireless system is hardware and plug-and-play designed, without installing software, easy to set up.

Remark:

1. The transmission distance may be different, and depend on surroundings, radio wave conditions, buildings, etc., the 1200/3000 meters transmission distance may be not guaranteed.
2. Signal reception may be affected by the position, height and angle of devices. If reception video is not stable, please physically adjust placement for the optimized signal.
3. Set the antennas straight up and set receiver higher to enhance the transmission efficiency.

3. Appearance Instruction

■ Transmitter CREW TX

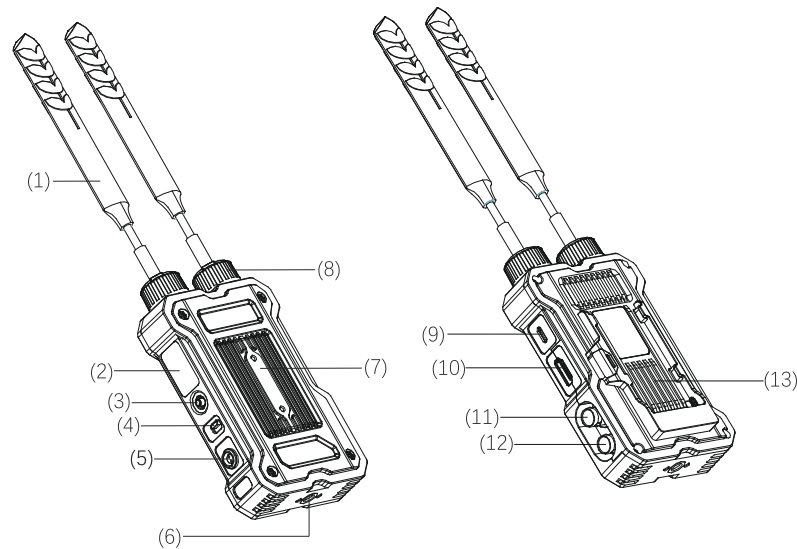



Figure 1

- (1) **Antenna**
- (2) **LCD Display Screen:** 0.96-inch LCD.
- (3) **Five-direction switch:** Five-direction adjustment button (adjust the display menu to switch and confirm in five directions: up, down, left, right, and vertical)
- (4) **ON/OFF:** Power switch
- (5) **DC in:** It supports a wide DC voltage input ranging from 7V to 17V. LEMO 0B 302 series connectors are adopted. The pin definitions are as follows:

Pin Outputs of the 2-pin Power Connector	
Pin	Description
1	Negative power supply
2	Positive power supply



Note: Pin 1 is closest to the red dot on the connector.

- (6) **Installation thread:** 1/4" -20 thread. Use the package supplied articulating arm trestle to install the device to the camera.
- (7) **Quick-release part mounting position:** Mounting position for the 1/4 quick-release adapter.
- (8) **Antenna Protective Cover:** Installation diagram of the antenna protective cover.
- (9) **USB:** TYPE-C interface, system upgrade interface.
Supports power supply at 9V/2A. The transmitter can be powered by an adapter, a battery or other devices via a TYPE-C data cable.
- (10) **HDMI® in:** HDMI® input (HDMI®-A type connector)
- (11) **SDI in:** SDI input (BNC connector)
- (12) **SDI LOOP:** SDI Loop out (BNC connector)
- (13) **Battery plate:** Type F plate, used for battery power supply. It is recommended to choose SWIT batteries S-8972, S-8970, S-8770 and S-8975, which are compatible with Sony's L-series NP-F770/970.

■ **Receiver CREW RX**

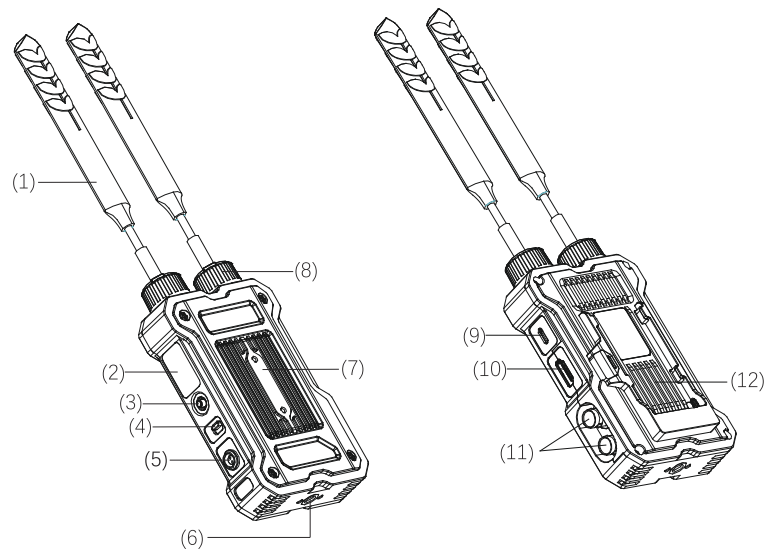
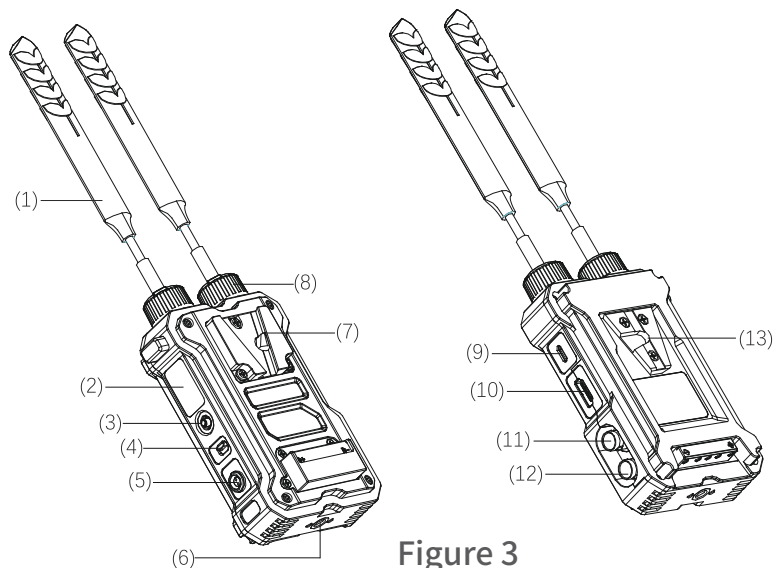

Figure 2

- (1) **Antenna**
- (2) **LCD Display Screen:** 0.96-inch LCD.
- (3) **Five-direction switch:** Five-direction adjustment button (adjust the display menu to switch and confirm in five directions: up, down, left, right, and vertical)
- (4) **ON/OFF:** Power switch
- (5) **DC in:** It supports a wide DC voltage input ranging from 7V to 17V. LEMO 0B 302 series connectors are used. For the pin definitions, please refer to the transmitter interface description.

- (6) **Installation thread:** 1/4" -20 thread. Use the package supplied articulating arm trestle to install the device to the camera.
- (7) **Quick-release part mounting position:** Mounting position for the 1/4 quick-release adapter.
- (8) **Antenna Protective Cover:** Installation diagram of the antenna protective cover.
- (9) **USB:** TYPE-C interface, system upgrade interface.
Supports for UVC Transmission.
Supports power supply at 5V/2A. The receiver can be powered by an adapter, a battery or other devices via a TYPE-C data cable.
- (10) **HDMI® OUT:** HDMI® output (HDMI®-A type connector)
- (11) **SDI out:** SDI output (BNC connector)
- (12) **Battery plate:** Type F plate, used for battery power supply. It is recommended to choose SWIT batteries S-8972, S-8970, S-8770 and S-8975, which are compatible with Sony's L-series NP-F770/970.

■ **Transmitter CREW-V TX**



- (1) **Antenna**
- (2) **LCD Display Screen:** 0.96-inch LCD.
- (3) **Five-direction switch:** Five-direction adjustment button. (adjust the display menu to switch and confirm in five directions up, down, left, right, and vertical)
- (4) **ON/OFF:** Power switch
- (5) **DC in:** It supports a wide DC voltage input ranging from 7V to 17V. LEMO 0B 302 series connectors are adopted. The pin definitions are as follows:

Pin Outputs of the 2-pin Power Connector	
Pin	Description
1	Negative power supply
2	Positive power supply



Note: Pin 1 is closest to the red dot on the connector.

- (6) **Installation thread:** 1/4" -20 thread. Use the package supplied articulating arm trestle to install the device to the camera.
- (7) **Battery plate:** V-mount plate, used for battery power supply. It is strictly prohibited to use high-voltage V-mount batteries with a voltage exceeding 18V for power supply.
- (8) **Antenna Protective Cover:** Installation diagram of the antenna protective cover.
- (9) **USB:** TYPE-C interface, system upgrade interface.
Supports power supply at 9V/2A.
The transmitter can be powered by an adapter, a battery or other devices via a TYPE-C data cable.
- (10) **HDMI® in:** HDMI® input (HDMI®-A type connector)
- (11) **SDI in:** SDI input (BNC connector)
- (12) **SDI LOOP:** SDI Loop out (BNC connector)
- (13) **Battery latch:** V mount latch, installed on the corresponding video camera. The transmitter and the video camera can be powered simultaneously by the V mount battery installed on the battery plate.

■ **Receiver CREW-V RX**

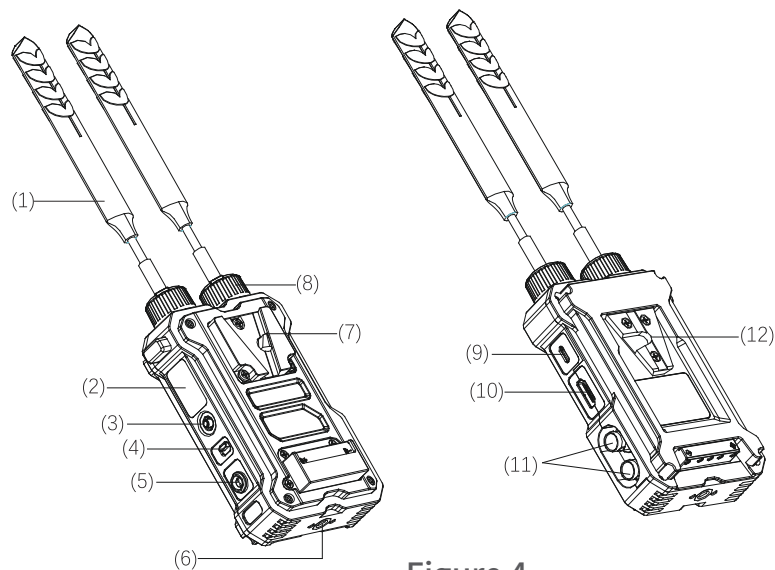

Figure 4

- (1) **Antenna**
- (2) **LCD Display Screen:** 0.96-inch LCD.
- (3) **Five-direction switch:** Five-direction adjustment button. (adjust the display menu to switch and confirm in five directions up, down, left, right, and vertical)
- (4) **ON/OFF:** Power switch
- (5) **DC in:** It supports a wide DC voltage input ranging from 7V to 17V. LEMO 0B 302 series connectors are used. For the pin definitions, please refer to the transmitter interface description.
- (6) **Installation thread:** 1/4" -20 thread. Use the package supplied articulating arm trestle to install the device to the camera.

- (7) **Battery plate:** V-mount plate, used for battery power supply. It is strictly prohibited to use high-voltage V-mount batteries with a voltage exceeding 18V for power supply.
- (8) **Antenna Protective Cover:** Installation diagram of the antenna protective cover.
- (9) **USB:** TYPE-C interface, system upgrade interface.
Supports for UVC Transmission.
Supports power supply at 5V/2A. The receiver can be powered by an adapter, a battery or other devices via a TYPE-C data cable.
- (10) **HDMI®OUT:** HDMI® output (HDMI®-A type connector)
- (11) **SDI out:** SDI output (BNC connector)
- (12) **Battery latch:** V mount latch, installed on the corresponding video camera. The transmitter and the video camera can be powered simultaneously by the V mount battery installed on the battery plate.

■ **Receiver CREW MAX**

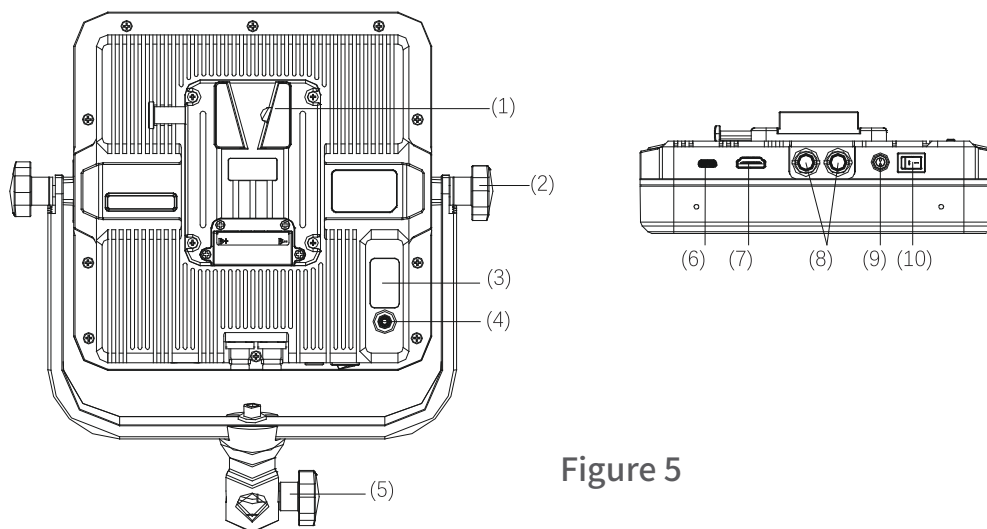

Figure 5

- (1) **Battery plate:** V-mount plate, used for battery power supply. It is strictly prohibited to use high-voltage V-mount batteries with a voltage exceeding 18V for power supply.
- (2) **Adjustable position fastening thumb screw**
- (3) **LCD Display Screen:** 0.96-inch LCD.
- (4) **Five-direction switch:** Five-direction adjustment button. (adjust the display menu to switch and confirm in five directions up, down, left, right, and vertical)
- (5) **Bottom bracket**
- (6) **USB:** TYPE-C interface, system upgrade interface.
Supports for UVC Transmission.
Supports power supply at 5V/2A. The receiver can be powered by an adapter, a battery or other devices via a TYPE-C data cable.

- (7) **HDMI®OUT:** HDMI® output (HDMI®-A type connector)
- (8) **SDI out:** SDI output (BNC connector)
- (9) **DC in:** It supports a wide DC voltage input ranging from 7V to 17V. LEMO 0B 302 series connectors are used. For the pin definitions, please refer to the transmitter interface description.
- (10) **ON/OFF:** Power switch

4.LCD Display menu

■ Transmitter

(1) Signal Format

It displays the recognizable video signal format input by the transmitter.
 When there is no recognizable video signal input, it will display "no signal".
 When the frame rate of the input video signal format is 59.94, 29.97 and 23.98, the format frame rate will be displayed as 59, 29 and 23 respectively.

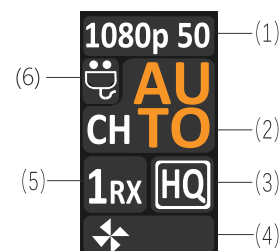

Figure 6

(2) Current Channel

It displays the current working channel between the transmitter and the receiver. The channel parameters can be changed under the channel menu.



When the channel is set to auto, this icon will be displayed on the main interface. At this time, the system will automatically hop frequencies to select an appropriate frequency point.



When the channel is set to manual, the main interface will display the currently used channel number.

(3) High Quality Mode

It displays the current working quality mode between the transmitter and the receiver. The working mode can be adjusted under the mode menu.



When the quality mode is set to high quality, this icon will be displayed on the main interface.



When the quality mode is set to auto, this icon will be displayed on the main interface.

(4) Fan

It displays the working status of the fan. The working mode of the fan can be adjusted under the fan menu.



When the working status of the fan is set to auto, this icon will be displayed on the main interface. At this time, the fan will automatically adjust its rotational speed according to the internal temperature of the transmitter.



When the working status of the fan is set to off, this icon will be displayed on the main interface. At this time, the fan stops working.

(5) Number of Receivers

It displays the number of receivers that are currently successfully connected to this transmitter. When there is no receiver connected, it will display "0RX".

(6) Power Supply Indicator

Displays the current power supply method—either battery power or DC IN



When powered via the DC IN connector, this icon will appear on the main interface.



When powered via the battery mount, this icon will appear on the main interface. The battery level is indicated by four bars. When the battery level is low, an empty red warning frame will be displayed.

■ Receiver

(1) Signal Format

It displays the recognizable video signal format received by the receiver.

When no recognizable video signal is received, it will display "no signal".

When the frame rate of the received video signal format is 59.94, 29.97 and 23.98, the format frame rate will be displayed as 59, 29 and 23 respectively.

(2) Current Channel

It displays the working channel between the current transmitter and the receiver.

This channel parameter can only be set through the transmitter menu.

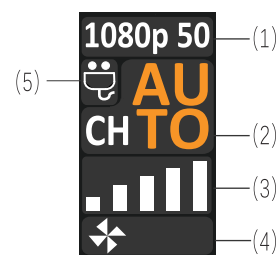

Figure 7



When the transmitter channel is set to auto, this icon will be displayed on the main interface.



When the transmitter signal is set to manual, the main interface will display the currently used channel number.

(3) Signal Strength

It displays the strength of the signal connection between the current receiver and the transmitter.

When the receiver fails to connect successfully with the transmitter, it will display "unlink".

(4) Fan

It displays the working status of the fan. The working mode of the fan can be adjusted under the fan menu.



When the working status of the fan is set to auto, this icon will be displayed on the main interface. At this time, the fan will automatically adjust its rotational speed according to the internal temperature of the receiver.



When the working status of the fan is set to off, this icon will be displayed on the main interface. At this time, the fan stops working.

(5) Power Supply Indicator

Displays the current power supply method—either battery power or DC IN



When powered via the DC IN connector, this icon will appear on the main interface.



When powered via the battery mount, this icon will appear on the main interface. The battery level is indicated by four bars. When the battery level is low, an empty red warning frame will be displayed.

Note: The receiver CREW MAX does not show a fan status icon.

5. Menu Interface

(1) Entering the Menu

On the transmitter, you can switch to the menu interfaces shown in Figure 8, Figure 9, Figure 11, Figure 12 and Figure 13 by toggling the red five-way key left and right.

On the receiver, you can switch to the menu interfaces shown in Figure 10, Figure 11, Figure 12 and Figure 13 by toggling the red five-way key left and right.

On the receiver CREW MAX, you can switch to the menu interfaces shown in Figure 10, Figure 12 and Figure 13 by toggling the red five-way key left and right.



Figure 8



Figure 9



Figure 10



Figure 11



Figure 12



Figure 13

(2) Menu Functions

CHANNEL Channel, as shown in Figure 8.

It is for selecting the communication channel between the transmitter and the receiver. Users can adjust the desired channel between AUTO and 00 - 21.

MODE Mode

As shown in Figure 9, the transmitter allows users to select the working quality mode between the transmitter and receiver through the mode menu. Users can switch between HQ (High Quality) mode and AUTO mode.

As shown in Figure 10, the receiver allows users to adjust the latency of the received image through the mode menu. Users can choose between Stable mode and Low Latency mode. In Stable mode, the system prioritizes interference resistance but with increased video latency.

FAN Fan, as shown in Figure 11.

It is for selecting the working status of the fans of the transmitter and the receiver respectively. Users can adjust between AUTO and OFF.

PAIR Pair, as shown in Figure 12.

The transmitter and the receiver can enter the pairing state by clicking "START" respectively. Refer to "6. Pairing Methods" below for the pairing method.

CREW Model and Versions, as shown in Figure 13.

It is used to view the software version information of the transmitter and the receiver, and the system can be upgraded by clicking "START". Refer to "8. System Upgrade" below for the upgrade method.

Tips: The channel and image quality mode menus can only be selected and adjusted on the transmitter. When the transmitter and the receiver are connected, the receiver will automatically match and display the parameters adjusted by the transmitter on the main interface.

(3) Adjustment of Functional Parameters

Toggle the red Five-direction switch up and down to adjust the parameter values under the current menu function.

After adjusting the parameters in the channel and mode menus to the desired values, the parameters will blink. At this time, press the Five-direction switch vertically downward to confirm.

After confirming the parameters in the mode menu, a prompt "Please Reboot" will be displayed, as shown in Figure 14. At this time, it is necessary to restart the transmitter.



Figure 14

After adjusting the parameters in the fan menu to the desired values, they will take effect without the need for confirmation.

Note: When adjusting the parameters in the channel and mode menus, the parameter settings will only take effect after pressing the Five-direction switch vertically downward to confirm. Otherwise, the parameter settings will be invalid, and the menu will automatically switch back to the main interface after a period of time.

6. Pairing

- (1) Turn on the power of the transmitter and receiver, and wait for the interface to jump to the main interface.
- (2) Toggle the Five-direction switch of the transmitter to the right to the "PAIR" pairing menu shown in Figure 12. Then, toggle the Five-direction switch up and down to select the "START" option, and press the Five-direction switch vertically downward to confirm, thus entering the pairing page.

- (3) At this time, the transmitter will prompt "Ready to pair?", as shown in Figure 15. Press the Five-direction switch vertically downward to confirm, and the transmitter will pop up the waiting-for-pairing page shown in Figure 16.
- (4) The receiver also switches to the "PAIR" pairing menu through the Five-direction switch. After entering the pairing page, press the Five-direction switch vertically downward to confirm, and the receiver will pop up the page shown in Figure 17. When using one transmitter with multiple receivers, it is necessary to make each receiver enter the pairing page one by one and then press the Five-direction switch to confirm.



Figure 15



Figure 16



Figure 17

- (5) After waiting for a while, the transmitter will pop up the page shown in Figure 18, which displays the number of receivers successfully paired with the transmitter. The receiver will pop up the pairing-successful page shown in Figure 19, indicating that the pairing is successful. At this time, the transmitter can press the Five-direction switch vertically downward to confirm and then exit the pairing page and return to the main interface. The receiver can also press the Five-direction switch vertically downward to confirm and exit the pairing page, or wait for a while until the pairing page automatically exits and returns to the main interface.



Figure 18



Figure 19



Figure 20

- (6) If the pairing fails, the transmitter will remain on the waiting-for-pairing page shown in Figure 16. The receiver will prompt the pairing-failed page shown in Figure 20.

Note:

1. During the pairing process, if no receiver is successfully paired with the transmitter, the transmitter will remain in the waiting-for-pairing state shown in Figure 16. Press the Five-direction switch vertically downward to confirm in order to exit the pairing menu and return to the main interface.
2. The system supports a maximum of one transmitter paired with four receivers simultaneously, that is, one transmitter can be used with four receivers at the same time.
3. The paired receivers and the transmitter will automatically connect after being turned on, and there is no need for pairing again.

7. Connection

- (1) Connect the SDI IN/HDMI® IN interface of the transmitter to the SDI OUT/HDMI® OUT of the video camera or video output device. Connect the SDI LOOP interface of the transmitter to the SDI IN of the monitor or switcher.
- (2) Connect the SDI OUT interface of the receiver to the SDI IN of the monitor or switcher. When multiple receivers are used simultaneously, connect the SDI OUT interface of each receiver to the SDI IN of the monitor or switcher.
- (3) Switch on both transmitter and receiver, LCD screen show "SWIT" then jump into initial interface, Wait for a while after turning on the device. If the transmitting end and the receiving end are successfully connected and there is recognizable signal input or output, the main interface will display the prompt patterns as shown in Figure 6 and Figure 7. If there is recognizable signal input at the transmitting end but the connection fails to be established, the signal format on the main interface shown in Figure 6 will still be displayed.

Tips:

1. When connecting the power of the transmitter and receiver, turn the power switches on the products to "ON" respectively.
2. The transmitter supports the SDI video input interface and the HDMI® video input interface, and the system will automatically detect the video interface with input. If there is video input on both the HDMI® and SDI interfaces, the system will give priority to the signal from the SDI interface as the signal source.
3. When multiple sets of receivers are used simultaneously in the same environment, ensure that all the sets of wireless devices in use have recognizable signal input.

8. System Upgrade

- (1) Download the latest firmware upgrade package to the root directory of the USB flash drive, and directly unzip the compressed package into the root directory folder.
- (2) Connect the USB flash drive to the TYPE-C interface of the transmitter or receiver through an OTG adapter.
- (3) Toggle the Five-direction switch of the transmitter or receiver to the right to the "VER" version information menu shown in Figure 13. Then, press the Five-direction switch vertically downward to confirm and enter the version upgrade page.
- (4) At this time, the transmitter or receiver will prompt "Ready to update?", as shown in Figure 21. Press the Five-direction switch vertically downward to confirm, and the transmitter or receiver will pop up the upgrade progress bar shown in Figure 22.
- (5) Wait for a while until the progress bar is filled. After the upgrade is successful, it will prompt "Please restart the device" as shown in Figure 23. At this time, restart the transmitter or receiver to complete the upgrade.
- (6) If the upgrade of the transmitter or receiver fails, it will pop up the error prompt shown in Figure 24 and display the error code. The meanings of the error codes are as follows:
 - ERROR 01: It indicates that there is an error in the files on the USB flash drive or there are no files;
 - ERROR 02: It indicates that the USB flash drive has not been recognized.
 - ERROR 03: It indicates that there is an error in the FPGA (.bit) file.



Figure 21



Figure 22



Figure 23



Figure 24

Tip: The firmware upgrade package needs to be used to upgrade both the transmitter and the receiver. After the upgrade is completed, the transmitter and the receiver need to be paired again for use.

9.UVC

- (1) Refer to the steps in "7. Connection" to establish a connection between the transmitter and the receiver, and connect a recognizable video signal to the transmitter.
- (2) Use a TYPE-C to TYPE-C or TYPE-C to TYPE-A connection cable to connect the receiver and the computer.
- (3) As shown in Figure 25, open the Computer Device Manager and check whether there is a UVC Camera device under the Cameras category to confirm that the computer has recognized the UVC input of the receiver.

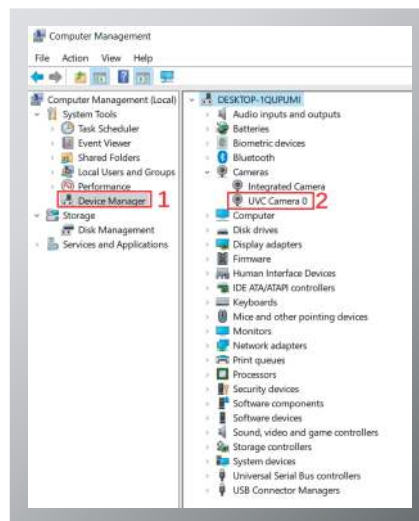

Figure 25

- (4) After confirming that the computer has recognized the input from the receiver, open the OBS software, as shown in Figure 26. Click the "+" button on the tab for adding sources at the bottom, as shown in the red box in Figure 26.

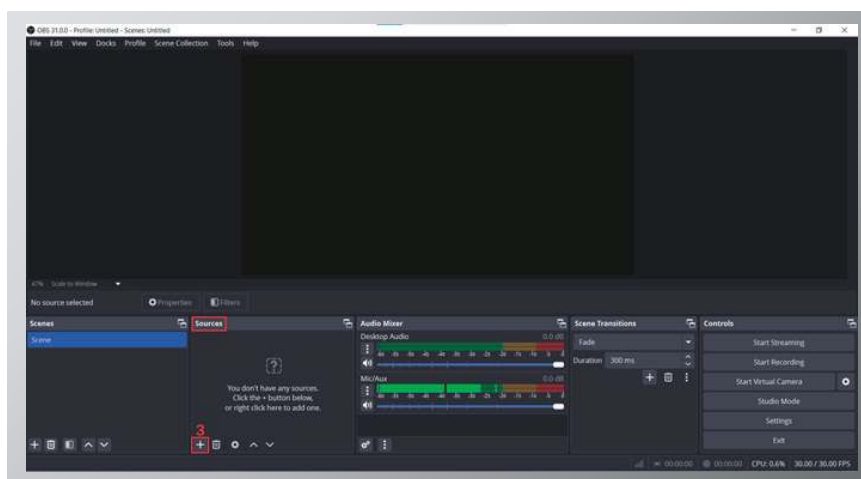

Figure 26

(5) A menu as shown in Figure 27 will pop up. Click on "Video Capture Device".

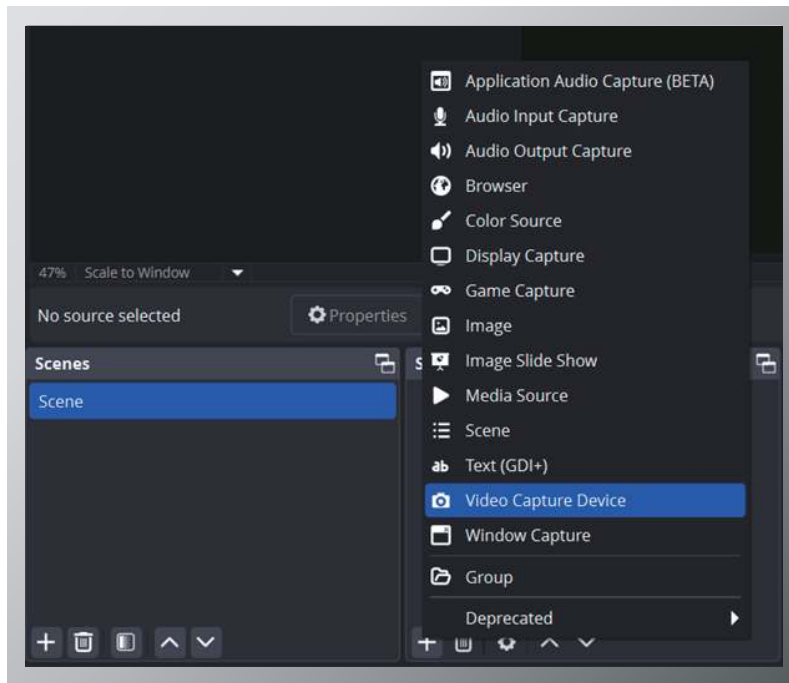

Figure 27

(6) The "Create Source" menu shown in Figure 28 will pop up. Confirm the options as illustrated, and finally click "OK".

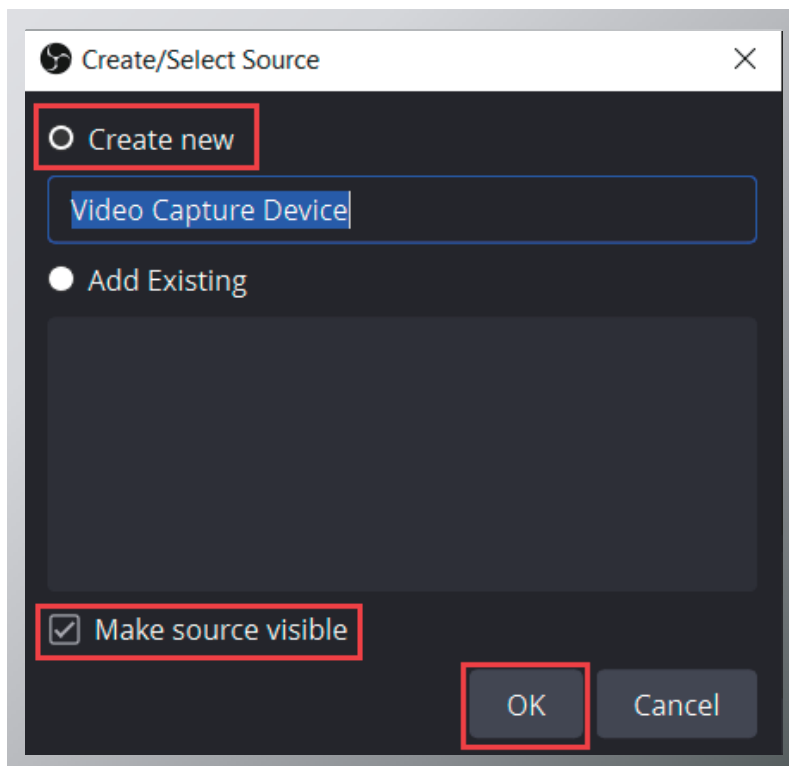

Figure 28

(7) The video capture device menu shown in Figure 29 will pop up. Select the device as "UVC Camera 0" through the drop-down option of "Device"; select "Device Default" or "Custom" through the drop-down option of "Resolution/FPS Type". After selecting "Device Default", the video image output by the receiver will be automatically displayed. After selecting "Custom", you need to set the video display parameters as shown in Figure 30 according to your needs. The video image output by the receiver will be displayed only after the settings are completed. After the settings are completed, click "OK" in the lower right corner to display the image output by the receiver normally.

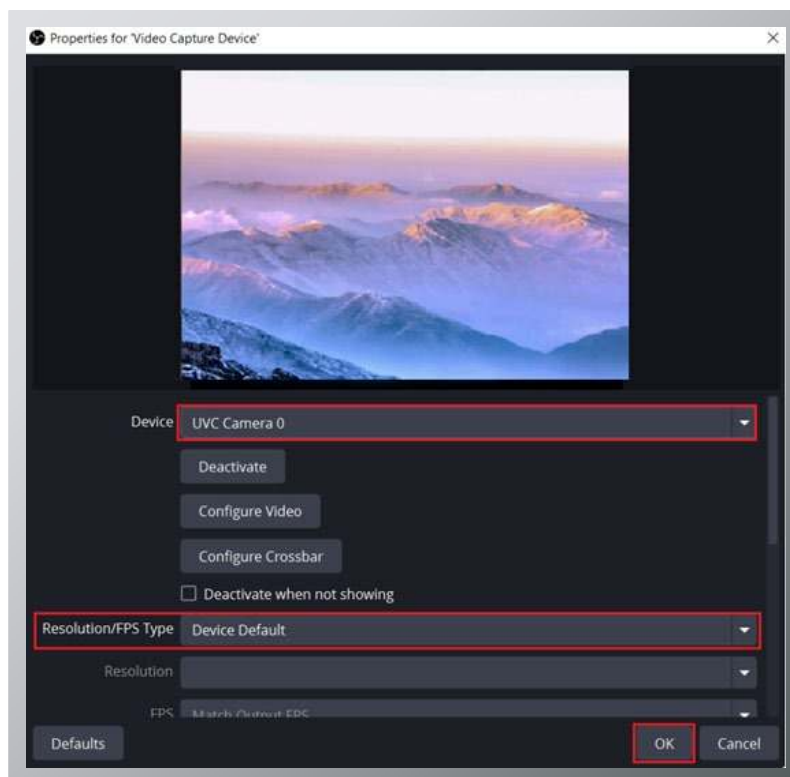

Figure 29

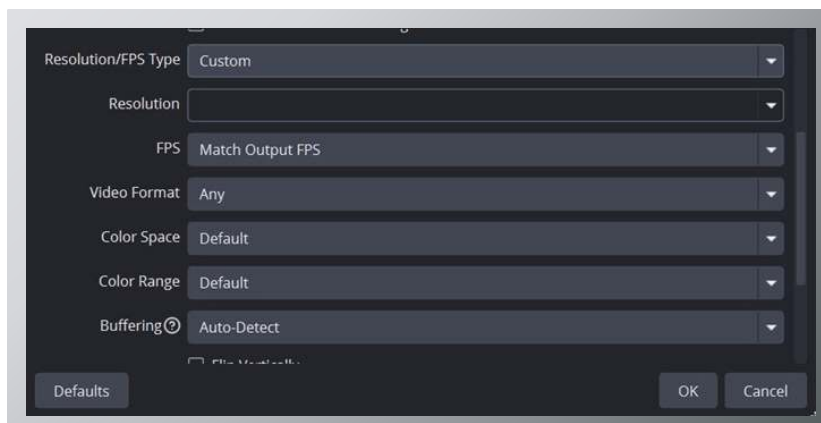
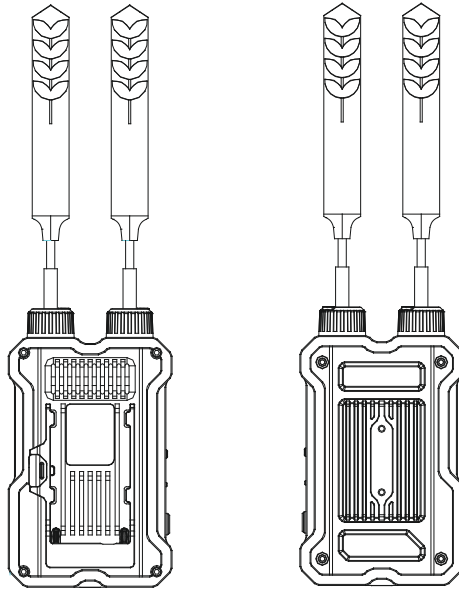

Figure 30

10. The way to get the best effective of Wireless Transmission

(1) Set the antenna on both transmitter and receiver vertically straight up. Set the receiver faces the transmitter to extend the transmission distance and stabilize the transmission quality.



(2) Set the receiver as high as possible to avoid interference.

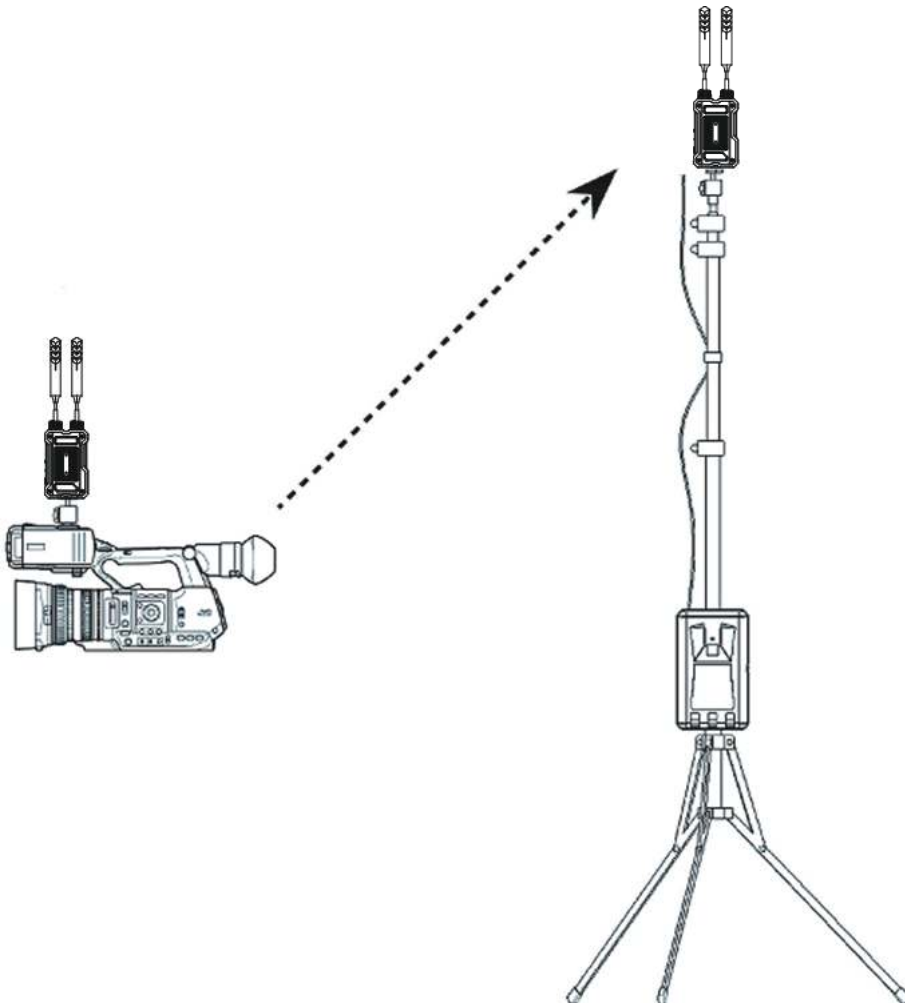

(3) Avoid walls, trees and water to reduce signal attenuation.

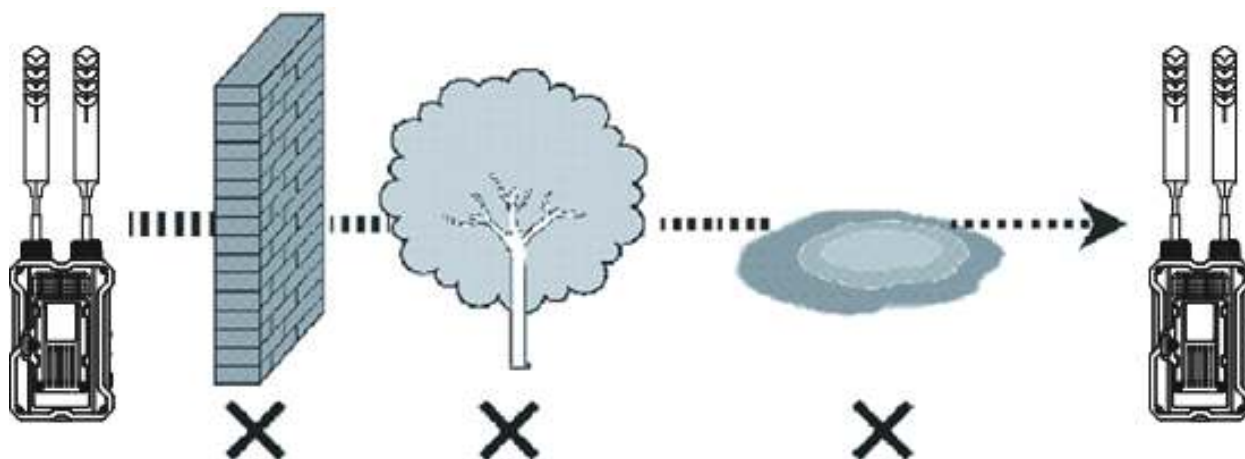

11. Trouble shooting

If the receiver failed to output video correctly, the possible causes are as below; please find the solution from following chart:

The receiving video	Possible causesvideo	Solution
No display	The transmitter receiver is not powered on	Check power connection and switch on the transmitter and receiver
	The antennas are not installed properly and screwed tightly	Install the antennas properly and screw tightly of both transmitter and receiver
	Bad connection of video cable	Check video cable connection of both transmitter and receiver
	Video format is not supported	Change the output video format of the camera
Poor Video quality	Bad connection with video cable	Reconnect reliably
	The wireless transmission is disturbed by environment	Wait for 1 minute or reboot the transmitter and receiver
	The transmission distance is out of effective range	Close the transmitter to the receiver

12. Specification

Model	Transmitter	Receiver
Input	SDI×1、HDMI®×1	/
Output	SDI×1	HDMI®×1、SDI×2、UVC×1
Video format	1080I (60/59.94/50) /1080PsF (30/29.97/25/24/23.98) /720P (60/59.94/50)/1080P (60/59.94/50/30/29.97/25/24/23.98)	
modulation mode	OFDM Support 16QAM, 64QAM, QPSK, BPSK modulation mode	
transmission distance	1.2KM (Line of sight) 3KM (Line of sight, requires CREW MAX panel antenna receiver)	
Power consumption	≤16W	≤6W
Human-Machine Interaction	0.96-inch LCD Monitor, Five-direction adjustment button	
Input voltage	DC/Battery : 7-17V USB:9V/2A	DC/Battery : 7-17V USB:5V/2A
Working environment	Temperature :-10°C~+40°C	
Dimension(without antenna and plate)	CREW TX:130×80×36.7mm CREW-V TX:130×85.9×44.8mm	CREW RX:130×80×36.7mm CREW-V RX:130×85.9×44.8mm CREW MAX:190×190×50mm (without battery plate and bracket)
Net weight (without antenna)	CREW TX:333g CREW-V TX:399g	CREW RX:334g CREW-V RX:397g CREW MAX:1.51kg