



RVK 150E2-L SILEO 1PH/230V

Item no. 30341

Version: 50 Hz

Document type: **Product card**
 Document date: **2019-06-24**
 Generated by: **Systemair Online Catalogue**



Description

- Speed-controllable
- Integral thermal contacts acc. EN 60335-2-80
- Can be installed in any position
- Inclusive mounting bracket
- Maintenance-free and reliable

The RVK sileo series is designed for installation in ducts. The casing is manufactured from PP fibreglass reinforced plastic which gives the fan a less leakage casing. Duct connected wet room applications of the fan are possible due to the air tight casing and the IP 44 rated terminal box. We recommend a period of continued ventilation with dry air for wet room applications. The fans have high effective backward-curved blades (* BAT with special geometry) and external rotor motors. The FK mounting clamp facilitates easy installation and removal, and prevents the transfer of vibration to the duct. The fans can be speed-controlled via a stepless thyristor or a 5-step transformer. To protect the motor from overheating the models have integrated thermal contacts with manual reset.



Technical parameters

Nominal data		
Voltage	230	V
Frequency	50	Hz
Phase	1	~
Input power (P1)	109	W
Current	0,48	A
Max. airflow	0,2	m³/s
R.p.m.	2527	r.p.m.
Capacitor	3	µF
Weight	3,2	kg
Temperature data		
Max. temperature of transported air	70	°C
Max. temperature of transported air when speed-controlled	70	°C
Sound data		
Sound pressure level at 3 m	44,8	dB(A)

Get In Touch

Call: [0845 6880112](tel:08456880112)
 Email: info@adremit.co.uk

Our Address

Puravent, Adremit Limited, Unit 5a, Commercial Yard,
 Settle, North Yorkshire, BD24 9RH



Protection / Classification

Insulation class	F
Enclosure class, motor	IP44

ErP

Energy class, basic unit	E
Energy class, basic unit option	C
ErP ready	ErP 2016/ErP 2018

Energy class label

Energy class, basic unit

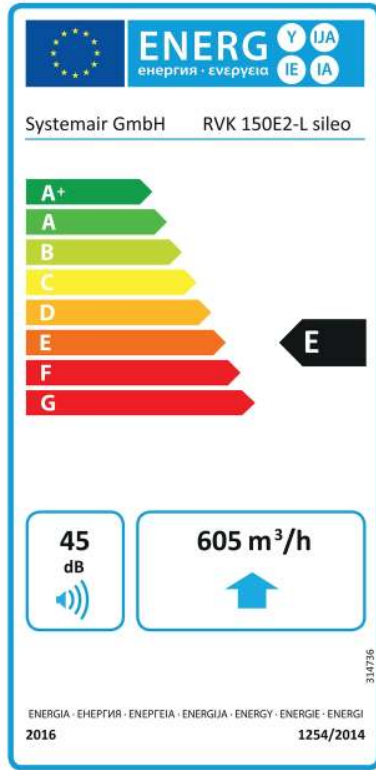

Name: **RVK 150E2-L SILEO 1PH/230V** | Item no.: **30341** | Version: **50 Hz**

Document type: **Product card** | Document date: **2019-06-24** | Generated by: **Online catalogue**

2 / 6

Get In Touch



Call: [0845 6880112](tel:08456880112)



Email: info@adremit.co.uk

Our Address

Puravent, Adremit Limited, Unit 5a, Commercial Yard,
Settle, North Yorkshire, BD24 9RH

Energy class, unit with local demand control

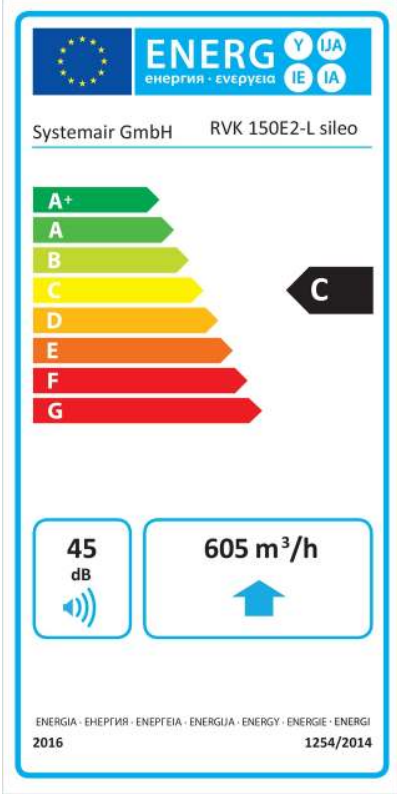

EPS diagrams

Diagrams

Diagrams

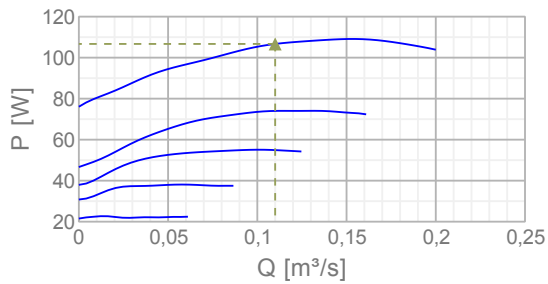
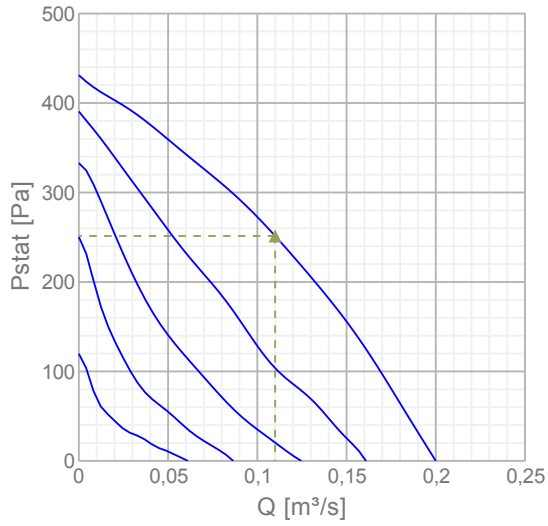

Name: **RVK 150E2-L SILEO 1PH/230V** | Item no.: **30341** | Version: **50 Hz**

Document type: **Product card** | Document date: **2019-06-24** | Generated by: **Online catalogue**

Get In Touch

Call: [0845 6880112](tel:08456880112)
Email: info@adremit.co.uk

Our Address

Puravent, Adremit Limited, Unit 5a, Commercial Yard,
Settle, North Yorkshire, BD24 9RH

Max efficiency

Hydraulic data	
▲ Working air flow	0,11 m ³ /s
▲ Working static pressure	251 Pa
▲ Power	107 W
Speed	2552 r.p.m.
Current	0,464 A
SFP	0,97 W/(l/s)
Voltage	230 V

Sound power level		63	125	250	500	1k	2k	4k	8k	Tot
Inlet	dB(A)	44	60	62	63	63	59	55	46	69
Outlet	dB(A)	47	60	63	61	63	58	52	44	68
Surrounding	dB(A)	12	20	30	46	49	46	37	25	52

Dimensions

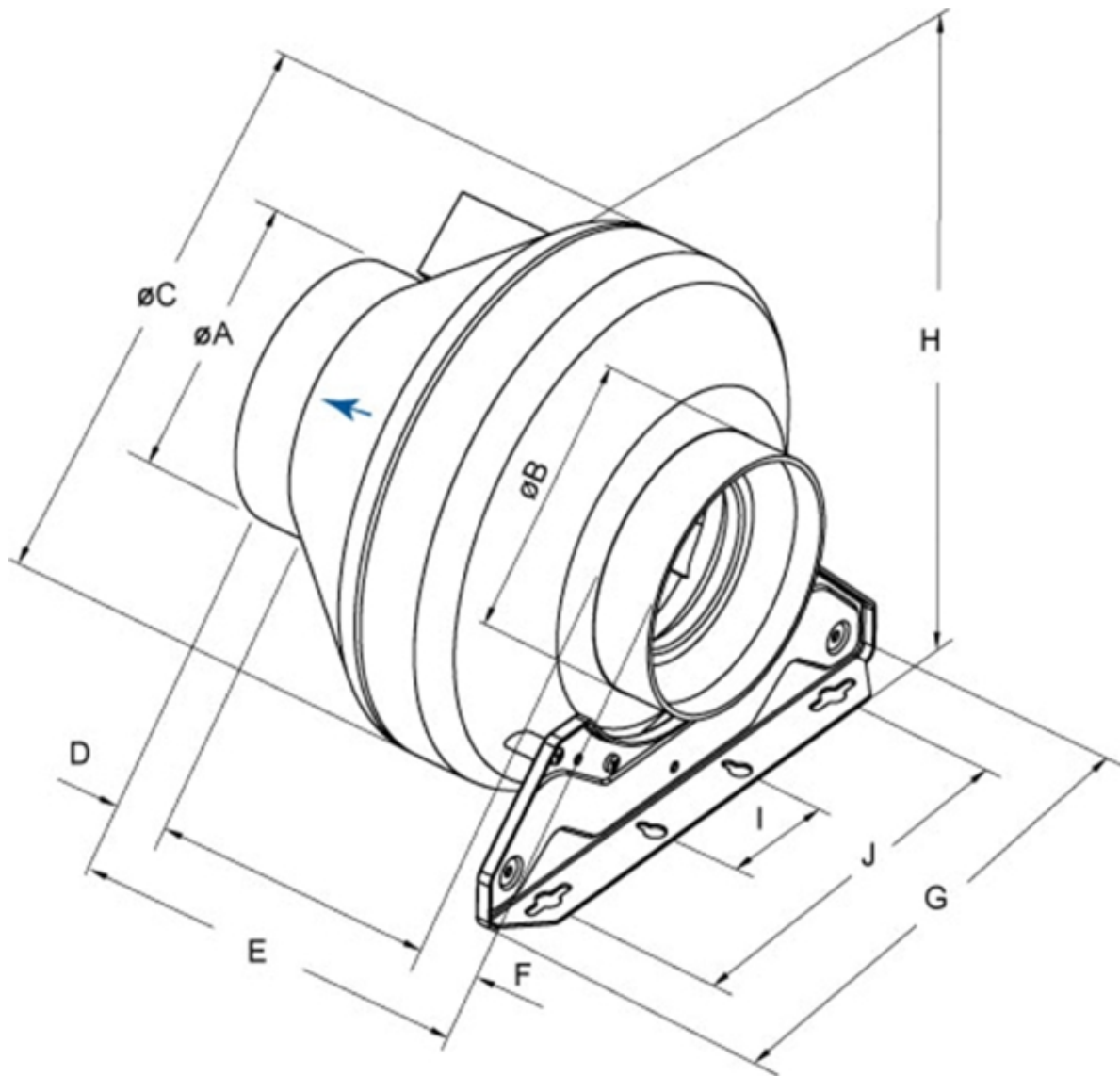

	øA	øB	øC	D	E	F	G	H	I	J
RVK 150	149	149	341	30	230	30	272	360	60	200

Name: **RVK 150E2-L SILEO 1PH/230V** | Item no.: **30341** | Version: **50 Hz**

Document type: **Product card** | Document date: **2019-06-24** | Generated by: **Online catalogue**

4 / 6

Get In Touch

Call: [0845 6880112](tel:08456880112)
 Email: info@adremit.co.uk

Our Address

Puravent, Adremit Limited, Unit 5a, Commercial Yard,
 Settle, North Yorkshire, BD24 9RH

230V 1~

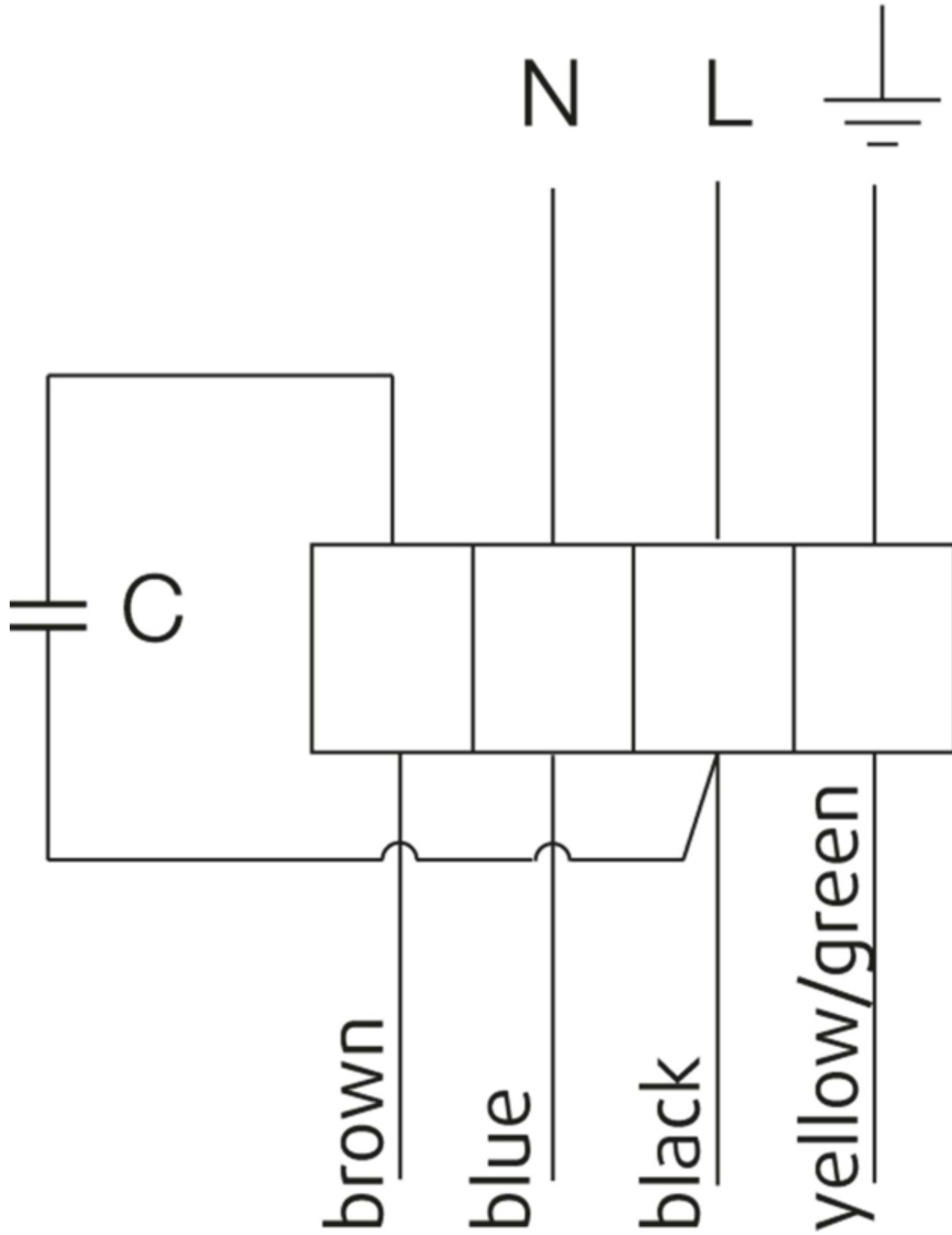

Get In Touch

Call: [0845 6880112](tel:08456880112)
Email: info@adremit.co.uk

Our Address

Puravent, Adremit Limited, Unit 5a, Commercial Yard,
Settle, North Yorkshire, BD24 9RH

Accessories

Electric accessories

[RE 1.5 Speed control \(5000\)](#)

[REU 1.5 Speed control \(5004\)](#)

[REE 1 Speed control \(5314\)](#)

[STL 1.5 Speed controller \(84251\)](#)

[REV-3POL/03 ON/OFF \(33978\)](#)

[FRQS-E-6A \(37419\)](#)

[FRQ5S-E-6A \(37421\)](#)

Accessories

[CB 150-1,2 230V/1 Duct heater \(5378\)](#)

[CB 150-2,1 230V/1 Duct heater \(5379\)](#)

[CB 150-2,7 230V/1 Duct heater \(5380\)](#)

[CBM 150-2,1 230V/1 Duct heater \(5481\)](#)

[LDC 150-600 Silencer \(5199\)](#)

[FFR 150 Filter cassette \(1769\)](#)

[FGR 150 Filter cassette \(1807\)](#)

[FK 150 Fast clamp \(1609\)](#)

[SG 150 Protection guard \(5555\)](#)

[RSK-150 Back draft damper \(5599\)](#)

[CB 150-5,0 400V/2 Duct heater \(5381\)](#)

Documentation



[manual_rvk_en_002.pdf \(3,32MB\)](#)



[PP compound \(30% glass fibre content\).pdf \(133,21kB\)](#)



[eu declaration of conformity_rvk_en_001.pdf \(47,90kB\)](#)



[rvk160_kpl.dxf \(799,15kB\)](#)

Specification text

RVK 250E2-XL Circular duct fan made of plastic. DN 250, 230V/50Hz, 1~, plastic casing Circular duct fan for easy and direct installation in ducts. The casing is manufactured from polyamide with 10% glass fibre content. Circular connection spigot, length 25mm, acc. to EN1506:1997 Free-running, backward curved centrifugal impeller made of plastic. Balancing made to G 6.3, motor compl. with impeller statically and dynamically balanced in two planes acc. to DIN ISO 1940 T.1. Voltage controllable external rotor motor, maintenance-free, the motor is placed inside the air flow for cooling. Integral thermal contacts with manual reset acc. to EN 60335-2-80, speed-controlled via a 5-step transformer or a stepless thyristor. Silent, long-life ball bearings. Terminal box on the casing Mounting bracket included in delivery (unmounted). For indoor installation. Installation in any mounting position. PRODUCT: SYSTEMAIR TYPE: RVK 250E2-XL Item no. 30901

Get In Touch



Call: [0845 6880112](tel:08456880112)



Email: info@adremit.co.uk

Our Address

Puravent, Adremit Limited, Unit 5a, Commercial Yard,
Settle, North Yorkshire, BD24 9RH