

Explosion proof fans EX 140A/180A – Presafe 16 ATEX 8598 X

Operation and Maintenance Instructions

GB

Document in original language | 135371 · A009

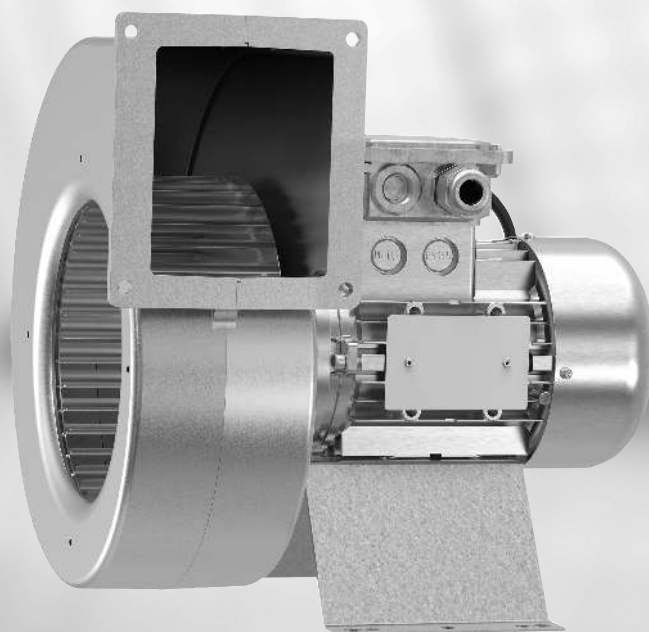

© Copyright Systemair AB
All rights reserved
E&OE

Systemair AB reserves the rights to alter their products without notice.
This also applies to products already ordered, as long as it does not affect the previously agreed specifications.

Contents

1	EU Declaration of conformity.....	1
2	Safety information.....	2
	2.1 Specific conditions of use (1-4)	4
3	Transport and storage	4
4	Technical data	5
	4.1 Dimensions.....	5
	4.2 Wiring.....	6
5	Installation.....	7
	5.1 Installation example.....	8
6	Checklist	9
7	Commissioning	9
8	Maintenance, service and repair	10
9	Other.....	11

1 EU Declaration of conformity

Manufacturer



Systemair Sverige AB
 Industrivägen 3
 SE-739 30 Skinnskatteberg SWEDEN
 Phone: +46 222 440 00
 www.systemair.com

The manufacturer hereby declares that the following products:

Centrifugal fans EX 140A/180A		
EU-type Examination Certificate (ATEX)	Presafe 16 ATEX 8598 X	DNV GL Nemko Presafe AS (2460)
Quality Assurance Notification (ATEX)	Presafe 16 ATEX 8871Q	DNV GL Nemko Presafe AS (2460)

(The declaration applies only to a product in the condition that it was delivered in and that was installed in the facility in accordance with the included installation instructions. The insurance does not cover components that are added or actions carried out subsequently on the product).

Comply with all applicable requirements in the following directives:

- ATEX Directive 2014/34/EU
- Machinery Directive 2006/42/EC
- EMC Directive 2014/30/EU

The following harmonized standards are applied in applicable parts:

EN 60079-0:2018	Explosive atmospheres – Part 0: Equipment - General requirements.
EN 60079-1:2014	Explosive atmospheres – Part 1: Equipment protection by flameproof enclosures "d"
EN 60079-7:2018	Explosive atmospheres – Part 7: Equipment protection by increased safety "e".
EN 14986:2017	Explosive atmospheres – Design of fans working in potentially explosive atmospheres.
EN ISO 12100:2010	Safety of machinery - General principles for design - Risk assessment and risk reduction.
EN ISO 13857:2019	Safety of machinery - Safety distances to prevent hazard zones being reached by upper and lower limbs.
EN 61000-6-2:2005	Electromagnetic compatibility (EMC) – part 6-2: Generic standards - Immunity for industrial environments.
EN 61000-6-3:2007	Electromagnetic compatibility (EMC) – part 6-3: Generic standards - emission standard for residential, commercial and light-industrial environments.

Skinnskatteberg 2021-11-30

Stefan Lindberg
 Technical Manager

Sofia Rask
 Managing Director

2 Safety information



Danger

- Before maintenance, service or repair cut the power supply (all-pole breaker) and the impeller to stop.
- Mounted safety equipment must not be removed, bypassed or be disabled!
- Cleaning with a damp cloth when the fan is energized can cause electric shock!

The installation instructions are part of the product and should be stored so that it is always available. The manufacturer of the system or the plant is responsible for the installation and that safety instructions are in harmony with the requirements.

EX 140A/180A are certified according to Directive 2014/34/EU (ATEX). Fan Category for fans is BV3 quality grade G6.3 according to ISO 14694. The motor rating plate (A, figure 1) shows data for the motor and does not apply for the complete fan. The fan rating plate shows data for the complete fan (B, figure 1). The field of explosion protection is stated on the fan rating plate (for example Ex de IIC T4). The fan fulfils the requirement for zone 1 but does not separate zones. Fan may be used in explosive environments for the transport of gas, but not the transport of hot fumes.

The fan is designed for transport of air or explosive atmospheres in Zone 1 and Zone 2. Transport of solids, shares of solids or mixtures of dust/air is not allowed. The transported air must not corrode the fan housing, fan blades or motor (aluminium and steel). Rust particles may not occur in the airflow.

Resonance vibrations can occur due to mounted components and should be checked during commissioning.

The fans must not be installed outdoors.

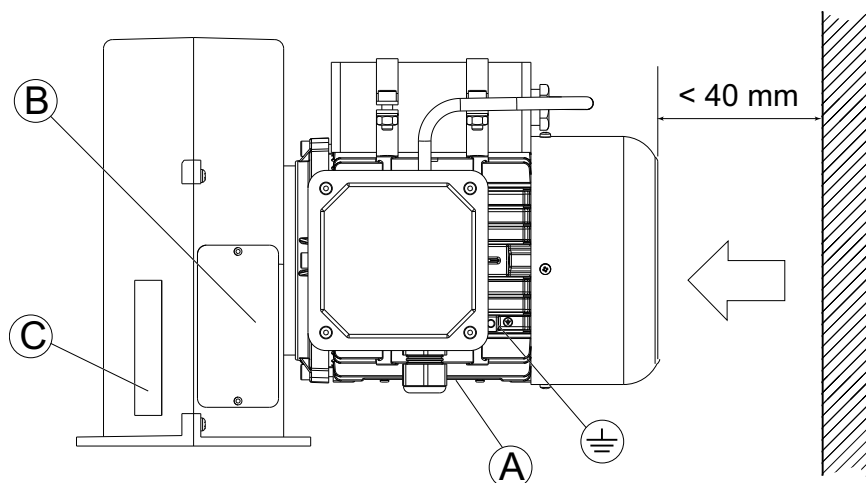

Fig. 1

A = Motor data

B = Fan data

C = Production label

Installation, electrical connection and commissioning may only be performed by qualified personnel and in accordance with the requirements and regulations for electrical installations in areas with explosive atmospheres.

Installation, inspection and maintenance in accordance with EN 60079-14/-17 meets the requirements. Fan should be installed and protected against foreign objects that come in contact with moving parts and may cause sparks.

No moving parts should be accessible after installation (EN ISO 13857).

Inspection and cleaning should be done regularly, cleaning of deposits will prevent imbalance of the impeller. Make sure that all the details are correctly reassembled after inspection/cleaning (see chapter 8).

Protective earth (PE) must be connected, the external ground wire connection is placed on the motor (figure 1). Electrical connections must be made according to the wiring diagram. When the fan is controlled the current can increase at regulated voltage, the power must never exceed the rated power, see table 1. Data provided on the rating plate applies to air with density of 1.2 kg/m³.

Table 1

Rated data								
Fan type	Voltage/Frequency	P W	I A ¹	rpm min.–max.	Isol. class	Weight kg	Min. flow m ³ /h	Max. flow m ³ /h
Ex 140A-2	230V(Δ) 3~ 50Hz	725	2,44	1229-2988	F	10,0	100	1181
	380-415V(Y) 3~ 50Hz	736	1,46		F	10,0	100	1181
Ex 140A-2C	220-240V 1~ 50Hz	848	3,85	1320-2960	F	10,7	100	1260
Ex 140A-4	230V(Δ) 3~ 50Hz	171	1,20	820-1490	F	6,3	100	610
	380-415V(Y) 3~ 50Hz	178	0,73		F	6,3	100	644
	380-440V(Y) 3~ 60Hz	232	0,64	709-1805	F	6,3	100	722
Ex 140A-4C	220-240V 1~ 50Hz	178	1,05	625-1485	F	6,7	100	620
	220-240V 1~ 60Hz	218	0,94	545-1795	F	6,7	100	705
Ex 180A-4	230V(Δ) 3~ 50Hz	248	1,25	611-1486	F	6,4	100	875
	380-415V(Y) 3~ 50Hz	248	0,73		F	6,4	100	869
	380-440V(Y) 3~ 60Hz	364	0,70	491-1801	F	6,4	100	1049
Ex 180A-4C	220-240V 1~ 50Hz	234	1,18	450-1480	F	6,9	100	880
	220-240V 1~ 60Hz	323	1,39	370-1780	F	6,9	100	1010

¹ The current may exceed the rated current on the fan label as long as the total power consumption does not exceed the rated power value given.

Step	1	2	3	4	5
Voltages 1~	80V	105V	130V	160V	230V
Voltages 3~Y	95V	145V	190V	240V	400V
Voltages 3~D	55V	85V	100V	140V	230V

Motors are equipped with PTC resistors in triple execution. More than two PTC resistor chains may not be connected in series, as this can lead to indefinite suspension. Max. test voltage of PTC resistors are 2.5 V.

Inspection and maintenance of the temperature monitoring unit shall be made according to instructions and according to a time interval specified in the certificate and instruction manual of the temperature monitoring device.



Note:

Speed control using frequency inverter is not permitted. It is only permitted to use transformer-based controls for speed control. The fan current/power must not exceed the current/power specified on the fan rating plate at rated voltage. By increasing the static back pressure the fan can be throttled up to a lower current/power if the speed control is not in use.

2.1 Specific conditions of use (1-4)

1. Thermal protectors (PTC) applied in the motor windings shall be connected to an appropriate protection device conforming to EN 50495.
2. Ducts or sockets on inlet and outlet has to be protected with IP20 according to EN 60529
3. The fastening screws used for el. motor have to comply with quality 8.8 ISO 898-1.
4. The supply voltage must be within the values specified on table 2.

Table 2 Rating and ambient temperature

Model	Phase	Supply voltage	T _{amb}
EX 140A-2C	1	220-240V AC 50Hz	-20°C to +60°C
EX 140A-2	3	230V (Δ) AC 50Hz	-20°C to +60°C
		380-415V(Y) AC 50Hz	
EX 140A-4C, EX 180A-4C	1	220-240 AC 50Hz	-20°C to +60°C
		220-240V AC 60Hz	
EX 140A-4, EX 180A-4	3	230V(Δ) AC 50Hz	-20°C to +60°C
		380-415V(Y) AC 50Hz	
		440V(Y) AC 60Hz	

3 Transport and storage

The fan is packed at the factory to withstand normal handling during transit. Avoid blows and shock loads. Store the fan in a dry, dust-free place without damaging vibrations ($v_{eff} < 0.2 \text{ mm/s}$) to avoid bearing damage. Avoid long storage periods (we recommend max. 1 year). Before installing the fan, check the motor bearings for noise (spin the impeller carefully by hand).



Caution

Do not lift the fan in any cable, junction box or the impeller.

4 Technical data

4.1 Dimensions

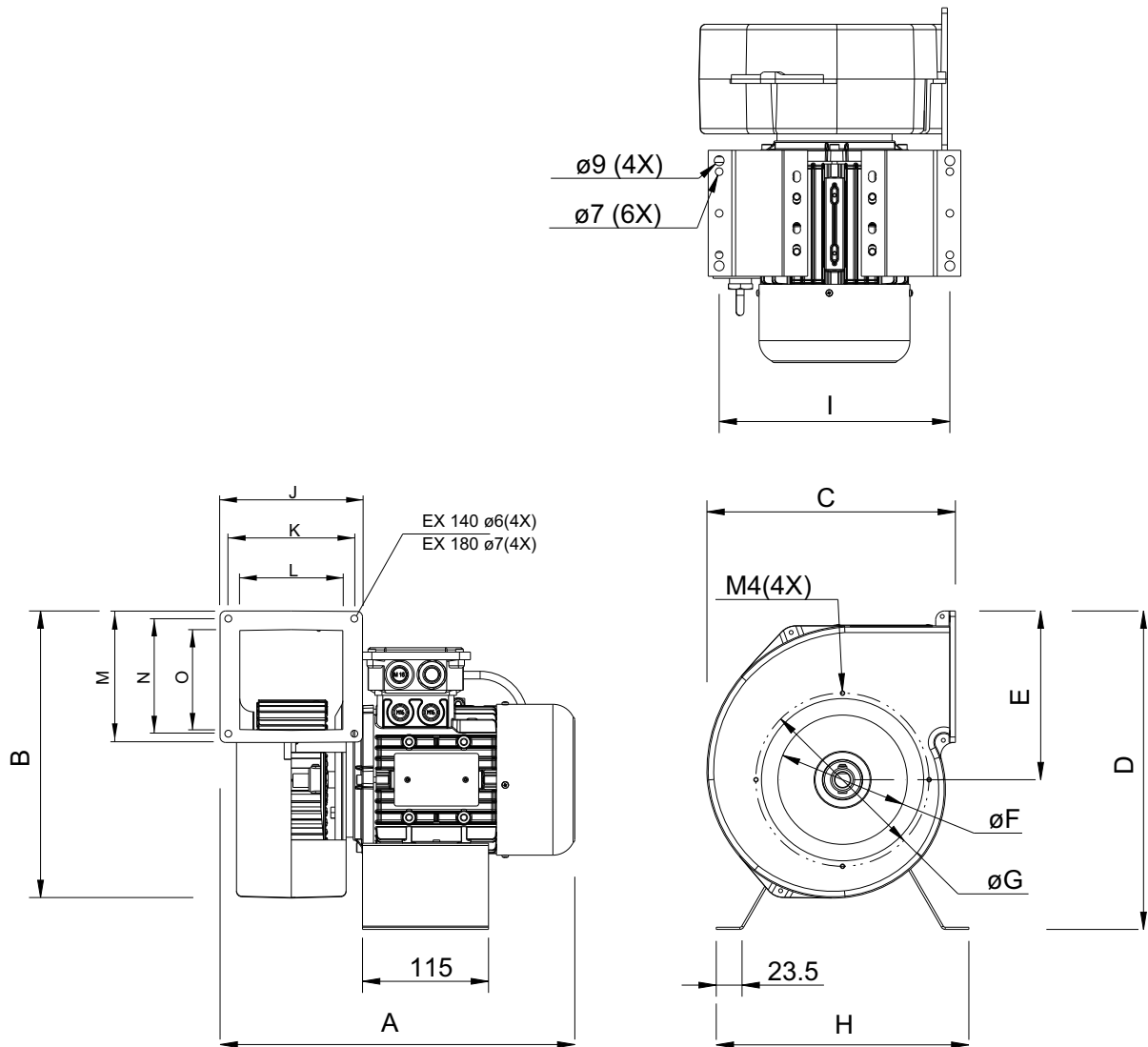

Model	A	B	C	D	E	$\varnothing F$	$\varnothing G$	H
EX 140A-4, EX 140A-4C	301	262	227	285	154	118	158	231
EX 180A-4, EX 180 A-4C	314	294	261	302	171	149	194	211
EX 140A-2, EX 140A-2C	324	262	227	291	154	118	158	211

Model	I	J	K	L	M	N	O	Weight, kg
EX 140A-4, EX 140A-4C	191,5	130	115	94	120	105	92	6,3/6,7
EX 180A-4, EX 180 A-4C	191,5	125	110	86	140	120	109	6,4/6,9
EX 140A-2, EX 140A-2C	210,5	130	115	94	120	105	92	10/10,7

4.2 Wiring

Ex 140A-2C, 140A-4C, 180A-4C

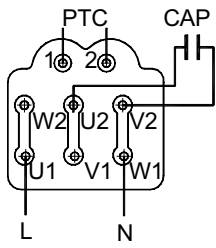

220-240V 1~

Ex 140A-2, 140A-4, 180A-4

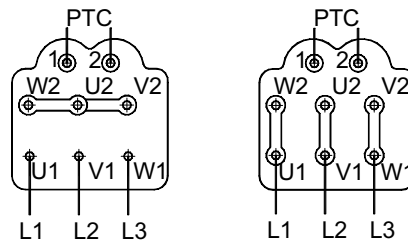

380-440V 3~ (Y)

230V 3~ (D)

Sample motor protection

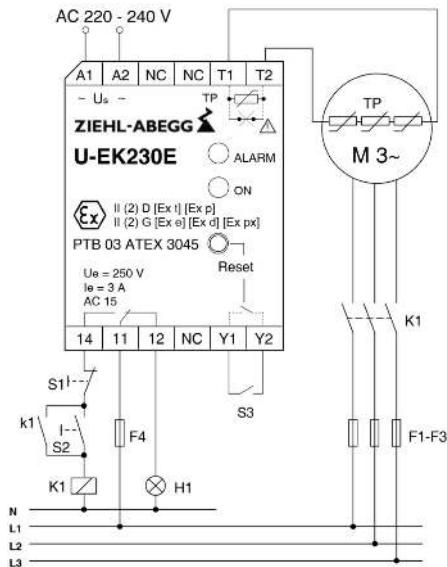

Us = supply voltage

S1 = off switch

S2 = push button on

S3 = push button external reset

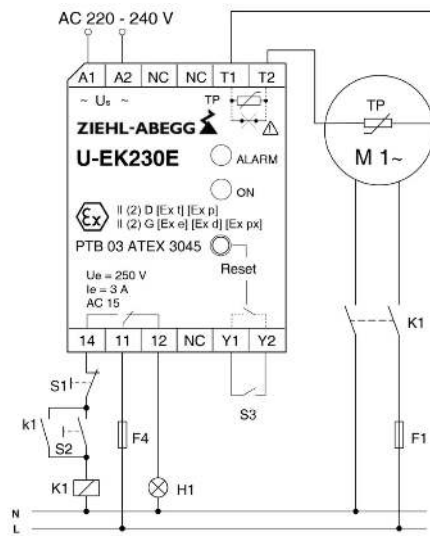

H1 = fault indicator

F1-F4 = fuses

K1 = contactor

TP = PTC thermistor

Sample wiring

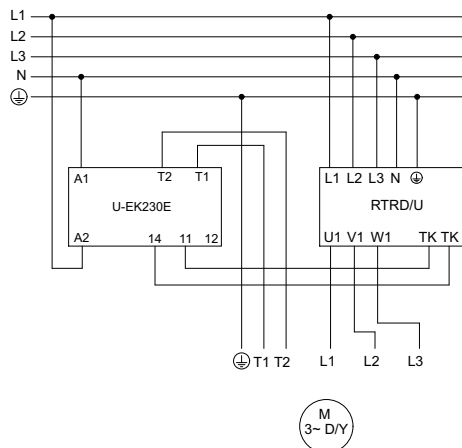
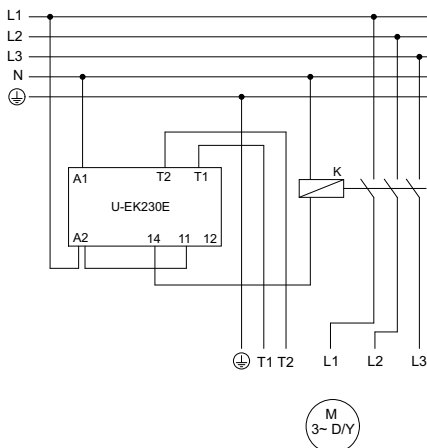

5 Installation

Always read the safety information before installation. The fan is intended for permanent installation. Installation requires an inspection of the hazardous area to be done according the regulations and classification standards (within the EU, EN 60079-10).

Installation according EN 60079-14 deemed to meet the installation requirements in the EU. Compliance with the Directive 2014/30/EU "Electromagnetic Compatibility" applies only when the product is directly connected. Integrated into an electrical system or combined with other components (e.g. controls/control equipment) the installer/plant holders are responsible for compliance.

The installation must be set up at a safe distance to transmitter units or protected with suitable screens.

Before starting installation check for any transport damage and that the impeller do not touch parts of the fan housing. Ambient temperature and the conveyed air temperature should be between -20°C and $+60^{\circ}\text{C}$ for all versions. EX 140A/180A are intended for operation within the specified temperature range. The motor is cooled by a integrated cooling fan which openings must not be covered, min. distance to the air intake is 40 mm (see figure 1). Avoid heat sources near the motor and the motor air intake.

The fan can be mounted in any direction. When the motor air intake is mounted upwards the intake must be protected against falling objects/liquid. Install EX 140A/180A in the correct air direction (arrow on housing), see figure 2. The fan must be installed so that service and maintenance can be performed easily and safely. Make sure the fan is firmly fixed and securely anchored. EX 140A/180A must be installed so that vibrations can not be transmitted to the duct system or building structure.

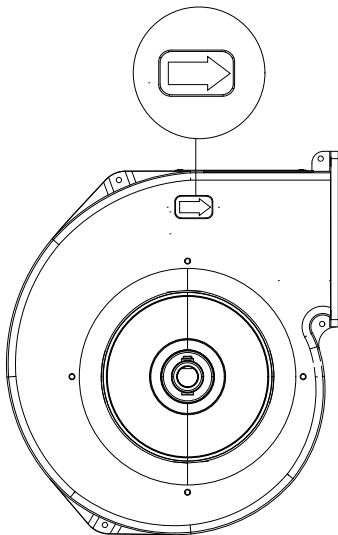

Fig. 2

Disturbing noise can be avoided by installing silencers (accessory).

Duct installations must be carried out so that enclosure class IP20 (mesh width below 12 mm) is fulfilled on the inlet side and outlet side. Parts that ensure the IP rating must be properly designed with regards to strength and material.

Rust particles must not occur in the airflow.

Components mounted before and after the fan or those that are in the direct air stream, may not have unprotected aluminium or steel surfaces. It requires a surface coating that meets minimum scratch test level 2 according to EN ISO 2409.

Mains circuit breaker must precede the fan. Electrical connections are made according to the wiring diagram, chapter 4.2. All fans for 3-phase (Δ/Y) are supplied from factory wired for 400V 3-phase (Y). If electrical connections are made inside the explosive environment then the used components must be intended for the relevant Ex environment.

If the distance to moving parts is such that one can touch the rotating part then a protective grille has to be installed, use an appropriate screw or rivet. Fan may not be mounted in direct sunlight.

Connection cable to the fan should be installed so that it is mechanically protected and suitable for use in the surrounding environment. Connection cable for the EX 140A/180A should have a diameter of 6.5 to 12 mm and a cross section of $1.5\text{--}2.5\text{ mm}^2$. The junction box on the motor is designed for the same environment as the fan. For external grounding of the chassis ground cable should be mounted on the grounding screw on the motor (figure 1).

Cleaning the fan is to be done after completion of assembly.

5.1 Installation example

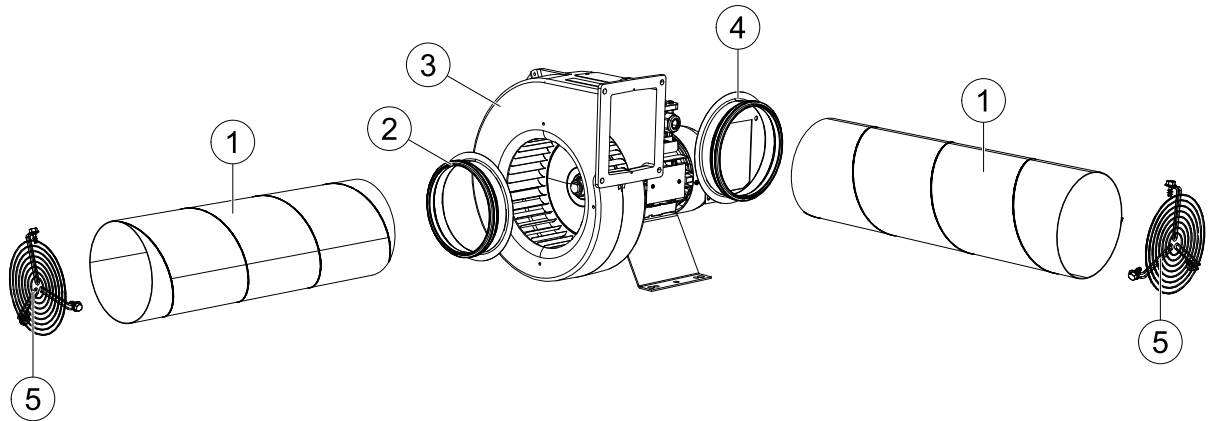

Fig. 3



Note:

Installation example (figure 3) works only as a guide for installation where the dimensioning of suspension devices must be carried out by the installer and adapted to the prevailing conditions. Installation components mentioned in the text are accessories that can be provided and not part of the ATEX-certification.

Mounting the fan (3). When connected to a duct system or protective grilles fit appropriate socket on the housing (inlet socket (2)/outlet socket (4)), then connect the duct (1) or protective grilles (5). On the fan intake section there are 4 pcs M4 threaded holes for fastening the inlet socket, screws must not protrude inside the housing (the housing thickness are 5 mm).

6 Checklist

Always read the safety instructions prior to commissioning. Before starting for the first time, ensure that:

- The ambient temperature, humidity, dirt in the environment and the air's corrosive properties have been taken into consideration.
- The impeller do not hit parts of the fan housing.
- Installation and electrical wiring are carried out in a professional manner
- Safety equipment is installed
- Any installation debris and foreign objects are removed from the impeller and air intake area.



Warning

Loose objects inside the housing may be flung out!

- Protective conductor and external earth conductor are connected.
- Cable glands are sealed
- PTC resistors and tripping device is connected and fully functional.
- Connection data corresponds with the data on the rating plate: Max. voltage +6%, -10%, according to IEC 38. Rated current/power must not be exceeded at rated voltage.
- The voltage is permitted to vary down to 80 V (1~) and 95 V (3~) with transformer.
- The motor cooling fan must have clearances of at least 40 mm (see figure 1.)

7 Commissioning

Commissioning may only take place if all safety instructions and controls according the checklist is performed without comment. When putting into operations check that:

- No moving parts is touching the housing.
- The impeller direction of rotation is correct (direction arrow on housing, see figure 2).
- The motor runs smoothly without abnormal noise and that the operation is without vibrations. (Strong vibrations due to imbalance, e.g. caused by transport damage or improper handling can lead to damage, check for imbalance as necessary.)
- All electrical conducting components are grounding through contact washers.
- The fan is not controlled by extensive on and off regulation.
- The motor are intended for continuous operation S1. The control system cannot permit large numbers of switching.
- A-weighted sound pressure levels above 70 dB(A) can occur, see the product catalogue.



Note:

If the fan is stationary for longer than a week in a damp environment it must be in operation for at least 2 hours every week to remove any condensation in the motor.

8 Maintenance, service and repair



Caution

Always read the safety information before maintenance or service.

Repair or replacement of components is not permitted on EX 140A/180A. For other questions about the fan, contact technical support. Cleaning interval should be in proportion to how fast the impeller and cooling fan becomes dirty. Disassembly of the impeller is not allowed.

Check that:

- The installation is accessible for cleaning and inspection work.
- No Ex atmosphere is present before switching of the fan.
- That the fan is not energized and the current circuit is interrupted and secured against restart.
- The impeller has stopped before any maintenance/cleaning begins.
- Applicable health and safety regulations are followed (EN50 110, IEC 364).



Danger

Cleaning with fluids when the fan is connected to voltage can cause an electric shock – danger to life!

- Under no circumstances may a high pressure cleaner or water jet be used.
- No aggressive solvents may be used as cleaning agents
- The cleaning should be carried out on the flow area and cooling air in/outlet area.
- Loose screws must be attached
- If the motor protection has tripped, check that the fan is not blocked. Contact the manufacturer if the fan does not start after you have checked and reset motor protection.
- Cable glands on the motor must have at least the same Ex class as the fan, see figure 4.

After maintenance or servicing, check that:

- There is no abnormal noise and that the operation is without vibrations.
- The impeller balance weights have not been moved and that the impeller blades have not been bent.

9 Other

The fan should be inspected and cleaned when necessary but at least once a year so that imbalance and excessive wear on the bearings is avoided. At any sign of wear, contact technical support. A filter before the fan inlet can extend the fan cleaning interval. At other damages (eg, cable and cable glands), please contact technical support.

If the screws need to be changed then the strength class of new screws must be at least 8.8 and with suitable screw locking. Required tightening torques M4=1,5 Nm, M5=2 Nm and M6=5 Nm. Cable glands=max. 5 Nm. Nuts in junction box at EX 140A/180A = 1,2 Nm.

Should fans be on stock or put into operation after a long period, or if they have been exposed to condensation during an extended period, the motor winding insulation resistance must be measured before the fan is put into operation. If the values are equal to/less than 1.5 Mohm, the motor winding must be dried. Contact technical support for instructions.

The fan mainly consist of recycled materials that can be recycled again when the service life of the product has ended. Check and follow the relevant legislation for recycling.

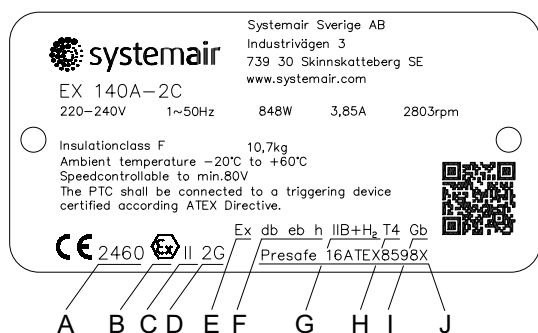

Fig. 4 Name plate

A	Id. nr. of Notified Body
B	The Epsilon-X mark indicates that the equipment comes under ATEX
C	Equipment group II is intended for use in areas with explosive gas, except mining gas
D	Category 2, zone 1, G = potentially explosive gas mixture can be occasionally expected to during normal operation.
E	Explosion-protected material
F	Type of protection
G	Gas group IIB + H ₂
H	Temperature class T4, max. surface temperature for fan housing and motor is 135 °C, can be used for gas mixtures with ignition temperature exceeding 135 °C.
I	EPL Equipment Protection Level
J	Certificate Number



Systemair Sverige AB
Industrivägen 3
SE-739 30 Skinnskatteberg, Sweden

Phone +46 222 440 00

www.systemair.com