

Instruction Sheet

SUPERSEDES: August 16, 2021

EFFECTIVE: July 27, 2023

Plant ID No. 001-5065

DESCRIPTION:

The 0018e® stainless steel is a variable speed wet rotor circulator with an ECM, permanent magnet motor. Operating modes include infinitely variable fixed speed, constant pressure, proportional pressure, and TacoAdapt™ self-adjusting proportional pressure. Adjust the operating mode with the dial or the Taco 0018e® ECM Circulator Mobile App using Bluetooth® connectivity on your smartphone or tablet. The ECM high-efficiency motor reduces power consumption by up to 85% compared to equivalent AC permanent split capacitor circulators.

APPLICATION:

- Maximum operating pressure: 150 psi (10 bar)
- Maximum water temperature: 230°F (110°C)
- Electrical specifications:
 - Voltage: 110-120V, 50/60 Hz, single phase
 - Maximum operating power: 44W
 - Maximum amp rating: 0.54
- Equipped with a stainless steel casing with 4-bolt universal flanges or 1" union connections
- Use on open loop potable hot water recirculation systems with up to 1000 feet of pipe or closed loop hydronic heating systems
- Not suitable for chilled water systems
- Taco circulator pumps are for indoor use only – employer uniquement a l'intérieur
- Acceptable for use with water or maximum of 50% water/glycol solution

FEATURES:

- 3 operating modes in dial activation:
 - Proportional pressure (TRV - Panel Radiator), variable speed - 2 variable pressure differential settings (Med or High)
 - Constant pressure (ZV - Zone Valve), variable speed - 2 constant pressure differential settings (Med or High)
 - Fixed speed (ZONE CIRC - zoning with circulators) - infinitely adjustable MIN/MAX settings
- 4 operating modes in 0018e™ Mobile App activation:
 - Fixed Speed - infinitely adjustable MIN/MAX settings
 - Constant Pressure - variable speed - 9 constant pressure differential settings
 - Proportional Pressure - variable speed - 9 variable pressure differential settings
 - **TacoAdapt™** - Designed for constant circulation systems. Automatically adjusts to system conditions
- Multi-color LED display showing operating mode and error code diagnostics
- Nut capture feature on flanges for easier fit up
- Dual electrical knockouts and 6" stranded wire leads for easy wiring
- Double insulated - no ground-wire required
- Whisper quiet operation
- **SureStart®** - automatic unblocking and air purging mode
- 4-bolt universal flange or 1" union connection, stainless steel casing
 - Optional 1/2" & 3/4" union fittings sets available - sweat, NPT or press (sold separately)
- Integral Flow Check (IFC®) included - Field installed

Figure 1:

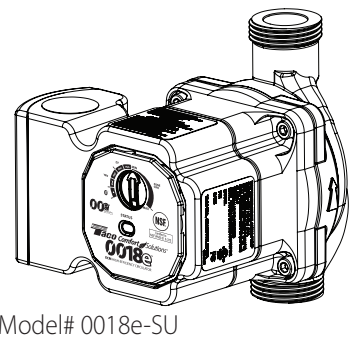
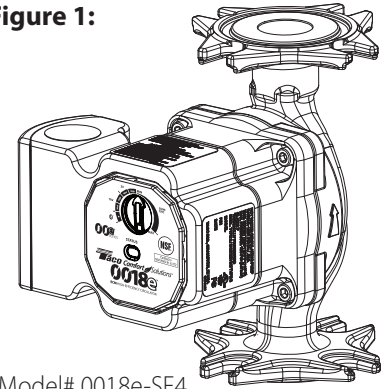

Certified to
NSF/ANSI/CAN 61
& 372



The Bluetooth® word mark and logos are registered trademarks owned by Bluetooth SIG, Inc. and any use of such marks by Taco Comfort Solutions is under license.

INSTALLATION:

WARNING: Do not use in swimming pool or spa areas. Pump has not been investigated for these applications.
AVERTISSEMENT : Ne pas utiliser dans une piscine ou un spa. La pompe n'a pas été étudiée pour ces applications.

CAUTION: The addition of petroleum based fluids or certain chemical additives to systems using TACO equipment voids the warranty. Consult factory for fluid compatibility.

ATTENTION : L'ajout de liquides à base de pétrole ou de certains additifs chimiques à des systèmes utilisant un équipement TACO annule la garantie. Consultez le fabricant pour connaître la compatibilité de liquides.

CAUTION: Installations at elevations over 5000 feet must have higher fill pressure of 20 psi minimum to prevent pump cavitation and flashing. Premature failure may result. Adjust expansion tank pressure to equal fill pressure. A larger size expansion tank may be required.

ATTENTION: Des installations à des altitudes de plus de 1600 mètres doivent présenter une pression de remplissage plus élevée de 20psi au minimum afin d'éviter toute cavitation ou flashing de la pompe. Une défaillance prématurée peut en résulter. Réglez la pression du réservoir d'expansion de façon qu'elle soit égale à la pression de remplissage. Un réservoir d'expansion d'une taille supérieure peut être nécessaire.

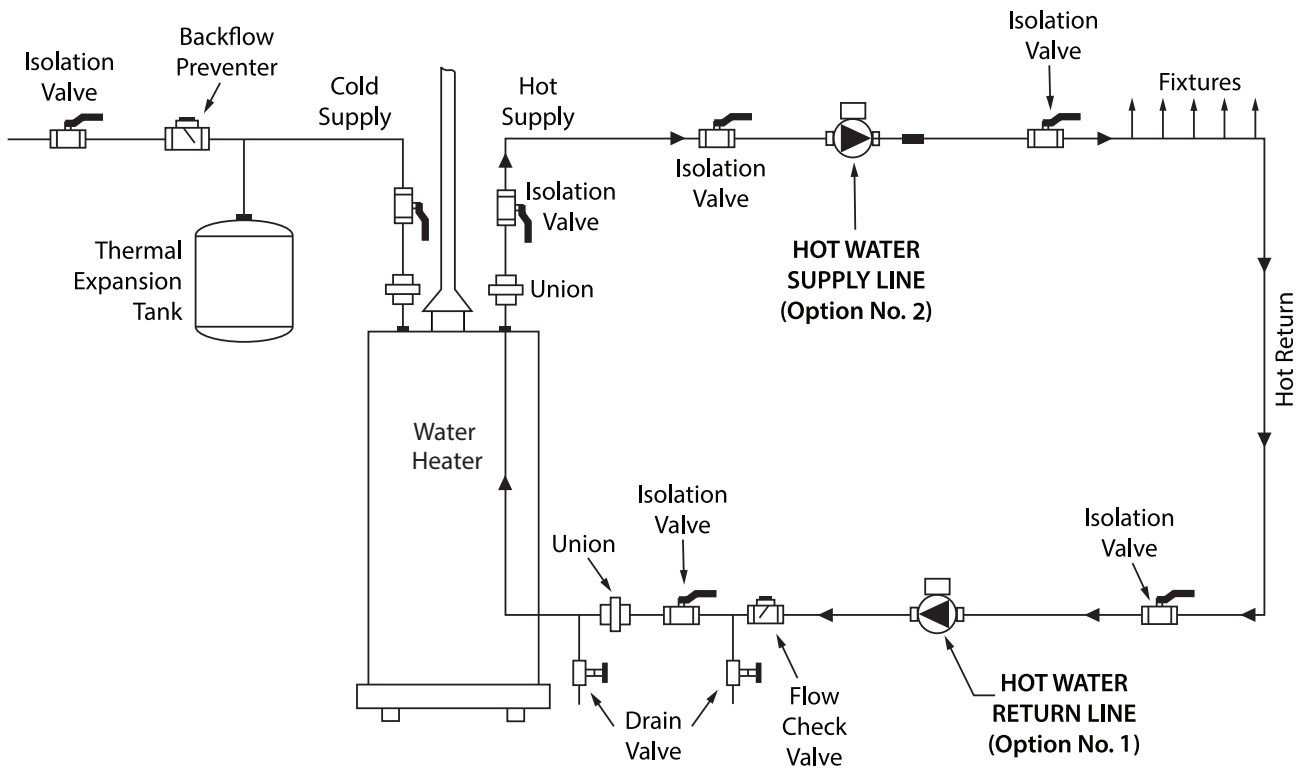

Figure 2:
Typical Installation for
Hot Water Recirculation Systems

Recommended Purging Steps:

1. Open fixture at highest point in system
2. Open all isolation valves
3. Once system is filled, close the fixture at the highest point in the system
4. Close isolation valve on pump discharge (Option No. 1 location)
5. Open drain valve on pump discharge until all remaining air has been purged
6. Close drain valve
7. Operate pump until all remaining air is purged from bearing chamber

ACCEPTABLE MOTOR MOUNTING POSITIONS AND EASY CASING ROTATION

Figure 4:

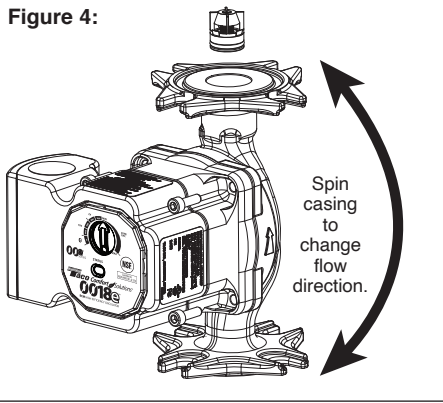

Always install with motor in horizontal orientation. Position electrical junction box at 9 o'clock for best viewing orientation. Pump casing may be rotated to change flow direction. Locate the arrow on the casing body to determine flow direction.

Figure 5:

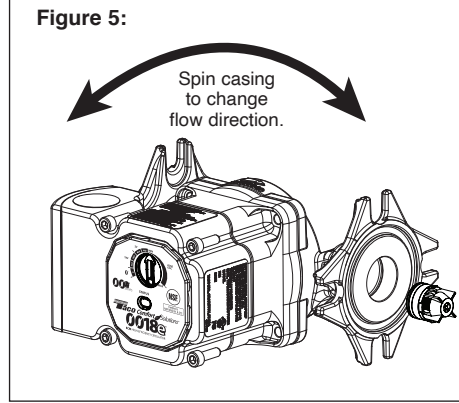

To rotate the pump casing, remove the 4 motor screws. When rotating pump casing position, DO NOT detach motor housing from the casing. Damage to the casing O-ring and leakage may result. Simply spin casing to the proper flow direction desired as shown in Figure 4 and Figure 5. Reattach the 4 screws (1/8" allen wrench required). Be sure motor is positioned correctly and is seated evenly to prevent leakage or damage to O-ring. Tighten motor screws evenly to 25-38 in-lbs torque.

Figure 6: Do not detach motor from pump casing. Simply spin casing to the proper flow direction.

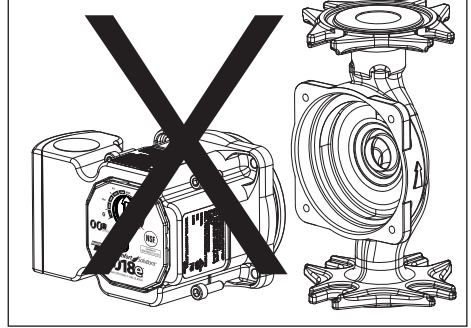

Integral Flow Check (IFC®) option - An IFC® is included in the carton. If required, press IFC into machined discharge port with plunger and o-ring facing in, until it snaps into place. Before installing, press IFC plunger to be sure it moves freely. See diagram above.



CAUTION: To reduce the possibility of noise transmission, be sure to add vibration dampeners to piping when mounting circulator to wall or floor joists.

ATTENTION: Pour réduire la possibilité de transmission de bruit, veuillez à ajouter des amortisseurs de vibration à la tuyauterie lors du montage du circulateur sur des chevêtres de mur ou de plancher.

5. Filling the system: The system must be filled before operating the circulator. The bearings are water lubricated and should not be allowed to operate dry. Filling the system will result in immediate lubrication of the bearings. It is always good practice to flush a new system of foreign matter before starting the circulator.



WARNING: Risk of electric shock. To reduce the risk of electric shock, be certain that it is connected only to a properly grounded, grounding-type receptacle. Follow all local electrical and plumbing codes.

AVERTISSEMENT: Risque de choc électrique. Pour réduire le risque de choc électrique, veuillez à ce qu'elle soit raccordée uniquement à un réceptacle de type mise à la terre proprement mis à la terre. Respectez tous les codes de plomberie et électriques locaux.



WARNING: Use supply wires suitable for 90°C. **AVERTISSEMENT:** Employer des fils d'alimentation adéquats pour 90°C.



WARNING: Disconnect power when servicing. **CAUTION:** Use flexible conduit only. Not for use with rigid conduit.



WARNING: SERVICING OF DOUBLE-INSULATED APPLIANCES. A double-insulated appliance is marked with one or more of the following: The words "DOUBLE INSULATION" or "DOUBLE INSULATED" or the double insulation symbol (square within a square). In a double-insulated appliance, two systems of insulation are provided instead of grounding. No grounding means is provided on a double-insulated appliance, nor should a means for grounding be added. Servicing a double-insulated appliance requires extreme care and knowledge of the system, and should be done by qualified service personnel. Replacement parts for a double-insulated appliance must be identical to the parts they replace.

6. Wiring the circulator: Disconnect the AC power supply. Remove the terminal box cover. Attach a wiring connector into the knockout hole. Use a flexible conduit only. Connect Line/Hot power to the black lead, neutral to the white lead. See wiring diagram to the right. Replace the terminal box cover.

Note: If pigtail leads provided are not used, be sure to trim field wire to a strip length of .25" (+/- .025") to prevent exposed wire causing a short at the terminal plug. Connect line and neutral to green terminal plug as shown in the Wiring Diagram. Depress the spring tab with a small screwdriver to insert wire into the plug. Release tabs to complete connection. The 0018e is a double insulated circulator. No grounding wire is necessary.

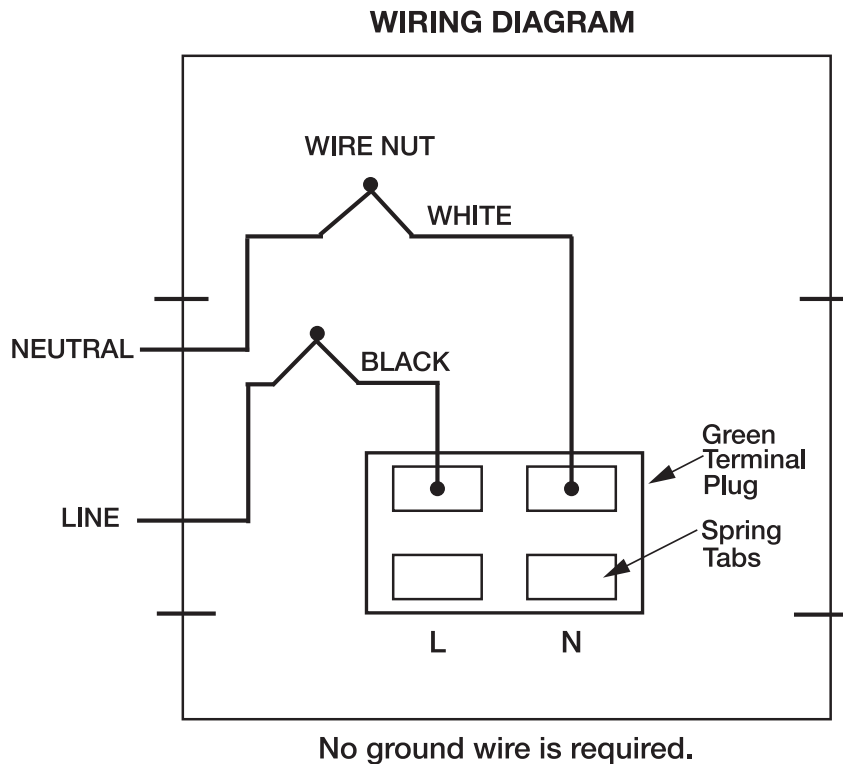

7. Start the circulator: When purging the system, it is recommended to run the circulator at manual full speed operation long enough to remove remaining air from the bearing chamber. To do this, turn the dial clockwise to the ZONE CIRC - MAX position. This is especially important when installing the circulator in the off-season.

Full Speed Operation: To run the pump at full speed during the fast fill, start-up and purge process, rotate dial clockwise to MAX speed setting. To return to the normal operating mode, turn dial to desired fixed speed, constant pressure, or proportional pressure setting.



CAUTION: Never run the circulator dry or permanent damage may result.

ATTENTION: Ne laissez jamais le circulateur tourner à sec, des dommages permanents peuvent en résulter.

8. Programming your 0018e circulator:

a. Taco 0018e ECM Circulator Mobile App - www.TacoComfort.com/0018e_UserManual

1. Search for Taco 0018e ECM Circulator mobile app within the App Store or Google Play on your mobile device.
2. Download the Taco 0018e ECM Circulator mobile app for free and install it on your mobile device.
3. Once complete, you are able to start using the app. Additional operating instructions can be found on the app itself.



Turn the selector dial counter-clockwise to the Bluetooth® setting icon for 2-way (read/write) communication & control using the 0018e mobile app. This will enable wireless mode selection control, performance diagnosis & reporting. In this dial position, *SureStart*® capability is disabled. When the selector dial is turned to any other position the 0018e mobile app can be used for 1-way (read only) communication, providing performance diagnosis & reporting.

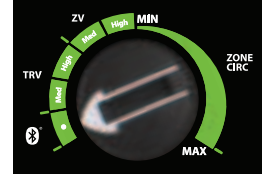

Minimum software requirements:

- iOS version 10 (BLE compatible)
- Android version 4.4 (BLE compatible)

b. Manual Dial

Note: The 0018e is factory-programmed for maximum speed operating mode. A Blue LED will appear when first powered on. If this is your desired operating mode, no programming changes are required.

The 0018e has 3 Operating Modes on the Selector Dial:

- **Proportional Pressure (TRV) - Varies speed to maintain a proportional/variable pressure differential.**
- **Constant Pressure (ZV) - Varies speed to maintain a constant pressure differential.**
- **Fixed Speed (ZONE CIRC) - Infinitely adjustable settings (MIN-MAX).**

To change operating mode and settings:

Modify the performance of the circulator as needed by rotating the dial using a flat screwdriver. When an operating mode is changed, a blue, orange or green LED will illuminate when the circulator is powered on. The LED will flash each time mode is changed. See diagrams below to determine best mode of operation for the system. The selection of the right functioning curve depends on the characteristics of the heating system and the actual heat demand.

0018e Performance Curves

TRV - PANEL RADIATOR MODE Variable Speed

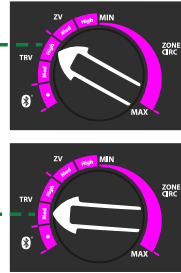
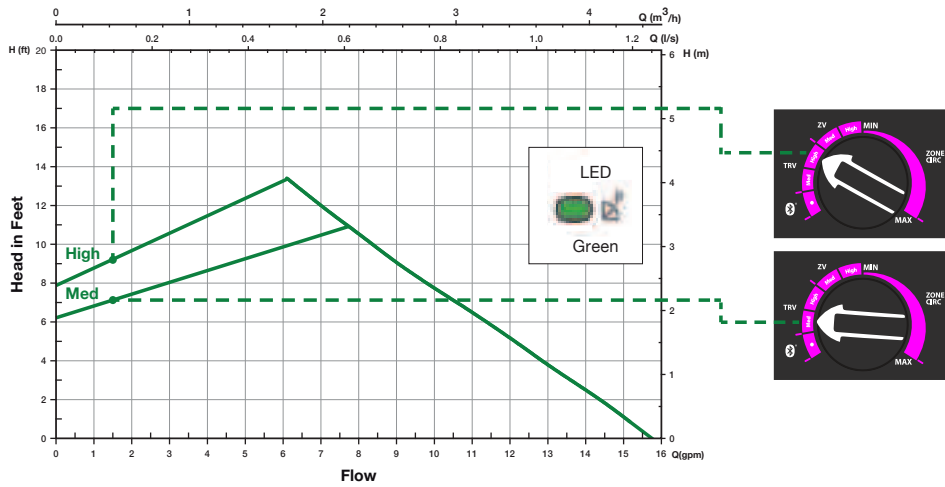

In TRV - Panel Radiator, Proportional pressure mode, the circulator maintains a proportional pressure differential ($\Delta p-v$) as heating load increases or decreases. Flow will change in relationship to the change in pressure differential. Selection options are Medium or High. If unsure on proper setting, select Medium and adjust as needed.

ZV - ZONE VALVE SYSTEM MODE Variable Speed

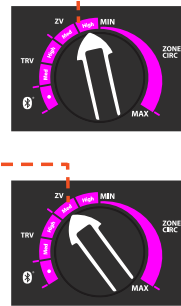
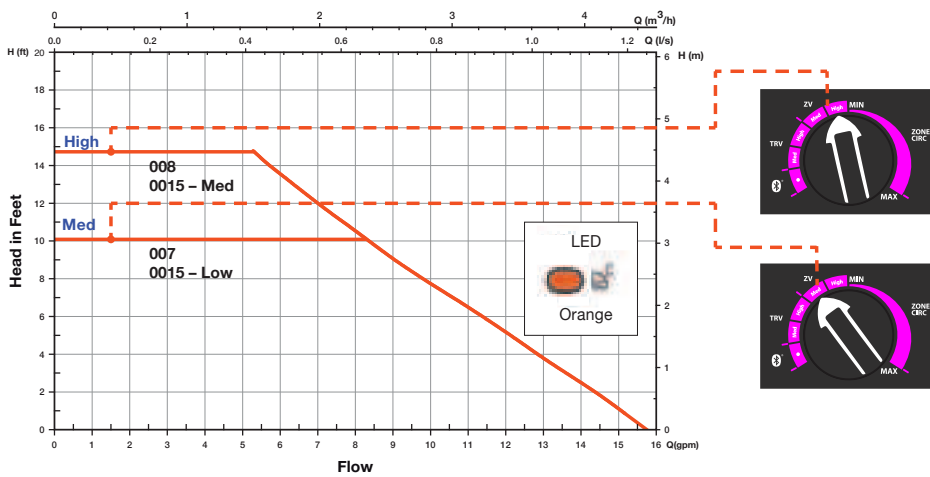

In Zone Valve - Constant pressure mode, the circulator maintains a constant pressure differential ($\Delta p-c$) in the system as heating load increases or decreases. Selection options are Medium or High. See chart to left for equivalent 00 model at each setting.

ZONE CIRC - FIXED SPEED MODE Infinitely Adjustable (MIN-MAX)

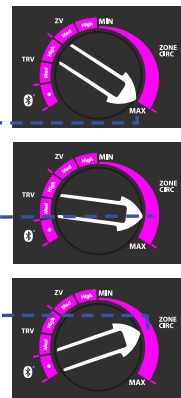
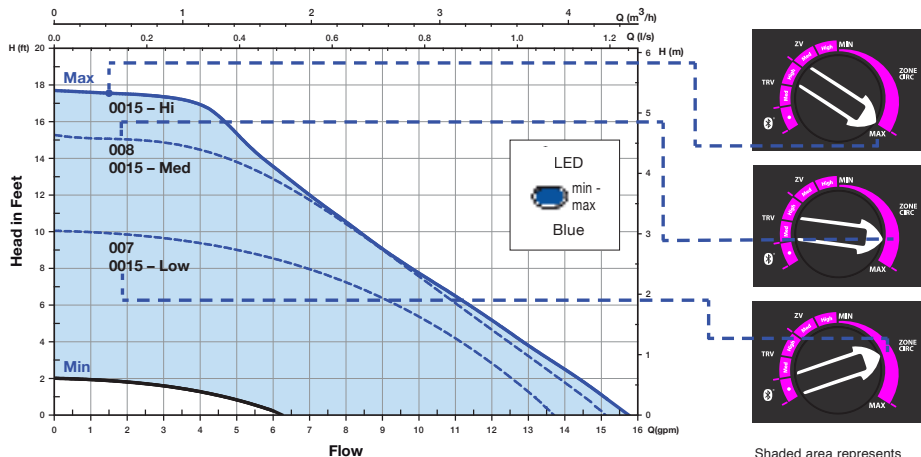

Shaded area represents full operating range.

Zone Circ - Fixed speed mode allows the installer to fine tune the circulator flow rate to precisely match design load conditions. It is infinitely variable between MIN/MAX settings. See chart to left for equivalent 00 model at each variable speed setting.



CAUTION: Do not attempt to remove LED panel from circulator. Serious damage to circulator electronics may result.

ATTENTION: N'essayez pas de retirer le panneau de LED du circulateur. Des dommages sérieux à l'électronique du circulateur peuvent en résulter.

7. Troubleshooting the error codes: Listed below are potential diagnostic error codes which will appear on the LED display in case of a malfunction.

FAULTS	CONTROL PANEL	CAUSES	REMEDIES
The circulator is noisy	LED on	Suction pressure is insufficient — cavitation	Increase the system suction pressure within the permissible range.
	LED on	Presence of foreign bodies in the impeller	Disassemble the motor and clean the impeller.
Loud noises of water circulation	Flashing white LED	Air in the system. Pump may be air-bound	Vent the system. Repeat fill and purge steps.
	LED on	The flow is too high	Reduce the pump speed.
Circulator is not running although the electrical power supply is switched on	LED off	Lack of power supply	Verify voltage value of the electric plant. Verify the connection of the motor.
		One fuse in the installation is blown	Verify the fuses of the pump.
		The circulator is defective	Replace the pump.
		Overheating	Let the pump cool down for some minutes. Then try to re-start it. Verify that the water and ambient temperature are within the indicated temperature ranges.
	LED red	The rotor is blocked	Disassemble the motor and clean the impeller. See unlocking procedure below.
		Insufficient supply voltage	Verify that the power supply matches the data on the name plate.
Building does not get warm.	LED on	The circulator performance is too low	Increase the suction head. Increase speed or P setting.

Unlocking Procedure: A red light in the LED indicates the circulator rotor is blocked or sticking. Turn the selector to the position MAX, disconnect and connect power supply to start the automatic release process. The circulator makes 100 attempts to restart (process lasts approximately 15 minutes). Every restart is signalled by a short flash of white LED light. If the blocking is not removed through the automatic release process after 100 attempts to restart, the circulator goes into standby and the LED remains solid red. Perform the manual unblocking steps described below.

1. Disconnect power supply - the warning light switches off.
2. Close both isolating valves and allow cooling. If there are no shut-off devices, drain the system so that the fluid level is beneath that of the circulator.
3. Loosen 4 motor bolts. Remove motor from casing. Carefully pull the rotor/impeller from the motor.
4. Remove impurities and deposits from the impeller and casing.
5. Reinsert the rotor/impeller into the motor.
6. Set the dial to the MAX position.
7. Connect power supply. Check for impeller rotation.
8. If the circulator still doesn't run it will need to be replaced.

REPLACEMENT PARTS	
Part#	Description
198-213 RP	Casing O-ring
198-214 RP	Wiring plug connector (green)
198-215 RP	Terminal box cover (black)
198-217 RP	Terminal box cover screws (5 per bag)
0010-025 RP	Integral Flow Check (IFC®)
007-007 RP	Flange Gasket Kit

Lead-Free Shut-Off <i>freedom</i> FLANGE (SOLD SEPARATELY)	
Part#	Description
SFL-050T	1/2" NPT
SFL-050S	1/2" Sweat
SFL-075T	3/4" NPT
SFL-075S	3/4" Sweat
SFL-100T	1" NPT
SFL-100S	1" Sweat
SFL-125T	1-1/4" NPT
SFL-125S	1-1/4" Sweat
SFL-150T	1-1/2" NPT
SFL-150S	1-1/2" Sweat

UNION FITTING SETS (SOLD SEPARATELY)	
Part#	Description
UFS-050S	1/2" Sweat tailpiece set
UFS-050T	1/2" NPT tailpiece set
UFS-050P	1/2" Press tailpiece set
UFS-075S	3/4" Sweat tailpiece set
UFS-075T	3/4" NPT tailpiece set
UFS-075P	3/4" Press tailpiece set

0018e Pump Replacement Cross Reference (Fixed Speed Mode):

SPEED	Taco	Grundfos	Wilo	Xylem/B & G	Armstrong
Minimum	003 006	--- Alpha 15-55 (Low)	---	---	Compass (1)
Medium	007 008 0015 (Low) 0015 (Med)	UP-15-42 UPS-15-58 (Low) UPS-15-58 (Med) Alpha 15-55 (Med)	Star S-21 (1) Star S-21 (2)	NBF (1 & 2)	Astro 230 (1) Astro 230 (2) Compass (2)
Maximum	0015 (Hi)	UPS-15-58 (Hi) Alpha 15-55 (Hi)	Star S-21 (3)	NBF/NRF-25 (3)	Astro 230 (3) Compass (3)

0018e Pump Replacement Cross Reference (Variable Speed Mode):

Taco	Grundfos	Wilo	Xylem/B & G	Armstrong
VR1816 0015e3 007e	Alpha 15-55	Stratos Eco	ecocirc 19-16 ecocirc 20-18	Compass 20-20

CAUTION

This equipment has been tested and found to comply with the limits for a Class B digital device, pursuant to part 15 of the FCC Rules. These limits are designed to provide reasonable protection against harmful interference in a residential installation. This equipment generates, uses and can radiate radio frequency energy and, if not installed and used in accordance with the instructions, may cause harmful interference to radio communications. However, there is no guarantee that interference will not occur in a particular installation. If this equipment does cause harmful interference to radio or television reception, which can be determined by turning the equipment off and on, the user is encouraged to try to correct the interference by one or more of the following measures:

Reorient or relocate the receiving antenna.

Increase the separation between the equipment and receiver.

Connect the equipment into an outlet on a circuit different from that to which the receiver is connected.

Consult the dealer or an experienced radio/TV technician for help.

This device complies with Industry Canada license exempt RSS standard(s). Operation is subject to the following two conditions:

(1) This device may not cause interference, and

(2) This device must accept any interference, including interference that may cause undesired operation of the device.

Le présent appareil est conforme aux CNR d'Industrie Canada applicables aux appareils radio exempts de licence. L'exploitation est autorisée aux deux conditions suivantes:

(1) l'appareil ne doit pas produire de brouillage, et

(2) l'utilisateur de l'appareil doit accepter tout brouillage radioélectrique subi, même si le brouillage est susceptible d'en compromettre le fonctionnement.

Under Industry Canada regulations, this radio transmitter may only operate using an antenna of a type and maximum (or lesser) gain approved for the transmitter by Industry Canada. To reduce potential radio interference to other users, the antenna type and its gain should be so chosen that the equivalent isotropically radiated power (e.i.r.p.) is not more than that necessary for successful communication.

Conformément à la réglementation d'Industrie Canada, le présent émetteur radio peut fonctionner avec une antenne d'un type et d'un gain maximal (ou inférieur) approuvé pour l'émetteur par Industrie Canada. Dans le but de réduire les risques de brouillage radioélectrique à l'intention des autres utilisateurs, il faut choisir le type d'antenne et son gain de sorte que la puissance isotrope rayonnée équivalente (p.i.r.e.) ne dépasse pas l'intensité nécessaire à l'établissement d'une communication satisfaisante.

To comply with FCC and Industry Canada RF radiation exposure limits for general population, the antenna(s) used for this transmitter must be installed such that a minimum separation distance of 20cm is maintained between the radiator (antenna) and all persons at all times and must not be co-located or operating in conjunction with any other antenna or transmitter.

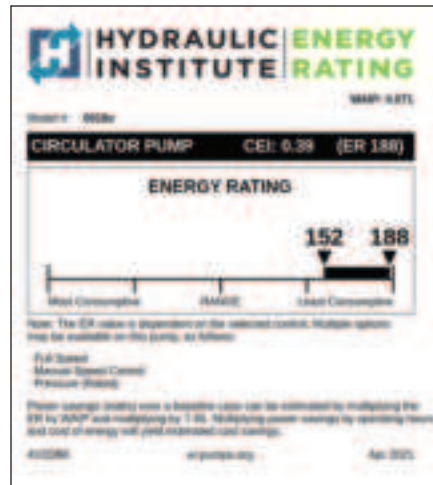

LIMITED WARRANTY STATEMENT

Taco, Inc. will repair or replace without charge (at the company's option) any Taco product which is proven defective under normal use within three (3) years from the date of manufacture.

In order to obtain service under this warranty, it is the responsibility of the purchaser to promptly notify the local Taco stocking distributor or Taco in writing and promptly deliver the subject product or part, delivery prepaid, to the stocking distributor. For assistance on warranty returns, the purchaser may either contact the local Taco stocking distributor or Taco. If the subject product or part contains no defect as covered in this warranty, the purchaser will be billed for parts and labor charges in effect at time of factory examination and repair.

Any Taco product or part not installed or operated in conformity with Taco instructions or which has been subject to misuse, misapplication, the addition of petroleum-based fluids or certain chemical additives to the systems, or other abuse, will not be covered by this warranty. If in doubt as to whether a particular

substance is suitable for use with a Taco product or part, or for any application restrictions, consult the applicable Taco instruction sheets or contact Taco at (401-942-8000).

Taco reserves the right to provide replacement products and parts which are substantially similar in design and functionally equivalent to the defective product or part. Taco reserves the right to make changes in details of design, construction, or arrangement of materials of its products without notification.

TACO OFFERS THIS WARRANTY IN LIEU OF ALL OTHER EXPRESS WARRANTIES. ANY WARRANTY IMPLIED BY LAW INCLUDING WARRANTIES OF MERCHANTABILITY OR FITNESS IS IN EFFECT ONLY FOR THE DURATION OF THE EXPRESS WARRANTY SET FORTH IN THE FIRST PARAGRAPH ABOVE.

THE ABOVE WARRANTIES ARE IN LIEU OF ALL OTHER WARRANTIES, EXPRESS OR STATUTORY, OR ANY OTHER WARRANTY OBLIGATION ON THE PART OF TACO.

TACO WILL NOT BE LIABLE FOR ANY SPECIAL INCIDENTAL, INDIRECT OR CONSEQUENTIAL DAMAGES RESULTING FROM THE USE OF ITS PRODUCTS OR ANY INCIDENTAL COSTS OF REMOVING OR REPLACING DEFECTIVE PRODUCTS.

This warranty gives the purchaser specific rights, and the purchaser may have other rights which vary from state to state. Some states do not allow limitations on how long an implied warranty lasts or on the exclusion of incidental or consequential damages, so these limitations or exclusions may not apply to you.

