

# Instruction manual



**PRO2.45**  
DIGITAL AUDIO PROCESSOR



The installation of this product must be made by a qualified professional.

# Index

- 01 • Term of Warranty
  - Technical assistance
- 02 • Introduction
  - Safety requirements
  - Important recommendations
  - Safety
- 03 • Processor Overview
  - Getting to know screens and basic operations
- 04 • Navigating through menus and parameters
- 05 • Menu structures and description
  - Audio menu
  - Input/output routing
- 06 • Input Graphic Equalizer
  - Input parametric equalizer
  - Crossover
- 07 • Alignment (delay)
  - How to set the alignment parameter value
- 08 • Phase
  - Limiter
- 09 • Outputs level
  - Eq. parameter. output
- 10 • Audio generator
  - Language
  - Save Config.
- 11 • Load config.
  - Password / lock
  - Presets EQ
  - Text Message
- 12 • Connecting processor inputs and outputs
- 13 • Technical Features

## Term of warranty

TARAMPS, located on Abilio Daguano Street 274, Res. Manoel Martins – Alfredo Marcondes, SP - Brazil, ZIP CODE 19180-000, guarantees this product against any defects on terms of project, making, assembling, and/or with solidarity, due to project vices which cause it improper or inadequate to its original use within 12 months from the date of purchase. In case of defect during the warranty period, TARAMPS responsibility is limited to the repairing or substitution of the device of its own making.

### This warranty excludes:

- Damaged products by improper installation, water infiltration, violation by unauthorized individuals;
- Tamper or torn warranty seal;
- Cases in which the product is not used in adequate conditions;
- Defects caused by accessories, modifications or features attached to the product;
- The product with damage from falling, bumps or nature related problems (flooding, lightning, etc.);
- Warranty card is not properly filled or torn;
- Costs involving uninstallation, reinstallation of equipment as well as shipment to the factory;
- Damage of any kind, due to problems in the product, as well as losses caused by discontinued use of the product.

## Technical assistance

For international support, check on our website:

[www.taramps.com.br/en/rede-de-assistencias-tecnicas](http://www.taramps.com.br/en/rede-de-assistencias-tecnicas) or contact direct the factory support:

Phones: +55 18 3266-4050 / +55 18 99749-3391

E-mail: [service@taramps.com.br](mailto:service@taramps.com.br)

## Introduction

Read this manual before installing the product. In case of questions contact our technical support:

+55 (18) 3266-4050 or [www.taramps.com.br](http://www.taramps.com.br).

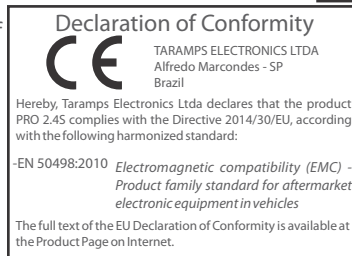

At the end of its lifespan, this product must not be disposed of in household waste. Look for an electronic equipment collection or recycling center for proper disposal.

## Safety requirements



To ensure proper use, please read through this manual before using the processor. It is specially important that you know the **WARNINGS** and **CAUTIONS** contained here.

- The installation of this product must be done by a qualified professional.
- Use the correct tools for installing this product.
- This product is for use with 12V batteries. Always check the voltage before installing.
- Never install the product in places exposed to dust, humidity and water. Pay attention to install it far from fuel tank, fuel lines, heat sources and other parts of vehicle.
- Be sure to install protection fuse or a circuit breaker near to battery. Follow the ampere rating as indicated here in this manual. Use of improper fuse or circuit breaker could result in overheat, smoke, damage to product, injury or burns.
- Avoid running wires over or through sharp edges. Use rubber or plastic grommets to protect any wires routed through car's body.
- Automotive sound systems may produce high sound pressure levels. Avoid continuous exposure to levels over 85dB to prevent permanent hearing loss.

## Key recommendations

The wire gauge for power supply connections is 1,5mm<sup>2</sup> (15 AWG) for positive and negative wires, and 0,50mm<sup>2</sup> (20 AWG) for remote signal wire.

For protection against overload, install a fuse on positive wire, close to battery terminal (1A). See page 12.

- 1 -  Power supply negative: Connect to negative pole of battery.
- 2 - Remote signal input: Connect to remote signal output from head unit.
- 3 - Remote output: For connection in amplifiers
- 4 -  Power supply positive: Connect to positive pole (12V) of battery.

## Safety

As you read this manual, pay attention to the safety symbols.



This symbol with “**CAUTION**” is intended to alert the user to the presence of important instructions. Failure to heed the instructions will result in risk of injury to user or product damage.



Taramps reserves the right to modify the contents of this document at any time without prior notice and does not have the obligation to apply the changes in units which were previously produced.

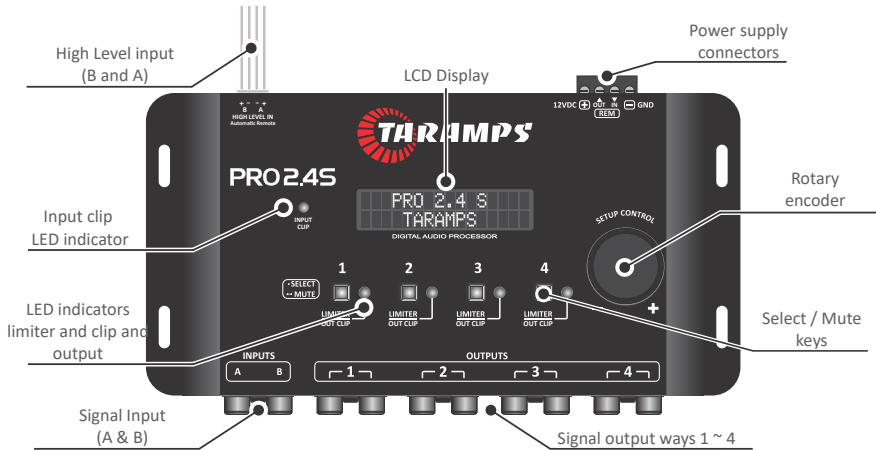

**RCA signals input:** Input for low level / high impedance (RCA) signals.

**WIRE High Level Input:** Input for high level / low impedance signals (from the speaker output of the players or multimedia center).

*It features function of triggering through the input signal, so it eliminates the use of the REMOTE IN wire from the power connector when using this input.*

**Note:** The system is designed for use in virtually all multimedia head units on the market. However, on some head units, you may not get the trigger effect due to the type of audio output circuit. In this case, use the REMOTE wire for triggering it normally.

**Input clip indicator LED:** It shows that the signal is reaching the maximum limit of the processor input, which causes signal distortion. If it comes on, reduce the volume of the signal source and readjust the system gains accordingly.

**Limiters / clip LEDs:** They have a dual function: They indicate that the signal from that output has reached the maximum level (when the limiter is off) or the actuation of the limiter (when the signal reaches the threshold defined in the limiter).

**Power connector:** See page 12.

## Screens & basic operation:



**INITIAL SETUP:** When turned on for the first time, the processor waits for the language to be set. Choose the desired language and confirm with a quick touch in the center of the encoder.

Turning the encoder knob (clockwise or counterclockwise), adjusts the master volume (Input volume).



## Output selection keys

Quick touch (Click) on the key of each output(1 to 4) It performs an adjustment of the individual gain in each output.

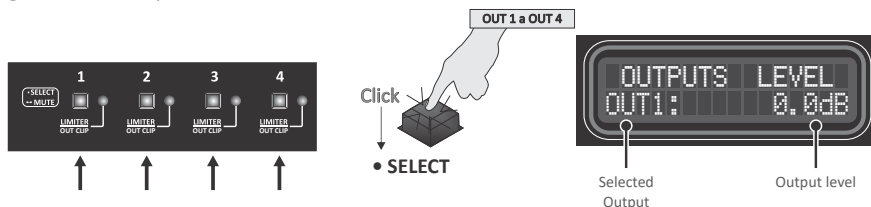

Individual mute: Press the output key (1 to 4) for 1 second until the key goes out. To unmute individual sound, press it again for 1 second.

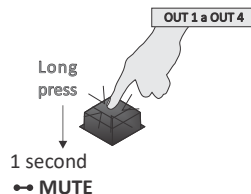

Quick click on the center of the encoder, to access the MAIN MENU and its functions.

Long touch (1 second) in the center of the encoder returns to the previous menu, until returning to the initial screen.

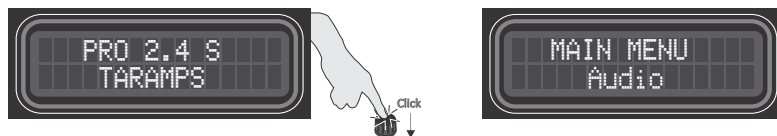

## Menu & parameters navigation

Use the encoder, turning left (decrement) or right (increment). Menu selection, option or parameter change can be done by pressing the center of the encoder.

**Note:** In any of the audio adjustment screens, the hotkeys for channels 1 to 4 allow you to check and adjust the parameters of each channel without leaving the desired option

**Tip:** To fine-tune a parameter or increment/decrement the number after the decimal point, rotate the encoder slowly. E.g., in the signal level (dB) adjustments, the increment will be 0.1dB when turning the encoder slowly, and 1dB when turning it more continuously and quickly.



# Menu structure & Description

ENGLISH

PT-BR	ENG	ESP
<b>MENU PRINCIPAL :</b>	<b>MAIN MENU :</b>	<b>MENU PRINCIPAL :</b>
1-Áudio	1-Audio	1-Audio
2-Gerador De Áudio	2-Audio Generator	2-Generador Audio
3-Idioma	3-Language	3-Idioma
4-Salva Config.	4-Save Config	4-Guardar Config
5-Carrega Config	5-Load Config	5-Cargar Config
6-Senha / Bloqueio	6-Password / Lock	6-Contraseña / Bloqueo
7-Presets EQ	7-EQ Presets	7-Preset EQ
8-Mensagem / Texto	8-Text / Message	8-Mensaje de Texto

Press the encoder button (center – long press) to back to Main Screen.

**1- Audio menu:** Adjusts and controls related to audio processing:

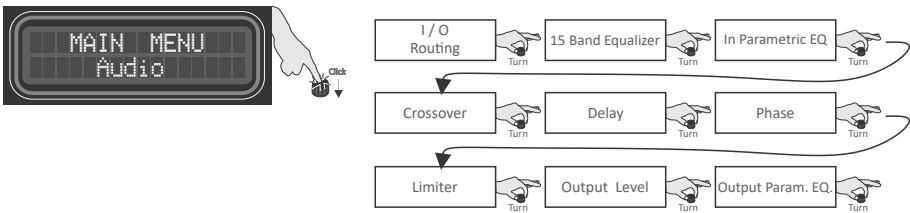

**I/O Routing:** Defines the internal connections between outputs and inputs. Available options: A, B or A+B (sum of the two inputs).

E.g.: setting the OUT 1 output to A, its signal will come from input A.



Use the OUTx keys to select the desired way

Turn the rotary encoder to select the input

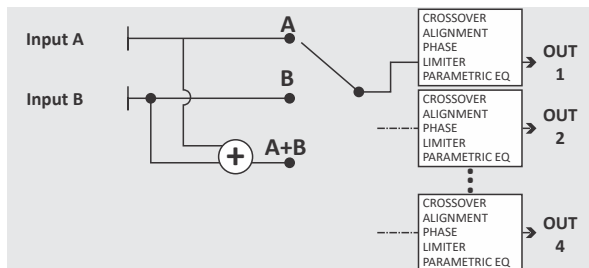

**-Band equalizer:** It has 15 bands of equalization, with attenuation /boost of up to 12dB, and center frequencies defined in the ISO standard (25 to 16KHz, 2/3 octave). Acts simultaneously on inputs A and B.

The Pro 2.4S has 12 preset equalizers, selectable in MAIN MENU > Presets EQ.

Click on the encoder center to select the desired parameter

Selected band      gain or attenuation

Rotate the encoder to change the selected parameter

**- Input parametric equalizer:** EQ with 1 band and adjustable parameters, acts simultaneously on inputs A and B.

**G** = Filter gain/attenuation (-12dB to +12dB)

**F** = Filter actuation center frequency, adjustable from 10Hz to 22KHz

**Q** = Filter width adjustment from 0.4 (widest) to 10.0 (narrowest)

Click on the encoder center to select the desired parameter

Gain or Attenuation

Central frequency      Width (Q)

Rotate the encoder to change the selected parameter

+12dB  
0dB  
-12dB

10Hz      22kHz

Q

G+ Gain  
G- Attenuation

F

**-Crossover:** Set the high pass (HPF) and low pass (LPF) filters of selected output way. The cutoff frequencies could be set from 10Hz to 22KHz, and are available some kinds of filters (Butterworth, Bessel, Linkwitz Riley) in different slopes (-6, -12, -18, -24, -36 e -48dB/Octave).

High Pass Frequency selection

Selected output

XOVER HPF OUT1  
f: 20 Hz OFF

Cut off Frequency

Low Pass Frequency selection

Selected output

XOVER LPF OUT1  
f: 20000 Hz OFF

Cut off Frequency

HPF

10Hz      22kHz

LPF

10Hz      22kHz

**FILTER TYPE / ATTENUATION:**

OFF: Off

LR12 Linkwitz - Riley c/ -12dB/octave

LR18 Linkwitz - Riley c/ -18dB/octave

LR24 Linkwitz - Riley c/ -24dB/octave

LR36 Linkwitz - Riley c/ -36dB/octave

LR48 Linkwitz - Riley c/ -48dB/octave

BT6 Butterworth c/ -6dB/octave

BT12 Butterworth c/ -12dB/octave

BT18 Butterworth c/ -18dB/octave

BT24 Butterworth c/ -24dB/octave

BT36 Butterworth c/ -36dB/octave

BT48 Butterworth c/ -48dB/octave

**Delay:** Set the delay to be applied to audio signal, for systems alignment. The position of transducer's voice coil should be taken in account in order to set the optimal delay value.

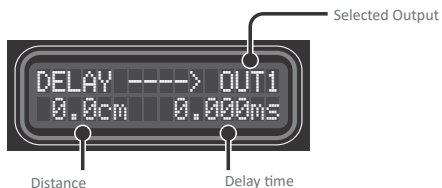

Rotate the rotary encoder to set the delay amount to be applied.

The voice coils of each transducers isn't aligned inside the acoustic box, so there is some delay that can degrade the perfect audio playing. The **Delay** feature apply different delay amount for each output way, in order to get the perfect audio alignment.

## How to set the delay parameter value (centimeter):

- 1 Set the reference coil (\*) farthest from the box panel (in our example, the reference was the center of the horn coil)
- 2 Measure the other channels and find the measurement. Set the closest measurement (in cm) for each channel.
- 3 Repeat the procedure for the other channels (the channel selection can be done through the keys of each channel).

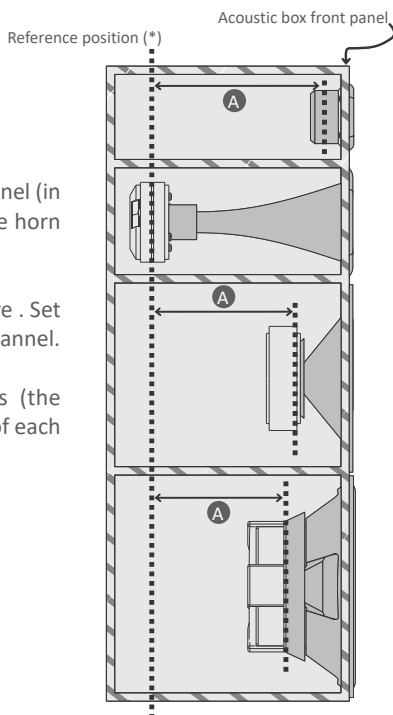

**-Phase:** Allows inverting the phase of the channel output signal, selecting option [180]. Select the channel using the OUT1 to OUT4 selection keys and select the desired phase by turning the encoder.

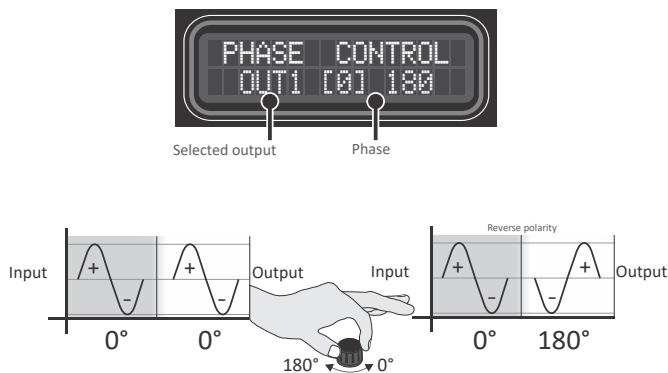

**-Limiter:** Configures the limiter, which acts as a limiter on the maximum signal level of the processor output, not to exceed the power limit defined for each channel.

Modes: **MAN** = Manual Attack and Release adjustment; **AUT**: Sets the Attack and Release parameters automatically, according to the frequency cutoff (**HPF**).

Limiter parameters:

**T** = Threshold, – Point from which the limiter starts to act (indicated by the lighting of the RED LED on each channel). To turn off the limiter, turn the encoder clockwise until [OFF] that appears at the threshold value.

**A** = Attack, – Time the limiter waits before reducing gain after the signal exceeds the threshold.

**R** = Release, – Time it takes the limiter to return to its original gain after the signal drops below the threshold.

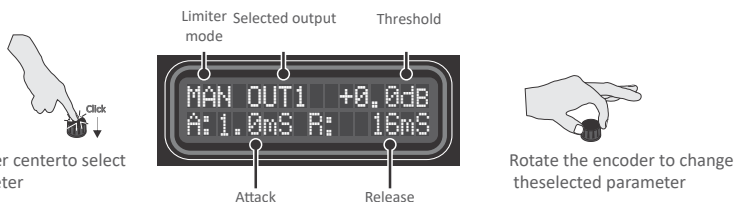
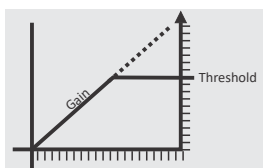

Click on the encoder center to select the desired parameter

Rotate the encoder to change the selected parameter

**-Output level:** Set the level for each output way. Allow apply up to +15dB gain or -45dB attenuation.

Select the desired way using the OUTx (1-4) Keys.

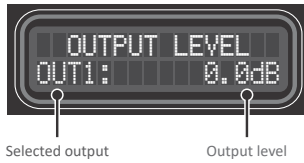

*Note: This function can be accessed outside the menu by simply pressing the corresponding output key when in the main screen.*

**-Output parametric EQ.:** EQ with 1 band and adjustable parameters for:

**G** = Filter gain/attenuation (-12dB to +12dB)

**F** = Filter actuation central frequency, adjustable from 10Hz to 22KHz

**Q** = Filter width adjustment from 0.4 (widest) to 10.0 (narrowest)

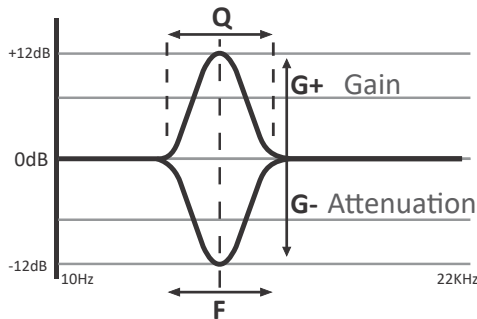
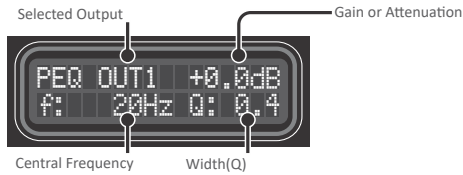



-) **Audio Generator:** Sine wave generator, with frequency and variable amplitude. With 4 modes:

- **Fixed Frequency:** Sine generator with frequency (10Hz to 22KHz) and amplitude (-60dB to 0dB) adjustments. Note that when activating the generator, the signal is sent to all outputs and it is possible to adjust the other functions and parameters in real time, since the generator remains active and defined as a signal source when in the ON position, even when accessing another function. .

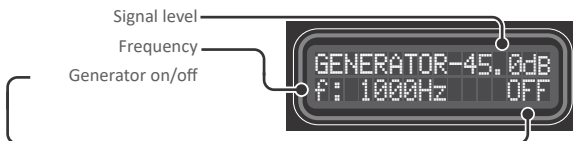

--**Sweep (Slow / Medium / Fast):** It performs a signal sweep, with the initial and final frequency defined by the user, which remains in a continuous cycle (repeating) until the generator is turned OFF. There are 3 sweep speeds available.

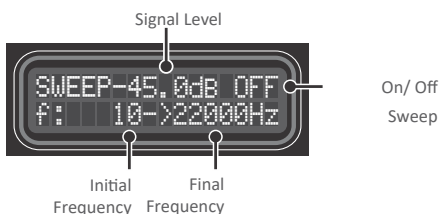

3-) **Language:** Choose the desired language (Portuguese, English or Spanish)



4-) **Save config:** Allows you to choose the memory location and assign a convenient name to these settings. Selecting which memory location, click on the encoder center to switch to the text. Rotate the encoder to select the desired letter, click on the center of the encoder to move to the next character. To erase, rotate the encoder until “<” + quick touch on the center of the encoder. To finish editing and save the memory name, place the cursor after the last character + long press on the center of the encoder and confirm “YES”.

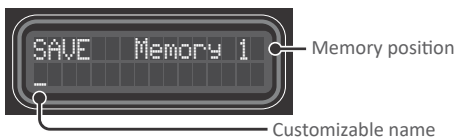



**5-) Load config:** Load a previously saved configuration or the factory default setting. Rotate the encoder to select the desired memory, click on the center of the encoder to select and then confirm. Important: when you select the FACTORY SETTINGS option, the previously saved settings will be lost.



**6-) Password / lock:** Allows you to lock the processor using a password (the default password is 1234) or change the password to a personalized one, with 4 digits.

NOTE: When locking the processor, a padlock icon will appear in the upper right corner of the screen. A password will be required to access the settings.

To reset the processor to factory settings without accessing the menu (e.g. due to lost/forgotten password), just turn on the processor while keeping the keys of ways 1 and 2 and the center of the encoder pressed simultaneously.

This will erase the contents of user settings memories and reset the product to initial setup.

**7-) Presets EQ:** The Pro 2.4S has 12 preset equalizers. Select the music style and press the encoder center to apply the equalization curve:

- FLAT
- LOUDNESS
- BASS BOOST
- MID-BASS BOOST
- TREBLE BOOST
- POWERFUL
- ELECTRONIC
- ROCK STYLE
- HIP-HOP STYLE
- POP MUSIC
- VOCAL
- COMPETITION

**8-) Text message:** Defines a text of up to 15 alphanumeric characters to be displayed as screen saver animation. Enable the function by selecting ON and with a quick touch on the center of the encoder, and go to text editing (blinking cursor). Rotate the encoder to select the desired letter, click the center of the encoder to move to the next character. To erase, turn the encoder until “<” + quick touch on the center of the encoder. To finish editing and save the text, place the cursor after the last character + long press in the center of the encoder. After about 3 seconds of no activity on the main screen, the text will be displayed as an animation on the screen.

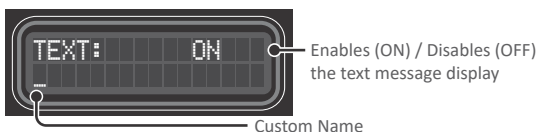

# Connecting Processor Inputs and Outputs

ENGLISH

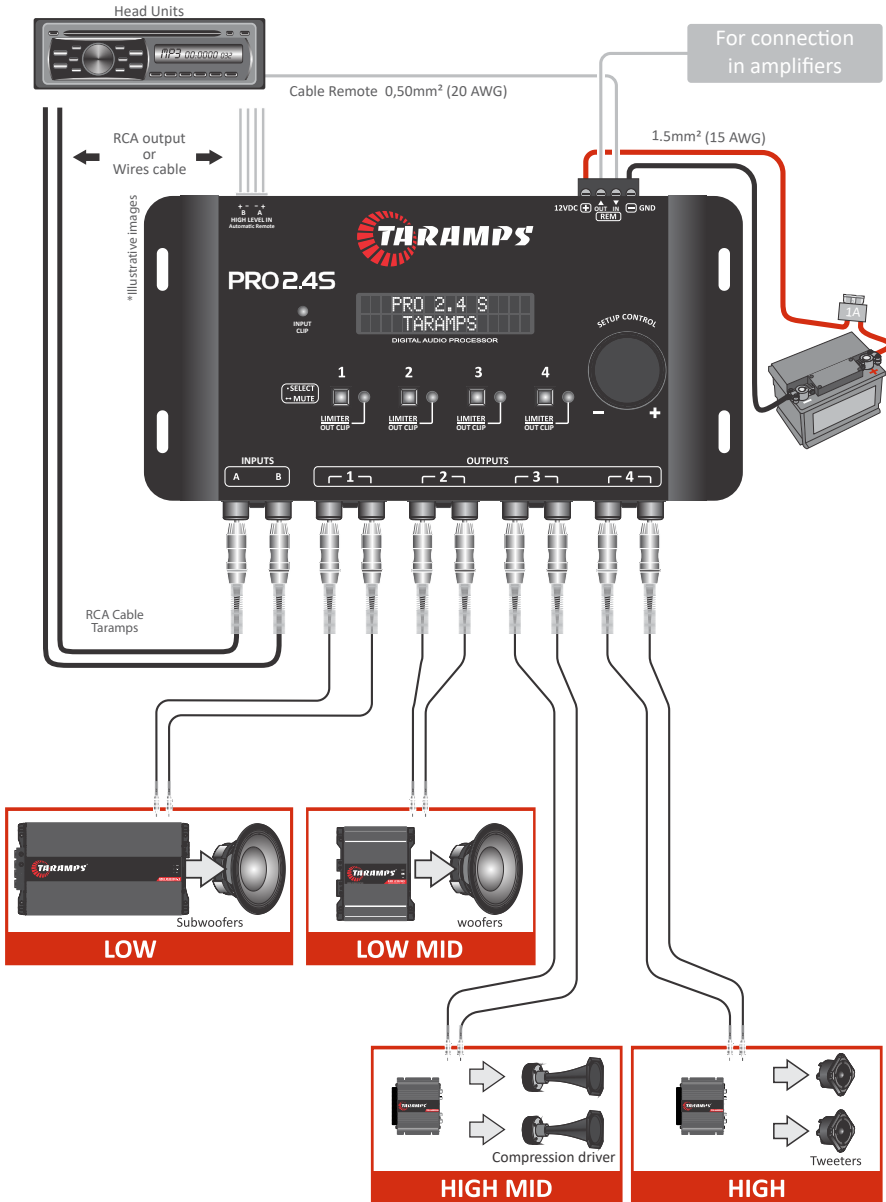

Check power polarity and recommended gauge. it is recommended to install a 1 Ampere fuse on the positive supply terminal.

# Technical features

## Processing

Resolution.....24bits  
Sampling rate.....48KHz

## Inputs and Outputs:

Number of input channels.....2  
Number of output channels.....4  
Input/output routing:..... A, B, A+B  
General gain adjustment:.....-80 a 0dB  
Output gain adjustment:.....-45 a +15dB  
Input impedance (RCA):.....10K ohms  
Input impedance (high level):.....50 ohms  
Output impedance:.....47 ohms  
Maximum input level (RCA):..... 5,9Vpp (2,1V RMS)  
Maximum input level (High level):.....28Vpp (10V RMS)  
Maximum output level:..... 5,9Vpp (2,1V RMS)  
Frequency response (-1dB).....10Hz a 22KHz  
Total Harmonic Distortion.....0,01%  
Signal / Noise Ratio:.....>90dB  
Crosstalk (separation between channels).....>80dB

## Input graphic equalizer, 15 bands, 2/3 octave and 12 presets:

Frequencies:.....25,40,63,100,160,250,400,630,1K,1.6K,  
2.5K,4K,6.3K,10K,16KHz  
Attenuation / Gain:.....-12dB to+12dB

## Input Parametric EQ:

Central frequency:.....variable from 10Hz to 22KHz  
Attenuation / Gain:.....-12dB a +12dB  
Q factor adjustment :.....0,4 a 10

## Crossover (HPF e LPF):

Cutoff frequency: ..... variable from 10Hz to 22KHz  
Linkwitz Riley Filters..... -12,-18,-24,-36,-48dB/octave  
Butterworth Filters..... -6,-12,-18,-24,-36,-48dB/octave

Alignment (Delay):.....8,0mS (272cm)

Phase:.....0 / 180°

## Adjustable Limiter:

Threshold:.....-24 to 0dB  
Attack: .....0.1mS to 100mS  
Release: .....1mS to 1600mS

## Output parametric EQ:

Central Frequency: .....variable from 10Hz to 22KHz  
Attenuation / Gain: .....-12dB to +12dB  
Q Factor Adjustment.....0.4 to 10

**MUTE** Function.....Individual at each output

## Audio generator (Sine waveform)

Frequency range.....Variable from 10Hz to 22KHz  
Gain:.....-60 to 0dB  
Modes:.....Fixed Frequency / 3 speed sweep

**Languages:** .....Portuguese, English and Spanish

**Setting memory positions:** .....Factory default + 3 assignable positions

**Screensaver function:** .....Text up to 15 characters

**Access protection:** ..... 4 password digits (customizable)

Supply Voltage: .....10 to 16VDC

Nominal consumption (12.6V): .....0.20A

Dimensions (WxHxD):.....198 x 37 x 113mm (7.80" x 1.46" x 4.45)

Weight:.....0.45Kg (0.99lb)



+55 18 3266-4050

Fabricado por / Manufactured by:  
TARAMPS ELECTRONICS LTDA  
CNPJ / TAX ID: 11.273.485/0001-03  
R. João Silvério, 121 • Res. Manoel Martins  
Alfredo Marcondes - SP  
Indústria Brasileira - Made in Brazil  
[www.taramps.com.br](http://www.taramps.com.br)