



# [HOONIGAN]



# Reflex<sup>14R</sup> ON ROAD READY-TO-RUN

1:14 SCALE 4WD ON ROAD READY-TO-RUN

# HOONICORN

#20178 REFLEX 14R HOONICORN



1:14 Scale 4WD Electric On Road RTR Manual



CHAMPIONS *by* DESIGN  
[AssociatedElectrics.com](http://AssociatedElectrics.com)

# TEAM ASSOCIATED

## :: Introduction

Thank you for purchasing this Team Associated product. This assembly manual contains instructions and tips for building and maintaining your new vehicle. Please take a moment to read through the manual and familiarize yourself with the steps. We are continually changing and improving our designs; therefore, actual parts may appear slightly different than the illustrations. New parts will be noted on supplementary sheets located in the appropriate parts bags. Check each bag for these sheets before you start to build.

## :: RC14R RTR Features

- Reflex 14R with licensed 1965 Ford Mustang Hoonigan Hoonicorn and officially licensed American Racing VF503 Wheels
- Injection molded brake calipers and rotors with 12mm hex
- 2.4GHz 2-channel radio system
- Reedy brushed speed control and 3-pole brushed motor
- High-Torque Digital Servo with spring-style servo saver
- Molded front universals and rear dog bones
- Sealed front and rear gear differentials
- Center spool with 58T spur (70T included) and protective cover
- Bushings with Oilite® coating
- Molded one-piece tie rods and steering links
- Adjustable body post height locations
- Molded front and rear shock towers with adjustable shock positions
- Fluid damped coilover shock absorbers
- Molded tub chassis with covered center driveshaft
- Adjustable battery tray
- Aluminum center driveshaft
- Serrated wheel screw with 2.0mm hex and 5.5mm nut drive
- Foam front bumper

## :: Table of Contents

1..... Cover	4 - 5..... Quick Start Guide
2..... Introduction	6 - 17..... Steps 1 - 33
3..... 1:1 Hardware "Fold Out"	18..... Back Cover

## :: Notes



**There is a 1:1 hardware foldout page in the front of the manual. To check the size of a part, line up your hardware with the correct drawing until you find the exact size. Each part in the foldout has a number assigned to it for ordering replacement parts.**



**This symbol indicates a special note or instruction in the manual.**

## :: Additional

Your new Reflex 14R RTR comes assembled. The following items are needed for completion

- 6-cell NiMh or 2 LiPo battery
  - Suitable battery charger
  - (4) AA batteries
- Tools included: • Multi-wrench

## :: Other Helpful Items

- Silicone Shock Fluid
- Reamer / Hole Punch (#1499)
- Wire Cutters
- Needle Nose Pliers
- FT Dual Turnbuckle Wrench (#1114)
- Silicone Diff Fluid
- Shock Pliers (#1681)
- Soldering Iron
- Hobby Knife
- FT Universal Tire Balancer (#1498)
- Body Scissors (AE Part # 1737)
- FT Hex/Nut Wrenches (AE Part # 1519)
- Green Slime shock lube (AE Part # 1105)
- Calipers or a Precision Ruler

**Associated Electrics, Inc.**  
21062 Bake Parkway  
Lake Forest, CA 92630



**Customer Service**  
Tel: 949.544.7500  
Fax: 949.544.7501

**:: Hardware - 1:1 Scale View**

**Cap Head (shcs)**



**2.5x12mm (8691)**

**Flat Head (fhcs)**



**2.5x10mm (21546)**

**Bushings**



**4x7x2.5mm (21512)**



**4x8x3mm (21512)**



**8x12x3.5mm (21512)**

**Button Head (bhcs)**



**2.5x3mm (89201)**



**2.5x6mm (31520)**



**3x6mm (31531)**

**Flat Head (fhst)**



**2x8mm (21546)**



**2.6x8mm (21546)**



**2.6x10mm (21546)**

**Button Head (bhst)**



**2.5x12mm (21582)**



**2.6x6mm (21546)**



**2.6x8mm (21546)**



**2.6x10mm (21546)**

**Set Screws**



**3x2.5mm (31500)**



**3x3mm (25225)**



**3x8mm (4670)**

**Shims and Washers**



**2.7x6.7x0.5mm (21546)**



**4x8x0.5mm (21516)**

**Pin**



**1.5x3.8 (21516)**

**Nuts (lock/plain)**



**M2.5 Locknut (89215, 21546)**

**Notes:**

## :: Quick Start Guide

### Battery Charging Steps and Safety:

Remove the battery from the vehicle before charging.  
Place battery on a fire resistant surface.  
Avoid any contact with water or other liquids.  
Be sure to select the correct charging mode for the type of battery you are charging.

**ALWAYS** use a compatible charger for charging your batteries.

**Caution: Never leave the battery unattended while charging. Always disconnect the charger from the power source when finished charging.**

**Caution: Always disconnect the battery when you are finished driving the vehicle.**



**Peak Detection  
Quick Charger**

## :: Quick Start Guide - (cont.)

### Battery Installation:

1. Install the battery with the battery wires directed towards the rear of the vehicle.
2. Secure the battery strap using two body clips.

**1**

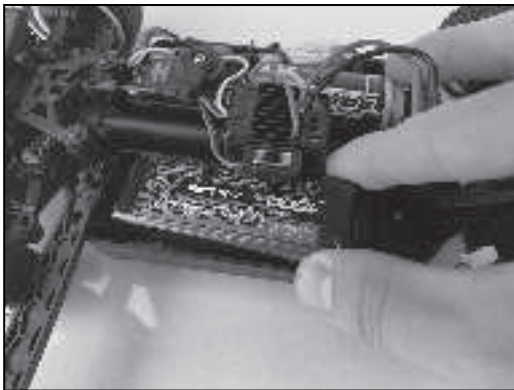

**2**

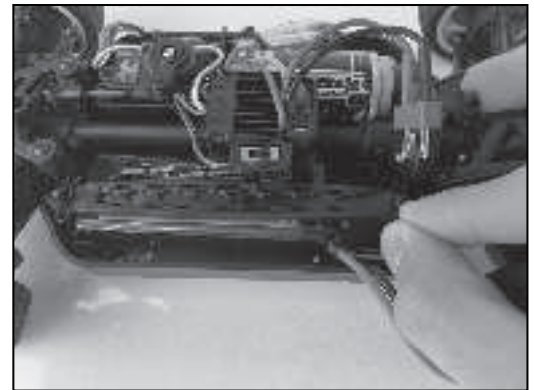

## :: Quick Start Guide - (cont.)

### Battery Notes and Tip:

Connect the battery as shown.

**Disconnect the battery when not in use!**

**LiPo:** LiPo batteries (lithium polymer) are high current rechargeable batteries. LiPo batteries offer extended run time and peak performance over NiMH batteries. They require a peak detection charger designed specifically for LiPo batteries. These batteries require special care and handling. LiPo batteries are recommended for advanced users only!  
**ALWAYS** charge a LiPo battery in LiPo mode.

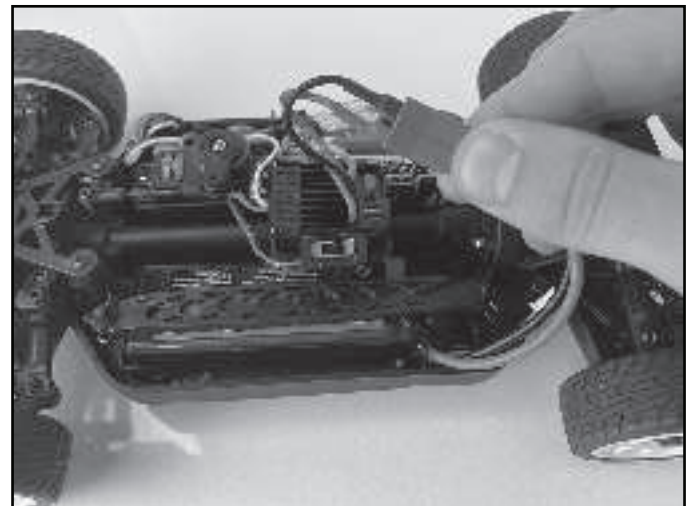

## :: Quick Start Guide - (cont.)

### Radio System Tuning and Controls:

**RULE:** Transmitter on First/Vehicle on Second,  
Vehicle off First/ Transmitter off Last!

- 1) Slide the battery cover to remove cover.
- 2) Install alkaline or rechargeable AA size batteries into the battery holder.
- 3) Slide the battery cover back into place making sure it is completely closed and secure.
- 4) Turn the power ON. If the power indicator LED fails to light, check the batteries for insufficient contact or incorrect polarity.



## :: Quick Start Guide - (cont.)

### Radio System Tuning and Controls:

**DO NOT** hold the trigger when turning on the radio.

If using optional battery for transmitter, be sure to plug it in correctly. Plugging in a battery backwards can cause damage.

Refer to Radio owners manual for more in-depth instructions on radio operation and functions.

**Adjust steering trim with this knob so wheels point straight.**

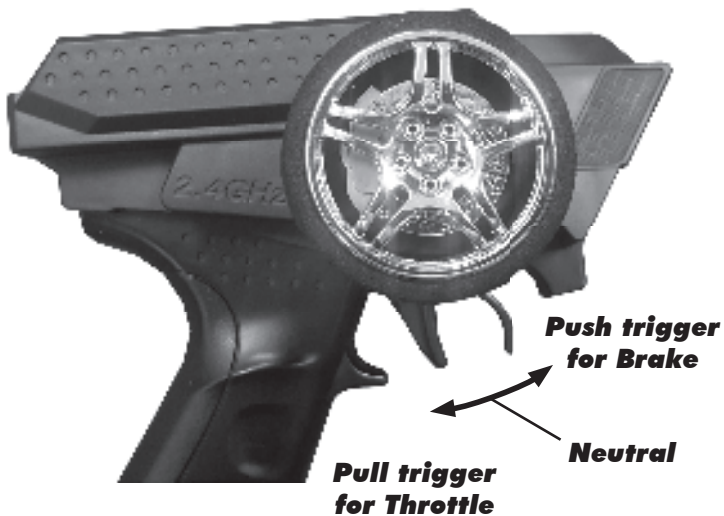

**Throttle set to Neutral!**

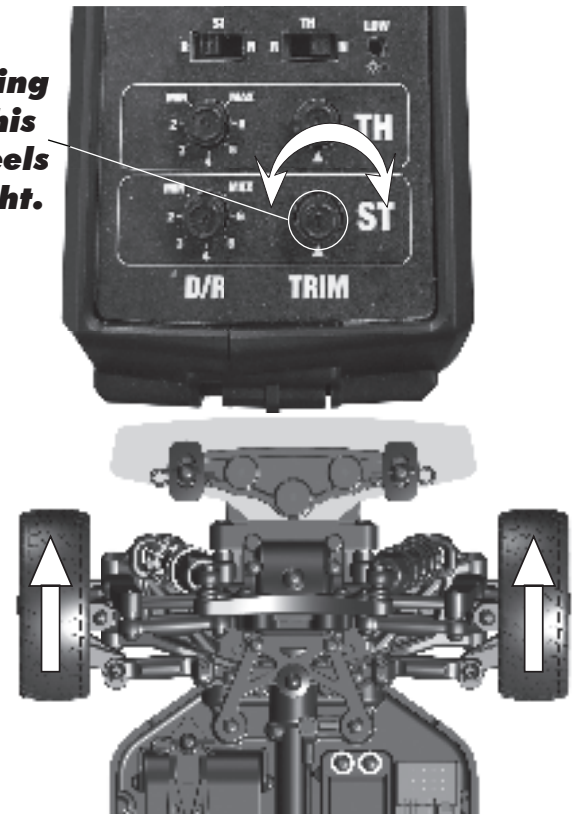

**Install body and body clips.  
Ready to go!**

**:: Step 1**

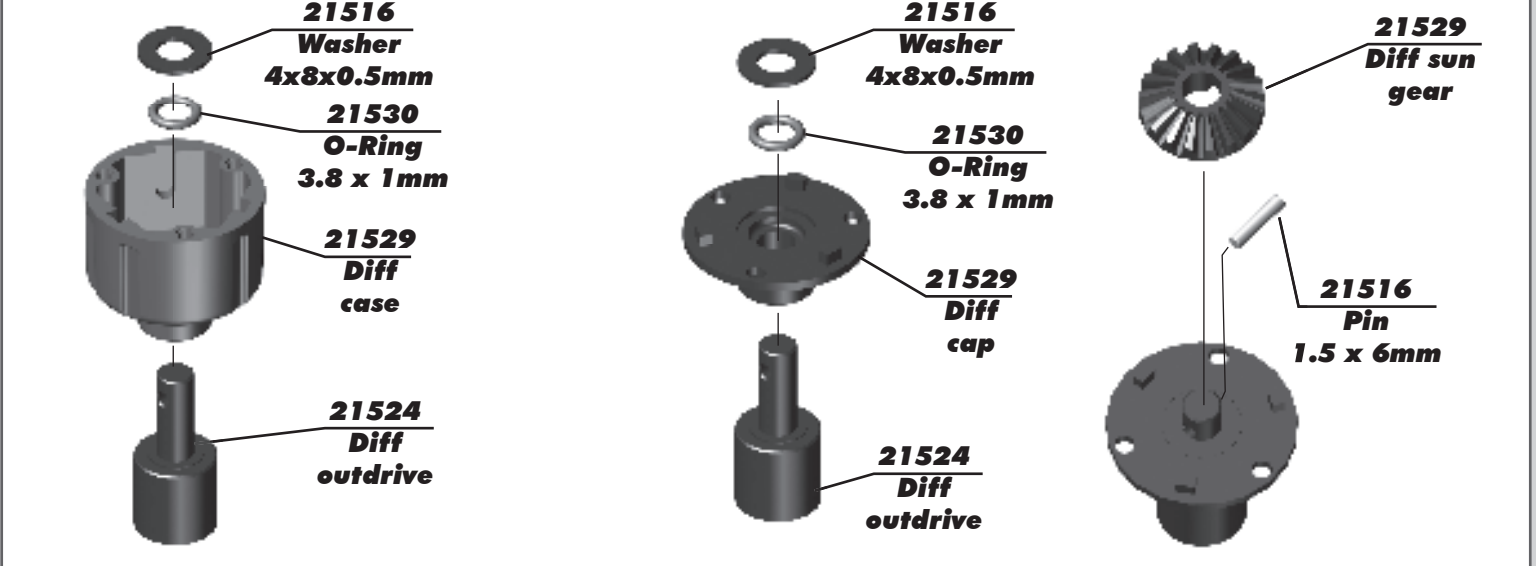

**:: Step 2**

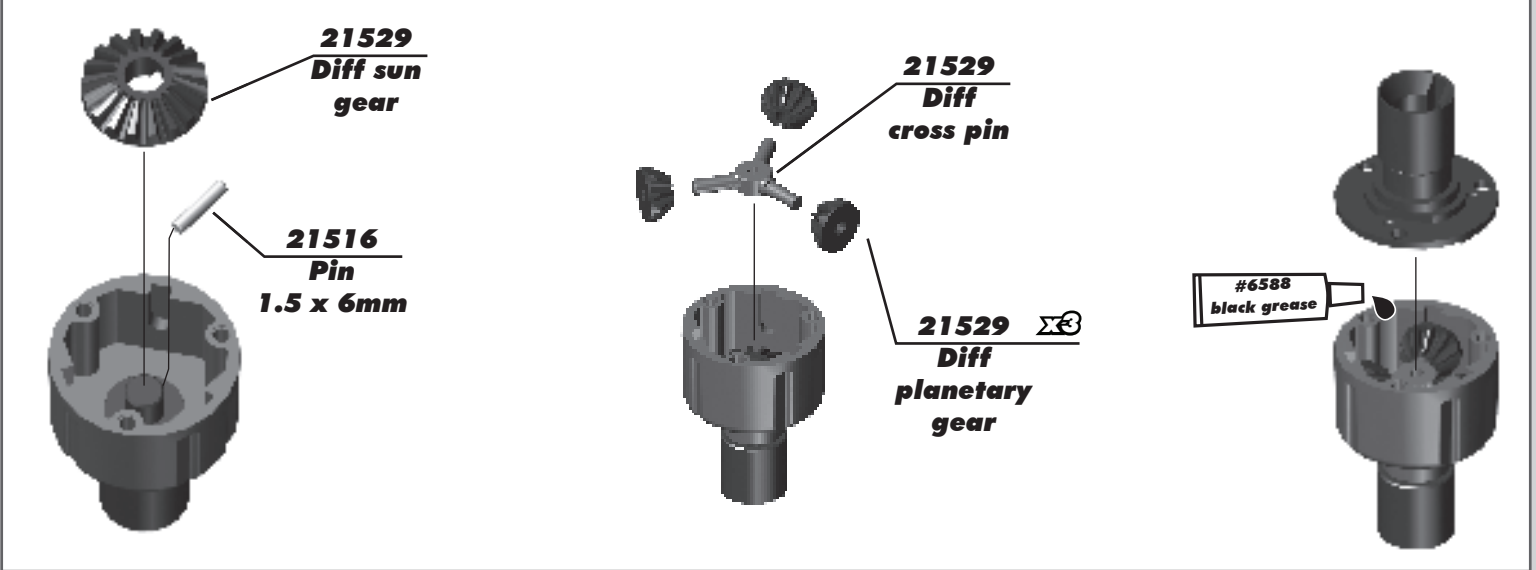

**:: Step 3**

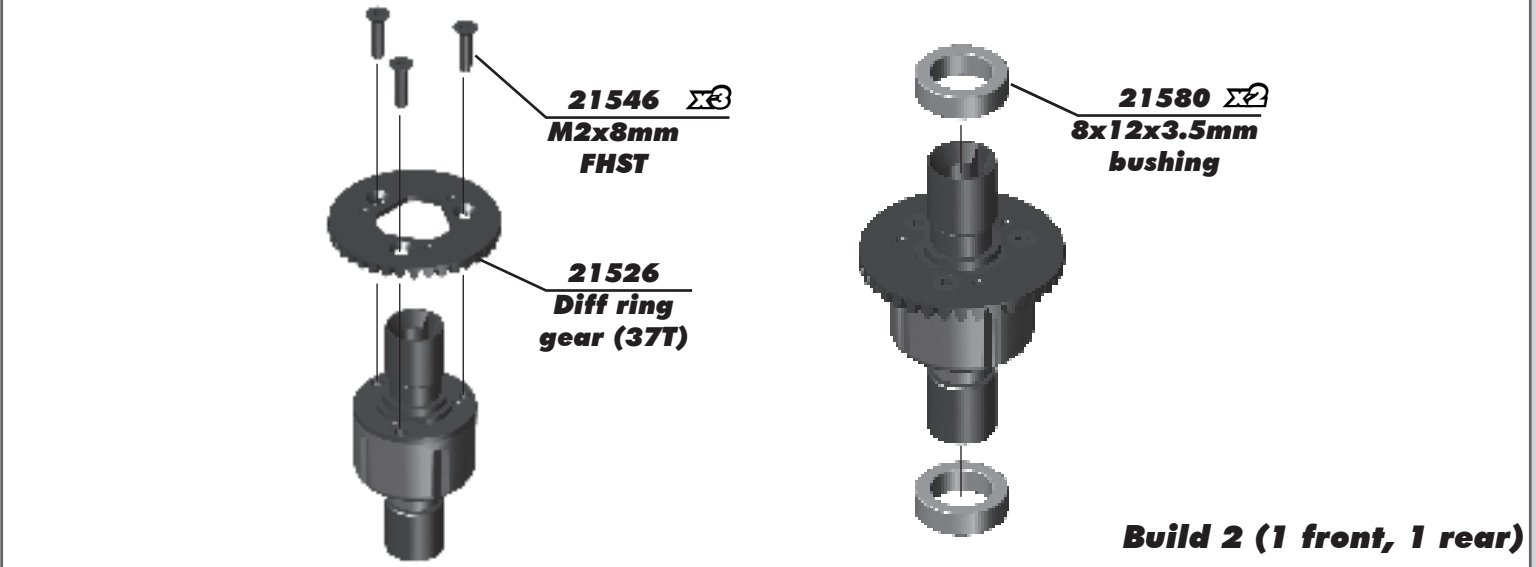

## :: Step 4

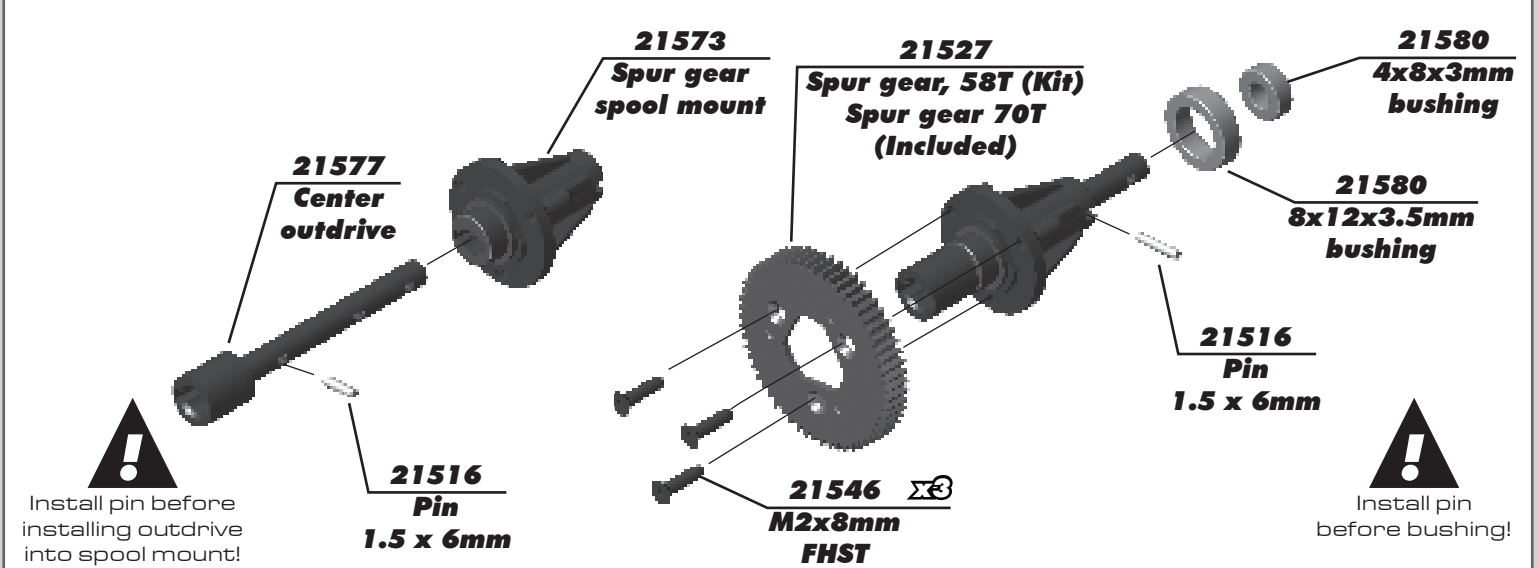

## :: Step 5

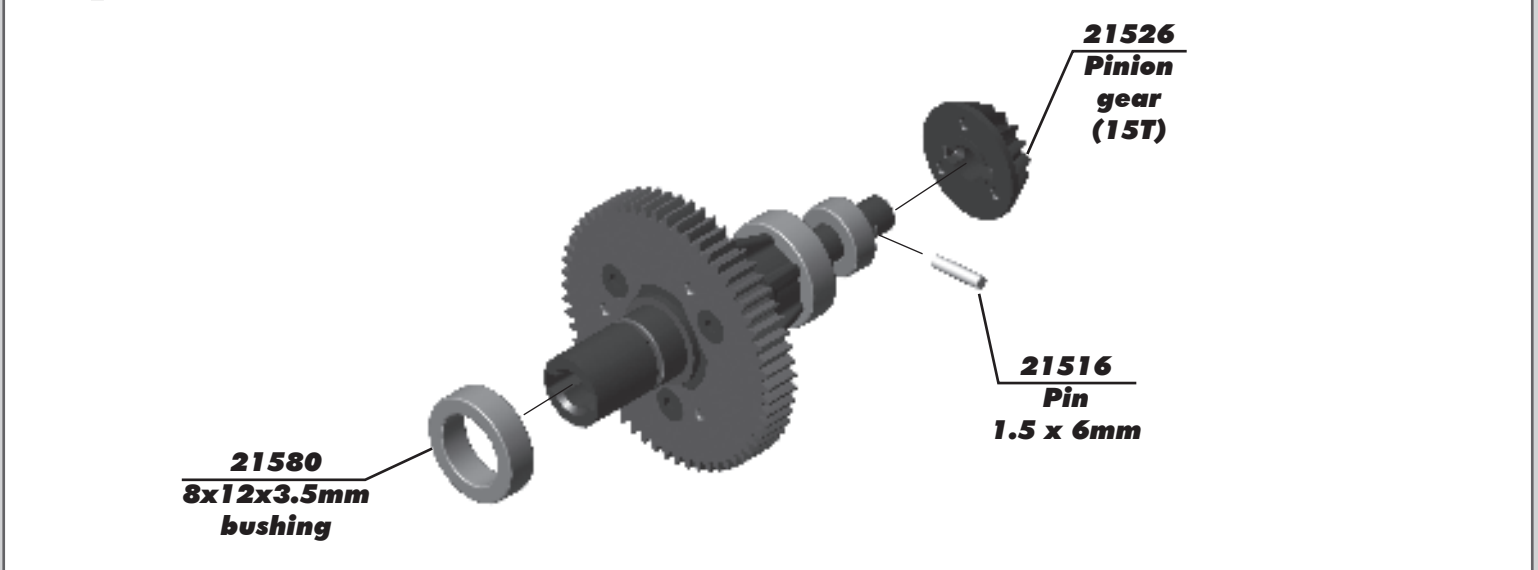

## :: Step 6

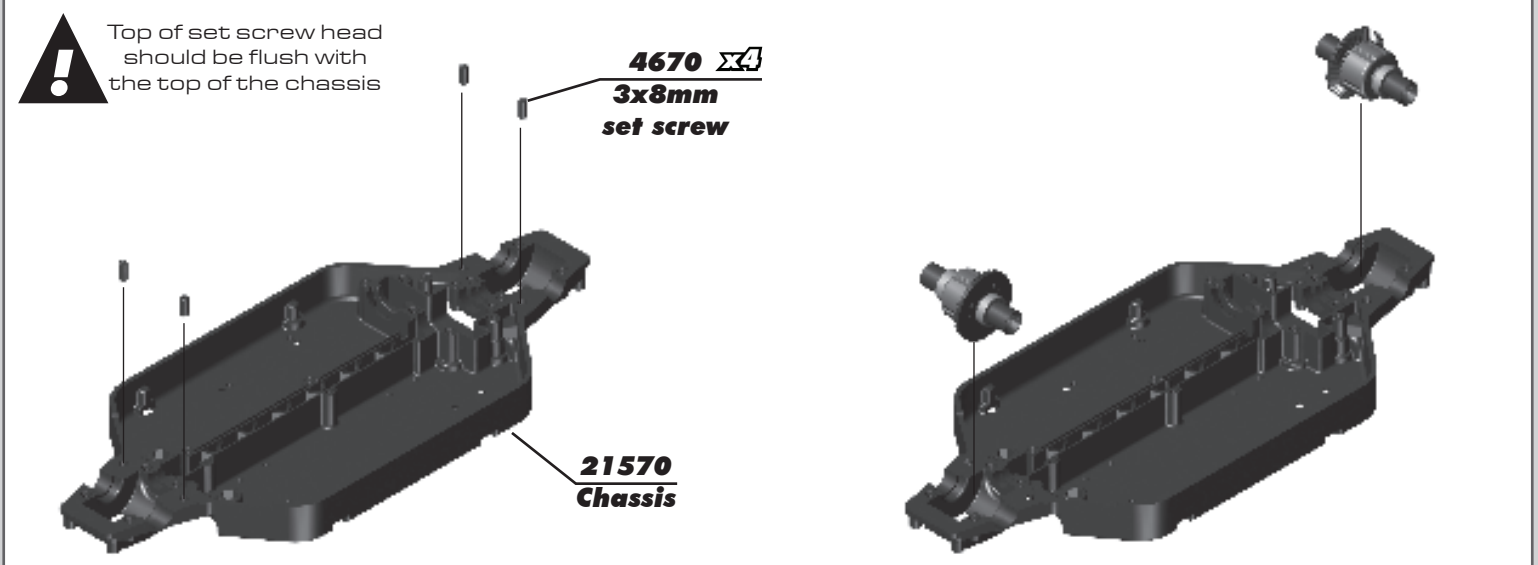

**:: Step 7**

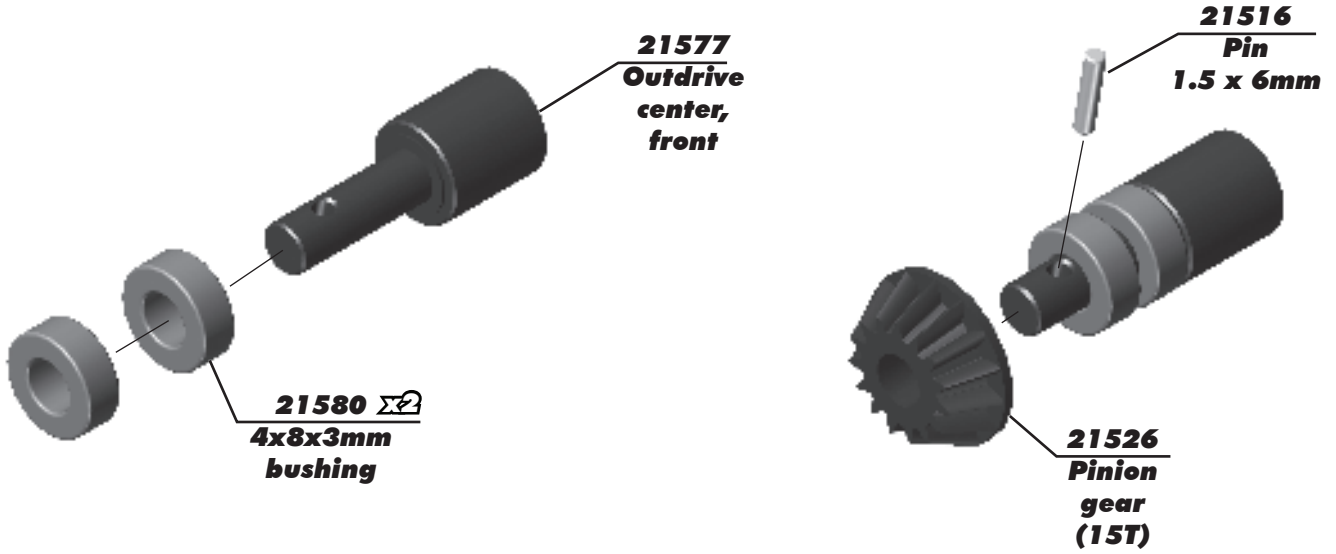

**:: Step 8**

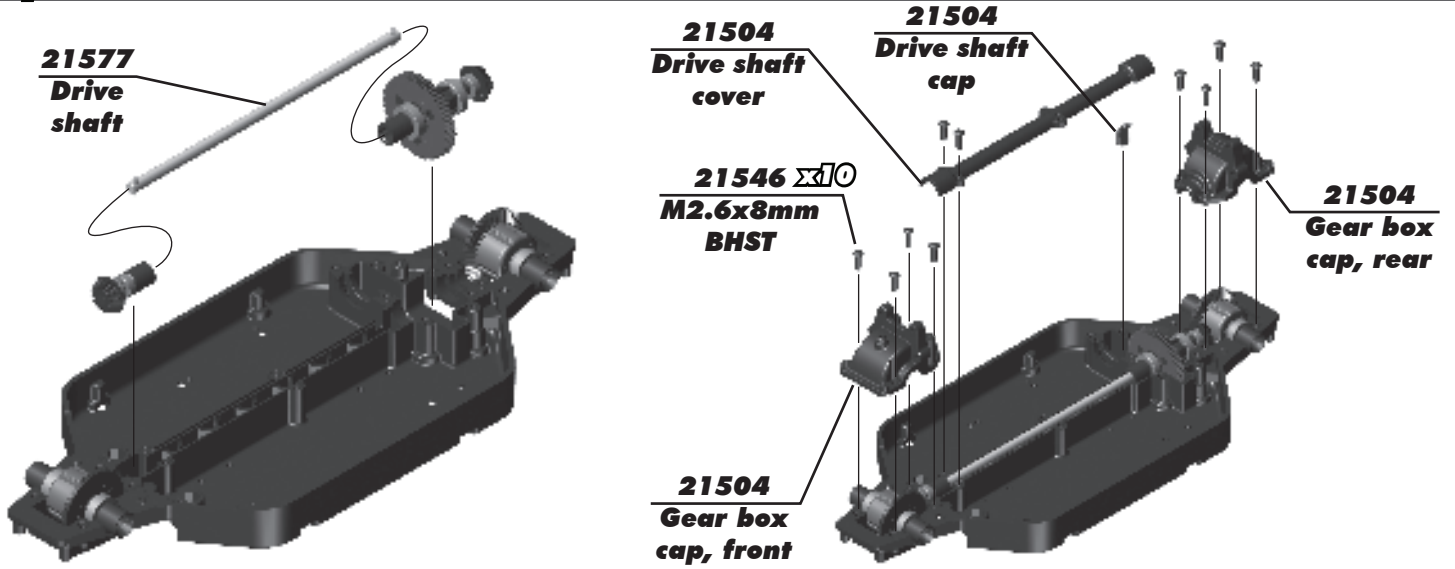

**:: Step 9**

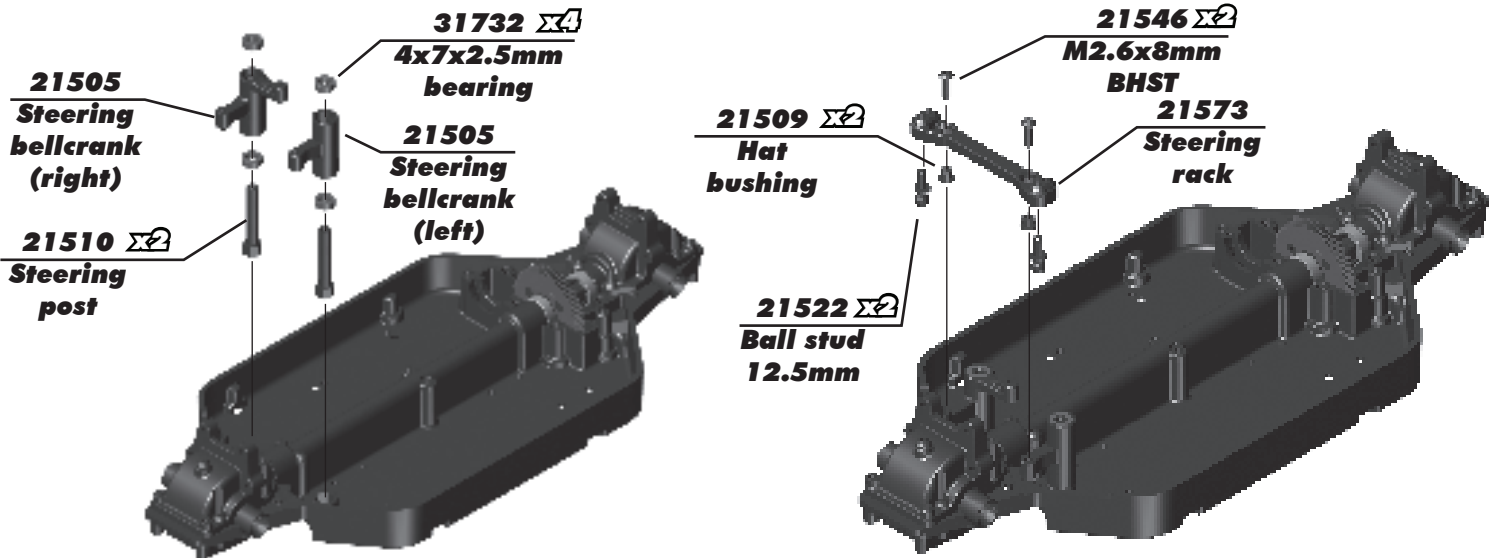

**:: Step 10**

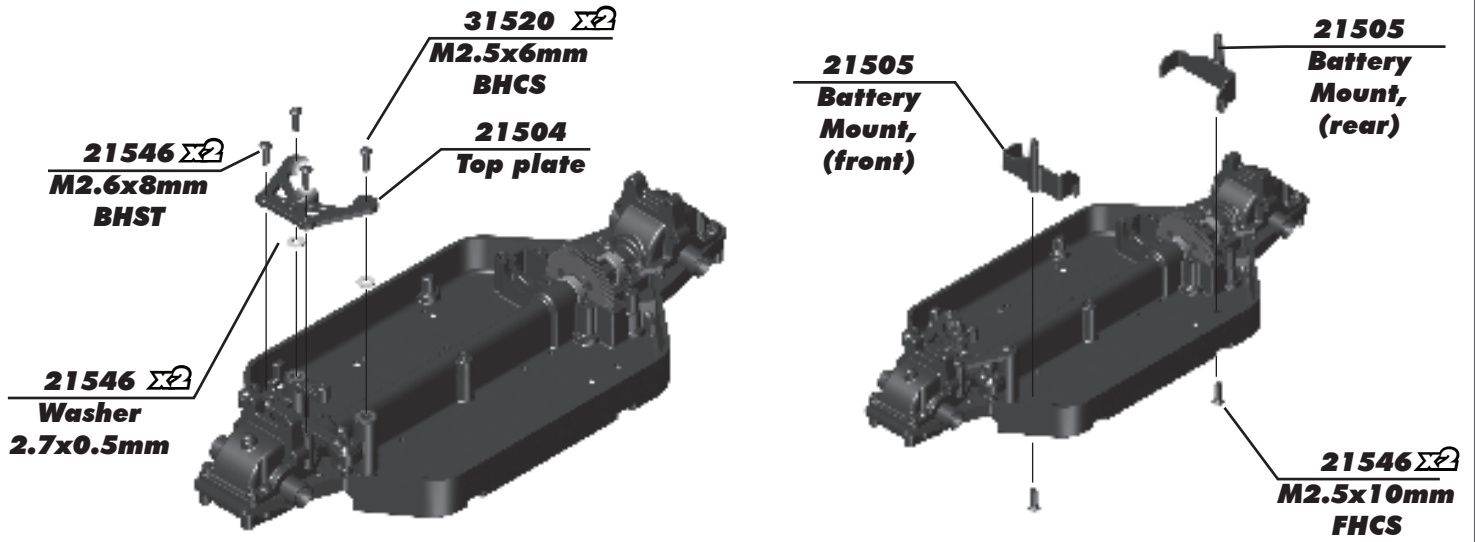

**:: Step 11**

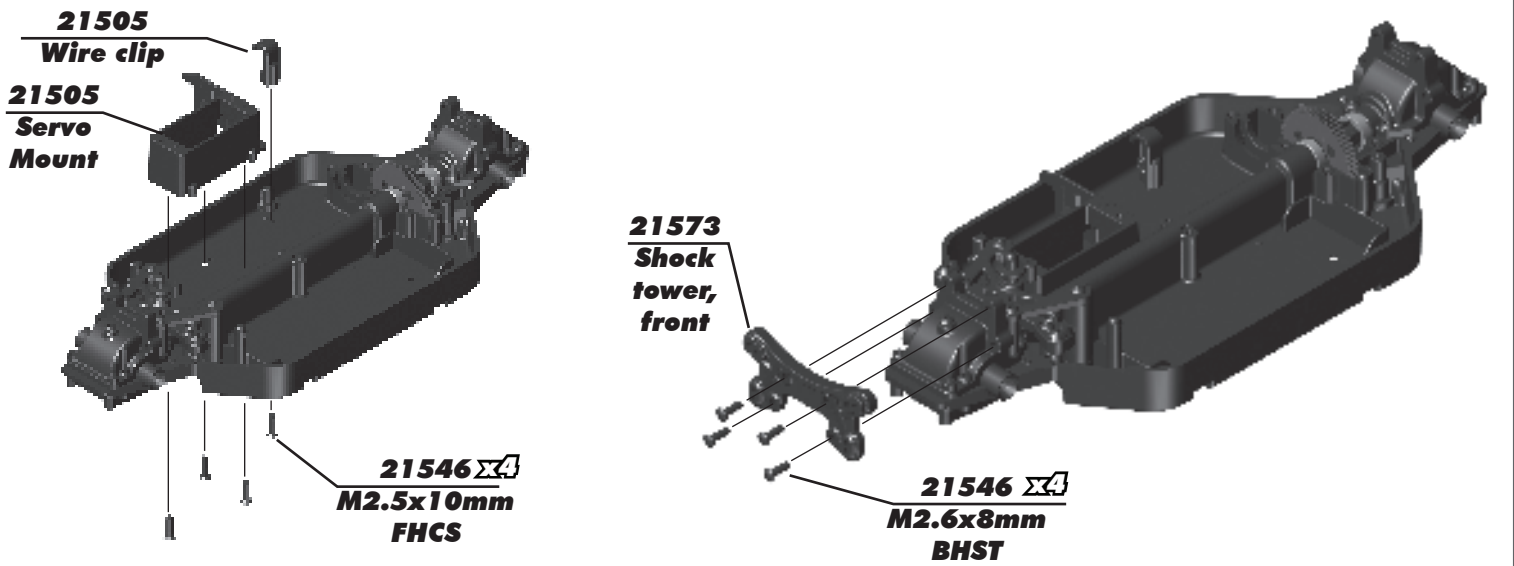

**:: Step 12**

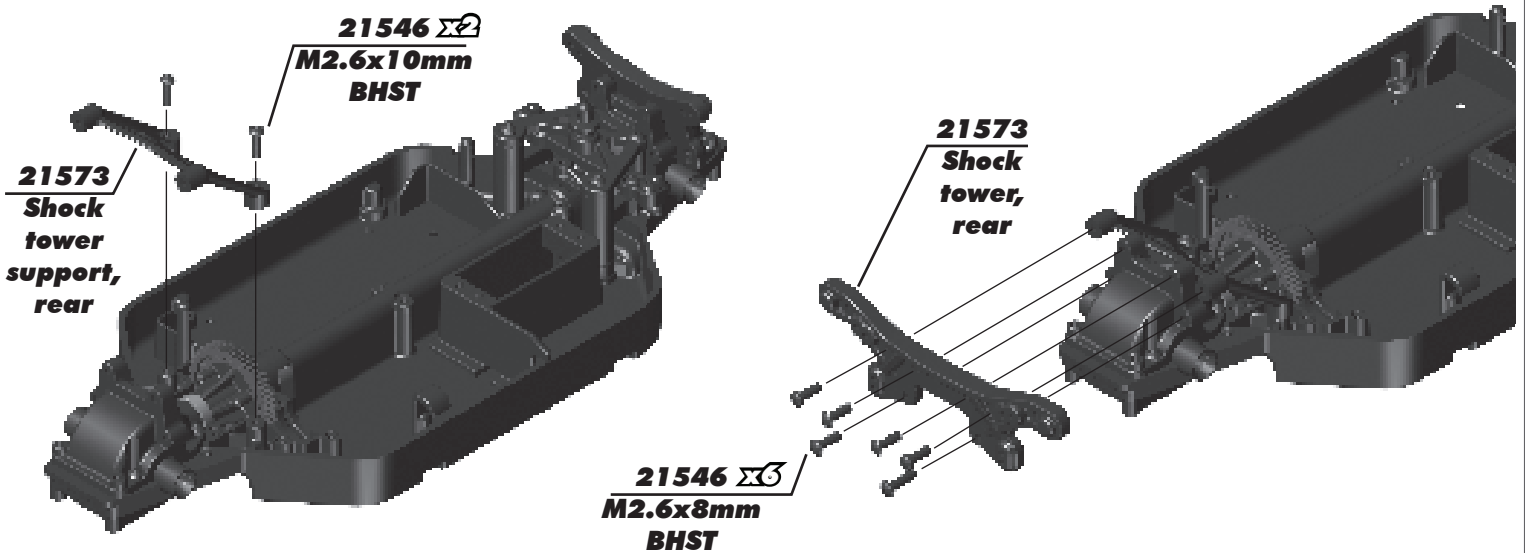

**:: Step 13**

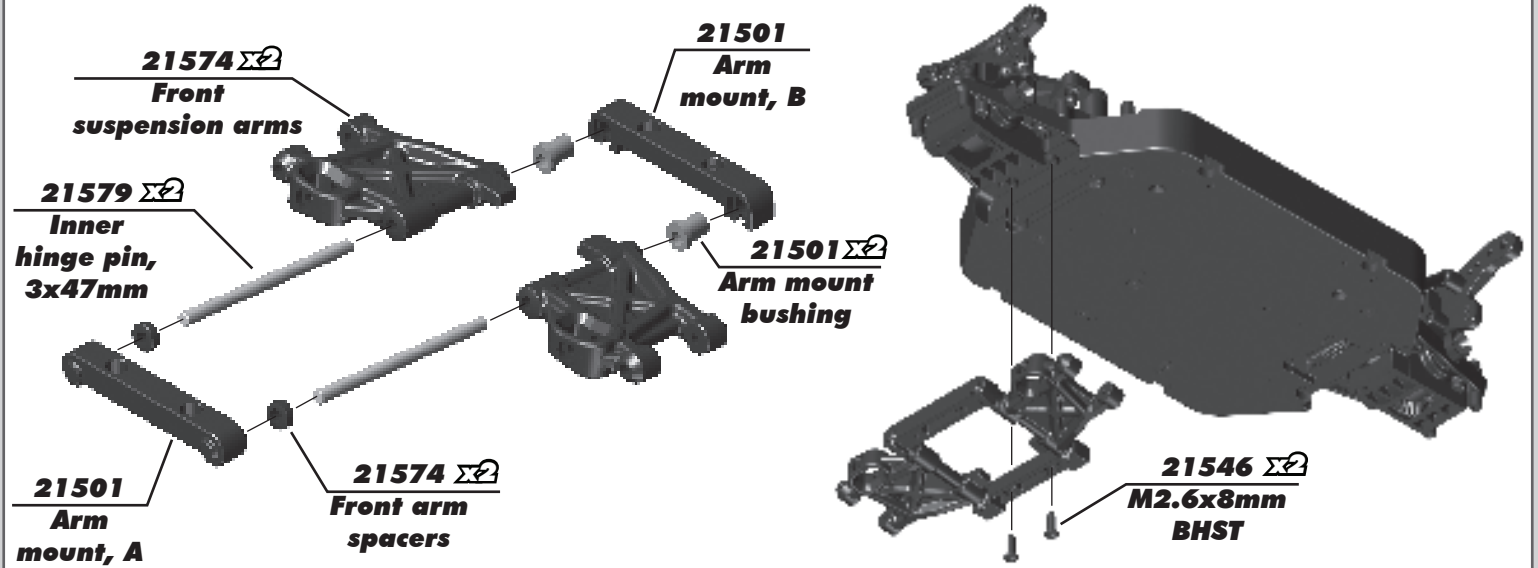

**:: Step 14**

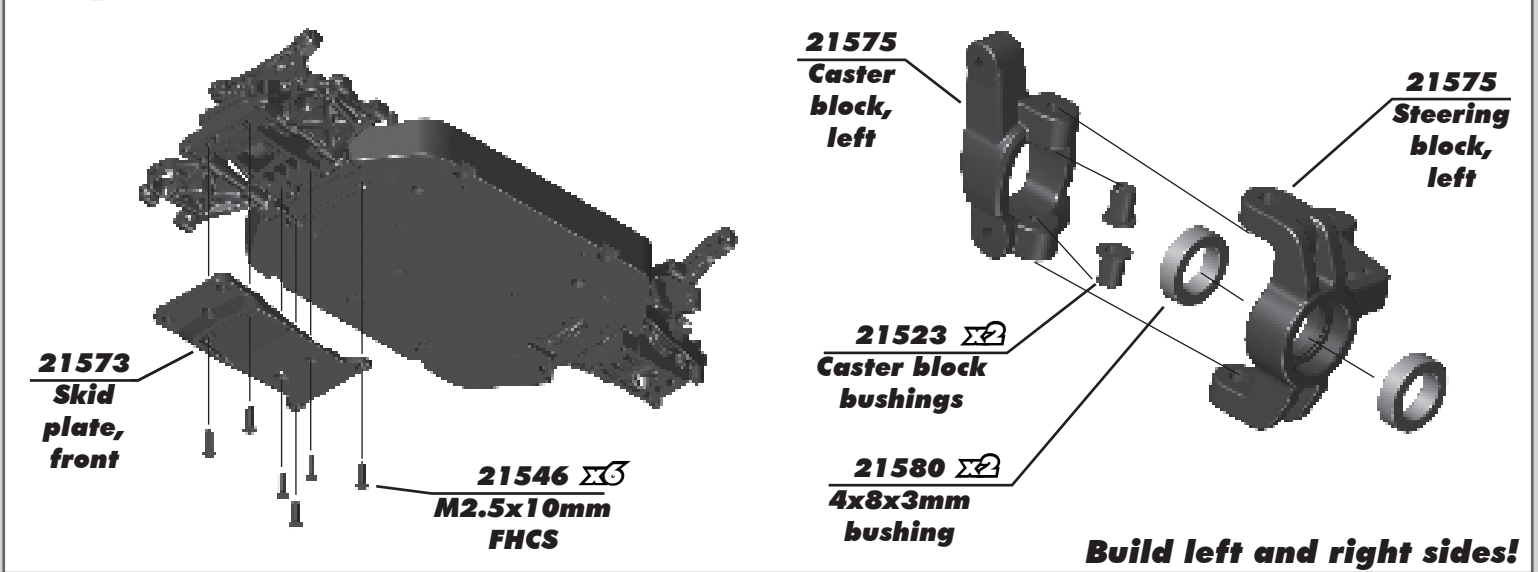

**:: Step 15**

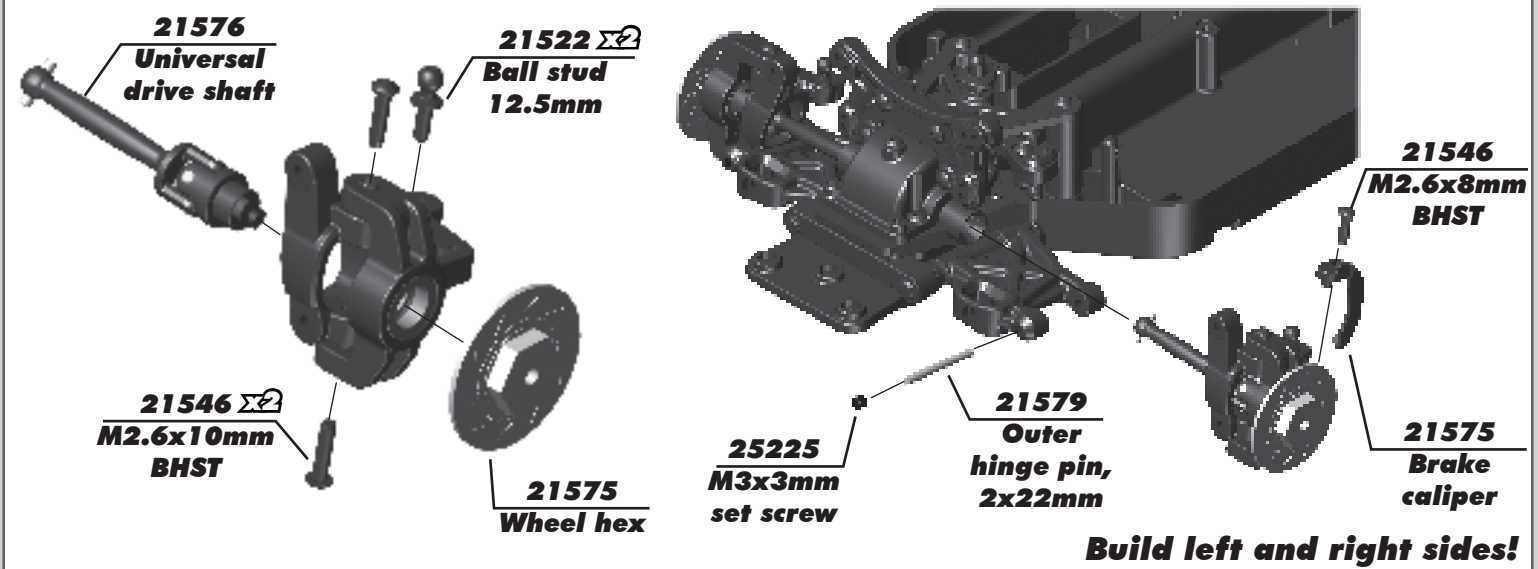

**:: Step 16**

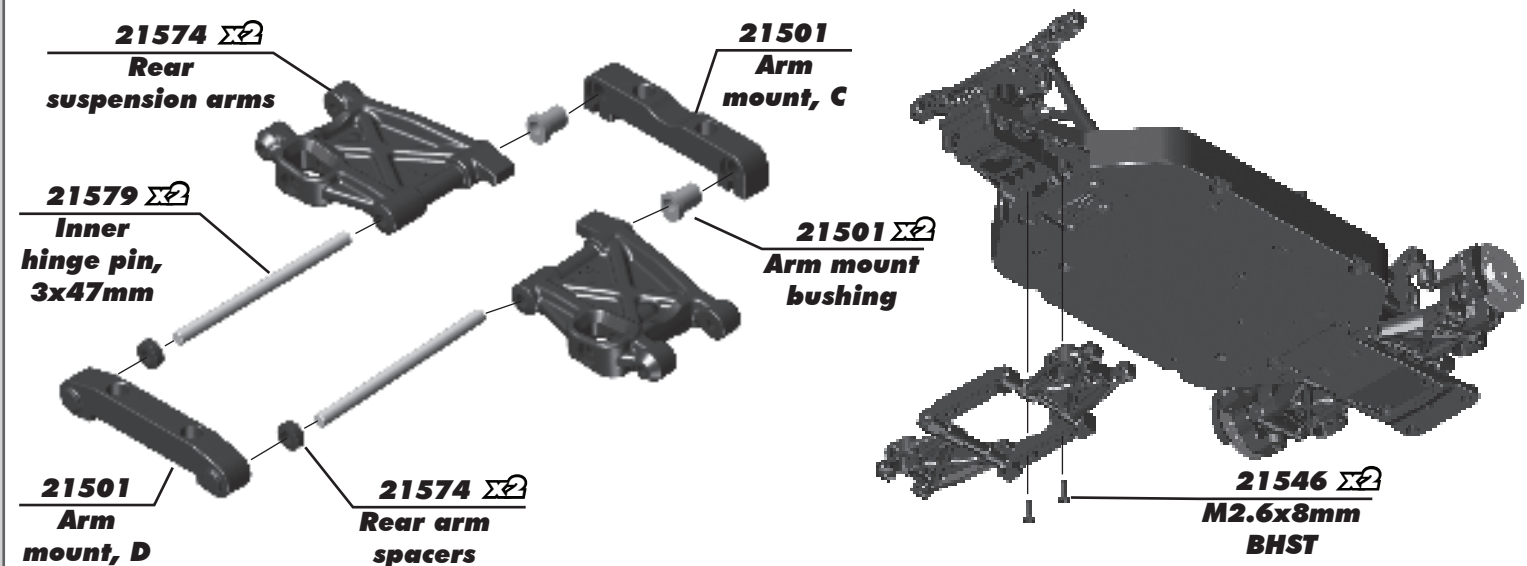

**:: Step 17**

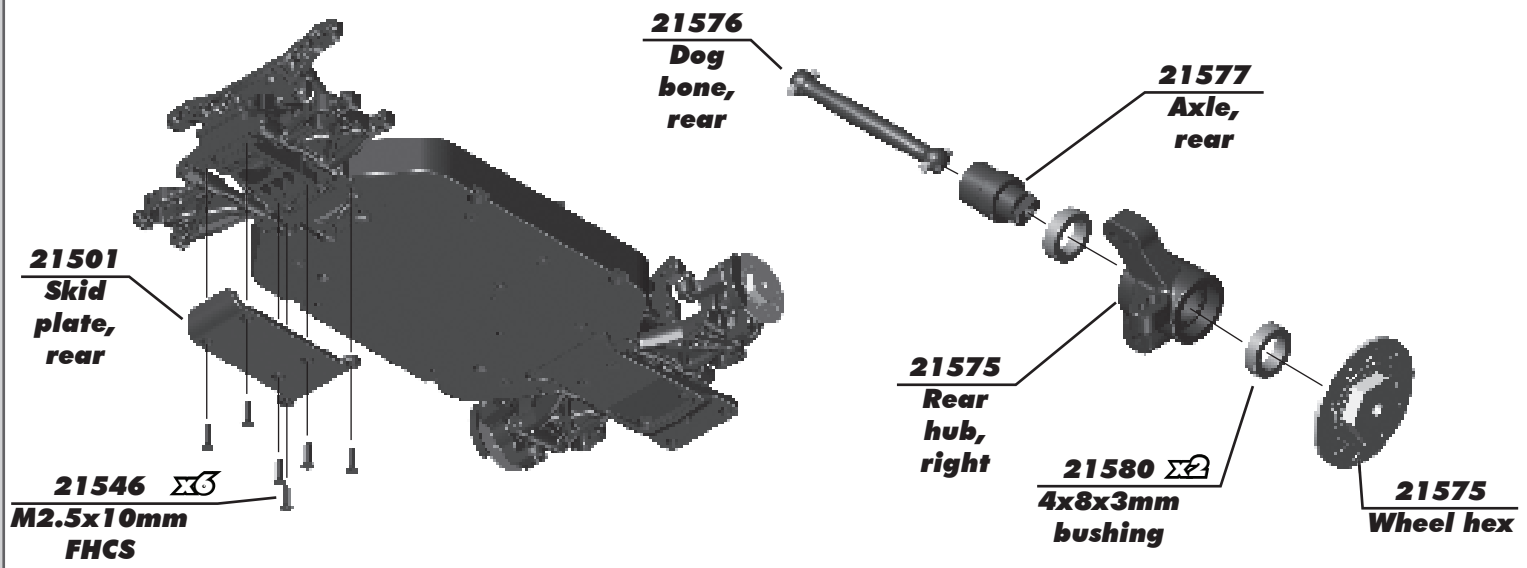

**:: Step 18**

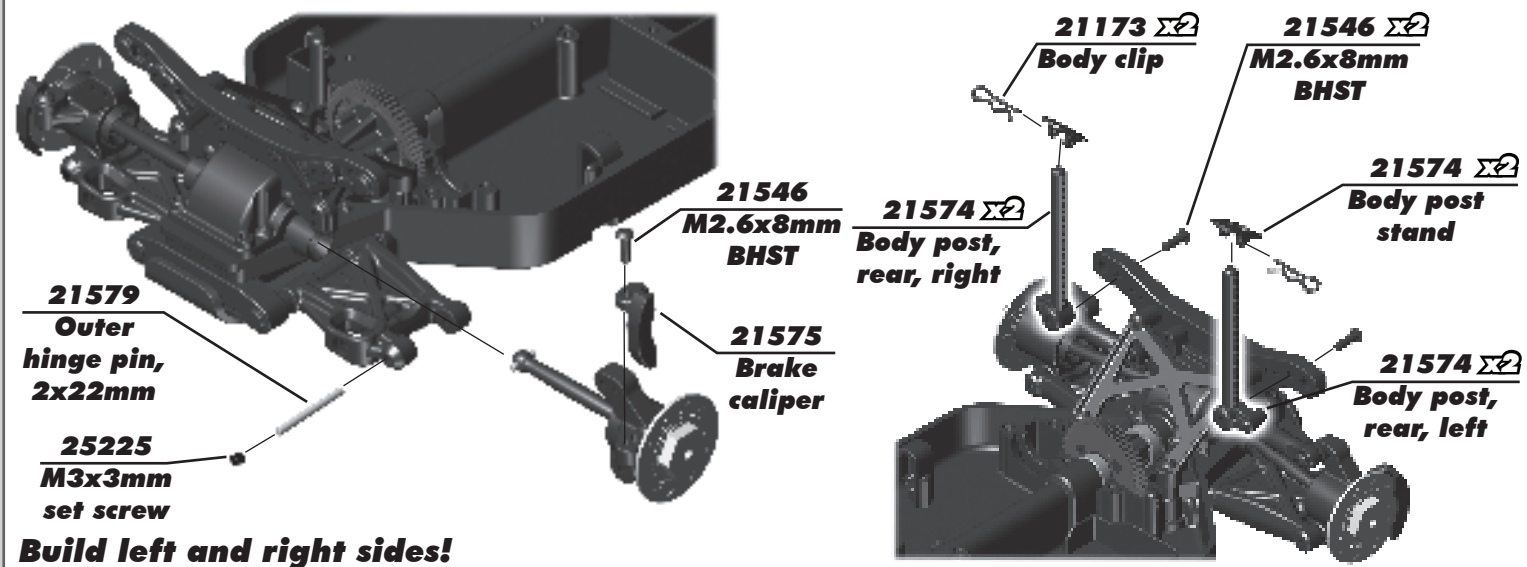

**:: Step 19**

**Build x2 (right and left side)**

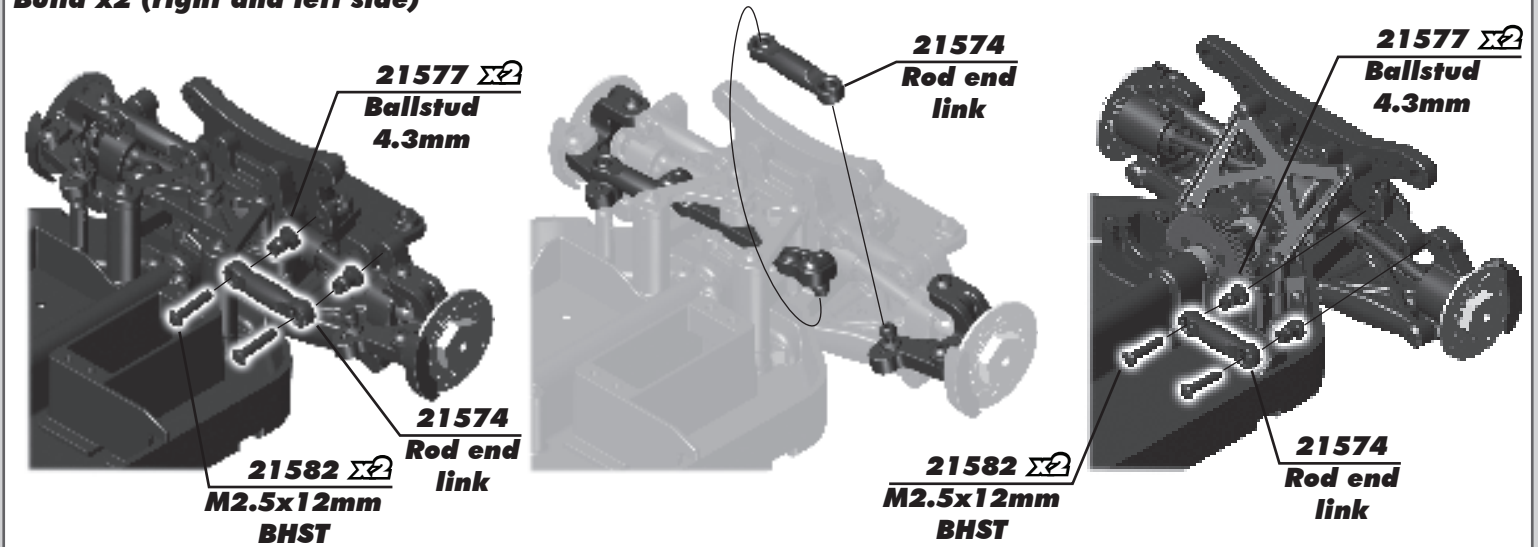

**:: Step 20**

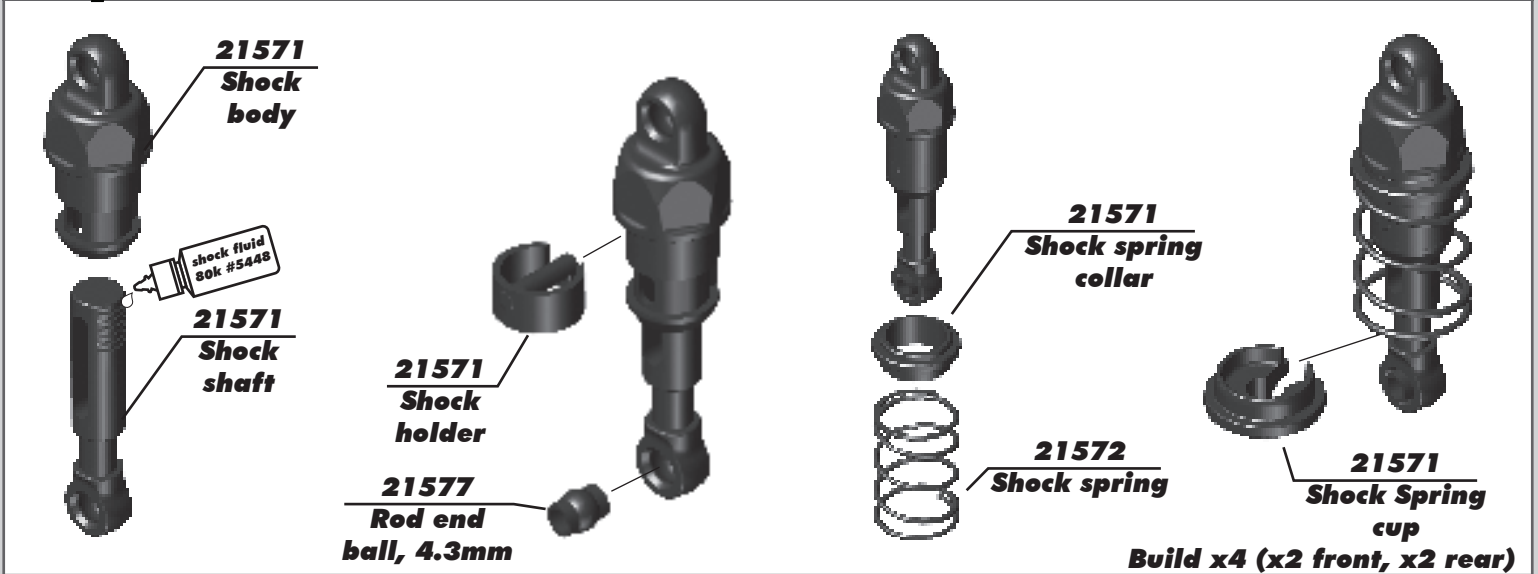

**:: Step 21**

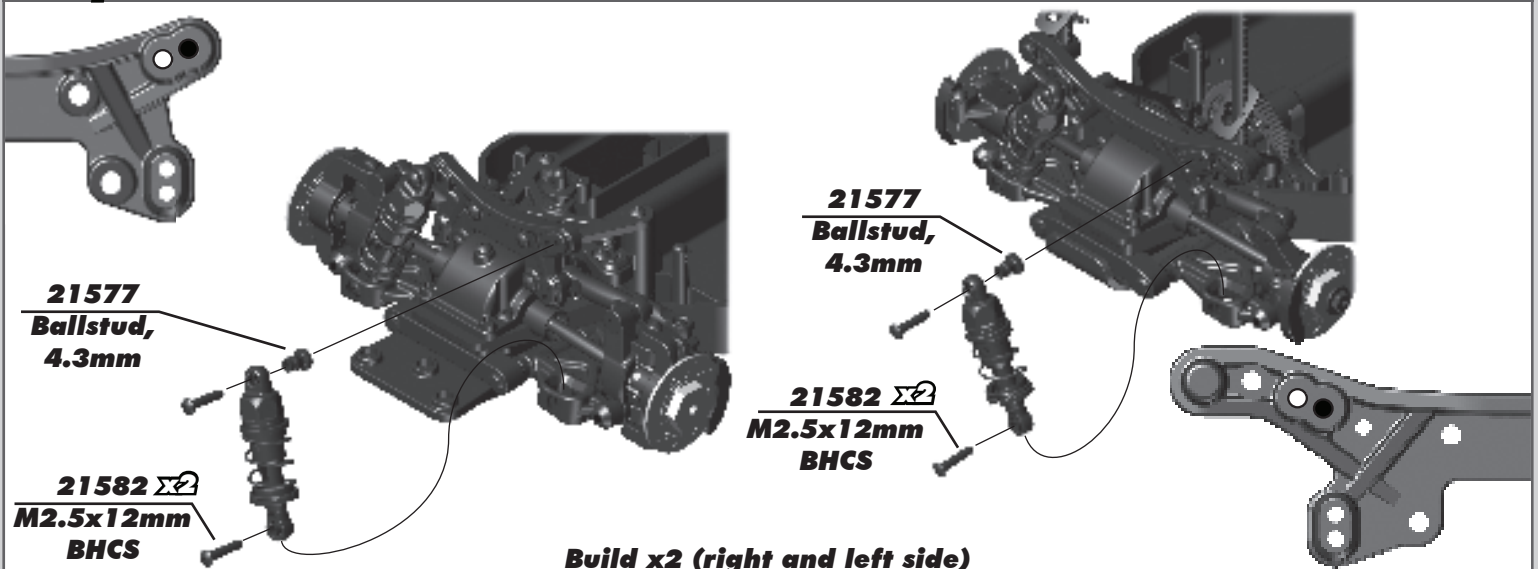

**:: Step 22**

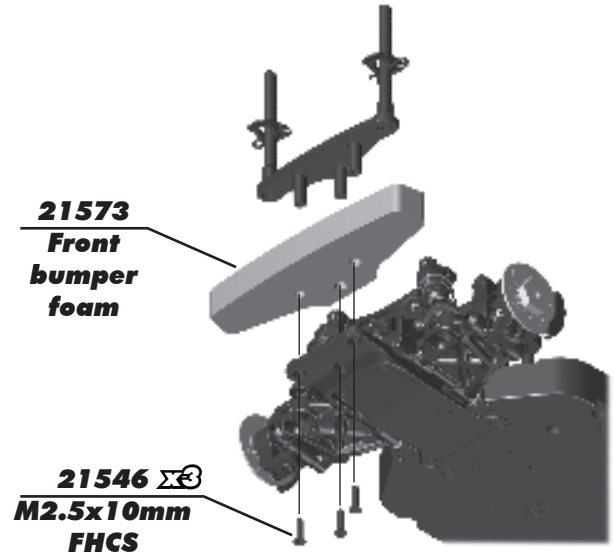
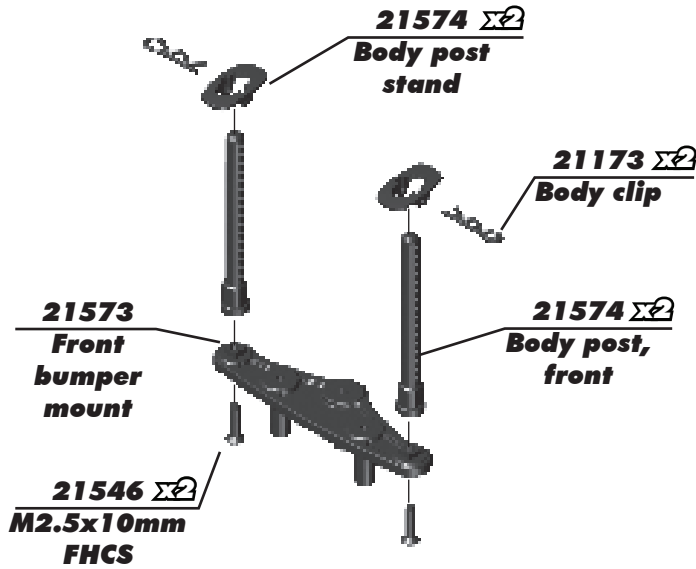

**:: Step 23**

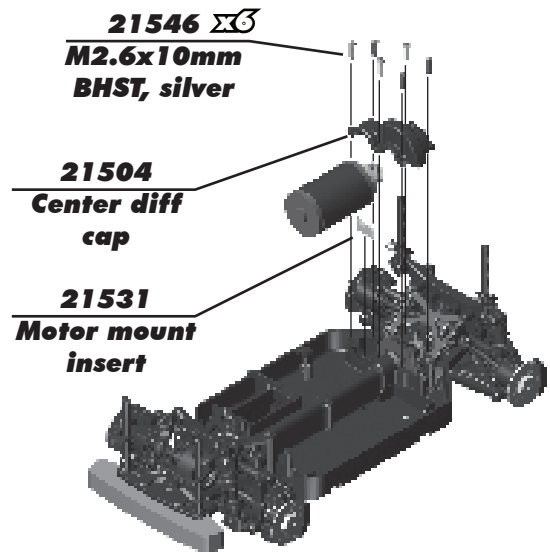
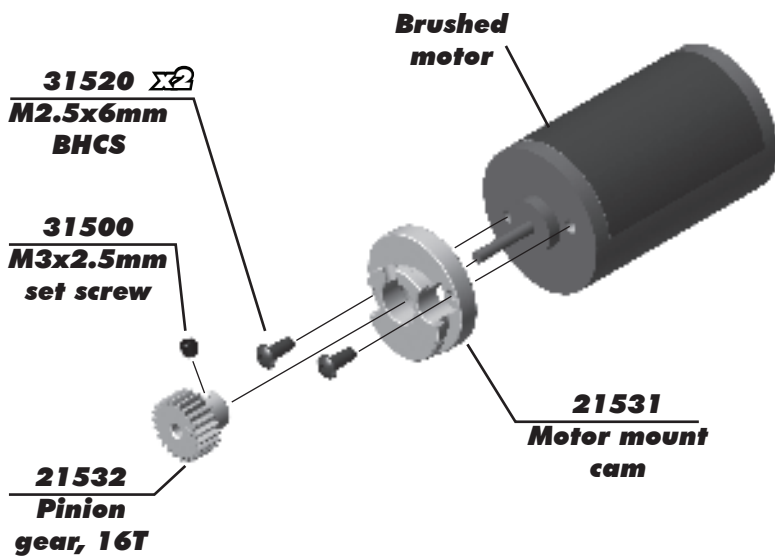

**:: Step 24**

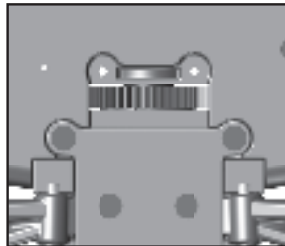

**Set The Gear Mesh:**

To set the gear mesh, push the teeth of the motor mount cam #21531 into the corresponding tooth pattern of the motor mount insert. Once the teeth are seated, you should be able to rock the spur gear back and forth without making the pinion gear move. Excessive amounts of spur gear movement (loose gear mesh) will cause premature gear failure. If the spur gear mesh is tight, there will be no movement between the spur and pinion gears. A gear mesh that is too tight or too loose will reduce power and damage the gear teeth.

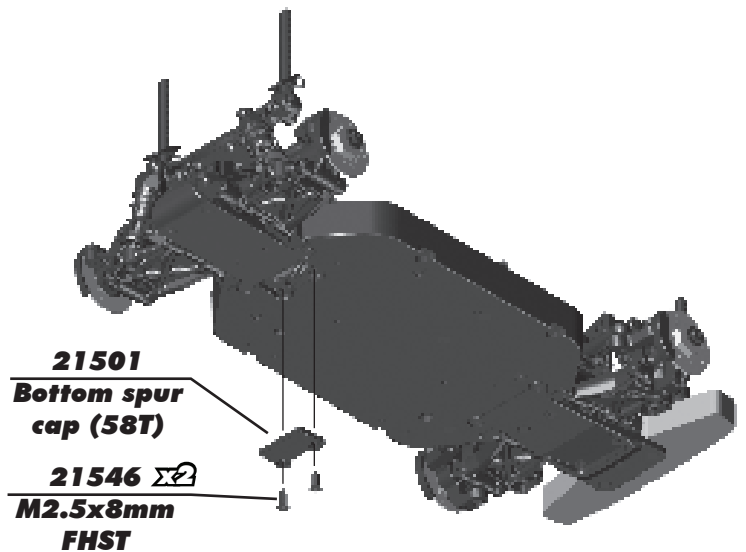

**:: Step 25**

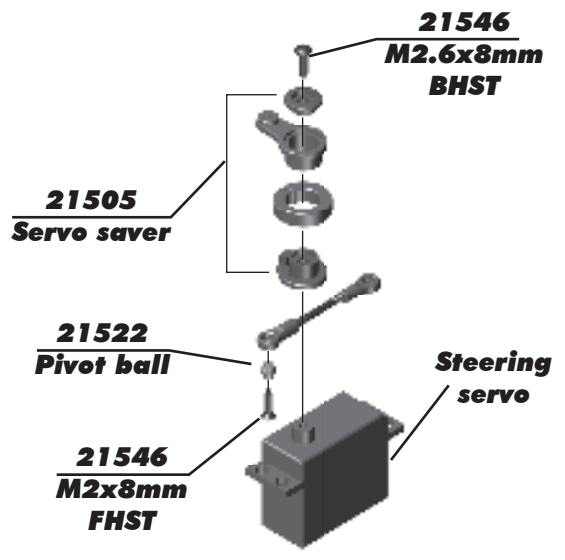
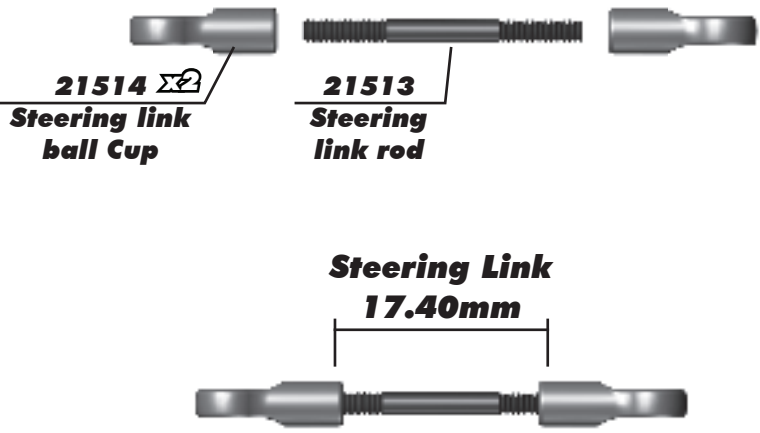

**:: Step 26**

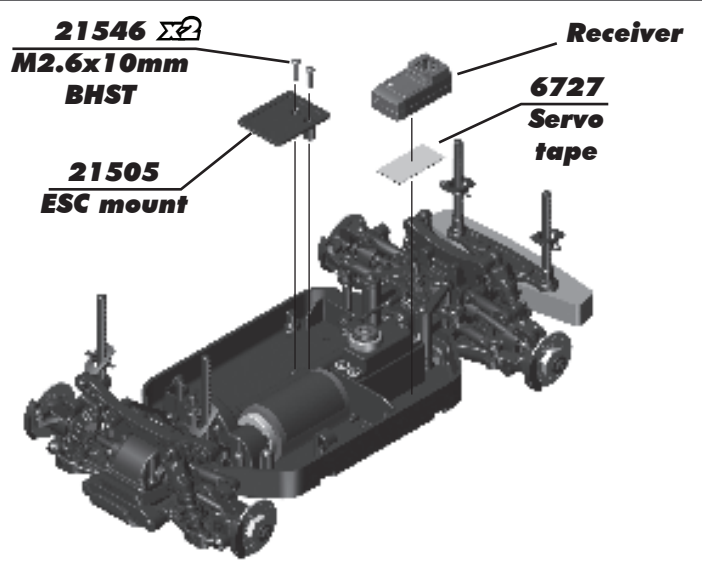
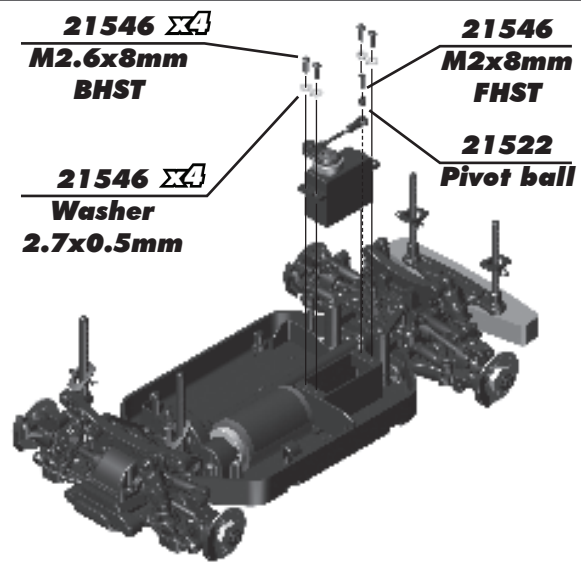

**:: Step 27**

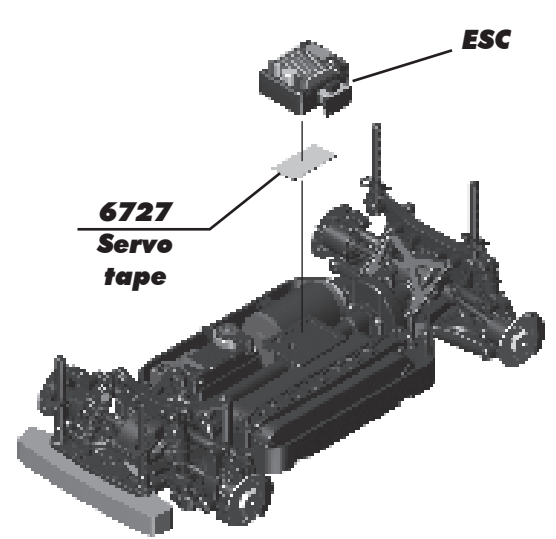
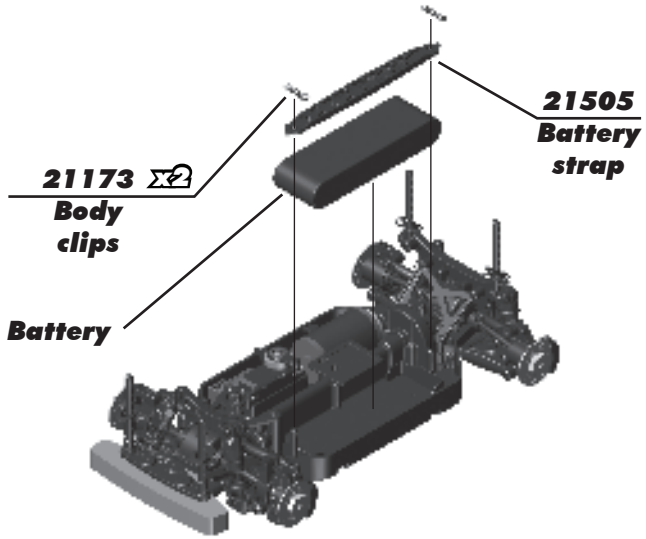

**:: Step 28**

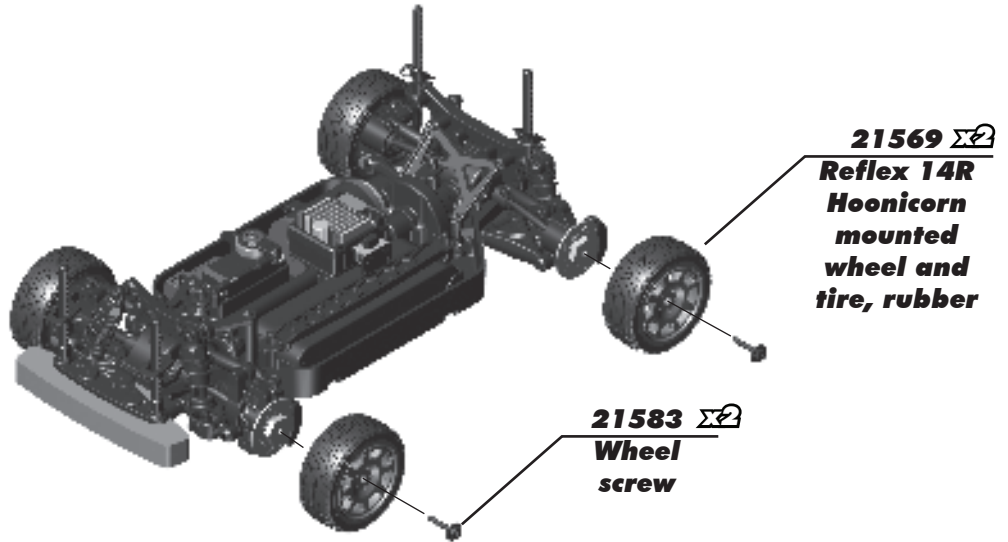

**Install x4 wheel/tires**

**:: Step 29**

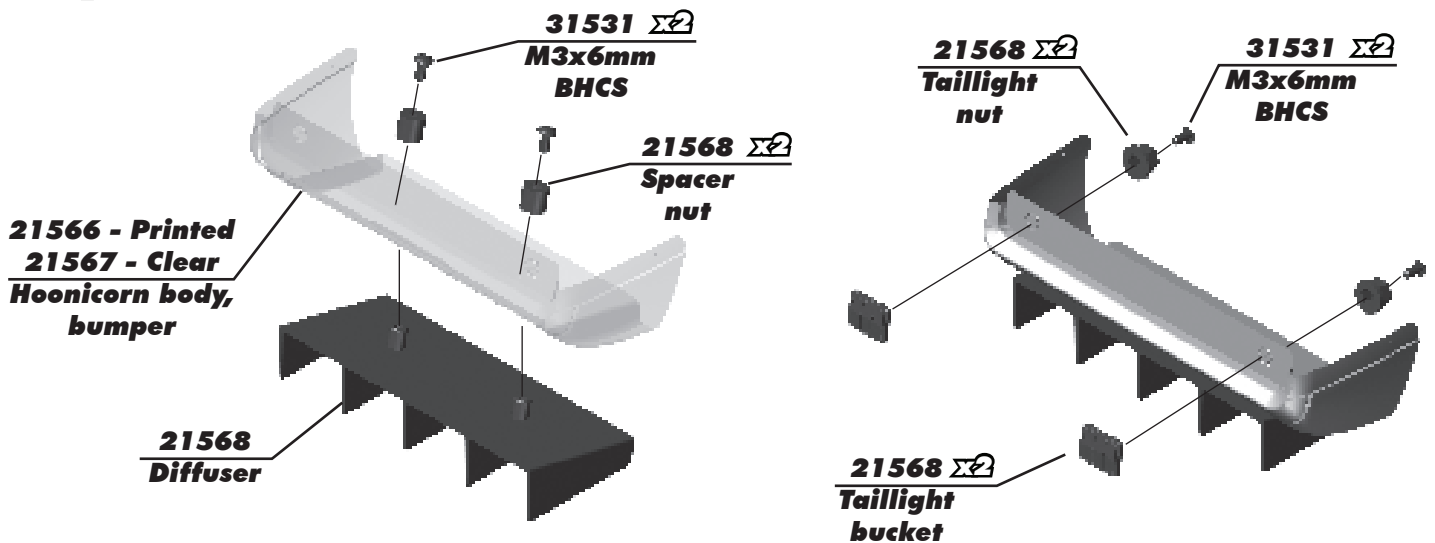

**:: Step 30**

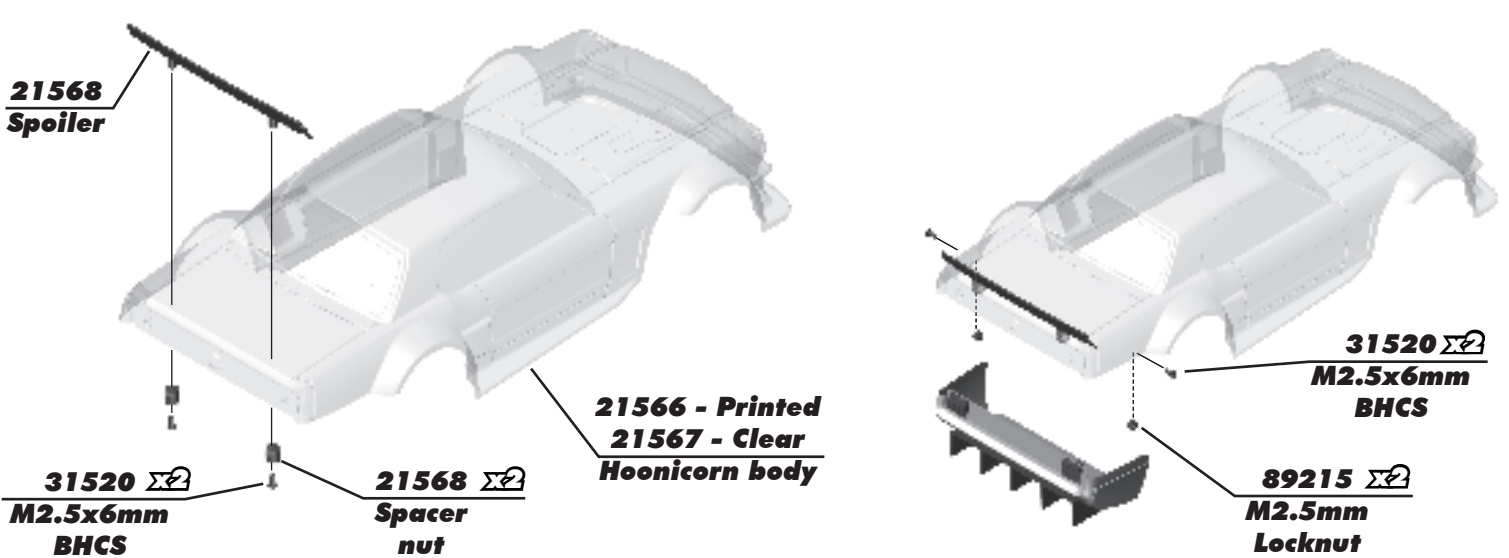

**:: Step 31**

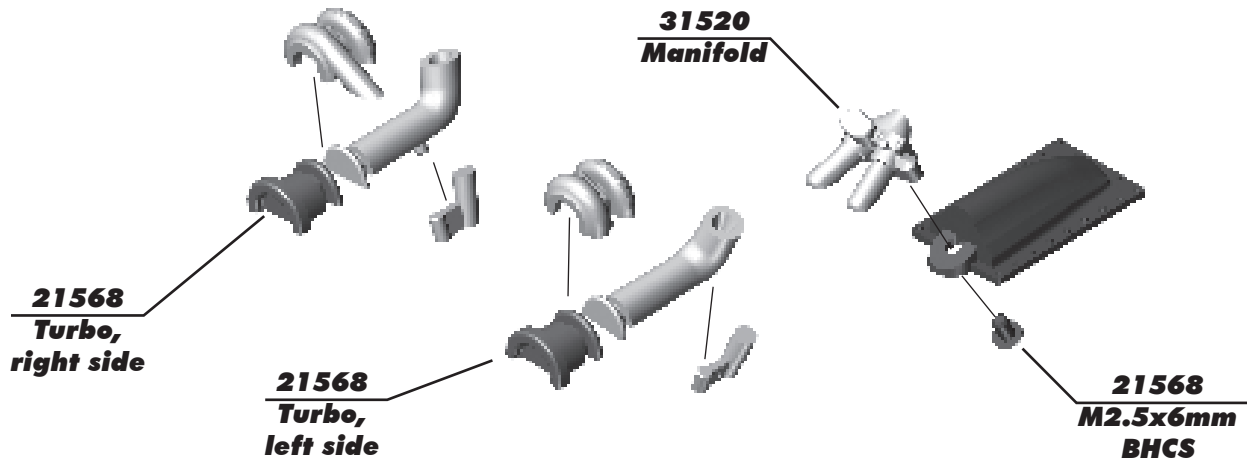

**:: Step 32**

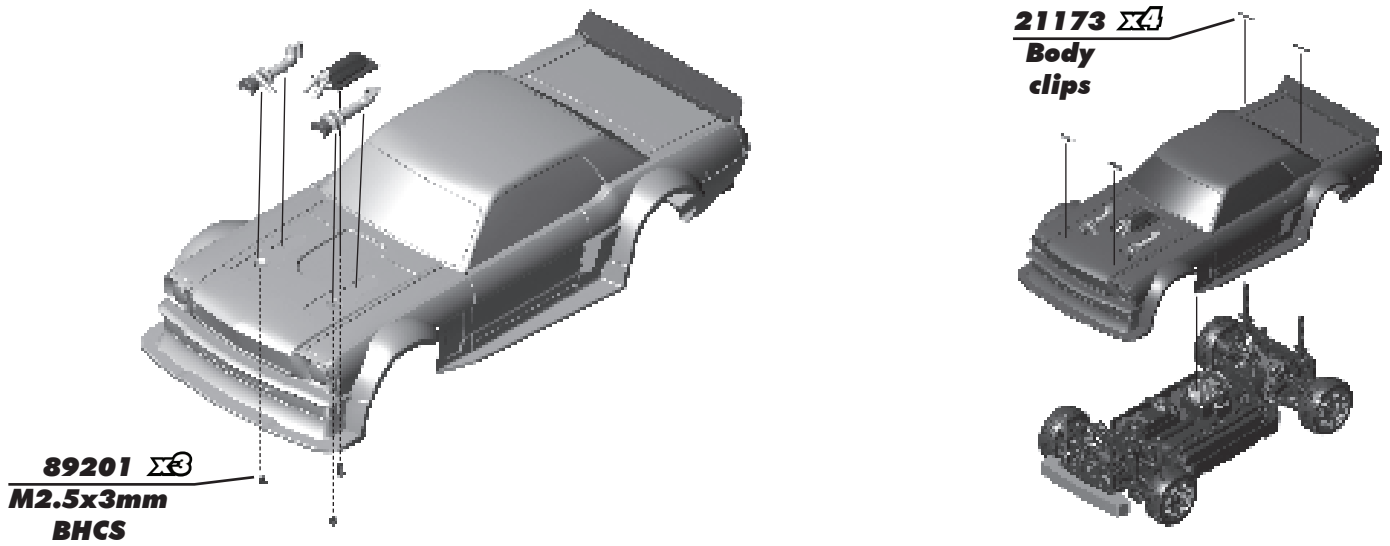

**:: Step 33**

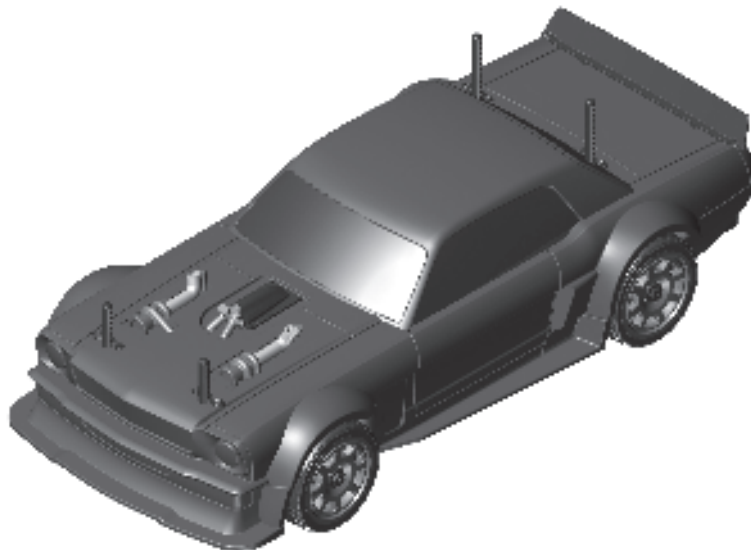

# [HOONIGAN]



## HOONIGAN (HŌON'·Î·GEN) *n.*

A person who operates a motor vehicle in an aggressive and unorthodox manner, consisting of, but not limited to, drifting, burnouts, doughnuts as well as acts of automotive aeronautics.  
One who hoons.

# FIND IT ON ASSOCIATEDELECTRICS.COM



## Vehicle Spare Parts

GO TO:

[AssociatedElectrics.com](#) ➔  
[Team Associated tab](#) ➔  
[Cars & Trucks](#) ➔  
[Scroll to your vehicle](#) ➔  
[Parts & Accessories link](#)



## Setups and Manuals

GO TO:

[AssociatedElectrics.com](#) ➔  
[Team Associated tab](#) ➔  
[Manuals & Setups](#) ➔  
[Scroll to your vehicle](#)



## Tuning Guides & Tips

GO TO:

[AssociatedElectrics.com](#) ➔  
[Support](#) ➔  
[A-Team Apps](#)



**Associated Electrics, Inc.**

**21062 Bake Parkway Lake Forest, CA 92630 USA**

**call: (949) 544-7500 - fax: (949) 544-7501**

**Check out the following web sites for all of our kits, current products,  
new releases, setup help, tips, and racing info!**

**[www.AssociatedElectrics.com](http://www.AssociatedElectrics.com)**

**FOLLOW US ON SOCIAL MEDIA**



**TeamAssociated**  
**ReedyPower**  
**ElementRC**

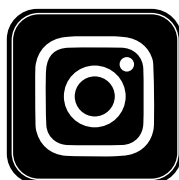

**@TeamAssociatedRC**  
**@ReedyPower**  
**@Element\_RC**



**@Team\_Associated**  
**@ReedyPower**