

# IMDL 130Y (c/w EC motor)

## Ducted Fan Coil Units

## Installation & Maintenance

**Fig. 1 Dimensions (mm)**

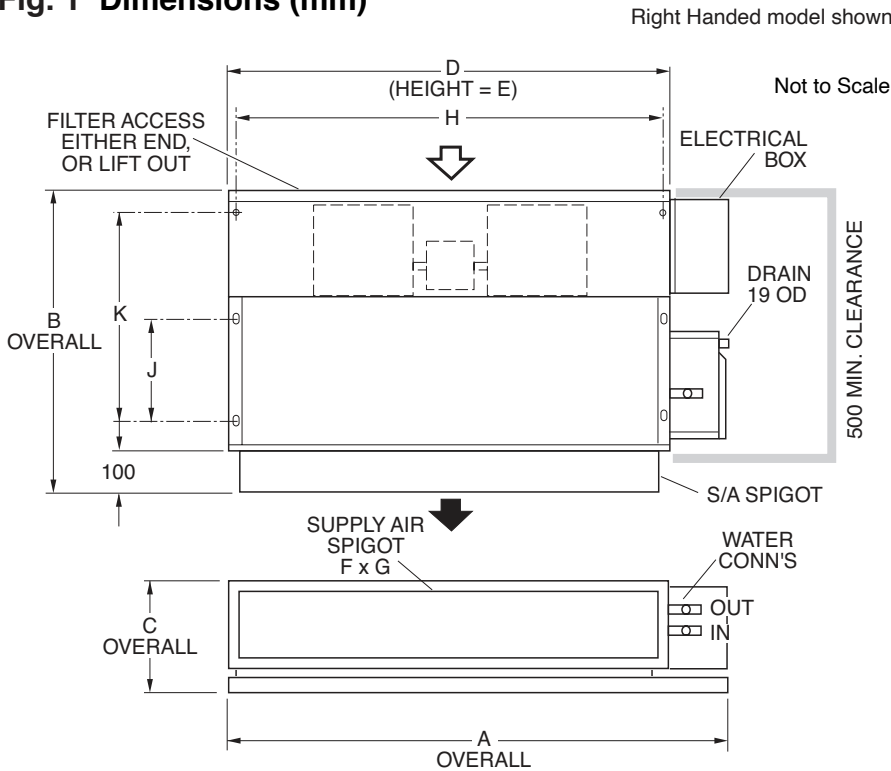

**Note:**

1. Allow adequate clearance for the filter (if fitted) to be removed.
2. IMDL 130 has two half length filters, 2 motors and 3 fans.
3. Left handed models have drain exit nearer supply air side.

MODEL	A	B	C	D	E	F	G	H	J	K	WATER CONN'S BSP MALE	
											COLD	HOT
IMDL 40Y	685	715	255	550	245	512	170	526	225	470	20	13
IMDL 60Y	940	715	255	795	245	762	170	775	225	470	20	13
IMDL 90Y	1195	750	265	1050	255	1012	179	1026	265	510	25	13
IMDL 130Y	1595	750	265	1450	255	1412	179	1427	265	510	25	13

**NOTE**

The manufacturer reserves the right to change specifications at any time without notice or obligation. Certified dimensions available on request.

**GENERAL**

The IMDL-Y ducted fan coil units must be installed in accordance with all national and local safety codes.

**Optional**

1. Supply air spigots adaptors (refer Fig.2).
2. Flexible hoses:
  - 13 BSP (1/2") part no. 060-000-270
  - 20 BSP (3/4") part no. 060-000-271
  - 25 BSP (1") part no. 060-000-272.
3. Electric heater elements (factory fitted).

**INSTALLATION**

**Positioning & Mounting**

Provide 500 mm minimum clearance to the electrical box end of the unit.

Allow adequate clearance for the filter to be withdrawn to its full length from either end of the unit. Alternatively the filter may be lifted out of its track.

Left handed models have drain exit on supply air side of the drain tray.

Install the unit suspended on threaded rods or bolts and locking nuts (not supplied). Alternatively mount each unit on vibration isolators on a suitable platform.

The unit must be installed level. Use the adjustable support bracket (see figure 3) to lower the drain pipe outlet and provide a slope in the drain tray.

**WATER SUPPLY & RETURN**

The IMDL unit's IN and OUT water connections are male pipe threaded (refer Fig. 1). **Warning:** overtightening of connections to the main water supply may damage the unit.

It is recommended you use two **temperzone** 600 mm flexible high pressure water hoses. These have female pipe threaded connections at each end. Maximum water pressure for each hose is 1720 kPa (250 psi). The IMDL unit alone, excluding hoses, will withstand 4480 kPa (650 psi).

Poor quality water supply must be pre-filtered and it is essential that adequate water treatment is maintained, particularly where open cooling towers are used.

**Condensate Drain**

The drain should have a slope of at least 1 in 50 and must not be piped to a level above the unit drain tray. Fit a vent pipe within 500 mm of the unit (see Fig.3). Check the drain by pouring water into the drain tray and ensuring that it clears.

**Fig. 2 Optional Supply Air Spigots**

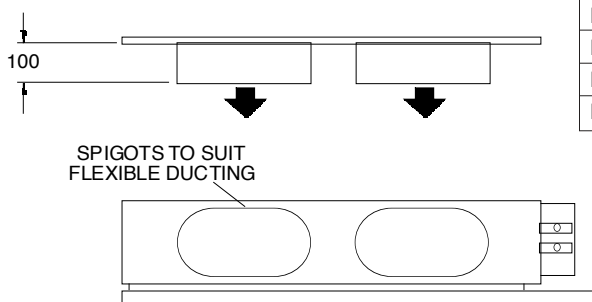

MODEL	SPIGOTS
IMDL 40	200 dia (x2)
IMDL 60	250 dia (x2)
IMDL 90	250 dia (x3)
IMDL 130	250 dia (x4)

## ELECTRICAL WIRING

Electrical work must be carried out by a qualified electrician in accordance with local supply authority regulations and the wiring diagram.

The electrical supply required is:

1 phase 230V a.c. 50Hz with neutral and earth. A lockable motor rated isolator switch shall be fitted as close as possible to the unit. Refer wiring diagrams for max. operating current.

Wire the unit directly from the electrical distribution board. The unit shall have its own dedicated circuit breaker on the Distribution Board.

*Units with Electric Heat:* A 24V ac externally sourced power connection is required to control the optional electric heater elements via the solid state relay (SSR); refer wiring diagram (page 4).

## FAN CONTROL

### Overview

The fan can be controlled between selectable low and high levels using either:

- 0–10V DC control voltage (ie continuously variable), **or**
- (up to) 3 contact inputs (ie stepped).

Only one control method must be connected at any one time; **not both**.

Fan run on is provided with durations suiting water sourced and electric heating systems.

### Control Levels (Output Voltages)

DIP switches 1-4 of the Analog Level Controller (ALC on wiring schematics) select the low fan control voltage level. DIP switches 5 and 6 select the high fan control voltage level as a set amount above the low level.

The medium level setting is half way between the low and high setting levels.

The control voltage settings apply to both 0-10V and contact input control levels.

Refer to the wiring schematic diagram for the default settings and the available level settings.

### Contact Inputs

Voltage free contact inputs can be used to operate the fan at the selected control levels.

### 0-10V Input

A 0–10V DC signal can be used to control the fan. The fan is stopped for input signals below 1.6V. The fan operates at the selected low level when the input signal is between 1.6 and 2.0V. As the input signal increases above 2V the fan control signal increases linearly reaching the selected high level when the input signal is 10V.

Note: Minimum control voltage is 4V for units with electric heat.

### Run-On

The run on duration is selected with DIP switch 8 for either 40 seconds or 120 seconds for electric heating systems. If electric heating is fitted ensure DIP switch 8 is set on for 120 seconds run-on.

The fan will run-on for the selected period when the 0–10V input falls below 1.6V and all the contact inputs are opened. If the 0–10V input signal remains below 1.6V and the contact inputs remain open the fan will stop at the end of the run-on period.

**Note:** Select fan control levels that avoid water carry-over problems.

## ELECTRIC HEAT (Option)

Units installed with electric heat elements include both auto (90°C) and manual (120°C) high temp. safety thermostats. If the manual high temp. safety t/stat requires resetting and the auto high temp. safety t/stat does not reset, then the latter needs to be replaced.

Note: The minimum control voltage is raised to 4V to ensure adequate heat dissipation from the electric elements.

## COMMISSIONING

- Check that the thermostat is correctly wired and set at the desired temperature.
- Check that the air filter is clean.
- Check that the fan runs freely without vibration.
- Check condensate drain for free drainage.

## MAINTENANCE

### Weekly For First Four Weeks

- Check air filter; vacuum clean as necessary.
- Check condensate drain for free drainage.

### Monthly

Check air filter; vacuum clean as necessary.

### Six Monthly

- Check condensate drain for free drainage.
- Check heat exchanger coil; vacuum or brush clean as necessary.
- Check the tightness of the fan.
- Check that fan motor is free running.
- Check tightness of electrical connections.
- Check air supply at diffuser outlets.

## NOTE

The manufacturer reserves the right to change specifications at any time without notice or obligation. Certified dimensions available on request.

**Fig. 3 Condensate Drain**

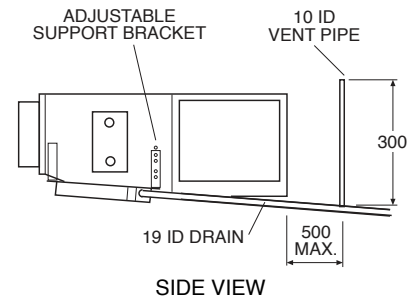

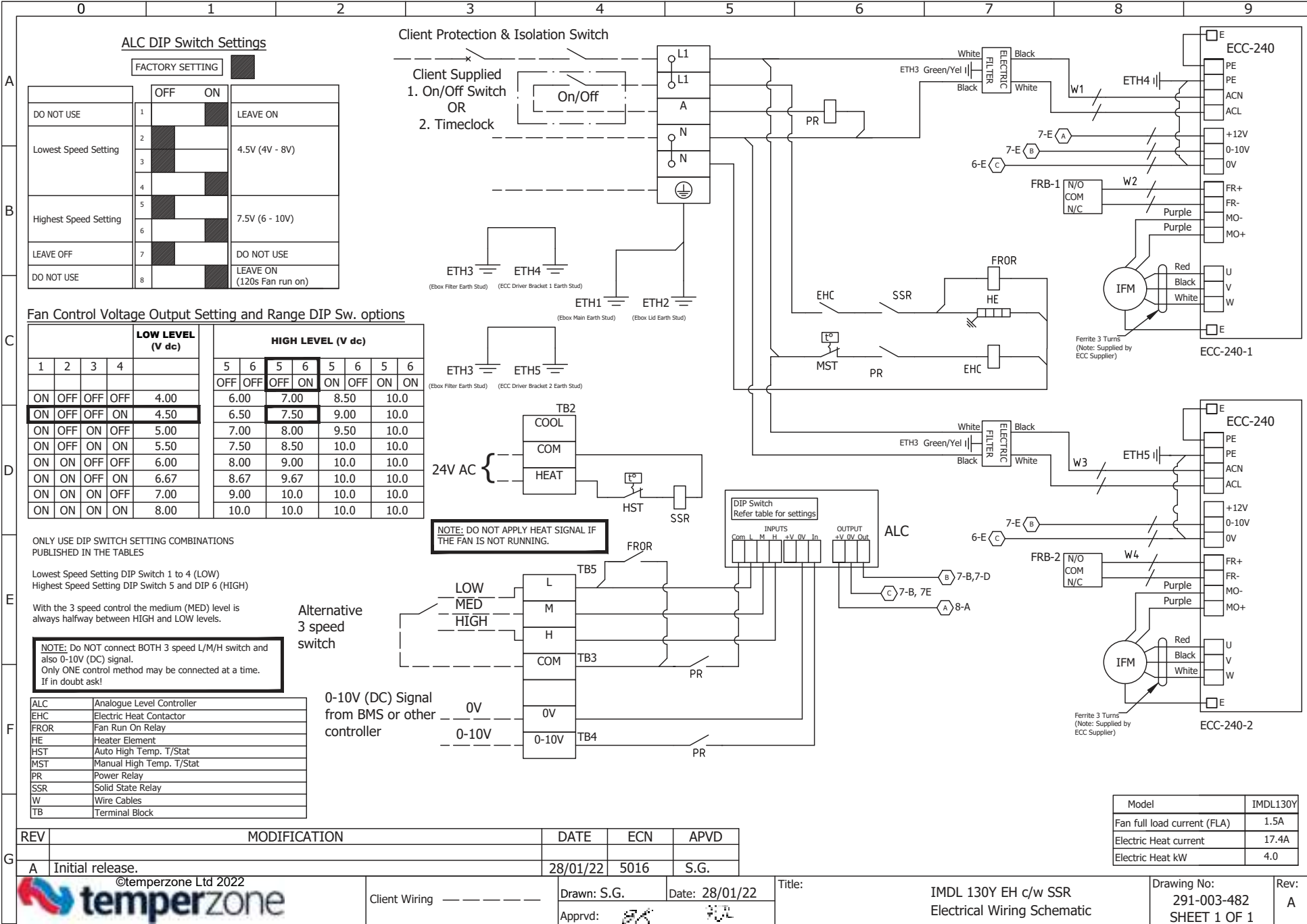

**ALC DIP Switch Settings**

FACTORY SETTING		OFF	ON	
DO NOT USE	1		■	LEAVE ON
Lowest Speed Setting	2	■		4.5V (4V - 8V)
	3	■		
	4	■		
Highest Speed Setting	5	■		7.5V (6 - 10V)
	6	■		
LEAVE OFF	7	■		DO NOT USE
DO NOT USE	8		■	LEAVE ON (120s Fan run on)

**Client Protection & Isolation Switch**

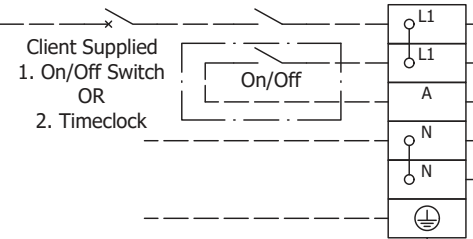

**Fan Control Voltage Output Setting and Range DIP Sw. options**

LOW LEVEL (V dc)				HIGH LEVEL (V dc)								
1	2	3	4	5	6	5	6	5	6	5	6	
ON	OFF	OFF	OFF	4.00	OFF	OFF	OFF	ON	ON	OFF	ON	ON
ON	OFF	ON	OFF	5.00	7.00	7.50	9.00	10.0				
ON	OFF	ON	ON	5.50	7.50	8.50	10.0	10.0				
ON	ON	OFF	OFF	6.00	8.00	9.00	10.0	10.0				
ON	ON	OFF	ON	6.67	8.67	9.67	10.0	10.0				
ON	ON	ON	OFF	7.00	9.00	10.0	10.0	10.0				
ON	ON	ON	ON	8.00	10.0	10.0	10.0	10.0				

ONLY USE DIP SWITCH SETTING COMBINATIONS PUBLISHED IN THE TABLES

Lowest Speed Setting DIP Switch 1 to 4 (LOW)  
Highest Speed Setting DIP Switch 5 and DIP 6 (HIGH)

With the 3 speed control the medium (MED) level is always halfway between HIGH and LOW levels.

**NOTE:** Do NOT connect BOTH 3 speed L/M/H switch and also 0-10V (DC) signal.  
Only ONE control method may be connected at a time.  
If in doubt ask!

ALC	Analogue Level Controller
EHC	Electric Heat Contactor
FROR	Fan Run On Relay
HE	Heater Element
HST	Auto High Temp. T/Stat
MST	Manual High Temp. T/Stat
PR	Power Relay
SSR	Solid State Relay
W	Wire Cables
TB	Terminal Block

Alternative 3 speed switch

0-10V (DC) Signal from BMS or other controller

**NOTE:** DO NOT APPLY HEAT SIGNAL IF THE FAN IS NOT RUNNING.

REV	MODIFICATION	DATE	ECN	APVD
A	Initial release.	28/01/22	5016	S.G.



Client Wiring \_\_\_\_\_  
 Drawn: S.G. Date: 28/01/22  
 Apprvd: \_\_\_\_\_

Title: IMDL 130Y EH c/w SSR  
 Electrical Wiring Schematic

Model	IMDL130Y
Fan full load current (FLA)	1.5A
Electric Heat current	17.4A
Electric Heat kW	4.0

Drawing No: 291-003-482  
 SHEET 1 OF 1  
 Rev: A

