

INSTALLATION MANUAL

54-inch XTREME Mulch Kit — 19A30042*

Model 19A30042OEM mulch kit is designed for use with select 54-inch triple-blade stamped cutting decks and fabricated cutting decks. Refer to your tractor's Operator's Manual to assure compatibility.

Carton Contents

Before beginning installation, remove all parts from the carton to make sure everything is present. Carton contents are listed below and shown in Figure 1-1. Part numbers are shown in parentheses.

- Three Mulching Blades (942-05056-X)
- One 54" Deck Mulch Plug Assembly (631-05178)
- One Wing Knob (720-04122)
- One Chute Adapter (731-10133)

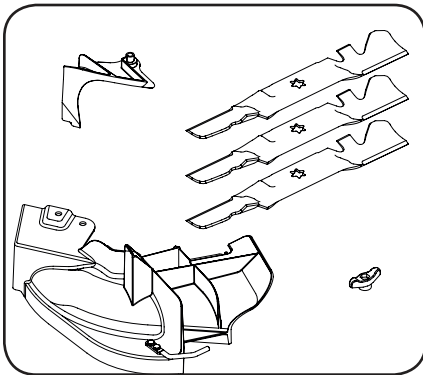

Figure 1-1

Blade Installation



WARNING: Before beginning installation, place the tractor on a firm and level surface, set the parking brake, place the PTO in the disengaged (OFF) position, stop the tractor's motor and remove the ignition key to prevent unintended starting.



WARNING: Cutting blades are sharp. Always protect hands by wearing heavy leather work gloves to grasp blades.

1. Remove the cutting deck from beneath the tractor as instructed in your tractor's Operator's Manual.
2. Gently flip the deck over to expose its underside.
3. Stabilize one of the cutting blades with a blade lock tool or a block of wood. See Figure 1-2.

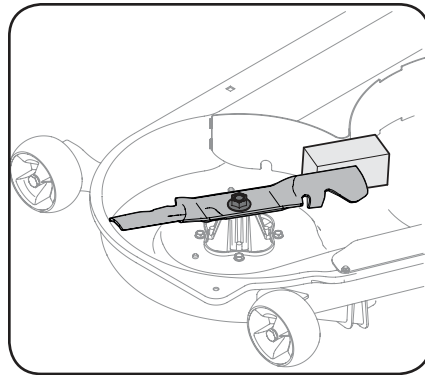

Figure 1-2

4. Remove the hex flange nut that secures the blade to the spindle.

IMPORTANT: The hex flange nuts have a right-handed (normal) thread pattern. Do NOT attempt to force the nuts in the opposite direction. Doing so may damage the nuts.

5. Repeat steps 2 and 3 on the other cutting blades.
6. Replace the blades with the blades included in the kit. Be sure to install each blade with the side marked "Bottom" (or with a part number stamped in it) facing the ground when the mower is in the operating position.

IMPORTANT: Use a torque wrench to tighten each blade spindle's hex flange nut to between 80 ft-lb and 100 ft-lb. (*Stamped deck*) or 100 ft-lb and 120 ft-lb (*fabricated deck*).

Installing the Mulch Plug

1. Pivot the chute deflector upward and remove the protective cover from the pin found on the deck's surface. See Figure 1-3.

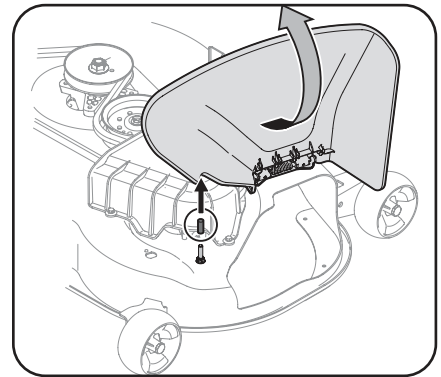

Figure 1-3

2. On 54-inch **Stamped Decks Only**, position the chute adapter over the pin. See Figure 1-4.

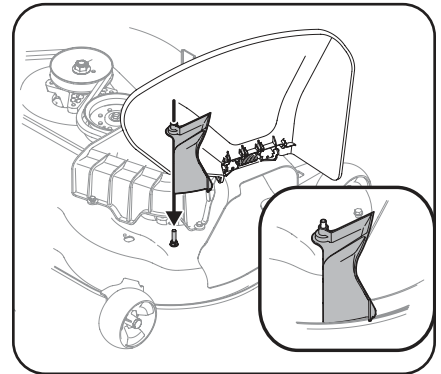

Figure 1-4



3. To install the mulch plug, pivot the discharge chute upward. Refer to Figure 1-5 (*fabricated decks*) or Figure 1-6 (*stamped decks*):
 - a. Insert the mulch plug into the discharge chute opening.
 - b. Insert the mulch plug rod into the hole found on the front, right deck wheel bracket.
 - c. Position the rear of the mulch plug over the pin found on the deck's surface.

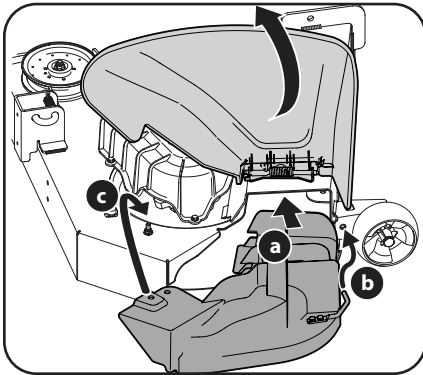

Figure 1-5

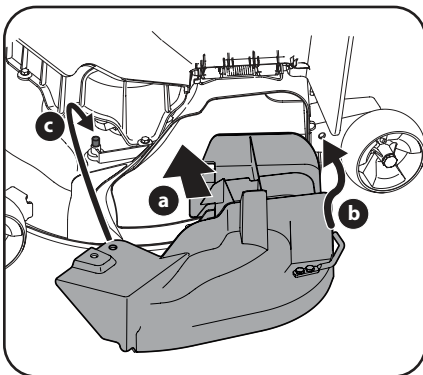

Figure 1-6

Important: Be certain that the bottom of the mulch plug is installed down inside of the lip of the deck opening, as shown in Figure 1-7.

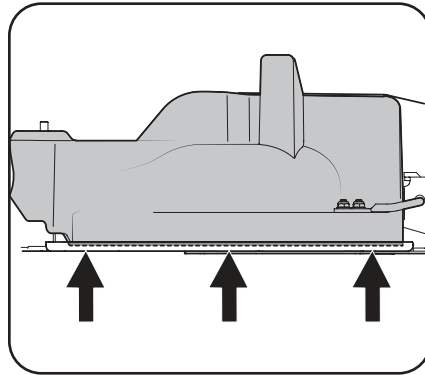

Figure 1-7

4. Secure the mulch plug in place with the wing knob. See Figure 1-8 (*fabricated decks*) or Figure 1-9 (*stamped decks*).

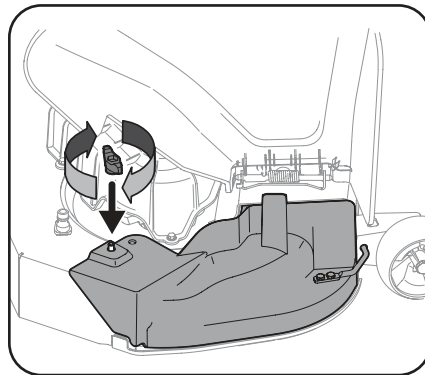

Figure 1-8

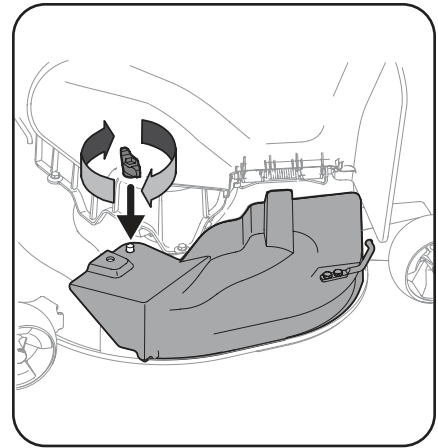

Figure 1-9

5. With the mulch plug in place, the discharge chute will remain propped-up so that the operator can more easily maneuver the tractor's deck near and around trees and other obstacles.