



12VAC FIRE BOWL INSTALLATION

GENERAL INFORMATION

Please carefully follow the instructions in this manual to prevent personal injury or property loss. Instructions are updated as needed. It is the installer's responsibility to periodically review instruction for applicable updates.

The steps listed as

WARNING: Contains information critical to the safe installation and operation of the fire bowl.

WARRANTY REQUIREMENT: Must be strictly followed to qualify for product warranty. Warranty will be void if not followed.

IMPORTANT: Notes and insights to help ensure product satisfaction and serviceability.

WARNING: It is the installer's responsibility to ensure a safe installation and to educate the end user as to proper operation. Leave this manual with the end user.

WARNING: Never alter product or configuration in any way.

WARNING: We suggest that our products be installed by professionals that are locally licensed by the authority having jurisdiction in gas piping. We suggest that our products be serviced annually by a professional certified in the US by the National Fireplace Institute (NFI) as NFI Gas Specialists or in Canada by WETT (Wood Energy Technical Training). Installer must follow all instructions carefully to ensure proper performance and safety. The Outdoor Plus Co, Inc is not responsible for your actions.

WARNING: Product is not intended to be a starter for wood or any other combustibles.

WARNING: It is the responsibility of the installer to follow:

- The National Fuel Gas Code, ANSI Z223.1/NFPA 54 or International Fuel Gas Code.
- The National Electrical Code, ANSI/NFPA 70.
- Local Codes

WARNING: Verify correct gas/fuel type and pressure. Never use an alternative fuel to include bio-fuel, ethanol, lighter fluid or any other fuel. Gas pressure and type should be checked prior to use and installation.

- Natural Gas Fire bowl:
Supply Pressure: Minimum: 3.5" W.C.; Maximum: 7.0" W.C.
- Liquid Propane Gas:
Supply Pressure: Minimum: 8.0" W.C.; Maximum: 11.0" W.C.

SELECTING THE LOCATION

WARNING: All fire bowls, match lit kits, and spark ignition systems are designed and intended for outdoor use only.

WARNING: All fire bowls must have a gas shutoff on the outside of the exterior of the fire bowl to allow for emergency shut off and maintenance.

WARNING: Select a location where the fire bowl can be attended during operation. Never leave an operating fire bowl unattended or by someone not familiar with its operation or emergency shut off locations.

WARNING: Both children and adults should be alerted to the hazards of high surface temperatures and should stay away to avoid burns and clothing ignition.

WARNING: Young children should be carefully supervised when they are in the area of fire bowl.

WARNING: Clothing or other flammable materials should not be placed on or near fire bowl.

WARNING: Fire bowls create very high temperatures - Combustibles must be located far enough away that there is no risk of ignition. (See Clearance From Combustibles diagram at the end of this document)

Fire bowl Clearances from Combustibles (Diagram can be found at the end of this document)
Sides Surrounding Fire bowl - 48" From Structure or Combustibles
Overhead Clearance - 96" from combustibles overhead

IMPORTANT: It is recommended that material such as granite, marble or other dense stone be kept away from heat and especially flame due to risk of cracking. Manufacturer is not responsible for damage.

TIPS FOR CHOOSING LOCATION

- Select a location with good drainage.
- Choose a location that allows easy access for installation and maintenance of the fire bowl.
- Pick a location that allows sufficient room to enjoy the fire bowl while allowing a safe distance from the heat and flame.



12VAC FIRE BOWL INSTALLATION

Gas and Electricity Requirements

FUEL TYPE - Before making gas connections, ensure appliance being installed is compatible with the available gas type. Check the label on the appliance to confirm appliance gas type.

GAS PRESSURE - Proper input gas pressures are required for optimum appliance performance

GAS PRESSURE REQUIREMENTS

Pressure	Natural Gas	Propane
Minimum	3.5" W.C. / 1/8 psi	8.0" W.C. / 1/3 psi
Nominal	7.0" W.C. / 1/4 psi	11.0" W.C. / 1/3 psi
Maximum	14.0" W.C. / 1/2" psi	14.0" W.C. / 1/2 psi

WIRE GAUGE REQUIREMENT BASED ON DISTANCE

Distance in Feet	10 ft.	20 ft.	30 ft.	40 ft.	50 ft.	60 ft.	70 ft.	80 ft.	90 ft. +
6AWG	12 VAC	12 VAC	12 VAC	13 VAC	13 VAC	13 VAC	13 VAC	13 VAC	14 VAC
8AWG	13 VAC	13 VAC	13 VAC	13 VAC	13 VAC	14 VAC	14 VAC	14 VAC	
10AWG	12 VAC	13 VAC	13 VAC	14 VAC	14 VAC				
12AWG	13 VAC	13 VAC	14 VAC						

ELECTRICAL REQUIREMENTS

The Electronic Ignition System operated on 12 Volts power ONLY
DO NOT power using 110 Volts - Damage WILL RESULT

Acceptable Input Voltages to Supplied 12 Volt AC Control Panel:

110/120 VAC 60HZ

- Low voltage safety isolation transformer for swimming pool/spa and submersible fixtures in rainproof enclosure
- Mount at least 1ft. above ground with arrows facing up (arrows shown on the front of the control panel cover)
- Not for use with dimmers
- Use copper conductors only. Connect grounding conductors to equipment ground
- Connect conductors from light to transformer output selection as show on diagram
- Do not connect two or more transformer in paralel
- For field connections, use wires suitable for at least 194°F (90°C)

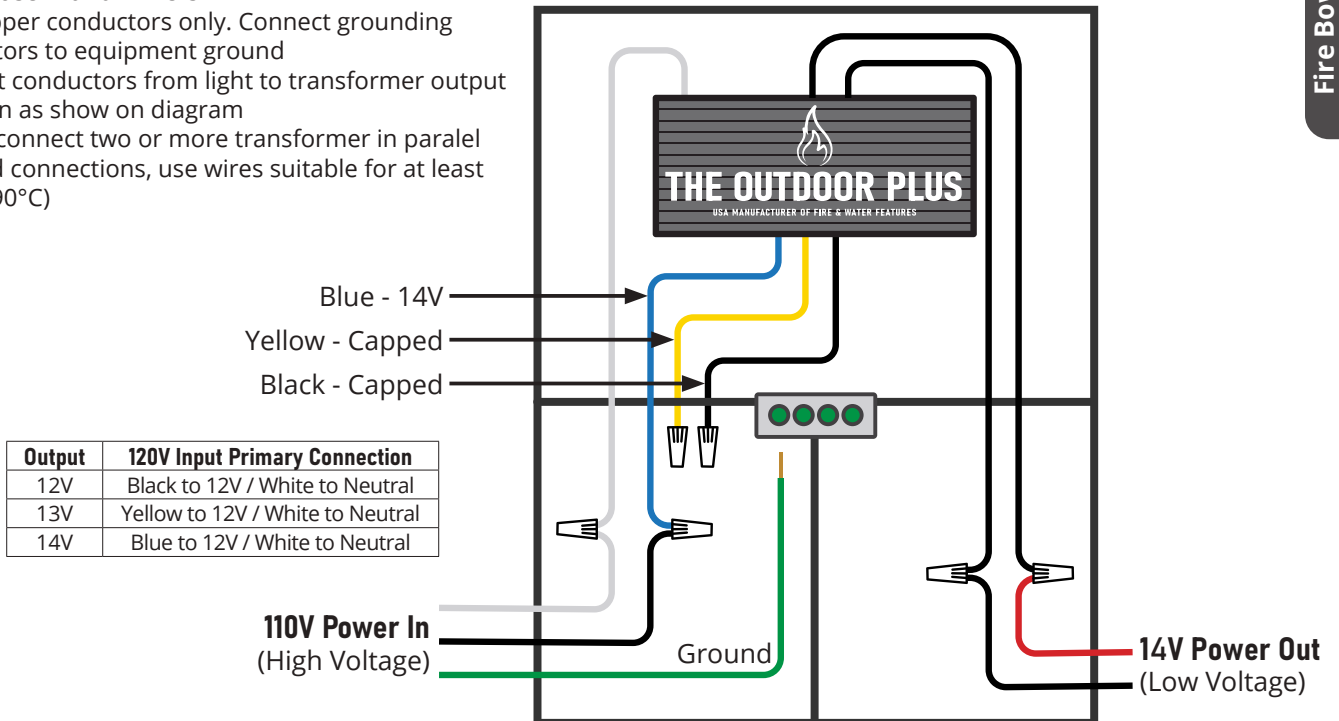

Fire Bowl
12VAC



12VAC FIRE BOWL INSTALLATION

RUNNING GAS LINES

- The gas piping shall be installed underground between to each fire bowl.
The piping shall be reduced to 1/2" NPT at each bowl.
- To eliminate unnecessary pressure drop, ensure the pipe length and amount of elbows used is minimized.
- Yellow corrugated flex lines should not be used. ONLY use stainless steel whistle free hoses
- Gas lines should be centered in the middle of the column.

KEY VALVE HIGHLY RECOMMENDED TO ADJUST HEIGHT OF FLAME OF EACH INDIVIDUAL FIRE FEATURE

Key Valve - OPT-256

Key Valve & Installation onto bowl - OPT-KVI

KEY VALVES SOLD SEPERATLEY

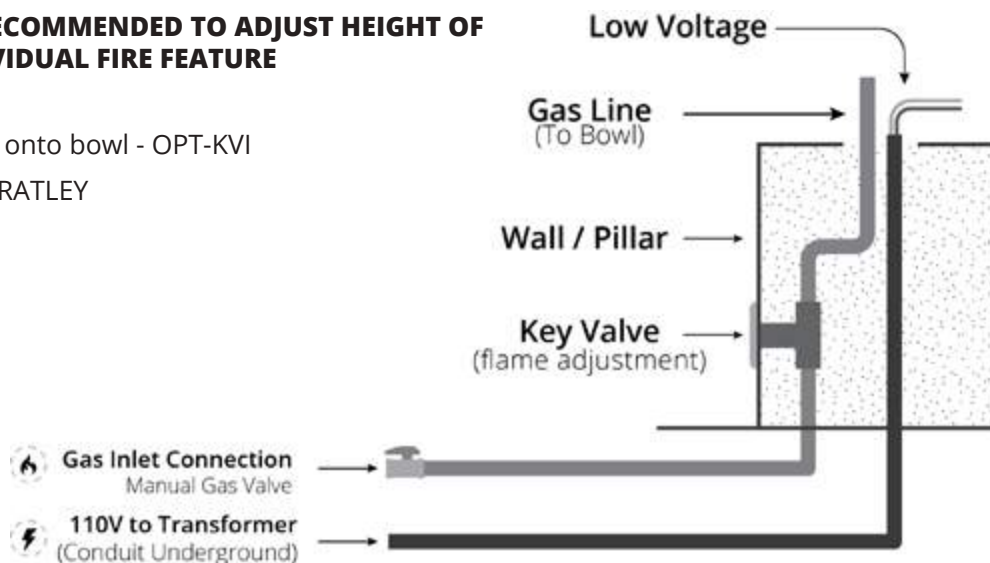

MOUNTING ON PILLAR/WALL

- Secure mounting bracket to mounting location with anchors rated for material being affixed. (Anchors not supplied by The Outdoor Plus.)
- Avoid grout seams when installing anchors
- Center cutout hole must be no larger than 4" inches square or diameter. Any larger and the mounting bracket will not have enough area to be properly secured.
- Use bracket to locate and mark the hole location.
- Do NOT kink or sharply bend any of the stainless steel gas lines.
- Do NOT use yellow corrugated gas lines.
- Key Valves near the bowl are recommended for flame adjustment.

Fire Bowl
12VAC

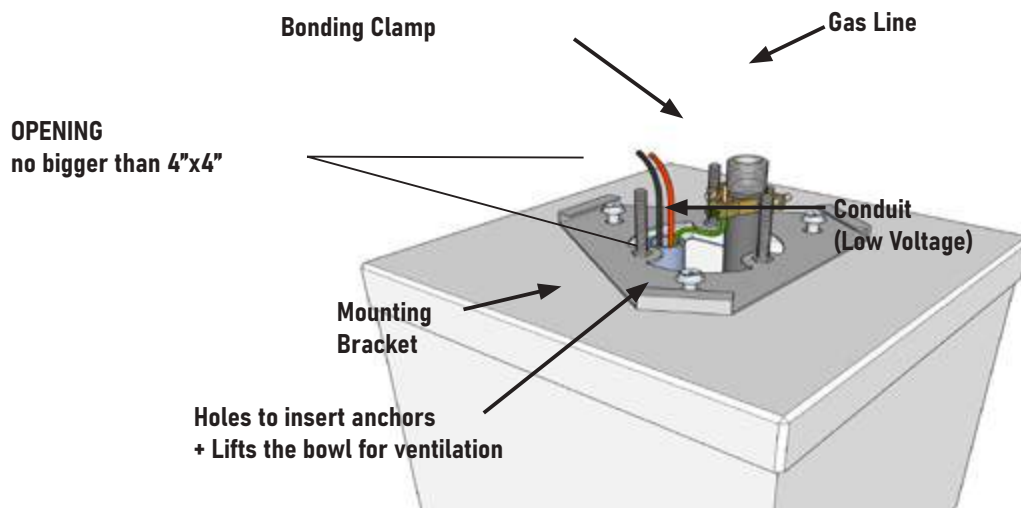

12VAC FIRE BOWL INSTALLATION



INSTALLATION OF FIRE BOWL

WARNING: We suggest that our products be installed by professionals that are locally licensed by the authority having jurisdiction in gas piping.

WARNING: We suggest that our products be serviced annually by a professional certified in the US by the National Fireplace Institute (NFI) as NFI Gas Specialists.

WARNING: Confirm this appliance is built for gas used – natural gas or propane. Do not use natural gas appliance with propane. Do not use propane appliance with natural gas.

WARNING: To prevent damage, unhook fire bowl from gas supply for pressure leak tests.

WARNING: Fuel line sizing is the responsibility of the installer and must be able to supply the stated maximum BTU for the product.

WARNING: Burn Testing- It is the responsibility of the qualified installer to test for gas leaks at all connections.

WARNING: When filling the pan with lava rock and/or decorative glass, follow directions on the following page

WARNING: Gas Plumbing Connections: Use only joint compound or tape that is resistant to all gases. Apply joint compound to all male pipe fittings only- do not use joint compound onto flared/tapered fittings. Be sure to tighten every joint securely.

WARNING: For systems with an extended or detached valve box the area in which the valve box is installed must conform with all installation requirements to include but not limited to location, construction, venting and local codes. Failure to do so may result in personal injury property damage or explosion.

WARRANTY REQUIREMENT: Warranty is void if product is altered.

- Plan your project well in advance to comply with all instruction and codes and allow for access and serviceability of the product.
- Purge gas lines of air.
- Perform all leak test with leak detector or leak reactant.
- Verify correct gas type and pressure.
- Perform leak test on main gas supply. Repair leaks as necessary.
- Shut Off Gas Supply and Power to fire-pit.
- Connect fire-pit to main gas supply.
- Turn on gas supply and perform leak test on all inlet connections. Repair as needed.
- Position fire bowl safely with access to all gas connections for testing.
- Light fire bowl. It may take several cycles to purge air from the lines.
- Once fire bowl is lit perform leak test on all gas connections. Repair as needed.
- Turn off fire bowl and allow to cool.
- Apply media
- Turn on fire bowl again and perform leak test with media correctly installed. If gas leak is detected verify correct media application and repair as needed.
- If key valve is installed, adjust flame to desired height. (Never alter the product configuration)
- Set fire bowl in properly constructed enclosure
- Verify correct operation and lighting.
- Review safety manual with end user and instruct not to change/ modify fire bowl or media.
- Leave manual with end user.

Component Overview

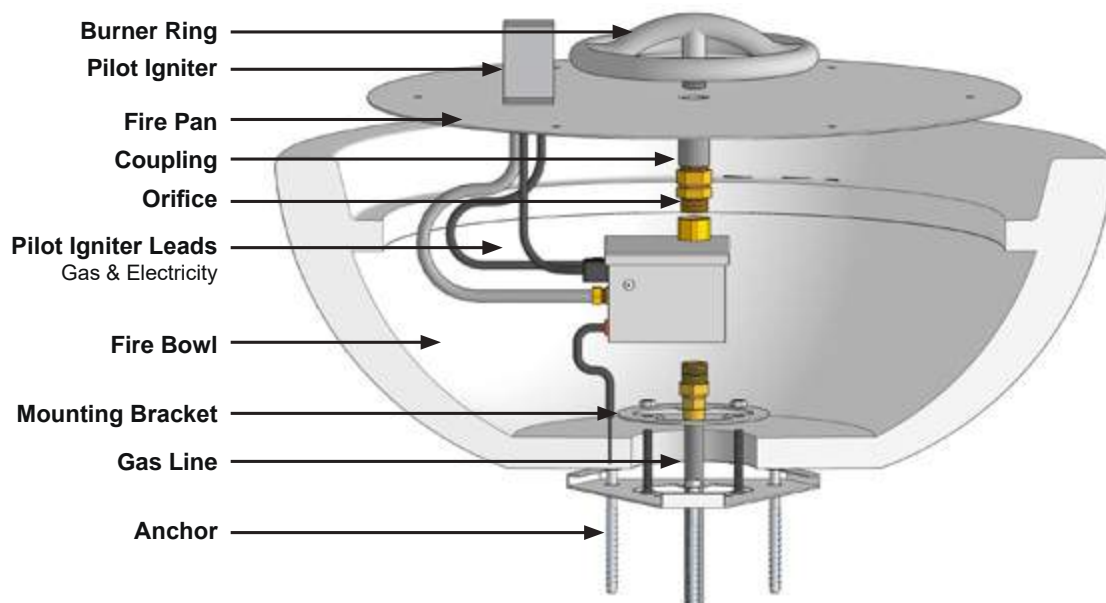

Fire Bowl
12VAC



12VAC FIRE BOWL INSTALLATION

INSTALLATIONS OF ELECTRONIC IGNITION SYSTEM

1. There is a bowl with both a gas riser and the electrical conduit with low voltage wires stubbed up inside the bowl. It is preferred to stub the gas riser centered in order to ensure the fire ring is centered in the bowl once installation is complete. (See diagram 1)

NOTE: Do NOT seal the bottom of the bowl. Drainage and Ventilation MUST be provided in the bowl. Use the mounting bracket provided to ensure ventilation and drainage

2. Apply pipe dope/plumber's tape to the gas stub and thread the box onto the gas riser (see diagram 2)

NOTE: Ensure the valve is upright. The coupling should be facing up and the gas should be threaded from the bottom of the valve box

NOTE: Leak Test - it is highly recommended to perform a gas leak test at this point in the install. Turn on the gas supply and then, using a soapy water solution spray the bottom of the Electronic Valve where it is connected to the gas line to ensure no leaks exist.

3. Diagram 3 shows the black and red wires protruding from the valve box have been connected to the low voltage wires from the electrical conduit using appropriate sized wire nuts.

NOTE: It is not required but it is recommended to fill the wire nuts with either dielectric grease or silicone prior to installing the wire nut. This will ensure a weatherproof electrical connection.

4. On the side of the Electronic Valve there are two connections for the Pilot Burner Assembly. The white 'quick connect' is the electrical connection and the brass plumbing fitting is the gas connection. There is a label next to these connections, "Attach Pilot Burner Here".

5. Diagram 4 shows the Electronic Valve after the Pilot Burner Assembly has been connected.

NOTE: The electrical connection for the Pilot Burner is a shaped connection thereby ensuring it can only be connected the correct way.

On one side of the box's connection, they will be two "ears" coming out of the connection. On the pilot, the electrical connection will have the same, black connection. There is a locking clip on the quick connect that will 'lock' the connection in place. To ensure a secure connection, make sure you hear a "Click" when inserting it .



Diagram 1



Diagram 2



Diagram 3



Diagram 4

Fire Bowl
12VAC



Electrical Connection on the end of the pilot igniter



Electrical Connection on the System

12VAC FIRE BOWL INSTALLATION



6a. See diagram 5. When installing the fire ring for natural gas applications, a brass orifice will be installed between the system and the fire ring. Apply pipe dope to both ends of orifice and install, along with a coupling.

6B. See diagram 6. When installing the fire ring for propane applications, a brass "Air Mixer" will be installed between the system and the fire ring. Apply pipe dope to both ends of the Air Mixer and install, along with a coupling. This will create a space between the burner and the air mixer that prevents backfire.

NOTE: Air mixer MUST be installed such that the holes are facing down.

7. Lower the stainless steel pan and insert the burner's nipple through the center hole. The holes will be facing up but this is okay as the burners have drainage holes on their underside.

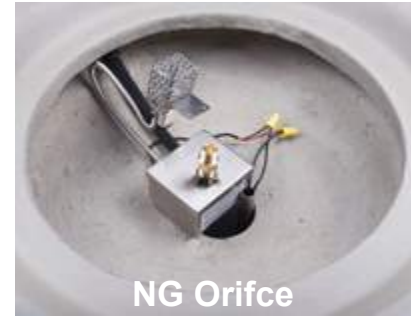
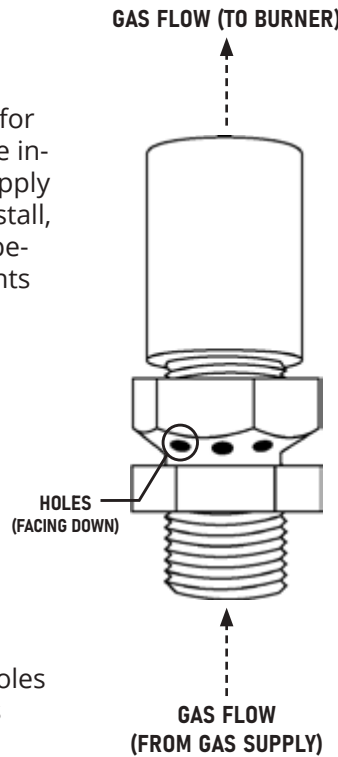

NG Orifice

Diagram 5



LP Orifice

Diagram 6

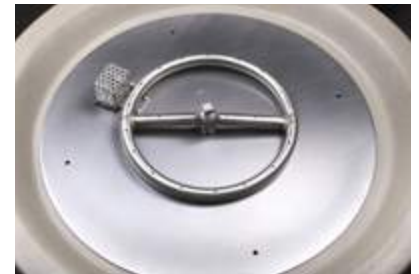

PROPERLY INSTALLED ELECTRONIC FIRE BOWL

Natural Gas

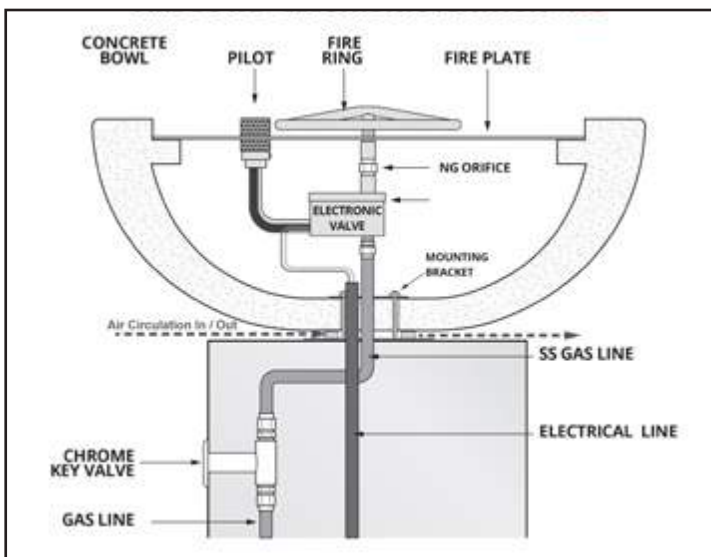

Liquid Propane

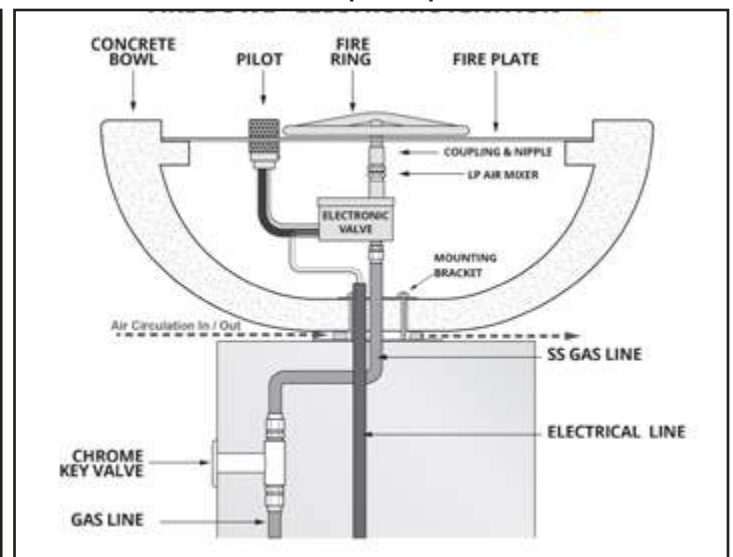

Fire Bowl
12VAC



12VAC FIRE BOWL INSTALLATION

ACCEPTABLE MEDIA FOR FIRE FEATURES

WARNING: Do not use any other material as filler/topping media inside fire features other than those listed below. Using improper media inside a fire feature could result in damage to property or injury to persons nearby due to media 'popping' or 'exploding' due to heat

LIST OF ACCEPTABLE MEDIA FOR FIRE FEATURES:

Fire Rated Lava Rock (or other Igneous Rock), Fire glass approved for use in fire features, Man-made stone for use in fire features (Reflective Material)

INSTALLATION NOTE: The use of media inside fire features is recommended because it enhances the look of the fire feature and improves its performance by forcing the gas emanating from the burner to mix as it passes through the media. This 'mixing' of gases creates an even flame throughout the feature and helps spread the flame from the Pilot Burner throughout the burner quicker than when there is no media. Recommended thickness of the media above the burner element is NO MORE than 2".



Lava Rock



Fire Approved Glass



Fire Approved Reflective Glass

INSTALLATION OF MEDIA IN FIRE FEATURES

There are several options when it comes to topping material for a fire feature; large lava chunks, fire glass and fire stones. In this example we are using 1" lava rock. You will need a layer that is 2" - 3" thick to properly cover the fire feature while at the same time allowing plenty of oxygen to mix with the gas coming from the fire ring. This lava rock is more expensive than the "filler" lava rock but is still fairly inexpensive and readily available in the BBQ section of most hardware stores.

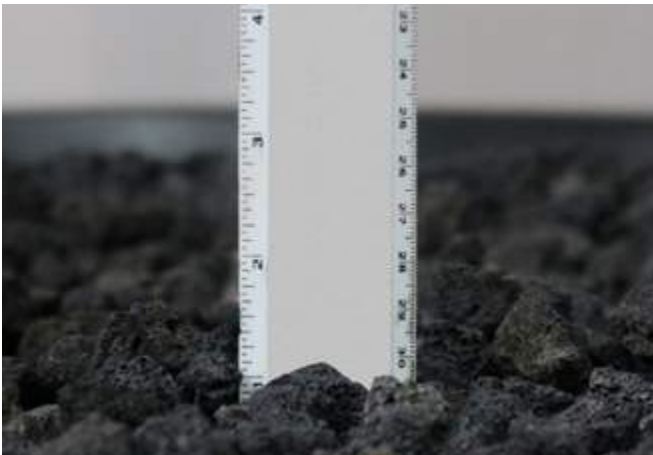

No more than 1" of burning media should cover the burner. Adding more may cause damage



Do NOT cover the top of the pilot.

- Covering the pilot will cut off air required for ignition.
- Covering the pilot will retain heat and cause the system to overheat and malfunction

Fire Bowl
12VAC



12VAC FIRE BOWL INSTALLATION

FIRE BOWL OPERATION

WARNING: Before use, be sure to test all gas connection for leaks. Do not use fire bowl if there is any evidence of leaking gas.

If leaking gas suspected, turn off the main gas supply and repair immediately

WARNING: Do not use the fire bowl if any part has been submerged under water.

Immediately call a qualified technician to inspect the fire bowl

WARNING: Never use any material that is non-porous and holds moisture such as gravel, pebbles, river rocks, etc.

This material, when heated, will cause moisture trapped inside to boil and fracture unexpectedly. This material is not sufficiently porous to allow heated steams to readily escape which can break and cause personal injury or damage

WARNING: solid fuels shall not be burned in the fire bowl. Leaves, sticks, wood, paper, clothing, food, should be kept away from the fire bowl. Fire bowl is not for cooking. Make sure that there is no vegetation or other objects over the top or sides of the fire bowl that could interfere with safe operation. See "Clearance from Combustibles" diagram at the end of this document.

WARNING: If lava rock is wet, allow fire bowl to burn for 45 prior to coming within 15 feet of the fire bowl.

WARRANTY REQUIREMENT: When not in use, the fire bowl must be covered.

IMPORTANT: INITIAL START-UP: It may be necessary to purge Air in the Gas Lines after system installation.

FIRE FEATURE START UP

1. Prior to turning appliance on visually inspect fire feature to ensure debris such as leaves or other combustible material has not collected inside the feature which could burn and emit embers once the fire feature is turned on. Also ensure any person standing close to the fire feature is aware you will be turning the fire feature on prior to actually turning it on.

2. Turn fire feature on by turning on the electrical device used to power the fire feature.

Sequence of Operation during Ignition

Power is applied

Hot Surface Igniter (Glow Plug) becomes hot and 4 seconds later the Pilot Gas Valve opens

Within 10 seconds of power application Pilot Flame should be visible (at night only)

Within 10 seconds of Pilot Flame Ignition burner (fire ring/burner bar) should ignite

FIRE FEATURE SHUTDOWN

Turn fire feature off by turning off the electrical device used to initially power the fire feature



WARNING:
If fire feature fails to turn off completely (small flames still visible)
Turn off gas supply using the manual gas shutoff.



Fire Bowl
12VAC

MAINTENANCE

WARNING: Maintenance should be done by a qualified service technician. The appliance should be inspected before use and at least annually by a qualified service technician.

WARNING: Ensure gas and power are shut off and appliance is cool before servicing.

WARNING: Any guard or protective device removed for servicing must be replaced prior to operation.

Prior to Each Use

1. Inspect for debris in Fire Feature – remove debris prior to use

Semi-Annually

1. Visually inspect Pilot Burner for debris/insect infestation (spider webs)

2. Visually inspect burner holes for debris/insect infestation

3. Clean either of the above as necessary using compressed air.

Annually

1. Visually inspect Pilot Burner for excess corrosion due to heat and moisture.

2. Turn fire feature on to ensure proper operation.



12VAC FIRE BOWL INSTALLATION

TROUBLE SHOOTING

I installed the Electronic Ignition System, turned it on and nothing happened

When this occurs it is usually due to an electrical wiring / power issue. Check all your electrical connections thoroughly to ensure all wires at the transformer and inside the fire feature are connected properly. If it appears all wiring is connected properly, disconnect the wires at the fire feature, attach a Multimeter to the wires to confirm a minimum of 12 volts when the fire feature is turned on. If you determine that you do not have a minimum of 12 volts at the fire feature conduct the same test at the transformer to ensure the transformer is in fact producing a minimum of 12 volts. If you do have a minimum of 12 volts at the fire feature contact us for further assistance.

I installed the Electronic Ignition System, turned it on and I can see the glow plug glowing orange and I can hear gas flowing but it will not ignite.

There are two possible causes to this problem; Air in the Gas Line or not enough Electrical Current to the fire feature.

Air in the Gas Line - If a new gas line was installed and the air was never purged from it prior to installing the Electronic Ignition System then it may take several times of turning the fire feature on and off before the air is purged from the gas line. Here is how our system works; after you turn it on the glow plug will come on first followed by the Pilot Gas Valve opening 4 seconds later. For the next 180 seconds (3 minutes) the glow plug will cycle on and off every 30 seconds while the Pilot Gas Valve will remain on the entire time. Therefore if you are attempting to purge air from the gas line, turn the system on and leave it on for approximately 3 minutes. Then turn it off and then back on (no need to wait to turn it back on). Let the system run for another 3 minutes. Usually when purging air from a new gas line you will need to cycle the power several times as described above before gas begins to flow. If at any point you smell gas but still don't have ignition, attempt to light the pilot flame with a hand-held lighter. If the flame ignites when you light it by hand, go to the section below, "Electrical Current".

Electrical Current - If you have determined that air in the gas line is not the problem then most likely the failure to ignite is due to the fact the glow plug is not getting hot enough to ignite the gas. The reason a glow plug will not get hot enough is due to the fact it is not getting enough amps. Often times when troubleshooting electricians will check the electrical power and when they see they have a minimum of 12 volts they think everything is fine electrically so there must be a problem with the Electronic Ignition System. The problem is not due to the volts but rather the amps. The number of amps reaching the fire feature is heavily dependent on the gauge wire used between the transformer and the fire feature. Our Install Instructions require no less than 12 gauge wire be run for all fire features. Often times we learn that in many cases less than 12 gauge wire has been used and herein lies the cause of the problem.

Here is how you check to determine if enough Electrical Current (amps) are getting to the fire feature:

1. CAUTION: Turn off the gas supply prior to the next step.
2. Using a clamp on ammeter, clamp the ammeter around one of the wires providing power to the Electronic Ignition System.
3. Turn the fire feature on.
4. The amps you should see will range between 1.4 to 1.6 amps initially. Four seconds after being turned on the amps will jump to approximately 2.0 amps.

If you do not see the amps listed above AND the wire gauge used was less than 12 gauge wire – change the wiring. Otherwise contact us for further assistance.

I turned the Fire Feature off but I still see small flames emanating from the fire feature.

Turn the fire feature on, let the main fire ring light and then turn it off again – do this several times. Small pieces of debris from the gas line can get caught in the main or pilot valve thereby preventing it from closing all the way. This will sometimes happen with a new gas line. By cycling power you can often times dislodge the debris. If cycling power does not rectify the problem, turn the gas off using the manual gas shutoff and contact us for further assistance.

REPLACEMENT PARTS



TOP-500PI
Plot Igniter Assembly



TOP-12VCP
12V Control Panel



OPT-INBR
Installation Bracket



OPT-158-8
8" Burner

OPT-159
12" Burner

CLEARANCE FROM COMBUSTIBLES DIAGRAM

THIS DIAGRAM APPLIES TO ANY GAS FIRE FEATURE

Installation - We suggest that our products be installed by professionals that are locally licensed by the authority having jurisdiction in gas piping

Flooring - All fire pits and fire features must be installed on non-combustible flooring. If the fire feature is installed on a combustible floor, such as wood decking, a non-combustible floor paneling **MUST** be properly installed underneath.

Service - We suggest that our products be serviced by a professional certified in the US by the National Fireplace Institute (NFI) as NFI Gas Specialists

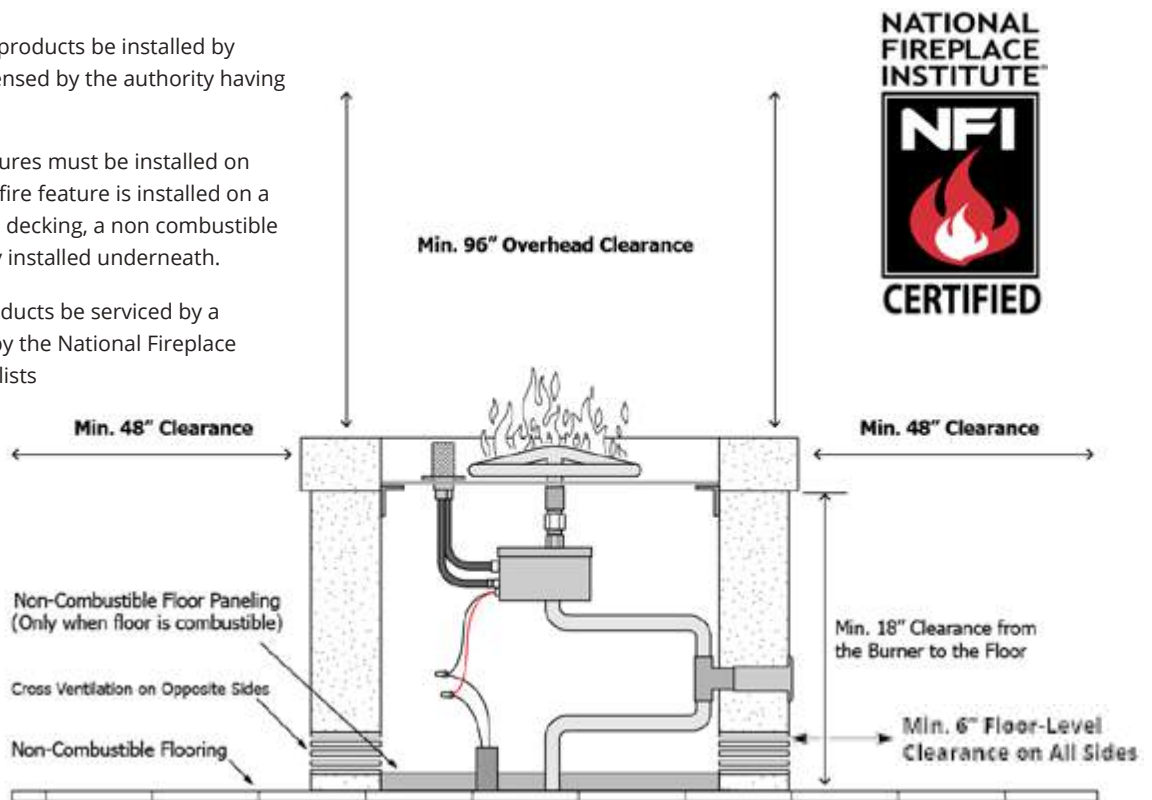

LIMITED WARRANTY

The Outdoor Plus Company (TOP) warrants all bowls against manufacturing defects that prevent safe and correct function as follows:

- Electronics, Gas Valve, & Pilot Assembly: Commercial-6mos; Residential- 1 yr.
- Stainless Steel Pan, Fire Ring, & Valve Box: Commercial-1yr.; Residential 3yrs.

- This commences from the date of original sale / shipment from The Outdoor Plus.

- This warranty is for parts and in-house (TOP) labor. The defective product must be sent back to TOP with a Return Merchandise Authorization (RMA) issued by TOP for that specific product and any other additional information for the nature of the defect or warranty claim.

- The warranty does not cover items that have been damaged by overheating, modification, abuse, or improper storage. Also any labor involving installation or maintenance with the unit is not covered.

- This warranty excludes claims for consequential, indirect-collateral expenses arising from product defects or warranty recovery.