

UK Installation instructions

DE Montageanleitung

CZ Montážní návod

DK Monteringsvejledning

EE Paigaldusjuhend

FI Asennusohje

FR Notice de montage

HU Szerelési útmutató

IT Istruzioni di montaggio

LT Montavimo Instrukcijos

LV Instalācijas instrukcija

NO Monteringsanvisning

PL Instrukcja montażu

SE Installationsanvisning

RU ИНСТРУКЦИЯ ПО МОНТАЖУ

TYPE : RAZE ARCHI SMALL

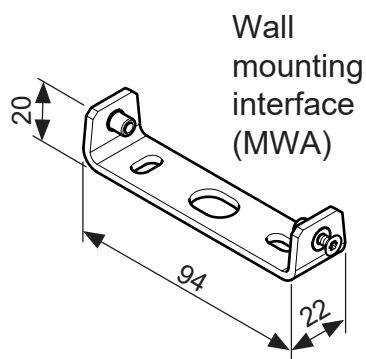
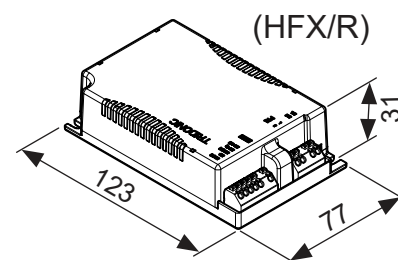
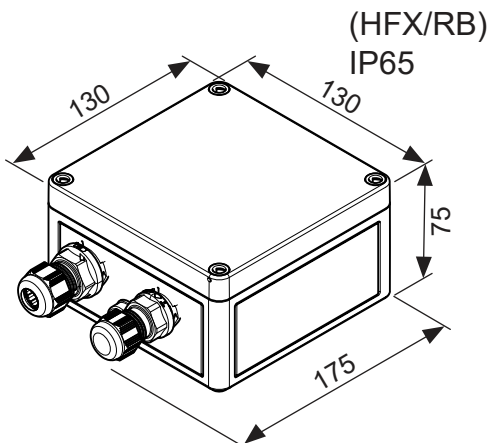
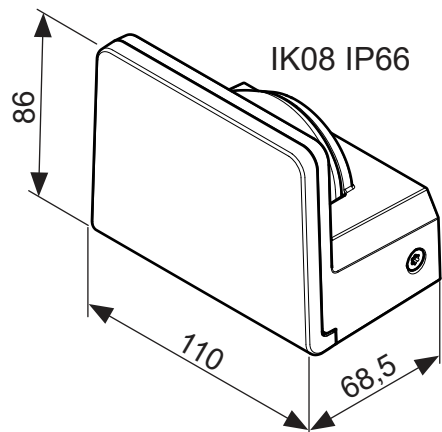

RAZE ARCHI SMALL	
	(kg)
MWA	0,56
MSF	0,61
HFX/R	0,22
HFX/RB	0,7

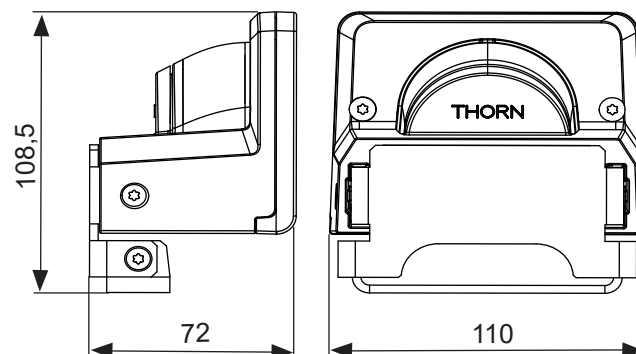
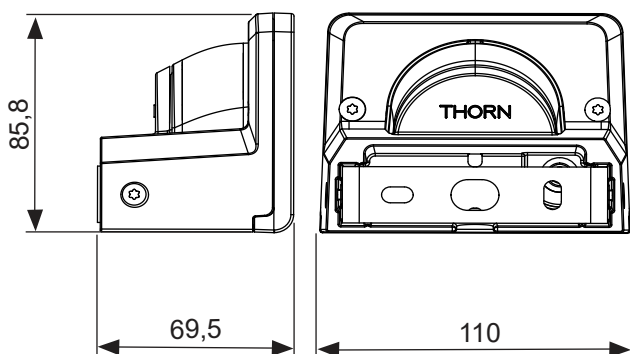
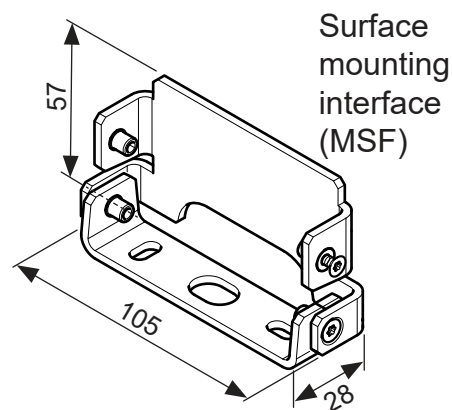

If the external flexible cable or cord of this luminaire is damaged, it shall be exclusively replaced by the manufacturer or his service agent or a similar qualified person in order to avoid any hazard.



CLASS II

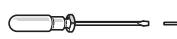

T20 creux / Hollow

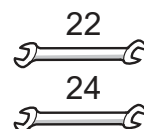
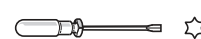

1 WALL MOUNTING (MWA)

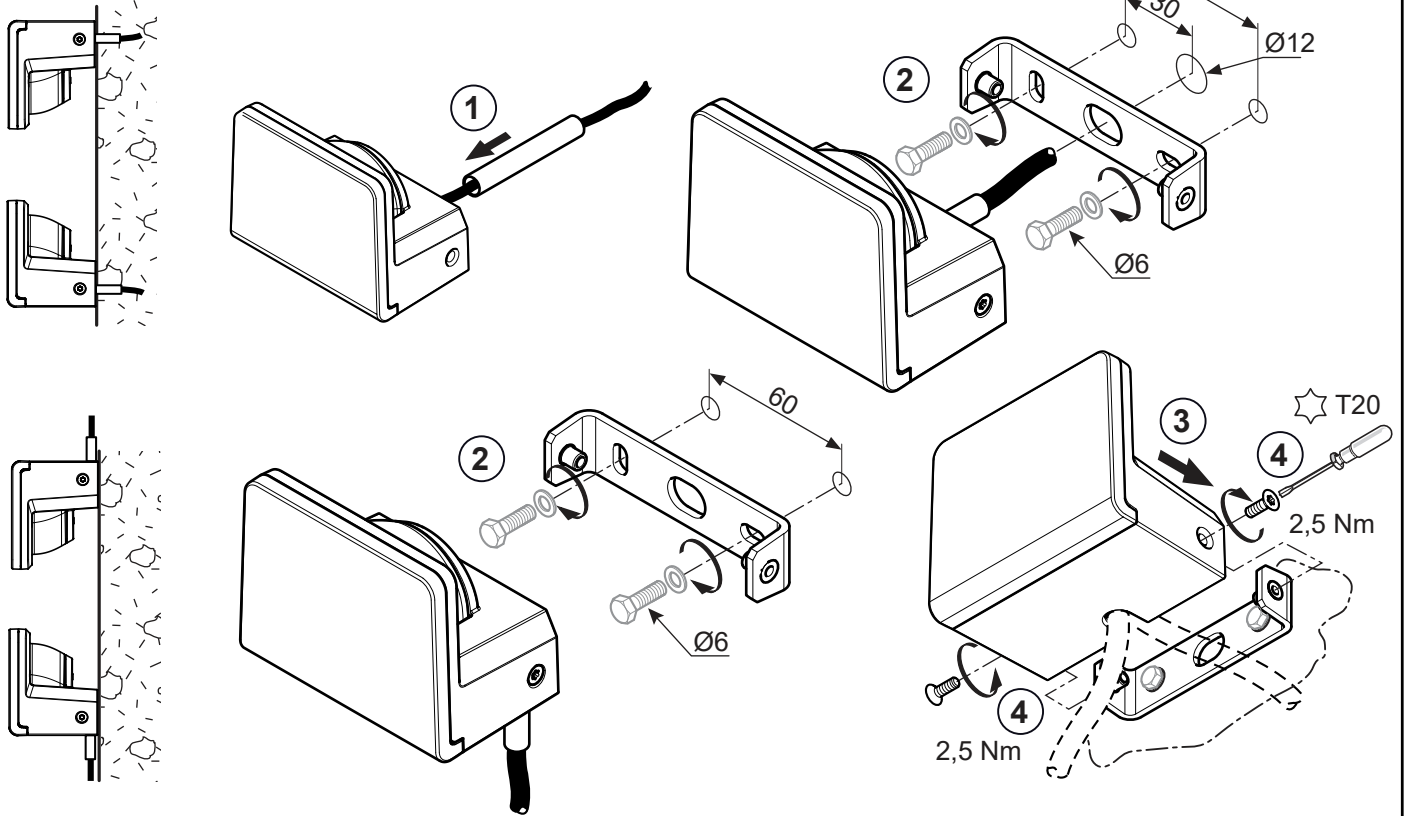

2 SURFACE MOUNTING (MSF)

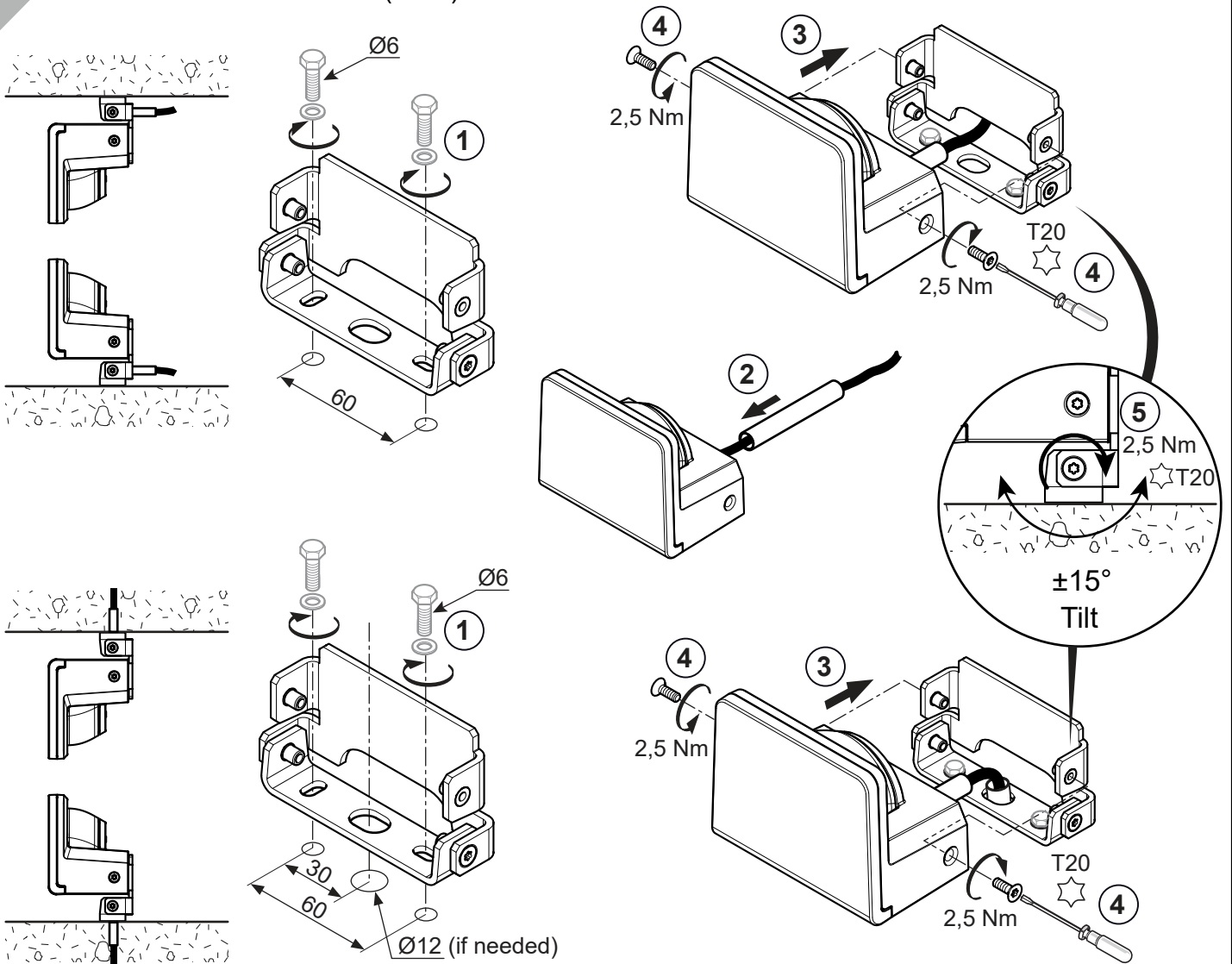

3

HFX/RB

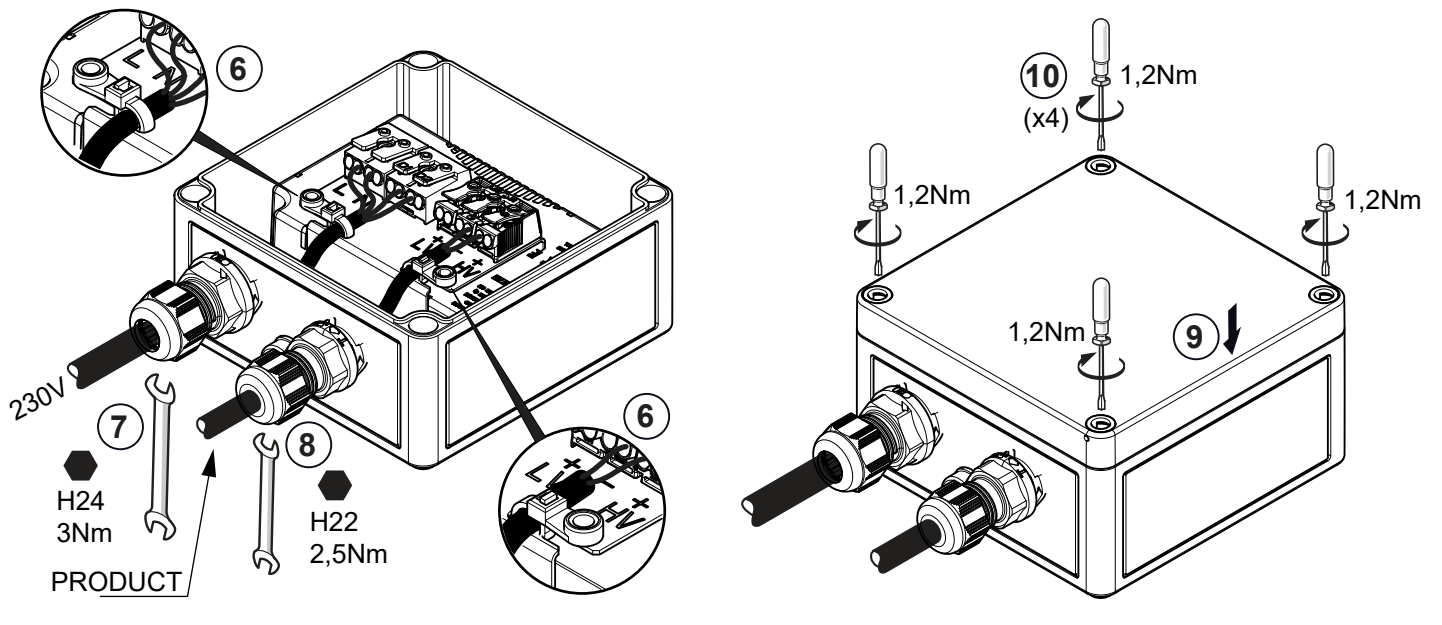
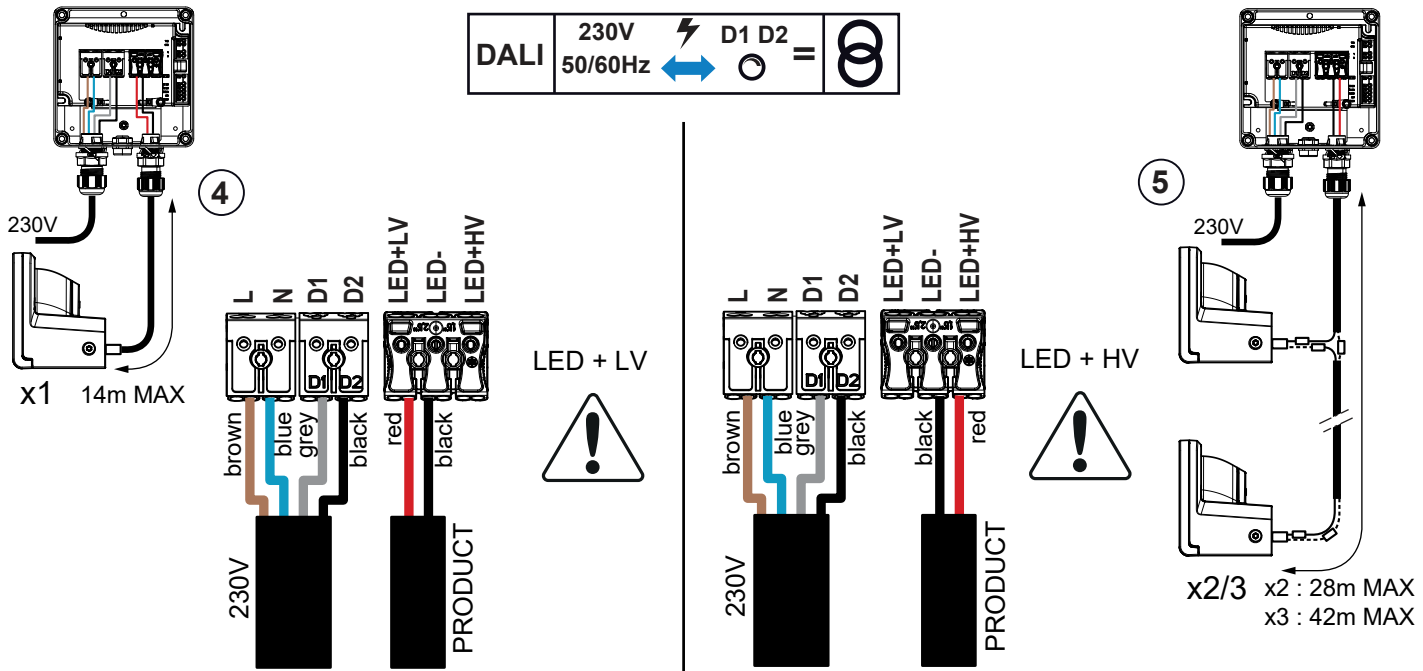
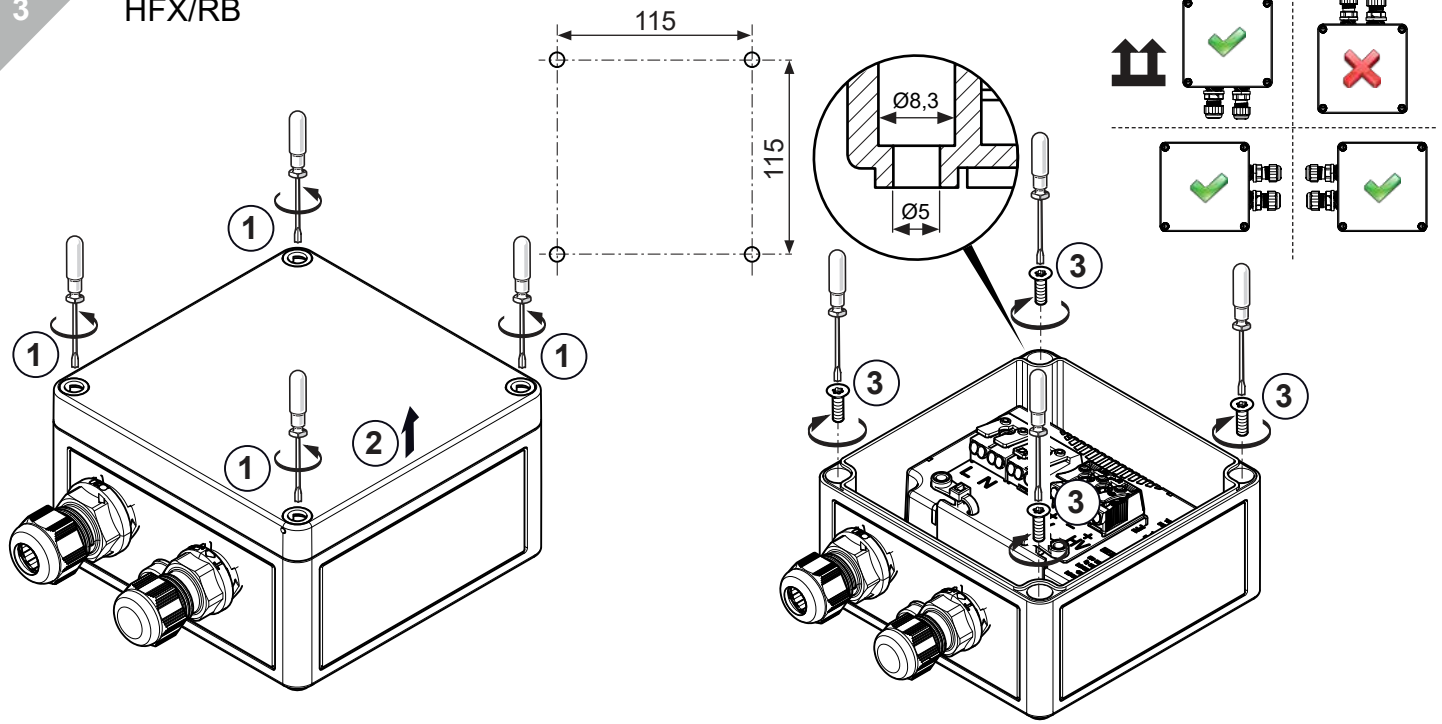

4

HFX/R

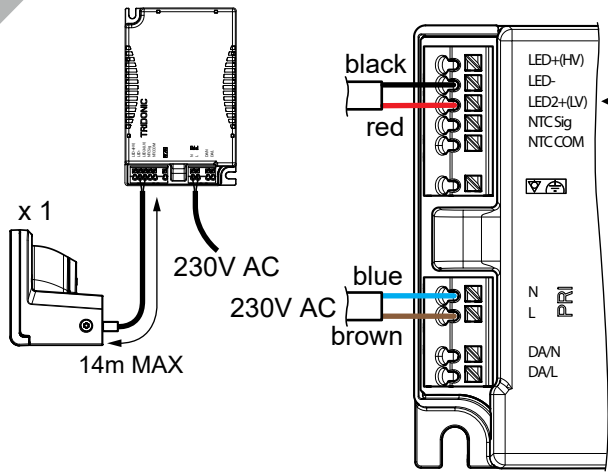

Driver TRIDONIC 87500883

Uout-Min = 12V-DC

Uout-Max = 120V-DC

Insulation = SELV

LED+LV

BOX IP65 (Not delivered)

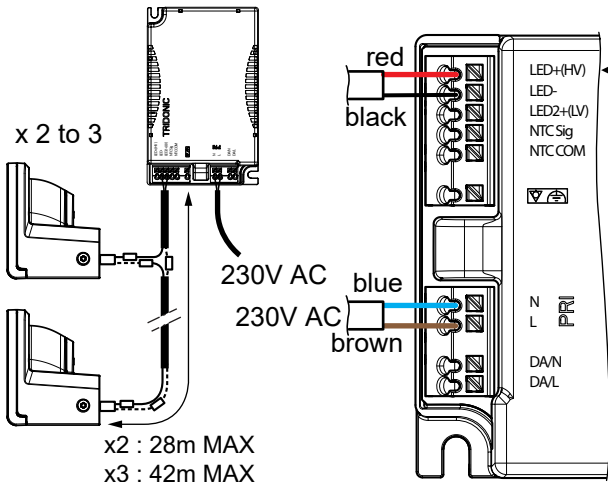
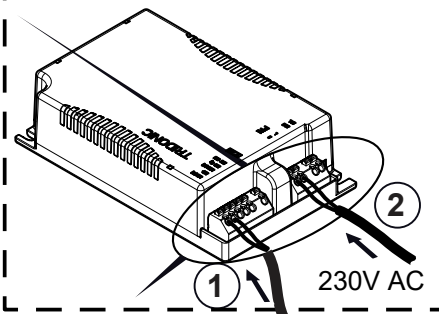

LED+HV

5

Recommended cable

H07RN-F

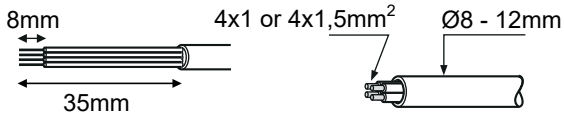

EVERY 6 MONTHS

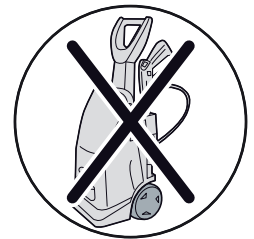
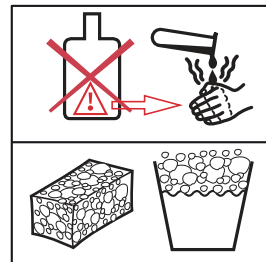

FRANCAIS

- Remplacer toute protection fissurée.
- Les luminaires classe II doivent être installés de façon à ce que la partie métallique ne soit pas en contact avec l'installation électrique connectée à la terre.

ATTENTION: Les luminaires classe I doivent être reliés à la terre.

- Ce luminaire fonctionne à une tension nominale qui doit être coupée avant toute intervention sur l'appareillage.
- Toute modification de cet appareil est interdite.
- Respecter la distance minimale par rapport aux objets éclairés définie par ce sigle.

SVERIGE

- Ersätta alla spräckta skyddsplåtar.
- Klass II armaturer måste installeras så att nakna metalldelar i armaturen inte är i kontakt med någon elektrisk installation, kopplad till en skyddledare.

WARNING: Klass I armaturer måste vara jordade.

- Denna armatur fungerar med högspänning som måste vara fränslagen före ingripande i driftdonen.
- Alla ändringar i denna armatur är förbjuden.

ITALIANO

- Sostituire sempre tutte le protezioni danneggiate.
- Gli apparecchi in classe II devono essere installati in modo che le parti metalliche non siano in contatto con apparati elettrici collegati a terra.

ATTENZIONE: Gli apparecchi in class I devono essere collegati a terra.

- Questo apparecchio funziona a tensione nominale, questa deve essere interrotta prima di ogni intervento sul gruppo di alimentazione.
- Ogni modifica dell' apparecchio è proibita.

ENGLISH

- Replace any cracked protective shield.
- Class II luminaires must be installed so that exposed metal work of the luminaire is not in contact with any part of the electrical installation connected to a protective conductor.

WARNING: Class I luminaires must be earthed.

- This luminaire operates at mains voltage which must be switched off before intervention in control gear.
- Any modification to this luminaire is forbidden.
- Lighted objects nearer than the minimal distance in the is forbidden.

DEUTSCH

- Ersetze jede gebrochene Schutzscheibe.
- Schutzklasse II Leuchten müssen so installiert werden, daß berührbare Metallteile nicht mit einem, an dem Schutzleiter angeschlossenen Teil der elektrischen Installation in Kontakt kommen können.
- ACHTUNG:** Schutzklasse I Leuchten müssen geerdet sein.
- Diese Leuchte wird mit Netzspannung betrieben. Bevor Eingriffe am Vorschaltgerät vorgenommen werden sowie vor Wartung und Installation, ist die Versorgungsspannung abzuschalten.
- Jede Änderung an dieser Leuchte ist verboten.

SUOMI

- Rikkoontunut suojalasi vaihdettava välittömästi uuteen vastaavaan.
- Asennettaessa suojausluokan II valaisinta on peruseristetyin johdon ja koskettavien metalliosien välinen kosketus tehokkaasti eristettävä.
- VAROITUS:** Suojausluokan I valaisin täytyy maadoittaa.
- Verkköjännite on kytkettävä pois ennen valaisimen huoltotoimenpiteitä.
- Valaisimen rakennetta ei saa muuttaa.