

12v Diesel Heater

Instructions for installation and maintenance.

Thank you for choosing the air heater products produced by our company among many products. Your choice will prove to be wise and correct.

Main technical parameters and application fields

Thank you for choosing among many products. air heaters manufactured by our comp

Implementation criteria: Q/HJL01-2015

Model number: Air heater 3KW-5KW

Service voltage: 12V

Fuel: diesel oil

Catalogue -

Summary

- 、 Main technical parameters and applications

(1) Technical parameter table

(2) Applicable field

(3) Product Size

Installation and use considerations

- (1) Installation site for truck internal heating unit
- (2) Installation position of main engine for internal heaters of minivans and medium passenger cars

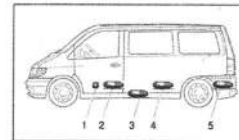
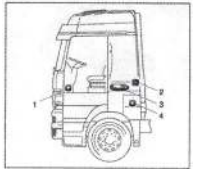

- (2) Installation position of main engine of heater in RV



- (3) place of installation of the central block of the heater of the excavator cabin

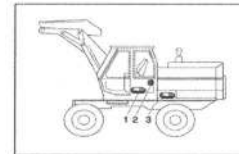

heater main engine for electric vehicle

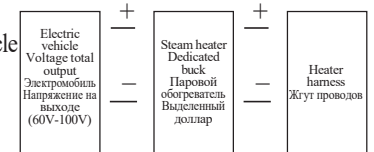

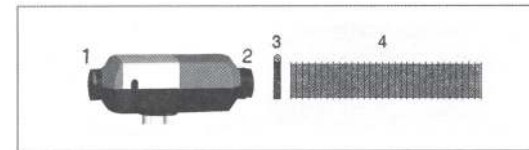

(10)Installation of heating air ducts for heaters

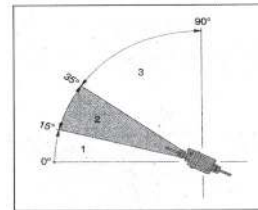

(11) Installing the metering pump and precautions

(12) Oil Extractor Installation and Precautions

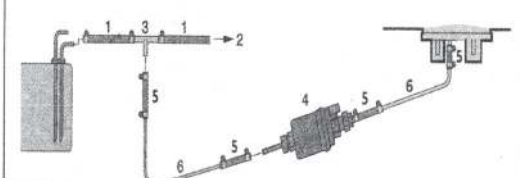

- 1. Automobile fuel tank
- 2.2. Leading to automobile engine oil pump
- 3. T-type tee
- 4. Metering oil pump
- 5. Connecting hose
- 6. Tubing

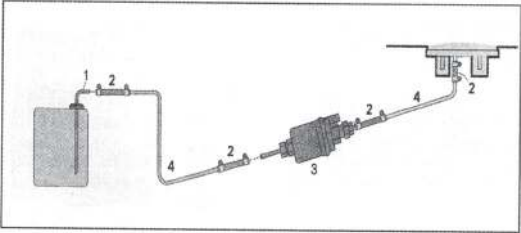

- 1. Oil extractor
- 2. Connecting hose
- 3. Metering oil pump
- 4. Oil pipe

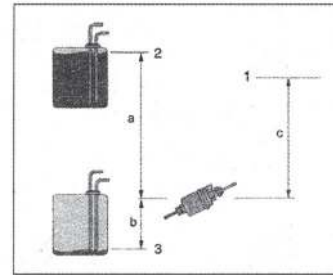

- 1.Heater connector
 - 2.Maximum oil pressure height
 - 3.Minimum fuel content
- Precautions:
 The vertical height below the oil pump installation tank, a = up to 3 meters
 b.The vertical height above the oil pump installation tank, b = up to 1 meter
 c.The vertical height of the oil pump to the heater (the oil pump should be installed below the heater) c= up to 1.5 meters

五、 maintenance and repair

六、 Manual operation, automatic control and digital display function display

A、 Instructions for the use of knob control switches

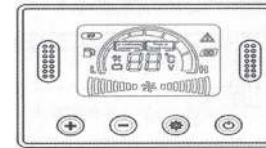

Functional status when each function icon is lit (see figure)

Circuit diagram

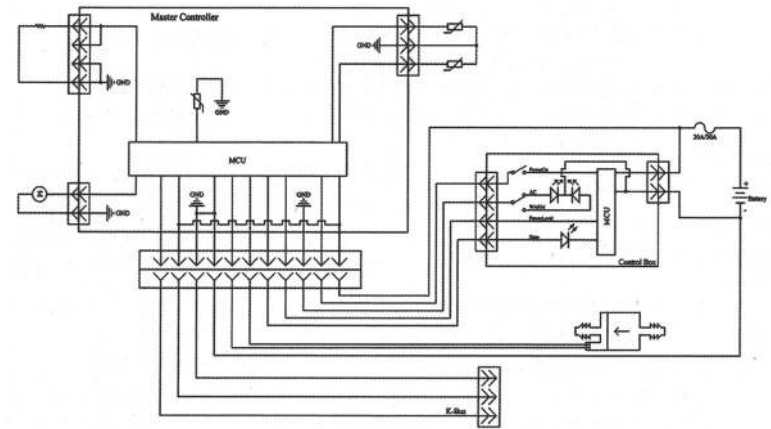

B、Instructions for the use of digital screen switch control
七、Fault analysis and troubleshooting measures

八、Regulations on warranty of after-sales service

一、summary

The heating fuel parking heater is a kind of device which uses on-board battery power supply and vehicle diesel fuel as fuel. Based on the principle of combustion heat transfer, the vehicle driver can be heated by air and defrosted by windshield.

The heater has two operating modes: manual heating and automatic air conditioning, flexibility in application to various heating needs. Based on the addition of diesel with compound winter marking, the collector can work stably in an environment above -40 degrees Celsius.

Main technical parameters and applications

(1) Technical parameter table

Heater model	Air heater 3KW	Air heater 5KW
heating medium	Air	Air
Heating power	1500-3000	160-245
Hot air flow rate (M3/H)	160-220	Air
Fuel consumption (L/H)	0.22-0.36	0.22-0.39
Operation power consumption (w)	19-43	19-48
rated voltage Номинальное	12v/24v/60v	12v/24v/60v
Undervoltage protection limit	21.5v	21.5v

Protection limit surge protection		32v		32vv	
ambient temperature a	running temperature	storage temperature	works	Not running time	
Calorifier	-40to +70	-55 to+105	-40to+70	-40to+85	
Dose oil pump	-40to+50	-55to+105	-40to+50	-40to+105	
Hot air intake temperature		Up to + 40		Up to + 40	
Mainframe weight		About 4.5 kg.		About 5 kilos	

(2) Applicable field:

The warm parking heaters produced by the company can be independently applied to the following spaces that need to be heated without starting the vehicle: suitable for the cockpit heating, defrosting and space heating requirements of various vehicles, such as cars, trailers, RV, agricultural vehicles, electric vehicles, ships, engineering vehicles and storerooms.

(3) product size:

Warning:the heater should not be heated for a long time, the living room, garage and other confined spaces are prohibited to prevent carbon monoxide poison

Structure and working principle:

2. Installation and use considerations

Install the electric heater in the cab, or install the heater in the toolbox if it cannot be installed in the driving room (for vehicles that install the heater in the toolbox, note that there should be enough vents in the toolbox).

Installation position of main engine of heater in truck The heater is installed at the front end of the copilot's foot

1.The heater is installed on the rear wall of the cab 2.The heater is installed at the back of the driving seat

The heater is installed in the toolbox

(2) Installation position of main engine for internal heaters of minivans and medium passenger cars

1. The heater is installed at the front end of the copilot's foot

The heater is installed between the front driving and the auxiliary driving seat

The heater is installed on the floor of the cab

The heater is installed on the floor under the passenger seat

The heater is installed in the suitcase (note that there are enough vents in the suitcase)

Installation position of main engine of heater in RV

. 1. The heater is installed at the front end of the copilot's foot

2 The heater is installed between the front driving and the auxiliary driving seat

3 The heater is installed on the floor of the cab

4 The heater is installed in the suitcase (note that there are enough vents in the suitcase)

5 Heaters are installed below or inside the container (note that the container has enough vents)

(4) Installation position of main engine of heater in excavator cab

1 The heater is installed at the back of the driving seat

2 The heater is installed on the rear wall of the cab

3 The heater is installed in the box (it should be noted that there are enough vents in the box)

(5) Installation of heater main engine for electric vehicle

1 When the heater is installed in the 60v-100v electric vehicle, the voltage reducer should be installed.

2 The heater must not be directly connected to the EV voltage output.

3 When fetching electricity from an electric vehicle, it can not be connected to a single battery of an electric vehicle. When fetching electricity, it is necessary to collect electricity from the output end of the total voltage of the vehicle.

4 When the electric vehicle adopts the external fuel tank, the fuel tank should be placed in a safe position.

5 When using heaters for heating, ventilation should be kept in the heating space and ventilation should be carried out frequently.

driven vehicle Total voltage output (60v-100v)	Gas heating heater Special step-down device	Heater harness
--	--	----------------

(6) Allow installation angle range

As shown in the figure: the main use of normal angle to install the heater. According to different conditions, the heater can be tilted downwards in the direction of hot air when installed, and the tilt angle should not be more than 30 degrees, or around the long axis of the heater itself, the rotation installation angle should not be more than 90 degrees (the main reason is that the ignition oil supply device should ensure that it is in the upward position to prevent the danger of oil backflow; In addition, the exhaust pipe can not be installed beyond the horizontal position, in case

the remaining oil or water in the main engine can not be discharged properly to cause danger)!

Two-dimensional diagram of fixed heater main engine

According to the two-dimensional drawings in the position to be installed to process exhaust gas combustion air and tubing installation hole, the heater leg installation plane must be flat, in case of heater and installation surface gap, resulting in exhaust gas inhaled into the cab and cause carbon monoxide poisoning! Note: between the whole fuselage of the heater and the installation surface of the vehicle, ensure that there is enough space to prevent the fuselage of the top pressure heater, resulting in the

deformation of the fuselage during the use of the heater, resulting in danger!

(8) Installation of air intake duct assisted by heater

The mounting unit has a corrugated hose with an inner diameter of 25 mm. The minimum length of the combustion duct must not be less than 20 cm, depending on the installation. The combustion duct should not be longer than 1.5 m. The pipe is attached to the heater, and the other end is attached to the body using the bracket.

(7) Installation of exhaust device for heater

The installation assembly contains a exhaust pipe with an inner diameter of less than 25 mm and a length of 60 cm. Depending on the installation, the exhaust pipe can be shortened to 20 cm or lengthened to up to 1.5 m. One end of the exhaust pipe is fixed to the heater with a pipe card, and the other end is fixed to the car body with a bracket.

●Instructions for installation of exhaust devices :

●All parts of the exhaust device will be very hot throughout the process from the beginning of the heater to the shutdown. Therefore, please follow the installation instructions to install the exhaust device.

- The exhaust outlet must be located outside the vehicle.

The exhaust pipe shall not exceed the boundary of the side of the vehicle

The exhaust pipe should be tilted downward so that the condensate can be discharged

- Do not affect the function of vital components on the vehicle (be careful to maintain sufficient spacing, reference spacing 50 cm)

- Note that the exhaust pipe should be properly spaced from the heat-sensitive parts during installation. Special attention should be paid to fuel pipes, wires and brake hoses.

In order to prevent the exhaust pipe from being damaged by vibration, it is necessary to fix it safely.

When laying exhaust pipes, be careful not to inhale the exhaust gas as combustion-supporting air

The pipe orifice of the exhaust pipe shall not be blocked by dirt and snow. The outlet of the exhaust pipe shall not be oriented in the direction of driving.

When the waste heat of the exhaust pipe is used to preheat the engine, the pipe port of the exhaust pipe is at least 5 cm away from the engine.

Protective instructions:

Every time it burns, it produces high temperatures and toxic waste.

Therefore, be sure to install the exhaust device according to the installation instructions.

No operation shall be carried out in the area in which the exhaust guide device is located during the heating operation.

When it is necessary to operate near the exhaust device, the heater should first be turned off until all components are completely cooled and protective gloves should be worn if necessary.

(10.) Installation of heating air ducts for heaters Heating air conduit

The installation assembly contains a flexible bellows with a diameter of 75 mm.

safety instruction

When laying and fixing heated air guide hoses and hot air exits, care should be taken not to contact or blow people, animals or temperature-sensitive materials directly with hot air because of their high thermal radiation, so as not to cause unnecessary injury and damage.

During the whole operation process from the beginning of heating operation to shutdown, there is high temperature on the hot air duct. Therefore, the operation in the area of hot air duct should be avoided during the whole heating operation. If you need

to work in this area, turn off the heater, wait for all components to cool completely, and wear protective gloves if necessary.

matters need attention

When installing heating air suction, it should be noted that under normal operation conditions, the exhaust gas from vehicle engine and heater must not be inhaled, and the heated air should not be accompanied by dust, salt fog and so on.

When circulating air is used for heating, it should be noted that the derived hot air can not be inhaled directly when the circulating air suction is placed.

If the fault occurs due to overheating, the local hot air temperature may be as high as 150 °C and the surface temperature as high as 90°C before the fault stops. Therefore, only the original high temperature resistant hot air hose in our installation assembly is allowed to guide the hot air

At the time of functional inspection, after about 10 minutes of operation, the average temperature of hot air discharge measured at a distance of about 30 cm from the outlet should not exceed 110 °C (the air inhalation temperature is about 20°C).

Heaters and their air ducts and other components, do not ravage, cover and pressure, so as not to cause injury, flammable burning or heater damage.

(11) Installation and precautions of dosing oil pump.

Installation angle of dose oil pump

When installing the dose oil pump, we should always pay attention to the upward tilt of the nozzle end, the installation angle should be greater than 15 degrees, and the installation angle between 15 and 35 degrees should be preferred.

After inserting the heater nozzle head, the oil pump nozzle head, the oil collector and the T type three-way nozzle head into the rubber connection hose, the tubing inserted at the other end should form a seamless docking with the tubing inserted at the other end to avoid the formation of bubbles in the oil path, resulting in noise and affecting the combustion effect.

Matters needing attention in Oil extraction and installation of T-type three-way parts

The three links must be connected between the original fuel tank and the original oil pump, and the connection between the original fuel pump and the engine must be prohibited, so as not to inject the fuel into the heater under high pressure of the original oil pump, which will cause great danger. If the original oil pump is installed in the tank, the T-shaped three-way oil should not be used to fetch the oil, so the oil feeder should be used to fetch the oil directly in the tank.

(12) Installation of oil feeder and matters needing attention

The vertical height of the oil pump installed below the tank, a = up to 3 m,

The vertical height of the oil pump installed above the tank, b = up to 1 m.

1. Vertical height from pump to heater (pump should be installed below heater) c = up to 1.5 m

Safety instructions for laying tubing

In order to prevent the tubing from being damaged or making noise due to vibration, it is necessary to fix it safely

When laying tubing, attention must be paid to avoid tension, friction or vibration caused by the torsion of the vehicle and the movement of the engine.

The oil pipe shall not be laid in high temperature environment and shall be far

from the heat source. Do not lay or fix the tubing in close range along the exhaust pipe of the heater or the engine. Always pay attention to the adequate insulation distance when crossing the pipe, and the high-temperature-resistant and flame-retardant protective hose shall be sleeved if necessary.

All oil supply equipment shall be installed. After the heater is started for a period of time, each part of the connecting piece shall be checked to see if there is any oil leakage.

to supply fuel to the heater, and direct power supply to the heater pump is prohibited!

Matters needing attention in Oil Road maintenance and Inspection

If you want to start using heaters every winter, check that the connections of the oil roads are loose. Connect hose, tubing, etc., whether there is aging phenomenon. After the heater is in operation for a period of time, check whether there is oil leakage in each connection part of the oil circuit. If there is an exception, it should be dealt with quickly.

When the heater is used for the first time every year, there may be no oil storage in the tubing for a long time, which leads to the normal operation of the heater in the first few times, which is a normal phenomenon. It needs to be started a few more times, and the oil pump can work normally after absorbing the fuel.

Installation of heater wiring harness and matters needing attention

Wiring of heater safety instruction

The electrical connection of the heater should be realized according to the cable compatibility criterion.

If the operation is improper, the electromagnetic compatibility shall be affected, and the following instructions shall be observed.

For waterproof plugs, blind plugs are used to seal the unoccupied plug cavity so that dirt and water are not allowed in.

The electrical plug connection and grounding must be realized without corrosion and firmly.

circuit diagram matters
need attention

The following items are noted on the original operation of the electric wiring for the heater and on the original operation.

When placing wires, switches, and controllers in a car, stay away from heating parts to avoid heating, moisture, and other functions.

When fixing a wire harness, do not fasten the harness to the running or vibrating parts so as not to break the wire harness or cause the joint to fall off

The positive and negative poles of the wire harness shall not be lengthened privately.

It is forbidden to use the heater in the vicinity of the flammable and explosive products (such as the flammable gas dust environment of the flammable material warehouse in the gas station of the liquefied gas station of the gas station, etc.).

V. maintenance and maintenance:

After the heater is used in winter, it should be removed from the car for cleaning and maintenance. Usually, there is no need for overhaul in a heating season, such as

finding that the thermal efficiency is obviously decreased, not easy to ignite or smoke

for a long time and other faults, we should stop in time to find out the cause, and wait for troubleshooting before it can be used. Oil tank tubing and oil filter should be kept clean and smooth and cleaned regularly according to the actual situation. During the non-use season, start and run the heater for 10 minutes each month to ensure that the heater is in normal condition

Six operation automatic control and function display A

knob on and off to control the use of:

Start heating: turn the knob switch clockwise, the status indicator and mode

indicator are lit, the heater carries on the self-test to each function, if there is no fault, start heating according to adjusting the heater power.

Mode switching: click the mode conversion button to switch running mode. Red light indicates warm air mode, green light is automatic air conditioning mode. In warm air mode, the heater is heated according to the knob to adjust the power. In automatic air conditioning mode, the heater intelligently adjusts the output power of the heater according to the set temperature and cockpit temperature, so that the cockpit temperature is constant.

Power regulation: the heater enters a stable combustion state after starting for 3

minutes, when the heating power or temperature can be adjusted by knob. Clockwise increases and counterclockwise adjusts to decrease.

mode indicator is off, when the heater stops and dissipates heat. When the heat dissipation is finished, the status indicator is off and the whole machine is off.

What do you think?

(1)Fault indication: if the heater fails, the state indicator will flicker the fault code. The fault code reading method is as follows: counting from fast flicker (about 20Hz), one number per slow flash (about 1Hz) until the end of the next fast flicker, the calculated value is the corresponding fault code, and the meaning of the fault code is shown in the fault code table.

B Instructions for the use of digital screen switch control:

(1)Start heating: when the heater is off, hold down the switch key for 1 second, the screen is lit up, display the current mode and set power (the digital display screen will save the last setting mode and set power), the heater will self-check the parameters, if there is no fault, start heating directly, and the display screen will display the heating status dynamically.

Mode switching:press the mode key to switch the operation mode to automatic air conditioning mode or heating mode.

Power regulation:press the add key to increase the output power or increase the set temperature, and press the decrement key to reduce the output power or the set temperature.

End heating: when the heater is in operation, press and hold the on/ off key for more than 1 second, and then stop the heating. At this time, the heater will stop and heat. When the heat dissipation is over, the digital display screen will be off automatically, and the whole machine is in the shutdown state.

Abnormal warning: when the heater is abnormal, the corresponding abnormal state indication icon is lit, the meaning of each exception icon is shown in the abnormal icon meaning table. 30 minutes later automatically shut down.

Warning: in general, the heater in the start-up and stop phase, will perform safety procedures and can not be forced to stop, so do not frequently perform on and off operations, so as not to affect the service life of the heater!Warning: in general, the heater in the start-up and stop phase, will perform safety procedures and can not be forced to stop, so do not frequently perform on and off operations, so as not to affect the service life of the heater!

Analysis and troubleshooting of seven faults:

Fault flicker code table for status indicator of warm parking heater

The number of times that the indicator light short pulse flashes quickly into a

cyclic long pulse slow flicker to a fault code is 1 second apart.

Fault prompt		Causes and treatment methods
Green indicator light Slow flash 1	Ignition failure	The fuel tank is short of oil and the tubing is open or frozen. Oil pump seal damage
Green Indicator flashes slowly 2 times.	Flameout	The fuel tank is short of oil and the tubing is open or frozen. Oil pump seal damage

Green indicator light Slow flash 3	Voltage anomal	Battery voltage is too high or too low
Green indicator light	Air outlet sensor	Check that the NTC sensor connector is loose
Green indicator light Slow flash 5	Intake air sensor	Replacement of circuit board by open circuit of inlet air sensor
time		fee
Green indicator light Slow flash 6	Oil pump	Check the wiring harness of the oil pump for an open circuit or if the plug-in falls off.

Green indicator light Slow flash 7	Fan	Check that the fan is jammed or the fan connector is misconnected
Green indicator light	ignition plug	Loose connector or invalid replacement of ignition plug
Green indicator light	Ultra-high temperature protection	Check to see if the air inlet and outlet are blocked, resulting in poor air flow and removal of the shield.

Green indicator light Slow flash of 10	Ultra-high temperature contact sensor	Check if the ultra-high temperature sensor connector is loose or open, short circuit
---	--	---

If the above methods cannot be eliminated or other faults are encountered, professional personnel or installation and maintenance station authorized by our company shall be responsible for maintenance.

The heater cannot be restarted when the heater is not completely shut down under the condition of failure.

Note: the heaters produced by our company shall not be exchanged with the same kind of products from other manufacturers, because of the different original models, the heaters will be damaged; if the heaters are damaged due to the swap of workpieces, our company will not be guaranteed!

Regulations on warranty of after-sales service:

1. This product after-sales service certificate, please take good care of the shopping voucher together.
2. Under normal circumstances, the machine will be guaranteed free of charge for 6 months.

If the product is faulty or damaged caused by abnormal use, it is not covered

by warranty. Manual and material fees are charged as appropriate for maintenance.

4 without the permission of our company, self-repair or non-maintenance of our maintenance site damage is also not covered by warranty.

Under normal circumstances, the customer does not operate illegally when using this product, and uses the product in accordance with the requirements of the operation guidelines and technical parameters.

The product model should be consistent with the repaired product model on the six warranty card, and must not be modified.

In the event of failure, please contact our dealers or after-sales service outlets immediately, or mail our after-sales service department.

The following cases are not covered by warranty. Damage caused by abnormal use or unexpected factors.

Natural disasters caused by man-made damage or improper access to power and commercial power supply, the company has to charge material cost fees for maintenance.

Failed to show warranty card or warranty card content does not match the product Disassemble or exceed the shelf life of the product on its own,

Use other factory accessories to our products, resulting in machine damage.
after-sales service warranty card (customer federation) date:

user name		Tel	
Heater model		installation site	

license plate		installation time	
motorcycle type		Installer	
maintenance time		Maintenance Items	