



**Count on it.**

**Parts Catalog**

**60V 21in Super Recycler®  
Lawn Mower**

Model No. 21566T—Serial No. 400000000 and Up



# Ordering Replacement Parts

To order replacement parts, please supply the part number, the quantity, and the description of each part desired.

## Understanding Reference Numbers

Each identified part in an illustration has a reference number. The reference number for a part also appears in the parts list, along with other information about the part.

This catalog uses two special reference number formats, one to indicate parts in a service assembly and another to indicate the quantity of a given part in an illustration.

## Service Assembly Reference Numbers

Parts in service assemblies have reference numbers in the form a:b. The a represents the reference number of the entire service assembly and the b represents a sequential number unique to each part within the service assembly.

For example, a wheel assembly might be identified by reference number 6, the tire by 6:1, the valve by 6:2, and the wheel by 6:3. When you order the assembly identified by reference number 6, you receive all parts identified by reference numbers 6:1, 6:2, and 6:3. However, you may also order any part individually. Reference numbers of this type appear in illustration and in parts lists.

## Reference Numbers Indicating Quantity

In an illustration, if a reference number indicates more than one part, the reference number has the form nX y. The n represents the quantity of the part, the X is the multiplication symbol, and the y represents the reference number.

For example, in an illustration, the reference number 2X 37 means that two of the parts identified by reference number 37 are indicated.

# Contents

Deck Assembly .....	4
Bag Assembly .....	6
Deck Decal Assembly .....	8
Motor Module and Blade Assembly .....	10
Motor Module No. 140-4203 Lower Shroud Assembly .....	12
Motor Module No. 140-4203 Upper Shroud Assembly .....	14
Front Wheel and Height-of-Cut Assembly .....	16
Rear Wheel and Height-of-Cut Assembly .....	18
Handle Assembly .....	20
Starter Switch Assembly .....	22
Attachments and Accessories .....	24

# Deck Assembly

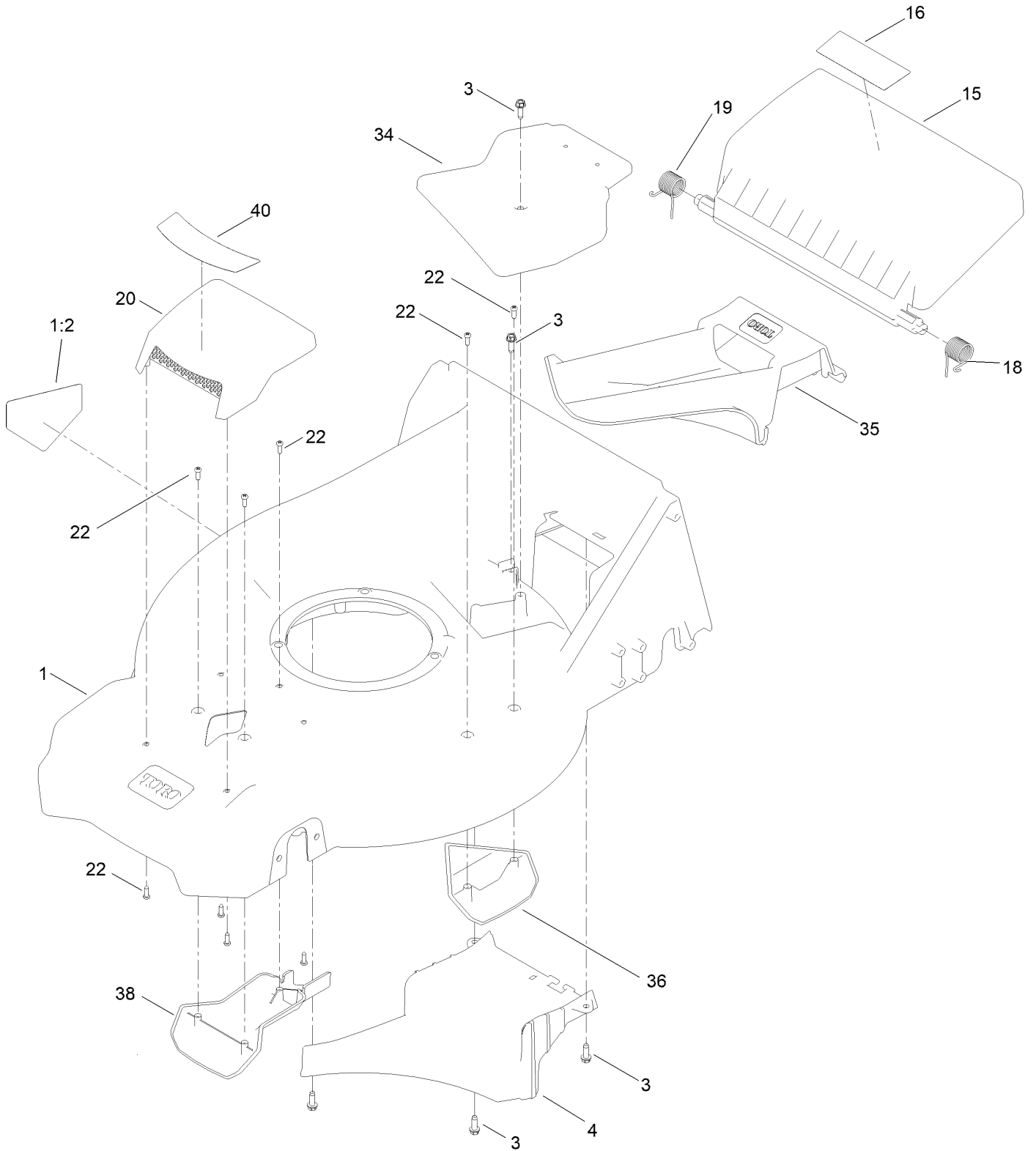

## Deck Assembly (continued)

<i>Ref.</i>	<i>Part Number</i>	<i>Qty.</i>	<i>Description</i>	<i>Ref.</i>	<i>Part Number</i>	<i>Qty.</i>	<i>Description</i>
1	145-5835	1	Housing ASM	20	144-6531	1	ASM-Cover, Top Intake
1:2	94-8072	1	Decal-Danger ●	22	139-1703	9	Screw-Plastic, PPH
3	49-2040	5	Screw-HWHTF	34	144-0234	1	Cover-Belt, Top
4	144-0233	1	Ramp-Discharge	35	144-0236	1	Plug-Mulch
15	139-5477	1	Door-Rear	36	144-0237	1	Kicker-Housing
16	145-1454	1	Decal-Warning	38	144-6464	1	Cover-Intake, Bottom
18	139-5478	1	Spring-Torsion, LH	40	145-5600	1	Decal-Cover, Intake
19	139-5479	1	Spring-Torsion, RH				

● Not illustrated

# Bag Assembly

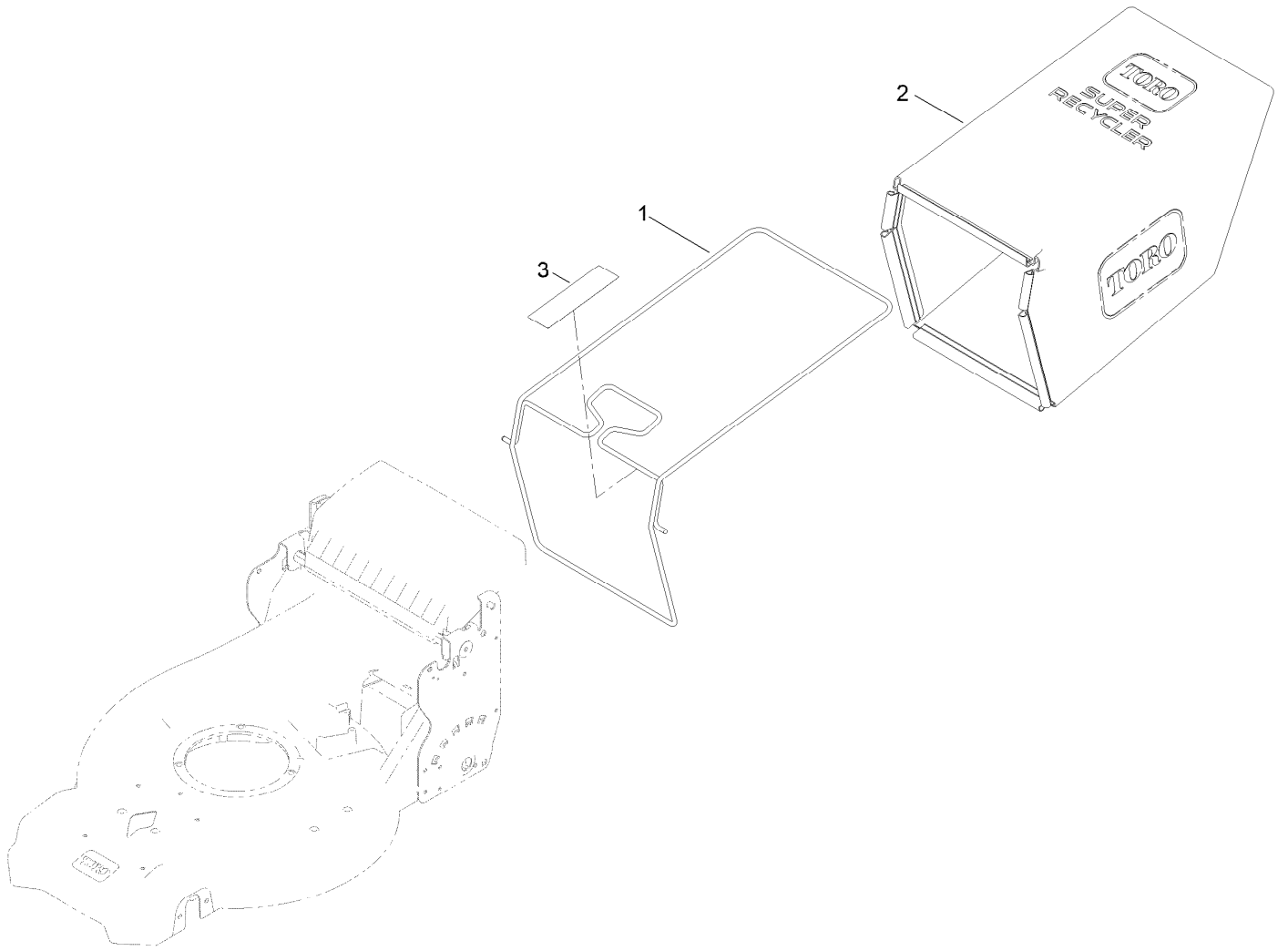

## Bag Assembly (continued)

<i>Ref.</i>	<i>Part Number</i>	<i>Qty.</i>	<i>Description</i>
1	139-5470-03	1	ASM-Frame, Bag
2	144-6509	1	ASM-Bag, Grass
3	139-8986	1	Decal-Warning (Bag)

# Deck Decal Assembly

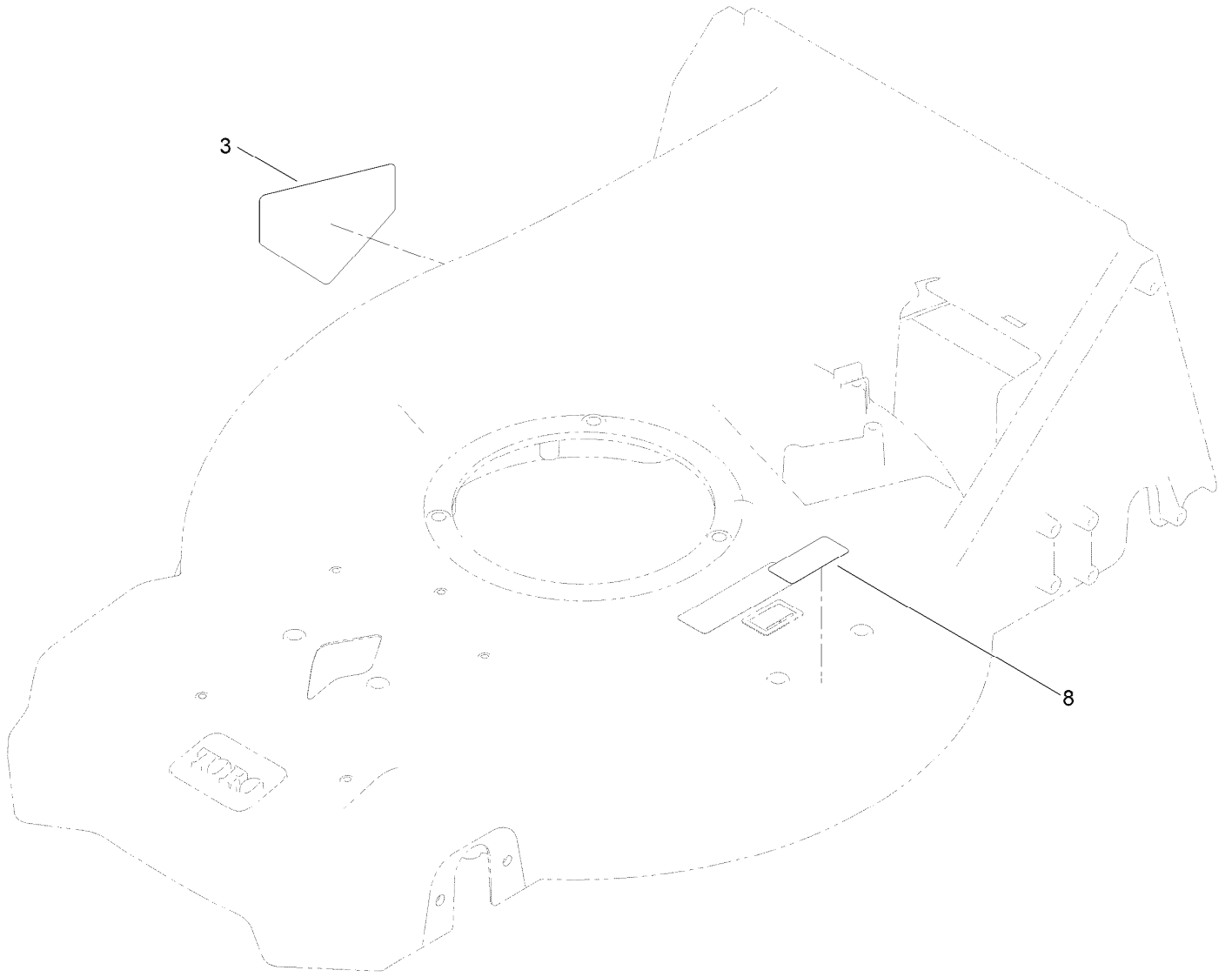

## Deck Decal Assembly (continued)

<i>Ref.</i>	<i>Part Number</i>	<i>Qty.</i>	<i>Description</i>
3	94-8072	1	Decal-Danger
8	121-5684	1	Decal-Location, Service Dealer

# Motor Module and Blade Assembly

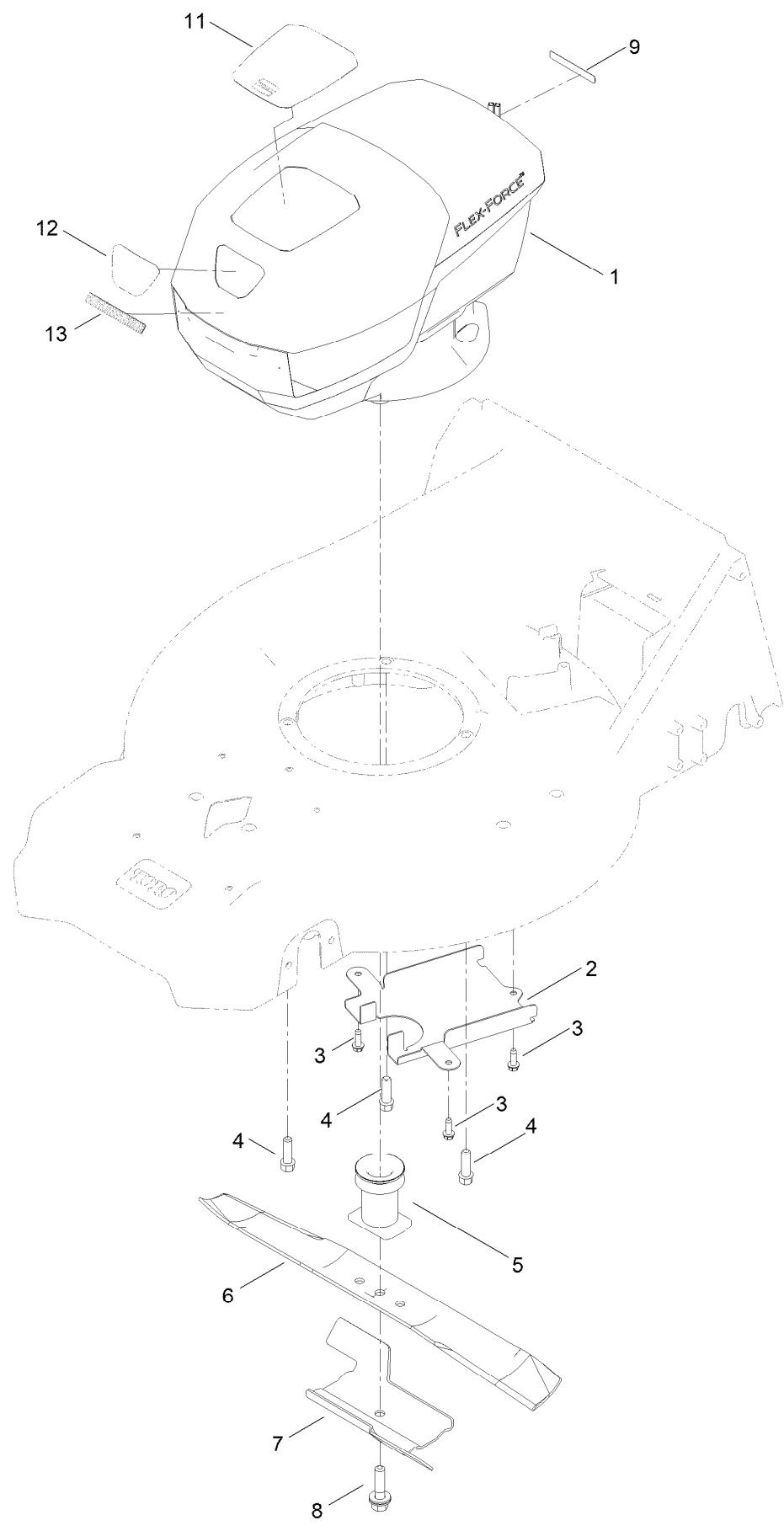

## Motor Module and Blade Assembly (continued)

<i>Ref.</i>	<i>Part Number</i>	<i>Qty.</i>	<i>Description</i>	<i>Ref.</i>	<i>Part Number</i>	<i>Qty.</i>	<i>Description</i>
1	140-4203	1	Motor Module	6	144-3178-03	1	Blade-21In Recycling Eco
2	144-0238-05	1	Cover-Belt, Bottom	7	105-6848-01	1	Accelerator-Blade
3	49-2040	3	Screw-HWHTF	8	125-2466	1	Bolt-Blade
4	95-1727	3	Screw-Taptite	9	133-8061	1	Decal-Warning
5	139-1816	1	Driver-Blade	11	145-4013	1	Decal
6	133-8183-03	1	Blade-Recycling, 21In Bagging	12	145-4014	1	Decal
				13	145-4015	1	Decal

# Motor Module No. 140-4203 Lower Shroud Assembly

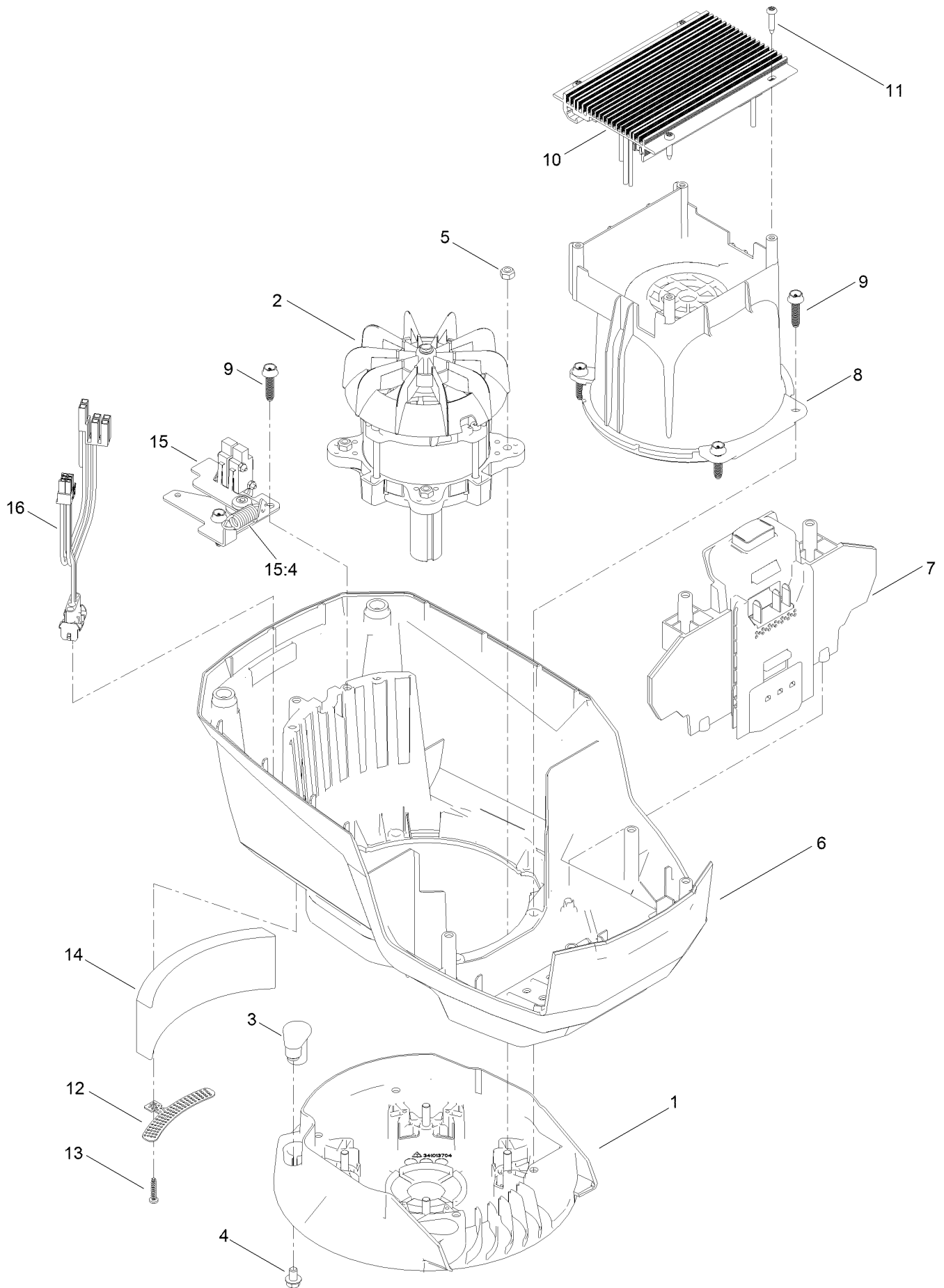

# Motor Module No. 140-4203 Lower Shroud Assembly (continued)

<i>Ref.</i>	<i>Part Number</i>	<i>Qty.</i>	<i>Description</i>	<i>Ref.</i>	<i>Part Number</i>	<i>Qty.</i>	<i>Description</i>
1	139-6628	1	Base-Mount, Motor	10	140-4117	1	Controller-Motor [2 Spd]
2	140-4119	1	Motor-2Kw	11	139-6642	4	Screw
3	131-9732	3	Insert-Mount, Motor	12	139-6635	1	Bracket-Foam
4	137-4795	3	Screw	13	138-3273	1	Screw-Plastic, PPH
5	115-7373	4	Nut-Lock	14	139-6636	1	Foam
6	139-6631	1	Shroud-Lower	15	133-1918	1	Bail Switch ASM
7	139-6632	1	Battery Reciever ASM	15:4	104-6478	1	Spring-Extension
8	139-6633	1	Shroud-Motor	16	139-6637	1	Harness-Wire
9	130-6658	6	Screw-Flange, Plastic				

# Motor Module No. 140-4203 Upper Shroud Assembly

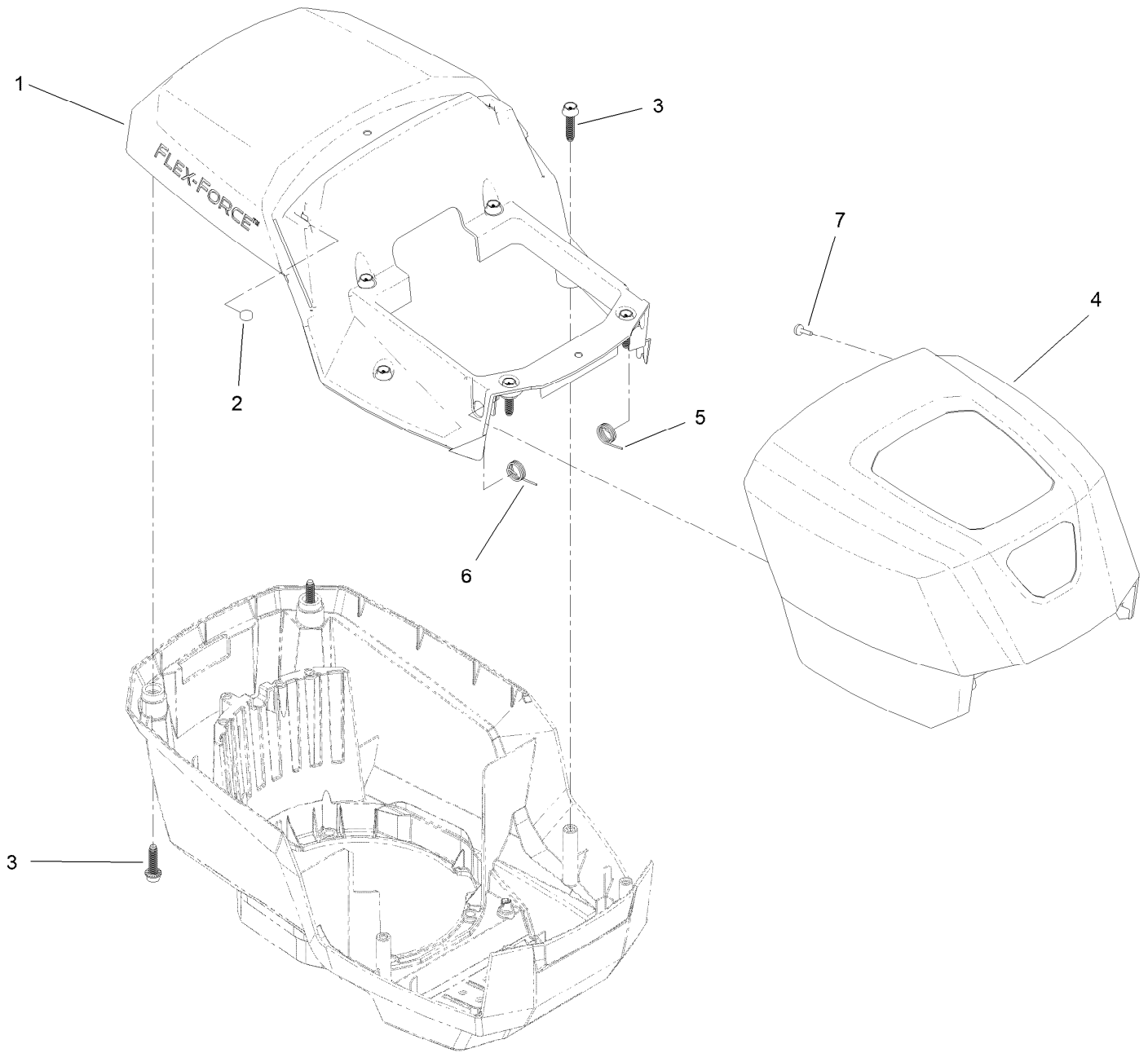

# Motor Module No. 140-4203 Upper Shroud Assembly (continued)

<i>Ref.</i>	<i>Part Number</i>	<i>Qty.</i>	<i>Description</i>	<i>Ref.</i>	<i>Part Number</i>	<i>Qty.</i>	<i>Description</i>
1	139-6638	1	Shroud-Upper	5	139-6640	1	Spring-LH
2	114-5896	2	Magnet	6	139-6641	1	Spring-RH
3	130-6658	8	Screw-Flange, Plastic	7	95-4234	2	Screw-PPH
4	139-6639	1	Hood				

# Front Wheel and Height-of-Cut Assembly

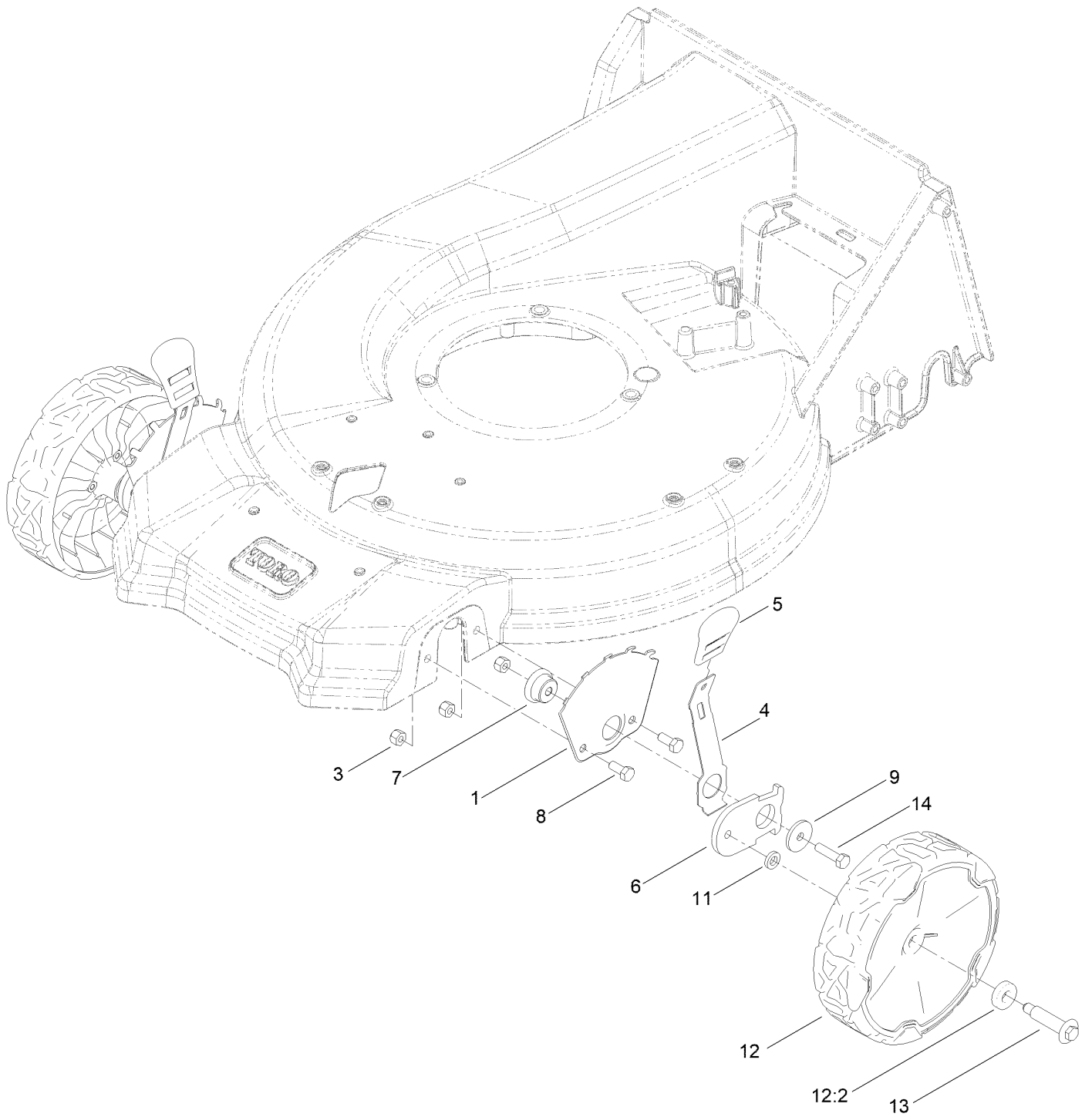

## Front Wheel and Height-of-Cut Assembly (continued)

<i>Ref.</i>	<i>Part Number</i>	<i>Qty.</i>	<i>Description</i>	<i>Ref.</i>	<i>Part Number</i>	<i>Qty.</i>	<i>Description</i>
1	115-1956-05	2	Plate-HOC,Front Fsvq	9	105-3048	2	Washer-Flat
3	3296-29	6	Nut-Lock, NI	11	139-5449	2	Washer-Wheel Bolt
4	105-1809	2	Arm-Spring	12	144-6469	2	ASM-Wheel, 8" (Bearings)
5	110-0549	2	Knob-HOC	12:2	52-2450	2	Bearing-Wheel
6	137-9128	2	Arm-Pivot, Front	13	614650	2	Bolt-Shoulder
7	105-1818	2	Bushing-Mount, HOC	14	322-6	2	Screw-HH
8	322-3	4	Screw-HH				

# Rear Wheel and Height-of-Cut Assembly

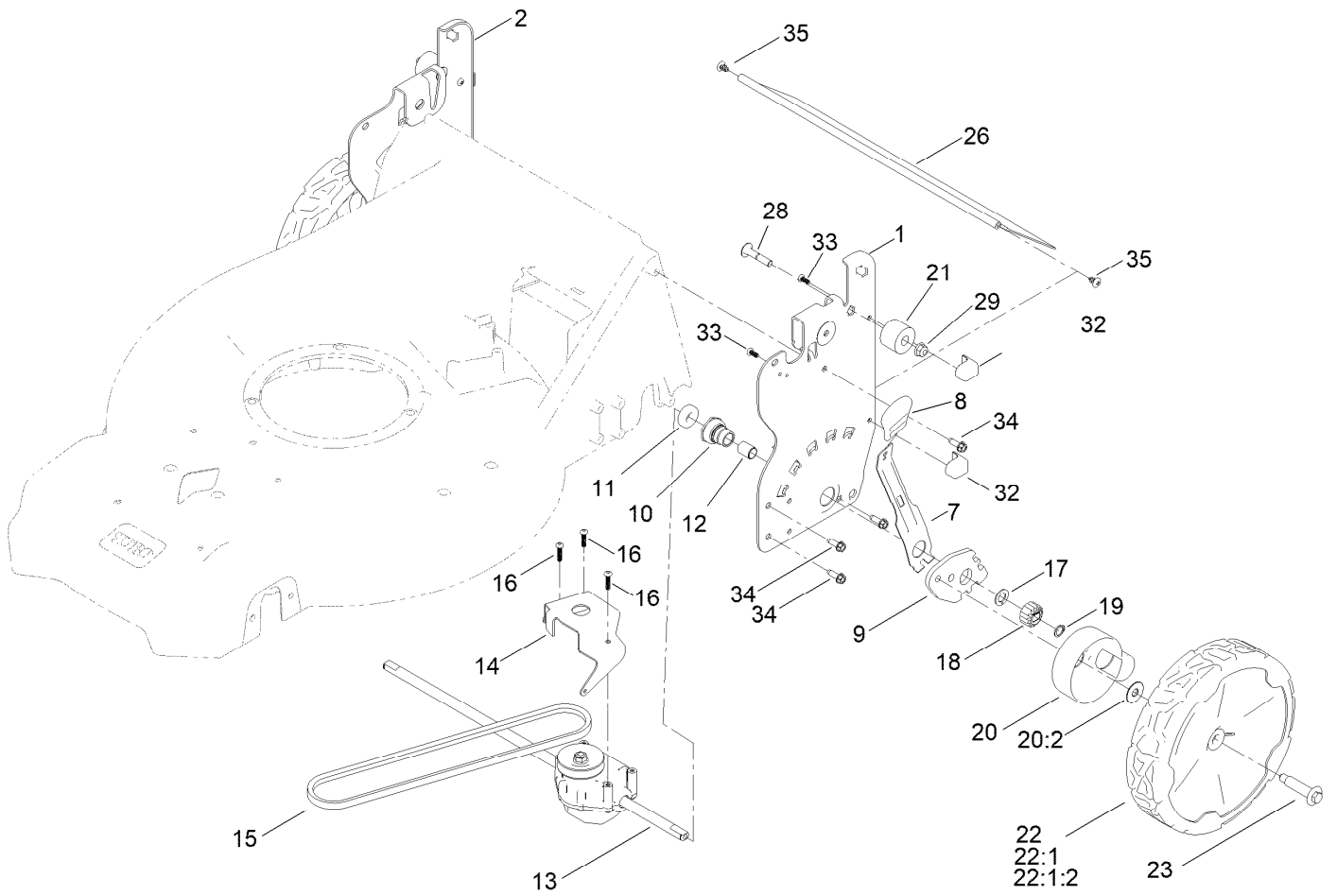

## Rear Wheel and Height-of-Cut Assembly (continued)

<i>Ref.</i>	<i>Part Number</i>	<i>Qty.</i>	<i>Description</i>	<i>Ref.</i>	<i>Part Number</i>	<i>Qty.</i>	<i>Description</i>
1	144-6476-05	1	Plate-HOC, LH	20	144-0240	2	ASM-Cover, Gear
2	144-6515-05	1	Plate-HOC, RH (ISO)	20:2	614426	1	Washer-Stepped
7	132-4486	2	Arm-Spring	21	144-0218	2	Bumper-Isolator
8	110-0549	2	Knob-HOC	22	144-6474	2	ASM-9.65" Wheel, Geared
9	139-5451	2	Arm-Pivot, Rear	22:1		1	ASM-Wheel, 9.65" (Bearings) ● ■
10	108-9779	2	Retainer-Bushing, HOC	22:1:2	52-2450	2	Bearing-Wheel
11	52-2450	2	Bearing-Wheel	23	139-1789	2	Wheel Bolt
12	108-9782	2	Bushing-Sleeve	26	139-6597	1	Shield-Trailing
13	144-0248	1	Transmission-Rwd, 5.25:1	28	322-7	2	Screw-HH
14	132-4481-03	1	Bracket-Trans, Rwd Hi	29	32128-20	2	Nut-HF
15	115-4669	1	Belt-V	32	140-2369	4	Pad-Smart Stow
16	108-7476	3	Screw-Plastite	33	107-7461	4	Screw-Plastite
17	110-7191	2	Washer-Thrust	34	49-2040	8	Screw-HWHTF
18	131-5399	2	Gear-Pinion, 15T	35	117-1092	2	Screw-PTH
19	32151-61	2	Ring-Retaining				

● Not illustrated

■ Not serviced separately

# Handle Assembly

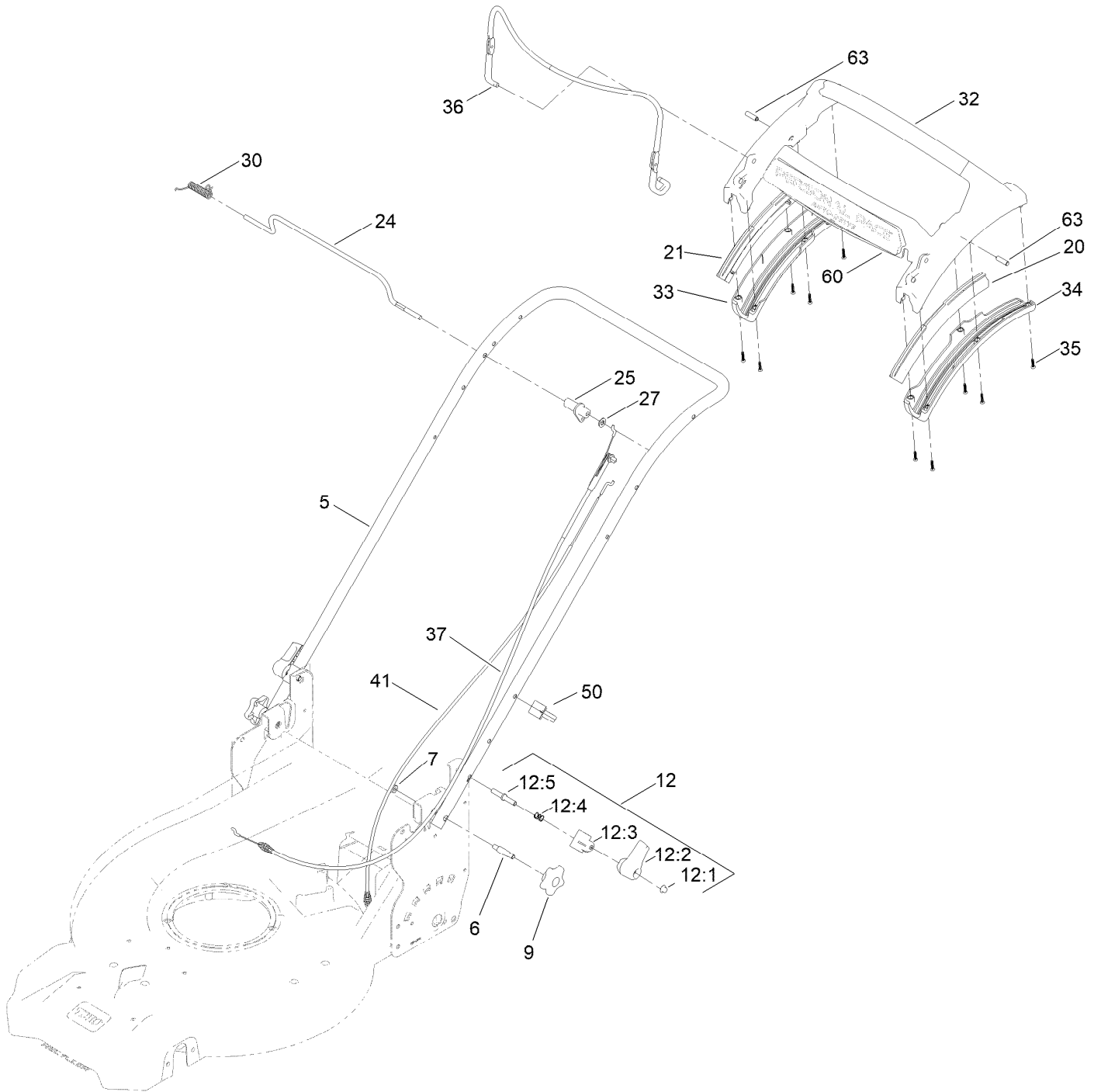

## Handle Assembly (continued)

<i>Ref.</i>	<i>Part Number</i>	<i>Qty.</i>	<i>Description</i>	<i>Ref.</i>	<i>Part Number</i>	<i>Qty.</i>	<i>Description</i>
5	144-6516-05	1	Handle-Curved	27	3256-23	1	Washer-Plain
6	139-6588	2	Bolt-Shoulder, Handle	30	140-4194	1	Spring-Torsion
7	3296-29	2	Nut-Lock, NI	32	139-6569	1	Handle-Personal Pace, Curved
9	117-5976	2	Knob-Handle	33	139-6567	1	Bottom-Handle, RH
12	138-3249	2	Quick Release ASM	34	139-6568	1	Bottom-Handle, LH
12:1	140-4157	1	Nut-Push	35	94-4496	10	Screw-PPH
12:2	138-3248	1	Lever-Release	36	145-5879-03	1	Bail-Brake
12:3	138-3253	1	Anchor-Spring	37	139-6594	1	Cable-Brake, Pp B&s
12:4	115-2858	1	Spring-Compression	41	139-6595	1	Cable-Traction, Rwd (Pp)
12:5	140-4158	1	Rod-Release	50	114-7988	1	Guide-Cable
20	140-2367	1	Guide-Curved, LH (Rwd)	60	145-5601	1	Decal-Handle, Pp
21	140-2366	1	Guide-Curved, RH (Rwd)	63	139-6577	2	Pin-Handle, Pp
24	139-5464	1	Rod-Control, Traction				
25	139-6554	1	Lever-Traction, Rwd				

# Starter Switch Assembly

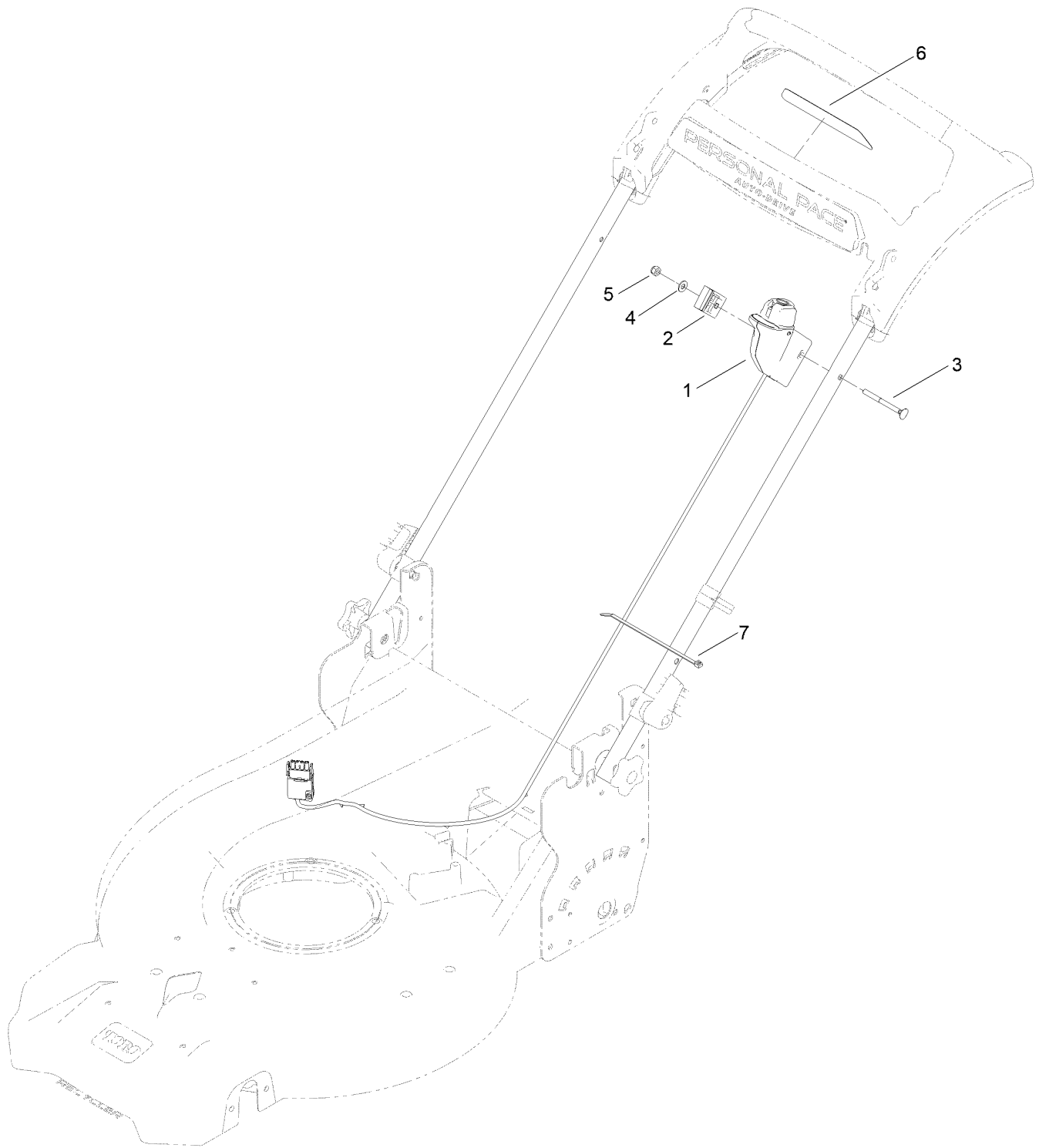

## Starter Switch Assembly (continued)

<i>Ref.</i>	<i>Part Number</i>	<i>Qty.</i>	<i>Description</i>	<i>Ref.</i>	<i>Part Number</i>	<i>Qty.</i>	<i>Description</i>
1	144-3179	1	Starter Switch ASM	5	3296-73	1	Nut-Lock, NI
2	140-4128	1	Clamp-Cable	6	140-1324	1	Decal-Controls (60V, Start)
3	140-3985	1	Screw-Handle	7	614249	1	Tie-Cable
4	3256-1	1	Washer-Flat				

# Attachments and Accessories

## For 21566T 60V 21in Super Recycler Lawn Mower

<b>Product Name</b>	<b>Model/Part</b>
Bagging Blade .....	108-3759-03
Discharge Chute ASM .....	144-0242
Lawn Striping Kit with 22in Roller.....	20601
Power Clear 21in 60V Cordless (Bare Tool).....	39901T
Smart Stow Walk Power Mower Cover .....	490-2012
Bag-Walk Behind (Toro).....	490-7318
Lawnmower Cover.....	490-7462
60V Cordless Blower (Bare Tool).....	51820T
60V Cordless Trimmer (Bare Tool).....	51830T
60v 24in Max Hedge Trimmer (Bare Tool).....	51840T
16in 60V Max Chainsaw (Bare Tool).....	51850T
60V Battery Charger 2 AMP .....	88602
60V Rapid Battery Charger 5.4 AMP .....	88605
60V LI-ION, Battery 4.0 AH .....	88640
60V LI-ION Battery 5.0 AH.....	88650
60V LI-ION Battery 6.0 AH.....	88660
60V LI-ION Battery 7.5 AH.....	88675

**Notes:**

**Notes:**

**Notes:**



**Count on it.**