

# Owners Manual

Product Code: 1145T

**MADE FOR THE  
TRADE**

**TQ TRADEQUIP**  
the trusted brand in equipment

**TRUCK FLUID  
DRAIN PAN**

#### Specifications

- Capacity: 95 Litres
- Minimum Tray Clearance: 196mm
- Reservoir Dimensions: 910(L) x 725(W) x 165(H)mm
- Overall Dimensions: 1120(L) x 780(W) x 195(H)mm



#### About the Tradequip brand

The 'Tradequip' brand of workshop equipment, is designed for use in a demanding workshop environment by professional users. With proven and trusted "Made for the Trade" reliability, 'Tradequip' branded products offer the very best in performance for an affordable price. All backed by a 1 year trade guarantee across 1,000+ distributors Australia wide.

**TQ TRADEQUIP**  
the trusted brand in equipment

**TQ PRO**  
Trusted by serious craftsmen

**BORUM**  
INDUSTRIAL WORKSHOP EQUIPMENT

Made in China to TQB Brands Pty Ltd specifications.

Visit us at [www.tqbbrands.com.au](http://www.tqbbrands.com.au)

**WARNING**

**IMPORTANT: READ ALL INSTRUCTIONS BEFORE USE**



**WARNING**

The instructions and warnings contained in this manual should be read and understood before using or operating this equipment. Do not allow anyone to use or operate this equipment until they have read this manual and have developed a thorough understanding of how this equipment works. Failure to observe any of the instructions contained in the manual could result in severe personal injury to the user or bystanders, or cause damage to the equipment and property. Keep this manual in a convenient and safe place for future reference.

Whilst every effort has been made to ensure accuracy of information contained in this manual, the TQB Brands Pty Ltd policy of continuous improvement determines the right to make modifications without prior warning.

**CONTENT**

WARNING..... 2

CONTENT..... 2

STANDARD OPERATING PROCEDURE ..... 3

ASSEMBLY, OPERATION, PREVENTITIVE MAINTENANCE..... 4

PARTS LIST..... 6

WARRANTY..... 7

## STANDARD OPERATING PROCEDURE

**DO NOT** use this machine unless you have been trained and assessed to a competent level in its safe use and operation, and have been given permission to use this



Safety glasses must be worn when operating this equipment



Long loose hair must be contained when operating this equipment



Safety footwear must be worn when operating this equipment



Close fitting/protective clothing must be worn when operating this equipment

## PRE-OPERATIONAL SAFETY CHECKS

- Before using the 95 Litre Truck Oil Drainer Pan ensure it is in sound condition, and good working order.
- Replace or repair damaged parts. *Use recommended parts only. Non authorised parts may be dangerous and will invalidate the warranty.*
- Spillages of liquid material, which may be slippery, must be cleaned up immediately to avoid injury.
- Before using the Oil Drainer, the vehicle's engine must be off. Place the transmission in park (automatic transmission) or in gear (manual transmission) and apply the park brake.
- Operators should maintain correct balance and footing. Ensure the floor is not slippery and wear non slip shoes.
- Wear approved ear, eye, hand and respiratory protection when operating this product.
- DO NOT operate unit if any parts are missing or damaged as this may cause failure and/or personal injury.
- DO NOT allow untrained persons to operate the product.



**WARNING** - Oil in the vehicle's oil pan may be extremely hot and has the potential to burn; be careful to avoid contact with skin.

## INTENDED USE

This oil drainer is designed to drain waste oil from engines, gearboxes and differentials of most vehicles.

**ASSEMBLY, OPERATION, PREVENTITIVE MAINTENANCE****1. FEATURES**

The 95 Litre Truck Oil Drainer Pan is used for collecting used oil. It is ideal for draining oil from 4WD, trucks, heavy industrial equipment maintenance and repair.

The oil is collected into the 95 litre steel reservoir. A metal grate prevents oil spillage during the vehicle draining process and used oil transfer to and from the oil disposal reservoir. The drainer is fitted with two fixed rear wheels and two front swivel castors and grab handle for ease of under vehicle positioning. Used oil can be transferred by either gravity or suction evacuation.

**2. ASSEMBLY**

**Unpacking:** After removing the packing material, make sure the product is in perfect condition and that there are no visible damaged parts. The packaging materials (polyethylene bags, polystyrene etc) must be disposed of in an appropriate refuse collection container. These materials must not be left within the reach of children as they are potential sources of danger.

1. Attach the Handle (3) by fitting it inside the bracket on the side or between the two front castor brackets. Secure with Bolt (7), Washer (6) and Nut (5).
2. The front Braked Swivel Castors (14) fit on the brackets on each side of the front handle bracket.
3. Insert a Braked Swivel Castor (14) through the hole in the bracket from the bottom and attach with a Washer (9), Spring Nut (15) and a Nut (8). Repeat on opposite side.
4. Insert the rear Castor Wheels (10) at the rear of the Reservoir (4) through the hole in the bracket from the bottom and attach with a Washer (9), Spring Nut (15) and a Nut (8). Repeat on opposite side.
5. Before threading the Drain Valve (13) onto the front of the Reservoir (3), wrap teflon thread sealing tape (not included) clockwise around the drain outlet thread. Thread on the Drain Valve (13) ensuring the valve lever faces upward.
6. Insert the Pump Coupler (11) using the Nylon Washer (12) into the top corner of the reservoir.

**3. BEFORE USE**

Prior to each use conduct a visual inspection by checking for abnormal conditions, such as cracked joints and damaged, loose, or missing parts.

**4. OPERATION**

 **WARNING:** Before using the Truck Oil Drainer, the vehicle's engine must be off. Place the transmission in park (automatic transmission) or in gear (manual transmission) and apply the parking brake. Oil in the vehicle's oil pan may be extremely hot and has the potential to burn; be careful to avoid contact with skin.

1. Roll the Truck Oil Drainer under the vehicle directly under the drain sump plug of the vehicle. Ensure the lever on the Drain Valve (13) is perpendicular to the valve and in the closed position.
2. Open the sump plug and allow oil to flow into the Truck Oil Drainer.
3. When the oil has been completely drained from the vehicle, replace the vehicle's sump plug and roll the Oil Drainer out from under the vehicle.
4. The Oil Drainer offers two options to transfer the used oil into an approved oil disposal storage container.

**Option 1:**

**Gravity Flow:** Roll the Oil Drain directly over the approved storage tank and make sure the Drain Valve (13) sits directly over the container. Turn the lever parallel to the Drain Valve (13) to release the oil. For added safety and convenience attach a rubber hose (not included) using a hose clamp (not included) to the barbed fitting on the Drain Valve (13).

**Option 2: (Pump not included)**

**Manual or Electric Pump:** Attach a hose (not included) for a manual or electric oil transfer pump to the Pump Coupler (11). Ensure the hose fits snugly to prevent leakage. Begin hand cranking or turn on the electric pump to the lowest possible setting to transfer the used oil/fluid to an approved waste disposal storage container.

**Caution:** Oil residue will remain after the collected waste oil has been removed from the Oil Drainer. Immediately wipe Reservoir (4) clean with a rag to remove oil residue. Store the Oil Drainer away from all ignition sources and flammable materials.

## 5. STORAGE

This 95 Litre Truck Oil Drainer Pan should always be stored empty and clean in a dry location. Store the Oil Drainer away from all ignition sources and flammable materials. Wipe down Oil Drainer thoroughly with a rag to remove oil residue.

## 6. MAINTENANCE

Replace or repair damaged parts. Use recommended parts only. Non authorised parts may be dangerous and will invalidate the warranty.

1. After each use, remove the Filter Screen (1) and clean off any debris which accumulates.
2. Periodically check the tightness of all components, bolts, nuts, wheels, castors and the handle.
3. Occasionally open the Drain Valve (13) and run a pipe cleaner through the Drain Valve (13) to clear out any dirt or debris.

## 7. SERVICE & REPAIR

Any 95 Litre Truck Oil Drainer Pan found damaged in any way or found to be worn or operates abnormally should be removed from service until repaired by an authorised service agent. Owners and / or operators should be aware that repair of this product may require specialised equipment and knowledge. Only authorised parts, labels and decals shall be used on this equipment. Annual inspection of the 95 Litre Truck Oil Drain Pan is recommended and can be made by an authorised repair facility to ensure that your equipment is in optimum condition and that the equipment has the correct decals and safety labels specified by the manufacturer.

## PARTS LIST

Part	Description	Qty
1	Filter screen	1
2	Handle grip	1
3	Handle	1
4	Reservoir	1
5	Nut	1
6	Washer	1
7	Bolt	1
8	Nut	4
9	Washer	4

Part	Description	Qty
10	Castor Wheel (non-braked)	2
11	Coupler	1
12	O-Ring	1
13	Drain Valve	1
14	Castor (with brake)	2
15	Spring washer	4
16	Washer	1
17	Eye bolt	1

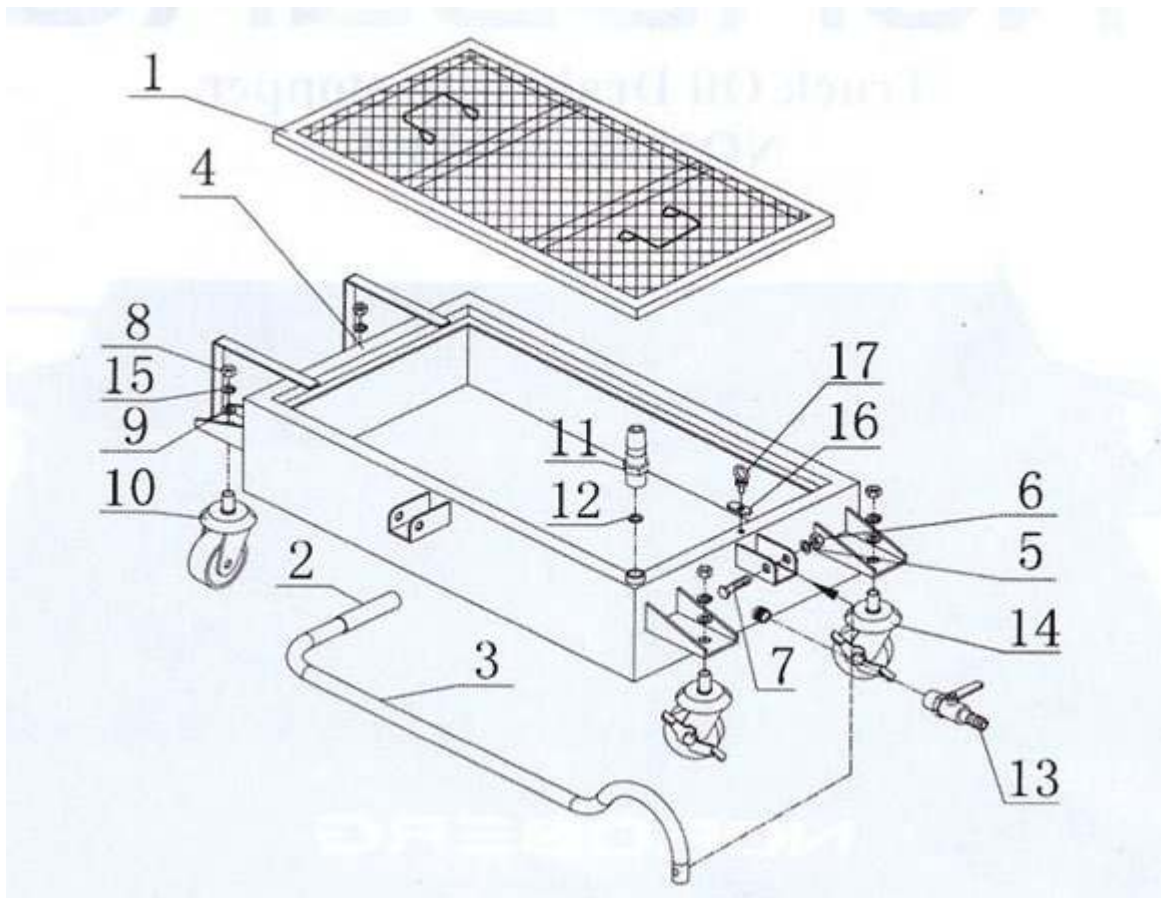

## WARRANTY

TradeQuip products have been carefully tested and inspected before shipment and are guaranteed to be free from defective materials and workmanship for a period of 12 months from the date of purchase except where tools are hired out when the guarantee period is ninety days from the date of purchase.

Should the machine develop any fault, please return the complete tool to your nearest authorised warranty repair agent or contact TQB Brands Pty Ltd Warranty team – [warranty@tqbbrands.com.au](mailto:warranty@tqbbrands.com.au).

If upon inspection it is found that the fault occurring is due to defective materials or workmanship, repairs will be carried out free of charge. This guarantee does not apply to normal wear and tear, nor does it cover any damage caused by misuse, careless or unsafe handling, alterations, accident, or repairs attempted or made by any personnel other than the authorised TQB Brands Pty Ltd repair agent.

This guarantee applies in lieu of any other guarantee expressed or implied and variations of its terms are not authorised.

Your TQB Brands Pty Ltd guarantee is not effective unless you can produce upon request a dated receipt or invoice to verify your proof of purchase within the 12 month period.

### Consumer Guarantee

Our goods come with a guarantee that cannot be excluded under the Australian Consumer Law. You are entitled to a replacement or refund for a major failure and compensation for any other reasonably foreseeable loss or damage. You are also entitled to have the goods repaired or replaced if the goods fail to be of acceptable quality and the failure does not amount to a major failure.



All images and illustrations shown are for reference purposes only. All information, specifications and illustrations in this manual are based on the latest information available at the time of publication and are subject to change without notice. The information in this manual is periodically revised to ensure the latest information is included. Download the latest version of this manual and other related technical documentation from [www.tqbbrands.com.au](http://www.tqbbrands.com.au)