

# Installer's Guide

## Integrated Variable or Multi Speed Control Drive Replacement

ALL phases of this installation must comply with NATIONAL, STATE AND LOCAL CODES

**IMPORTANT** — These instructions do not cover all variations in systems, nor do they provide for every possible contingency to be met in connection with the installation. Should further information be desired, or should particular problems arise which are not sufficiently covered for the purchaser's purposes, the matter should be referred to your installing dealer or local distributor.

**IMPORTANT** — Please ensure correct drive is used as replacement. This can be verified by the drive label color and unit tonnage.

2-3T Variable Speed: Replace with Green or Pink labeled drive

4-5T Variable Speed: Replace with Pink labeled drive ONLY

2-5T Multi Speed: Replace with Orange labeled drive ONLY

**IMPORTANT** — Do not replace the AOC only. This replacement drive comes with an AOC and MOC, and they must stay together as an assembly to ensure firmware compatibility between the two.

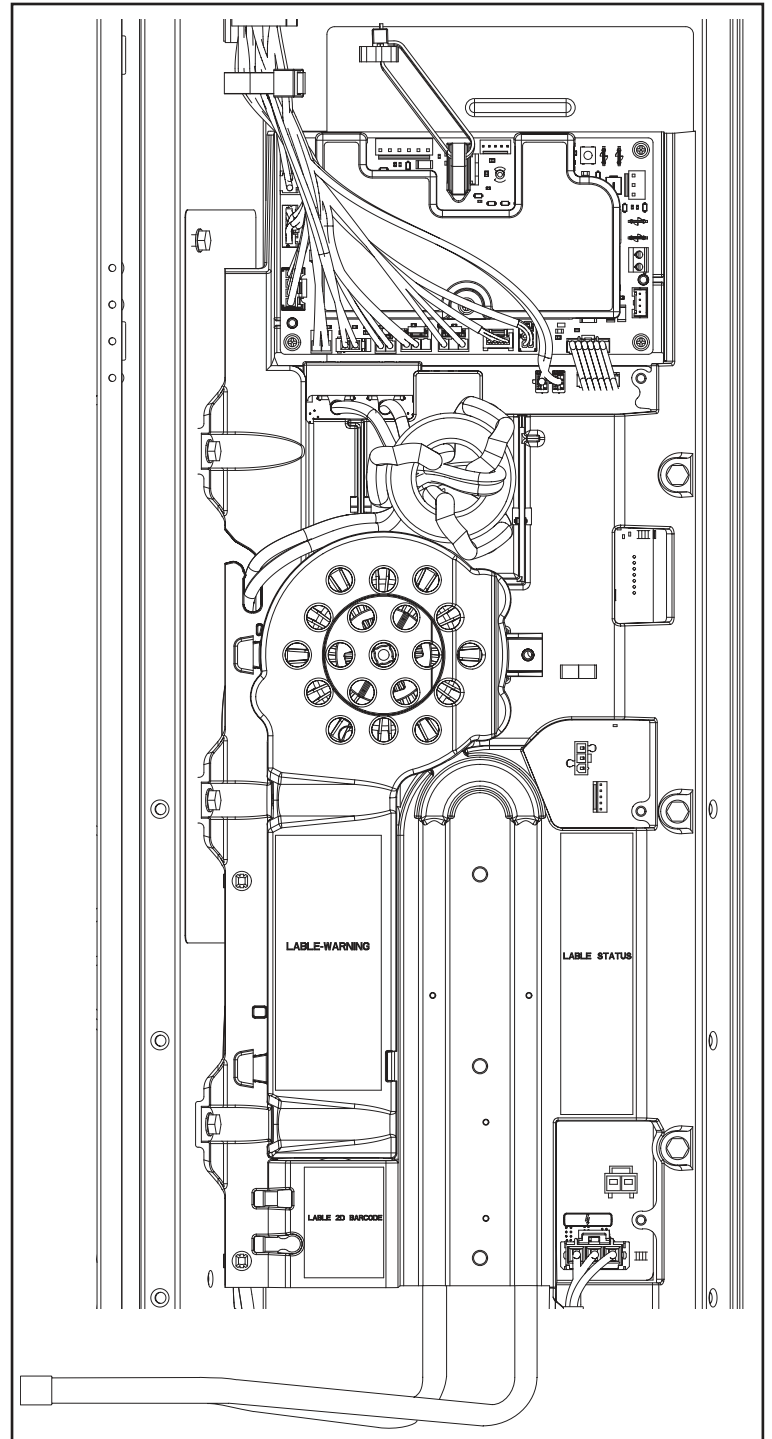

## Table of Contents

Section 1. Safety .....	2
Section 2. Tools and Parts Required .....	3
Section 3. Terminology .....	3
Section 4. Remove Drive.....	4
Section 5. Apply Thermal Grease.....	6
Section 6. Reinstall the Drive .....	7
Section 7. Perform Final Inspection.....	7
Section 8. Return Drive Board.....	7

## Section 1. Safety

### SAFETY WARNING

Only qualified personnel should install and service the equipment. The installation, starting up, and servicing of heating, ventilating, and air-conditioning equipment can be hazardous and requires specific knowledge and training. Improperly installed, adjusted or altered equipment by an unqualified person could result in death or serious injury. When working on the equipment, observe all precautions in the literature and on the tags, stickers, and labels that are attached to the equipment.

### WARNING

#### HAZARDOUS VOLTAGE!

Failure to follow this Warning could result in property damage, severe personal injury, or death. Disconnect all electric power, including remote disconnects before servicing. Follow proper lockout/tagout procedures to ensure the power cannot be inadvertently energized.

### WARNING

#### HIGH LEAKAGE CURRENT!

Failure to follow this warning could result in property damage, severe personal injury, or death. Earth connection essential before connecting supply.

### CAUTION

#### GROUNDING REQUIRED!

Failure to inspect or use proper service tools may result in equipment damage or personal injury. Reconnect all grounding devices. All parts of this product that are capable of conducting electrical current are grounded. If grounding wires, screws, straps, clips, nuts, or washers used to complete a path to ground are removed for service, they must be returned to their original position and properly fastened.

### CAUTION

#### HOT SURFACE!

May cause minor to severe burning. Failure to follow this Caution could result in property damage or personal injury. Do not touch compressor.

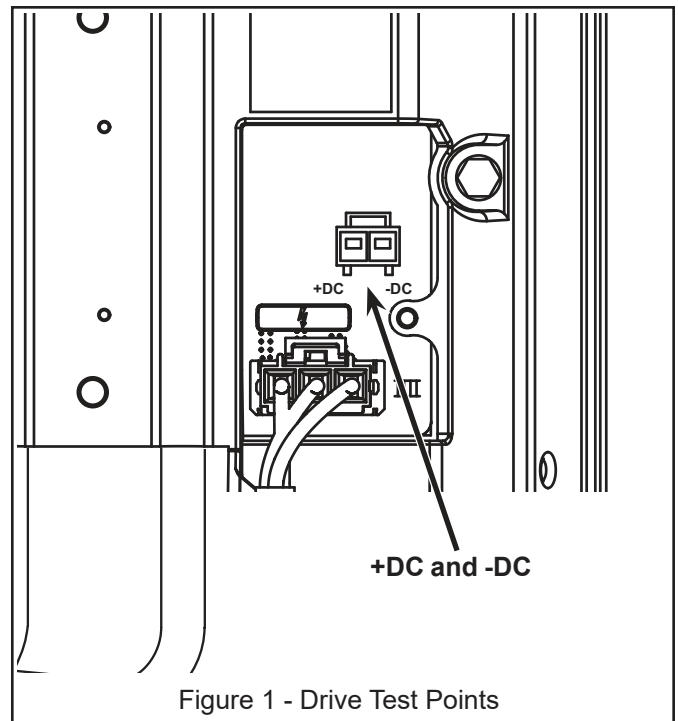
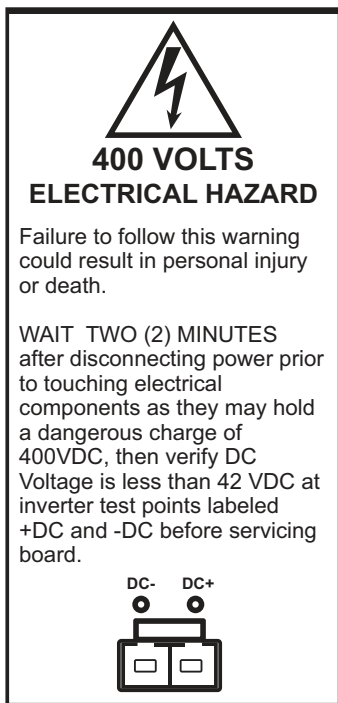

Figure 1 - Drive Test Points

## Section 2. Tools and Parts Required

### 2.1 - Tools Required

The following tools are required to perform the procedures described in this document:

- DC Volt Meter
- 5/16" Nut Driver
- 7/16" Socket Wrench
- Torque Wrench w/ 7/16" Socket

### 2.2 - Parts Required

All required parts are contained in the Replacement Kit that accompanies this document. They include:

- Thermal Grease
- Aluminum Nuts (3) - These Aluminum Nuts secure the Cold Plate to the Drive assembly. These are spares and should be used in the event of damage to the ones installed on the Unit.

Verify that you have the required tools and parts before proceeding.

## Section 3. Terminology

The following terms and abbreviations are used in this document.

Drive ..... same as MOC  
 Drive Assembly ..... same as AOC and MOC  
 EEV ..... Electronic Expansion Valve  
 HPCO ..... High Pressure Cut Off  
 IVSC ..... Integrated Variable Speed Control  
 PM ..... Personality Module  
 IMSC ..... Integrated Multi Speed Control

## Section 4. Remove Drive

### 4.1 - Power Down Unit and Remove Cover

1. Power down the Outdoor Unit and wait at least 2 minutes.
2. Remove the 4 screws securing the Control Box cover and place screws and cover aside (See "Figure 2 - Outdoor Unit").

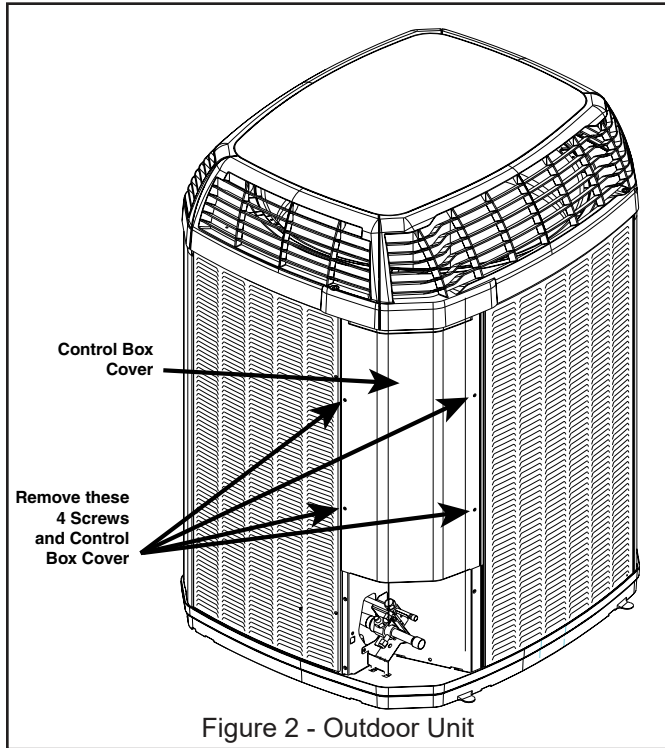

Figure 2 - Outdoor Unit

3. Test voltage across Inverter test points (see "Figure 1 - Drive Test Points on page 3.")

**WARNING - DO NOT PROCEED** until DC voltage measures less than 42 VDC.

### 4.2 - Remove Connections

1. Remove the ground wire (see "Figure 3 - Compressor Connections") located at the bottom of the Drive.
2. Disconnect the harness.

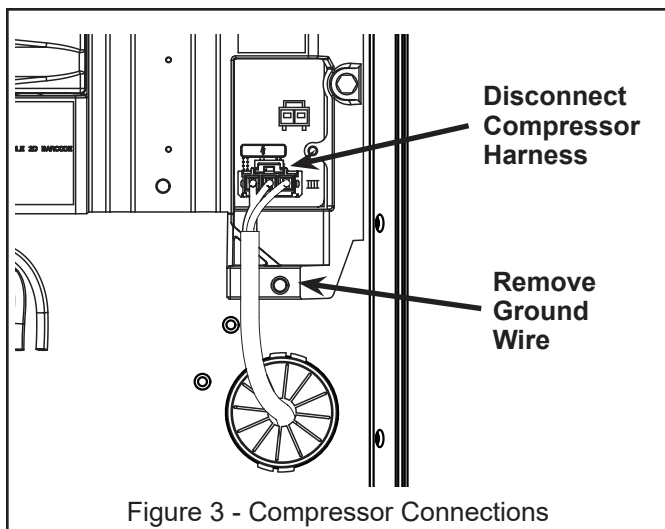

Figure 3 - Compressor Connections

The original drive in unit may have ferrite harnesses attached to HPCO leads, fan motor or compressor harness. Please re-use these as the replacement drive in this kit does not come with additional ferrites.

3. Unplug all AOC connectors located at the top of the drive and move the leads aside.

### Variable Speed Drives

You will unplug these connectors from the AOC (See "Figure 4 - IVSC Connections"):

- Latching Switchover Valve J17
- EEV J5
- CAN J20
- Ambient Temperature J21
- Discharge Temperature J22
- Coil Temperature J23
- Suction Temperature J24
- Liquid Temperature J25
- Suction Pressure J26
- Liquid Pressure J27
- Personality module J16

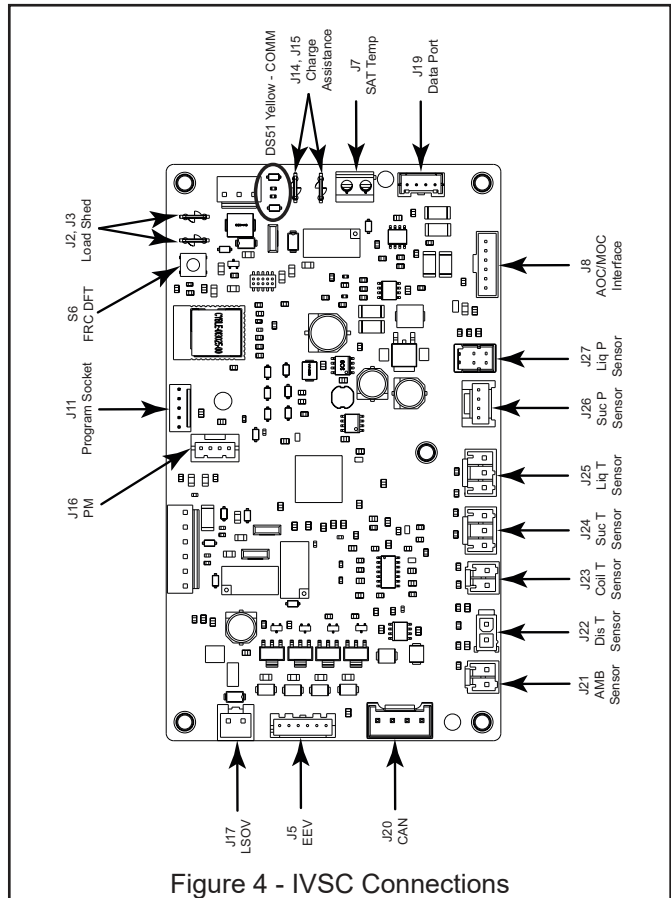

Figure 4 - IVSC Connections

### Multiple Speed Drives

You will unplug these connectors from the AOC (See "Figure 5 - IMSC Connections"):

- Latching Switchover Valve (LSOV) J17
- Electronic Expansion Valve (EEV) J5
- Ambient Temperature (AMB) J21
- Discharge Temperature (Dis\_T) J22
- Coil temperature (Coil\_T) J23
- 24 VAC Thermostat Control J4
- Personality Module J16

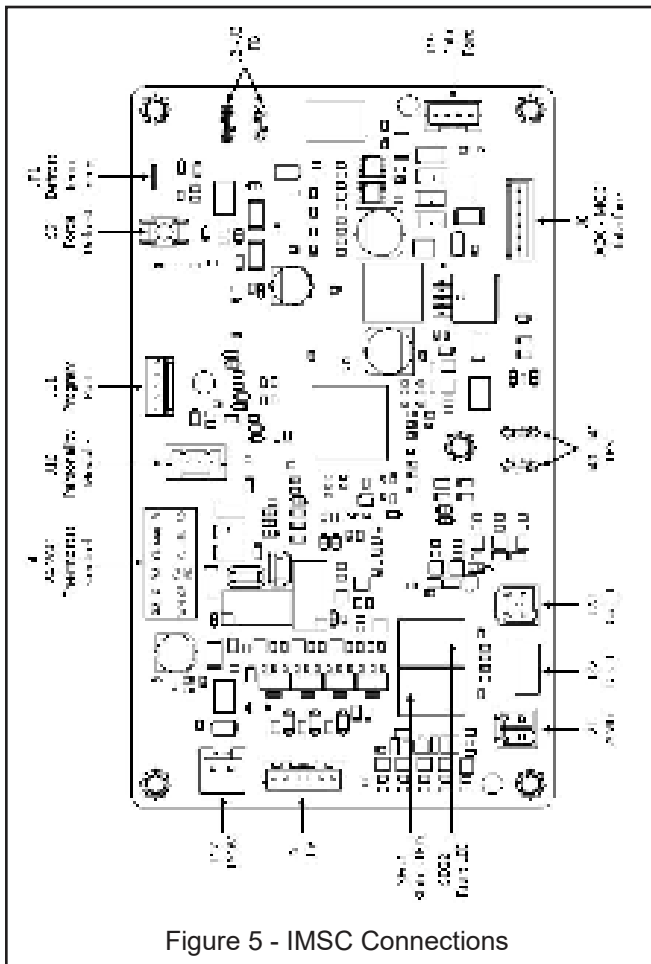

Figure 5 - IMSC Connections

Unplug the HPCO wires, fan harness and compressor harness from the MOC (See Figure 6 - MOC Drive Connections).

Disconnect high voltage field connections. Use care when removing the connectors. Some have latching tabs that must be depressed while removing. **DO NOT PULL ON WIRES.** Grasp by connector only when removing plug from board.

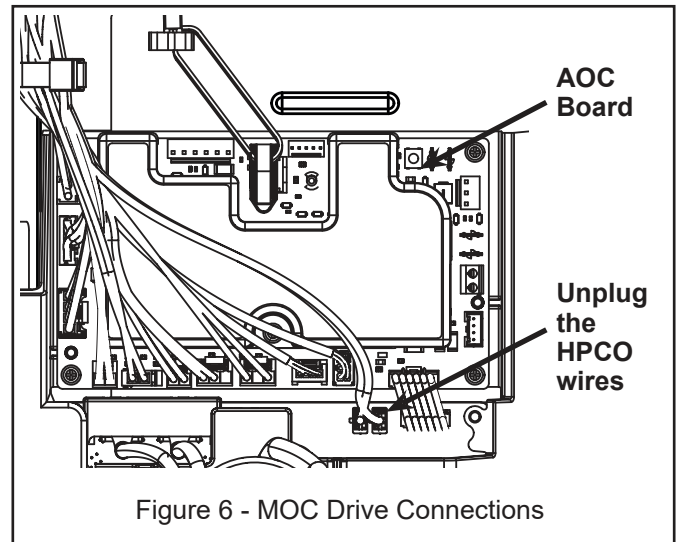

Figure 6 - MOC Drive Connections

#### 4.3 - Remove the Cold Plate

1. Remove the three Aluminum nuts securing the Cold Plate to the Drive Assembly (See "Figure 7 - Drive Cold Plate") and set aside. You will use a Torque Wrench when reattaching Cold Plate to Drive.
2. Remove the Cold Plate and set aside. Avoid direct contact with the Thermal Grease that is exposed when the Plate is removed.
3. Separate the Liquid Line from the Drive Assembly one to two inches. Be careful not to bend or strain the copper tubing.

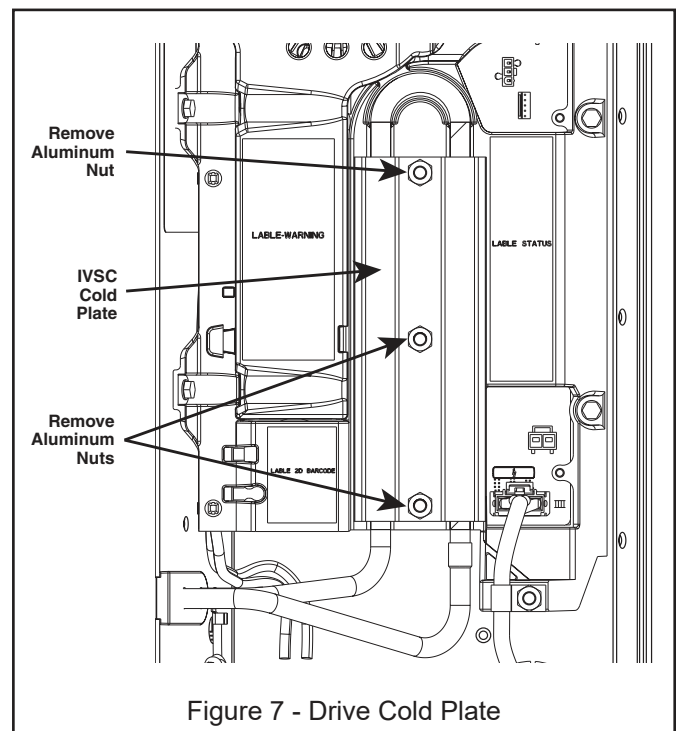

Figure 7 - Drive Cold Plate

## Replacement Drive

- Using a clean, dry cloth carefully wipe away any existing thermal grease from the copper tubes. Support the tubing at all times and take care not to bend or twist the tubing.

### 4.4 - Remove the Drive

- Remove the screws securing the drive in place (See "Figure 8 - Drive Screw Locations"). When removing the final screw, support the drive with one hand.

USE CARE AND DO NOT ALLOW THE DRIVE TO SLIP AND DAMAGE THE LIQUID LINE.

- Remove the drive by sliding it up and away from the cabinet housing.

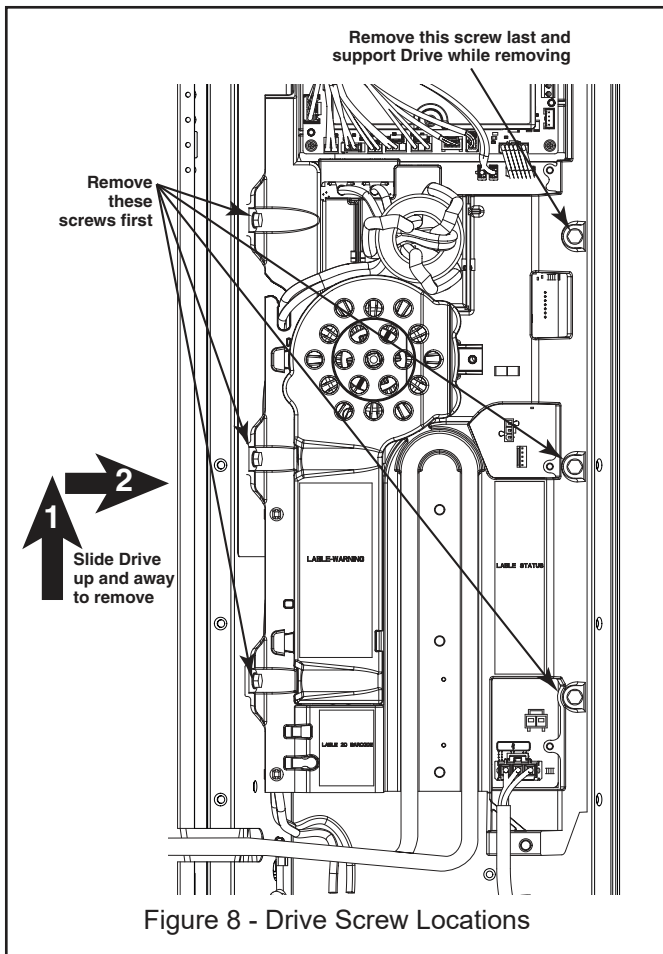

## Section 5. Apply Thermal Grease

To apply the Thermal Grease, the drive should be positioned so that the plastic cover is facing down and the cutout for the Liquid Line is facing up.

It is critical that the copper Liquid Line has good thermal contact with the aluminum plate. Proper application of Thermal Grease will ensure this contact.

Apply a small, 1/8" bead of Thermal Grease in the center of the cutout around the entire length. It takes very little grease to create adequate thermal transfer. The included .5-ounce tube contains enough grease for 2-3 applications. See Heat Sink Detail.

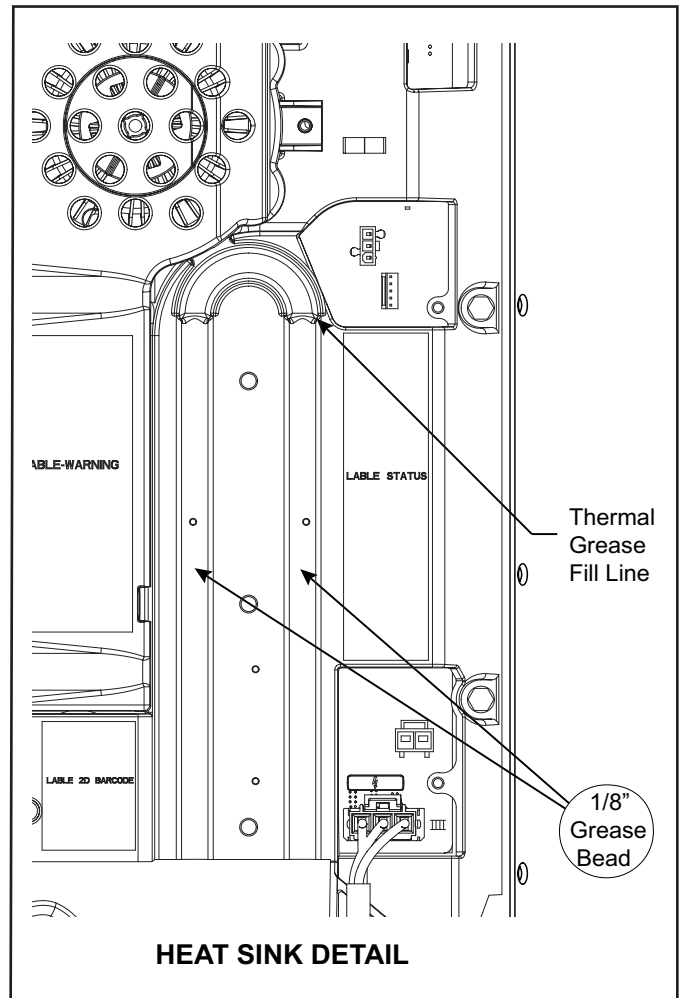

## Section 6. Reinstall the Drive

### 6.1 - Return the Drive to the Cabinet Housing

1. Place the Drive back in its original position by sliding it between the Liquid Line and the cabinet housing.
2. While holding the Drive firmly against the cabinet with one hand, replace the top right screw first. Tighten this screw by hand, enough to secure the Drive to the cabinet but still allow the Drive to move.
3. Verify that all wiring harnesses and wires are out of the way and that none of them are pinched between the Drive and cabinet housing.
4. Align the screw holes and replace the remaining 5 screws and tighten by hand with a 5/16" nut driver.

### 6.2 - Reattach Wiring

Refer to Figures 4, 5 and 6 for location of sensors and harnesses and reattach the connectors to the AOC and MOC. While the order in which you reattach the wiring is not significant, you may find it easiest to start in the upper left hand of the AOC and move down and then right.

### 6.3 - Position the Liquid Line

1. Align the Liquid Line with the cutout on the drive.
2. Locate the rubber grommet that protects the Liquid Line from the sharp edges of the cabinet housing. Push the rubber grommet into the notch in the housing so that it is flush with the edge of the cabinet and the grommet is seated securely around the Liquid Line.
3. Position the Cold Plate over the Liquid Line and slide it over the bolts.
4. Place the 3 aluminum nuts on the bolts and hand tighten 2-3 turns.
5. Press the Liquid Line into the cutout so that it is properly aligned and seated into the cutout. Apply pressure to the Cold Plate and finger tighten the aluminum nuts. Repeat this process 3-4 times to ensure the Liquid Line is firmly seated in the cutout. You should see the Thermal Grease begin to flow around the copper tubing.

**NOTICE:** Use only the aluminum nuts that were on the unit originally or those that shipped with the Replacement Kit.

### 6.4 - Tighten the Aluminum Nuts

Using a torque wrench, tighten the aluminum nuts to 40-50 in. lbs. of torque.

**CAUTION.** The aluminum nuts are designed to strip out at 80 in. lbs. **DO NOT OVERTIGHTEN.**

If you do not have a torque wrench, finger tighten the nuts as described above. With a felt tip marker, mark a position on the nut at 12 O'Clock and turn the nut to the 5 O'Clock position. See "Figure 9 - Tighten Aluminum Nuts".

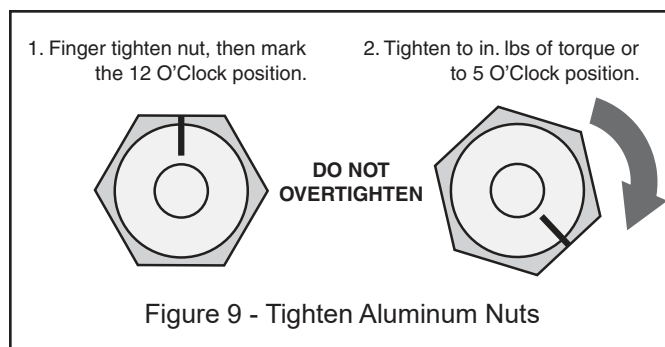

Figure 9 - Tighten Aluminum Nuts

### 6.5 - Reattach Compressor Wiring

1. Plug in the Compressor plug to the connector at the bottom of the Drive.
2. Reattach the shielded harness ground wire to the drive assembly.

## Section 7. Perform Final Inspection

1. Verify that all wires and plugs are reconnected and that no wires are pinched between the Drive and the Cabinet Housing.
2. Start up Unit and verify operation.
3. Reattach the shielded harness ground wire to the drive assembly.
4. Verify that the Line Set Cover is in place.

## Section 8. Return Drive Board

1. Package the failed control and return to your local parts center.

**NOTE:** To receive Factory Credit for failed Drive Boards covered by the Limited Warranty, a valid pre-authorization number is required. Be sure to mark the box and the service invoice with the pre-authorization number before returning to your local parts center.

## About Trane and American Standard Heating and Air Conditioning

Trane and American Standard create comfortable, energy efficient indoor environments for residential applications. For more information, please visit [www.trane.com](http://www.trane.com) or [www.americanstandardair.com](http://www.americanstandardair.com)

---

The manufacturer has a policy of continuous data improvement and it reserves the right to change design and specifications without notice. We are committed to using environmentally conscious print practices.

18-BC113D1-1C-EN 13 Dec 2024

Supersedes 18-BC113D1-1B-EN (May 2024)

© 2024