

TRUFROST & BUTLER

USER MANUAL

**Floor Standing 32 Litre Double Tank
Electric Fryer with 2 Baskets:
Wonderfry-16.2E**

I .Introduction:

EF Series Fryer is a new kind of electric thermal products researched and developed lately by our company. This series fryer adopts the international popular style design, good quality of stainless steel body, luxurious and good-looking. The products are equipped with electrical elements from the famous factories so that they are energy-saving and safe. The featured design as rotating the fryer head, convenience, practicality and clean easily. Be provided with thermostat function, operate briefness. It is the best choice for hotels, bars, and west-style food shops, etc.

II.Technical Specification:

Model	Voltage	Input Power (KW)	Capacity (L)	Dimension (mm)
Wonderfry 16.2E	230v/50hz	5+5	16x2	740*550*800+110

III.Operating Instruction:

Before use, please check whether the voltage of power supply is in conformity with that in date plate, and whether user's power switch and fuse are in conformity with the request of machine's power. The body must be earthed properly. Make sure the potential terminal bolt is firmly connected with the natural grounding device by the 1.5mm² wire.

Operation Step:

1. Fill edible oil into oil tank and oil deepness must be kept on the range of oil tank marked with the height and the low.
2. Turn the thermostat on "0" position, cut off the time switch power supply.
3. Connect with fryer's power supply and green power indicator is on. Turn the power of the machine on and adjust temperature control to suitable temperature in clockwise; at this time, yellow indicator is on and thermal tubes begin to heat. When oil temperature reaches setting data, temperature control is power-off, yellow indicator is off, and thermal tubes stop working. When oil temperature is down a little, temperature control connects power supply automatically, yellow indicator is on, and thermal tubes begin heating again. This procedure is circulating repeatedly to ensure oil temperature keep on set temperature range.
4. There is a special fried basket attaching the fryer, and a hook is on the basket. When you fry the food, take it into the basket and sink into the oil. When you fry the food, please hang the basket on the nail of the electric control box in order to filter the surplus oil.
5. The cover of oil jar is designed to make the jar clean and warm. Pay attention to making sure that there is no water on the cover when you cover.
6. After finish frying, turn over electric control box backward, rotate it 90°, then electric control box self-locks on vertical position, so that it can recycle the oil on thermal tubes and net.
7. The fryer is equipped with the safe switch. When you lift up the electric control box, the thermal tubes will be out of the oil automatically. Then the safe switch will take action to cut off the power. It can avoid the dangerous accident as a result of the mistaken operating. You may rotate the valve in front of the fryer or take out the oil tank from the frying box, which will be helpful to pour out the oil inside the tank. (Please pour out the oil as the oil is cooled to room temperature.)
8. When you finish the frying, you should rotate the temperature controller to the Zero limited position in contrary clockwise. At the same time, the power should be cut off for safety.

IV.Maintenance and Maintain:

After use, you should use a wet cloth to clean in time, or use neutral vinegar to clean if necessary, but electric control box is forbidden to use water to rinse.

V.Note:

It is forbidden to put the tinder and explosive nearby the machine. And keep it in the environment with the superior ventilation system. Moreover, forbidden to make heating tube dry-burning in order to prolong machine's service lifetime. When use the fryer, can not close it if not the worker guy, and do not let the children to touch the oil jar and oil out valve as well; In order to avoid the accident, you must unplug the power supply cord or cut off power switch if you have not used the machine for a long time. All the service and maintenance operation must be carried out after the power supply is cut off. If there is some trouble in fryer, do not dismount the machine, and send it to our company's authorized service department or distributor for repair.

Warning: use old oil will lower flash point, will cause over boil easily; it will occur fire insurance easily when the oil line lower than he lower limit line; fry over-wet food and over fry will possible cause contingency.

PACKING LIST OF LEAVE FACTORY

Model	Electric Fryer	Frying Basket	Cylinder Head	User Manual	Inspection Certificate
Wonderfry 16.2E	1	2	2	1	1

VI.Circuit Diagram:

SA1: Power Switch

ST2: Limit Temperature

EH: Electric Heating Pipe

SA2: Timer Switch

HL1: Power Indicator

KT: Time controller

SA2: Safe Switch

HL1: Power Indicator

KM: Power Relay

ST1: Temperature Controller

HL2: Heating Indicator

KM: Power Relay

ST1: Temperature Controller

HL2: Heating Indicator

SA1: Safe Switch

ST2: Limit Temperature

EH: Electric Heating Pipe

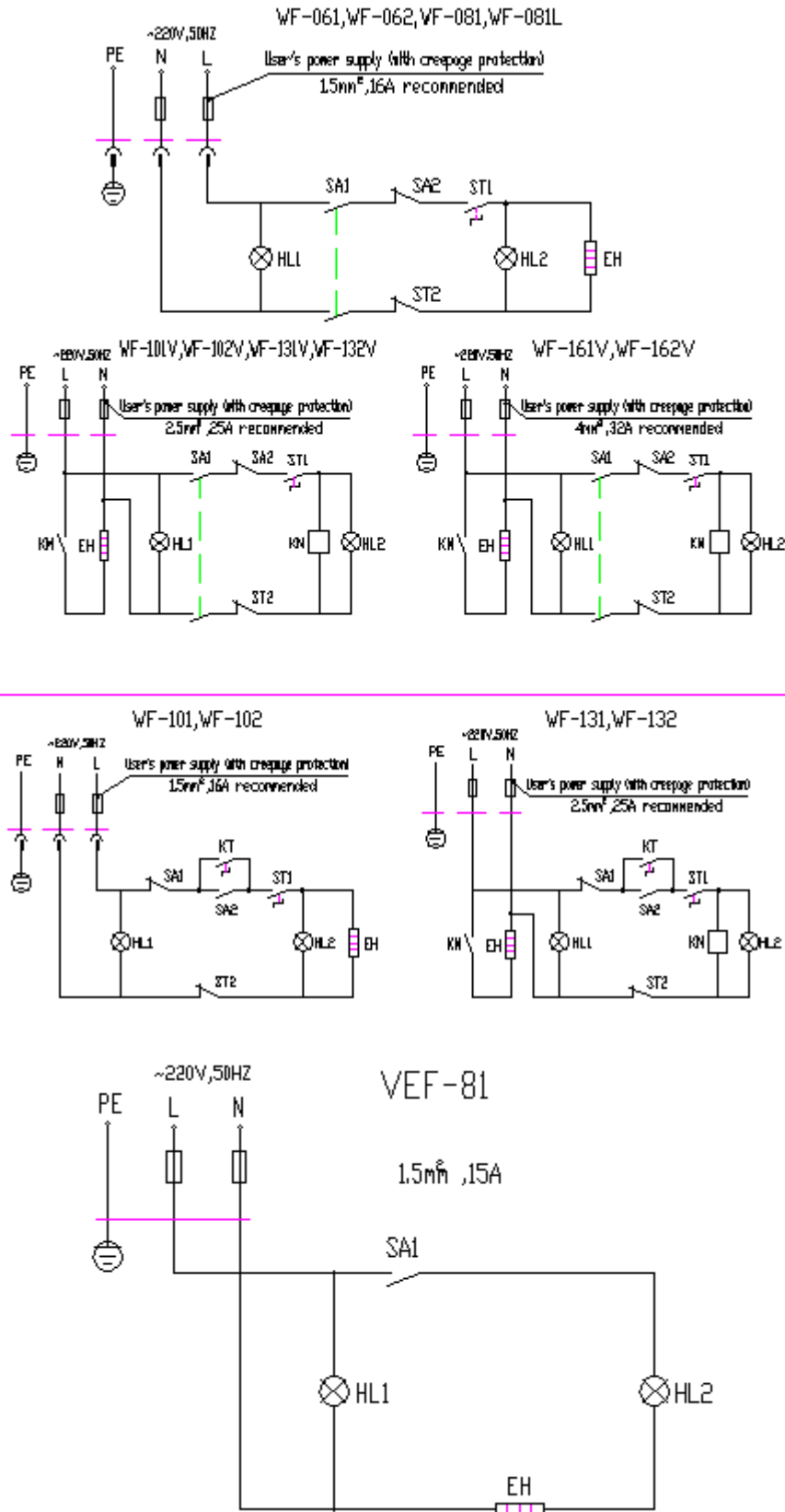

Marketed globally by:

TRUFROST AND BUTLER PRIVATE LIMITED

1215, 12th Floor, Tower B, Emaar Digital Greens, Golf Course Extn. Road, Sector 61, Gurugram – 122011 (India)

T. +91-7303166766 info@trufrost.com

www.trufrost.com