

**TRUFROST & BUTLER**

# **USER MANUAL**

**Gas Deck Oven with Digital Control**

**GDO 1D-2T Black Italia**

**GDO 2D-4T Black Italia**

**GDO 3D-6T Black Italia**

**(Please read this manual carefully before using the product)**

## **Black Italia Series Gas Deck Ovens & Pizza Ovens**

- **Thank you for purchasing our products**
- **Please pay attention to the instructions before using this product**
- **Please read this manual properly and keep it safely for future reference**
- **Due to the continuous improvement of our products, they are subject to change without prior notice**

### **Tips:**

- ❖ **Do not leave the gas appliance unattended when in use, this will prevent liquefied gas leakage and explosion caused by flameout.**
- ❖ **After each use, the cylinder and gas appliance switch must be turned off.**
- ❖ **The gas appliance switch must be in OFF mode before you switch on the gas supply and ignition. Before using the appliance make sure you know how to adjust the damper and handle all emergencies.**
- ❖ **If you notice strong pungent gas smell during work, it means that gas oven is not ON properly. Please adjust the damper suitably to avoid any serious harm**

## **I Introduction of Product Functions**

Commercial box-type gas oven series is developed by the Company and designed by absorbing the advantages of similar products at home and abroad. This equipment uses gas for heating, adopts constant temperature control system and is equipped with flameout protection safety device, so that the baked food will not appear partially uncooked and partially overcooked, and the temperature will rise rapidly, with uniform heating and good heat preservation performance. This product has the advantages of novel style, reasonable structure, durability, convenient operation and easy maintenance, and it is the ideal equipment for pedestrian street, commercial street, restaurant, canteen and food industry.

## II Structural Schematic Diagram

### 2.1 Structural Schematic Diagram (the product and the pictures are for reference only)

Schematic Diagram of Single-layer Structure:

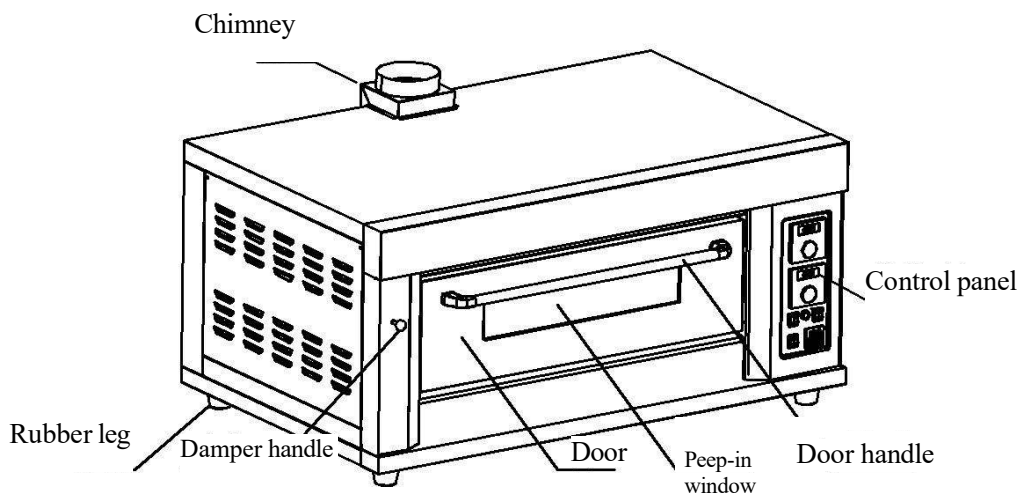

Schematic Diagram of Two-layer Structure:

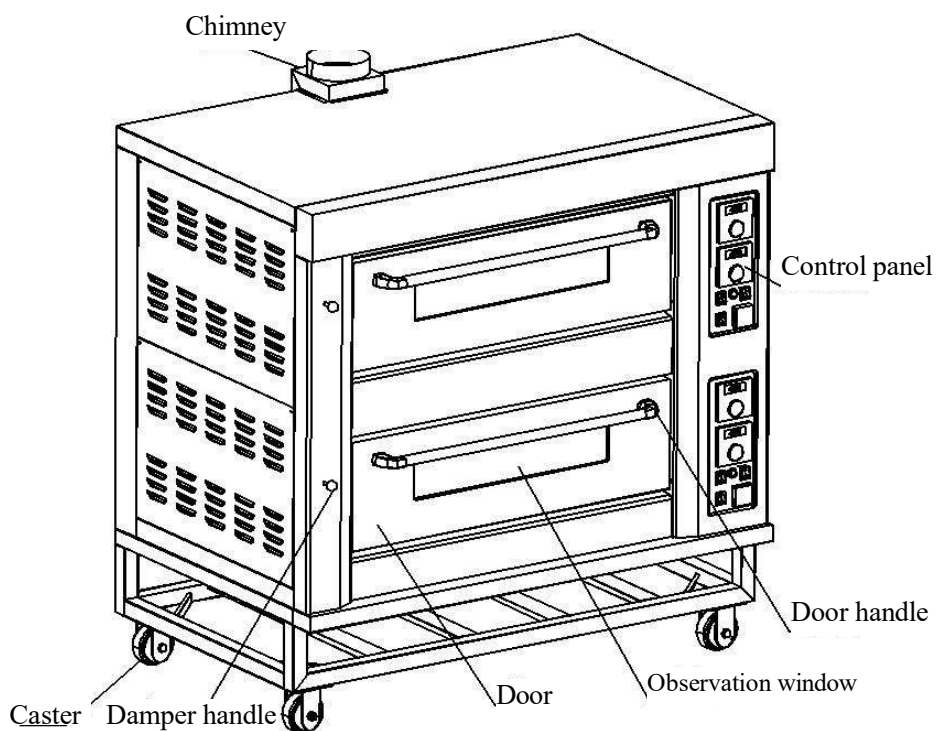

## Schematic Diagram of Three-layer Structure:

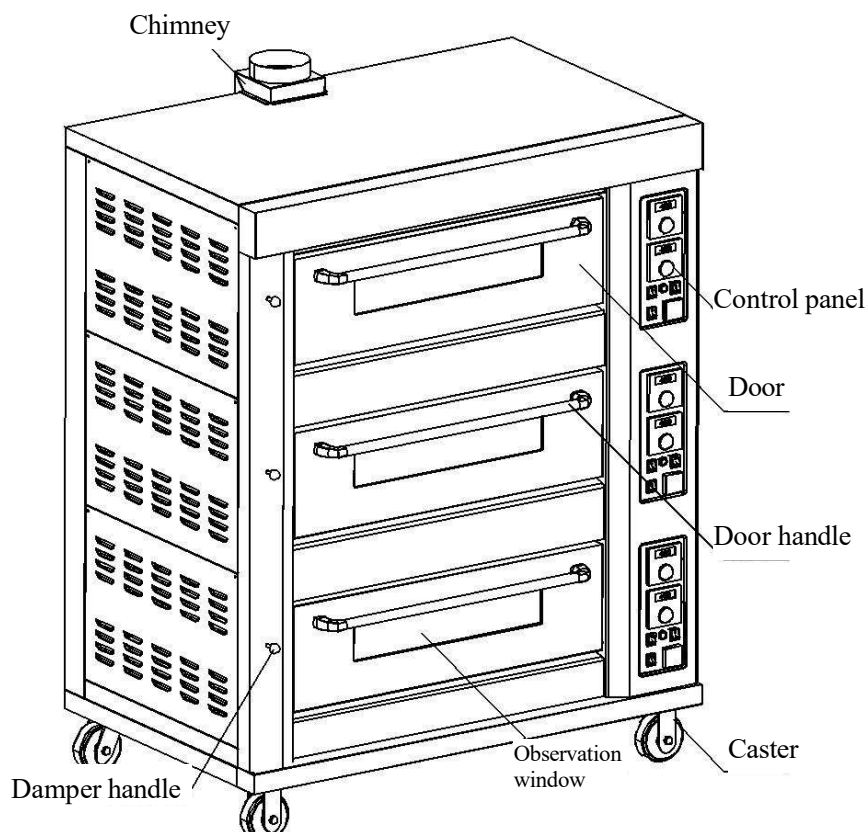

## 2.2 Structural performance characteristics:

- 1 The gas oven comes in one, two or three deck options.
- 2 It adopts liquefied petroleum gas as the heating source. Blast combustion mixes the gas and air in the correct proportion and forces them into the combustion tube in the furnace for full combustion and uniform heating.
- 3 With a reliable temperature control display device, the cabinet temperature can be set up to 400 degrees C. After the set temperature is reached, the system will automatically stop working, and after the temperature drops, the system will automatically ignite and start again.
- 4 The oven door is equipped with glass windows and special lighting inside is convenient for observing the status of the food baking in the oven.
- 5 The top and bottom temperatures of each layer can be controlled separately.
- 6 Independent combustion tube is made with specially treated heat-resistant material.

- 7 Equipped with flameout protection device in case of power failure, gas exhaustion or any other fault causing sudden flameout, "ZC" flame detection system will immediately monitor the flame state, automatically cut off the power supply, close the gas pipeline and sound an alarm.
- 8 Independent ventilation and air supply device effectively dilutes the gas in the residual oven until it can't burn, and forcibly blow it out acting as a safety protection.

### III Basic Product Parameters

#### 3.1 Technical Specifications of Computer-controlled Deck Type Gas Ovens:

Model	Size and specification (mm)	Voltage	Power W	Gas category	Gas pressure Kpa	Gas consumption Kg/h	Weight Kg	Temperature control range
GPO-36 Black Italia	1060×675×64 0	220V	100	Liquefied petroleum gas	2.8	0.18	65	0~400°C
GPO-36 – 2D Black Italia	1060×675×11 50	220V	200	Liquefied petroleum gas	2.8	0.36	120	0~400°C
GDO 1D-2T Black Italia	1330×840×650	220V	100	Liquefied petroleum gas	2.8	0.28	102	0~400°C
GDO 2D-4T Black Italia	1330×840×1355	220V	200	Liquefied petroleum gas	2.8	0.58	170	0~400°C
GDO 3D-6T Black Italia	1330×840×1670	220V	300	Liquefied petroleum gas	2.8	0.88	230	0~400°C

#### 3.2 List of Parts:

Part name	Quantity
Low pressure valve	1 set
Manual	1 copy

## IV Precautions

### 4.1 Transportation and storage

During transportation, the machine shall be handled with care, and it shall not be inverted to prevent damage to the product shell and the inside. The packaged machine must not be stored in open air and it needs to be in a warehouse with good ventilation and no corrosive gas.

### Installation and precautions

1. During handling and installation, protective measures must be taken by relevant personnel.
2. If you notice damage to the packaging, immediately check for any damage to the equipment or any missing parts. In case of any damage please call the relevant personnel and do not use the equipment.
3. Please check equipment size and see if it can pass through the passage smoothly before handling the equipment.
4. When loading, unloading and transporting, strictly follow the packaging and transportation instructions, and it is not allowed to pull or bind any electrical components.
5. When loading, unloading and transporting, the equipment shall not be placed upside down or stacked. Pay attention to prevent the shelf and door in the shell from moving during handling.
6. The equipment shell must be placed horizontally. Please fix the casters to prevent the shell from moving, and pad the casters according to the ground conditions to keep the shell horizontal.
7. When installing, the left and right sides of the equipment shall be more than 30cm away from combustible materials, and the back shall be more than 50cm away from combustible materials (such as brick walls and windows). It shall not be installed on flammable floors or materials.
8. The installation location must be a well-ventilated place with adequate exhaust facilities to ensure steam discharge.
9. After installation, the equipment must be kept stable and placed horizontally, and shall not tilt.
10. The power supply voltage must be consistent, in case of voltage fluctuation, use a

voltage stabilizer

11. Before installation, please check if the voltage is normal, the safe Earth connection and there is no loose wiring.
12. Flammable and explosive articles must not be stored near the equipment.
13. The equipment shall not be stored and used in the open air, nor used in wet places.
14. The installation of the machine and the conversion of gas must be carried out by authorized professional technicians according to all the regulations.
15. Do not use other gases that do not meet the equipment requirements as fuel or use high-pressure valves. (This equipment works on low-pressure regulating valves)
16. Before installing the equipment, a quick cut-off valve must be installed, which must be placed in the upstream position near the equipment and is easy to access.
17. Please ensure that the gas used by the equipment is high-quality liquefied petroleum gas, anything else will block the nozzle.

#### 4.2 Special precautions

1. The equipment should only be operated in strict accordance with the product specifications and the special warning sign on the gas oven.
2. The type of power supply (rated voltage and frequency) and applicable gas source (gas type and rated gas pressure) must be consistent with the nameplate on the machine.
3. The power supply and air supply must be completely turned off when any accessories are being replaced or the equipment is being repaired.
4. The power cord of this machine must be connected to the power socket with leakage and overload protection device and must be connected with the protective ground wire. If there is no protective ground wire on the power socket, the oven shell must be firmly connected with the
5. self-made ground wire that meets the standard with a wire of more than 2.5m<sup>2</sup>.
6. One end of the special hose for liquefied petroleum gas is connected to the relief valve of the liquefied petroleum gas cylinder, and the other end (of the special relief valve of the Company) is connected to the air inlet interface in front of the oven. The interface must be firmly fixed with steel hoops, and there shall be no gas leakage.
7. The accessories such as liquefied petroleum gas cylinders, hoses and relief valves used must comply with the provisions of national safety standards. Qualified

liquefied gas cylinders, relief valves and rubber hoses must be used, and the outside of the rubber hose must be protected with iron hoses to prevent gas leakage caused by rat biting or bumping. The liquefied gas cylinders must be placed in a safe zone and min. 2m away from the oven.

8. There should be adequate air circulation where the equipment is used, and smoke exhaust pipes must be installed at the smoke outlet of the oven to ensure that the combustion waste gas can be effectively discharged outdoors; One side of the electrical box of the equipment must be open and vacant, so as to ensure sufficient air supply in the burner of the oven for combustion.
9. After the installation is completed, open the angle valve of the gas cylinder to make the gas fill the pipeline of the oven, and apply soap foam with water to the interfaces between the gas cylinder and the input pipeline for inspection. Only after confirming that there is no leakage can the equipment be used
10. When using it, if the ignition time is long, because there is air in the newly installed pipeline and it fails to ignite for three consecutive times in the cold box, suspend the ignition to find the reason immediately or wait for more than 5 minutes to ensure that the accumulated gas dissipates naturally before re-ignition; At this point, open the equipment electrical box cover (box side plate), adjust the fan damper properly, and then ignite.
11. Please cut off the power supply and turn off the gas cylinder angle valve, if a strong gas smell is coming while using it. If this happens, be sure not to move any electrical switches, open the window to let the leaked gas out. After the fresh air is circulated, call authorized and trained technician to check and eliminate the source of leakage before the equipment can be used.
12. The air volume of the fan must not be too little after the burner is ignited, otherwise it will cause incomplete combustion, which will lead to exhaust gas entering the work space with the opening of the equipment box door, causing accidents. Please lock the casters to prevent the oven from moving and pad the casters according to the floor conditions to keep the oven horizontal.
13. If no operator is available and the equipment is not being used, it must be turned off to avoid danger.
14. Do not disassemble or modify the equipment.

15. Do not place heavy objects on the oven.
16. Do not touch the machine directly with your hands during, before and after use. It will cause burns.
17. Do not use water jet for cleaning. Clean the stainless steel surface properly and regularly to prevent surface oxidation that will damage the equipment.
18. After use, turn off gas valve immediately.
19. The gas valve shall be closed immediately, if gas leakage is detected and the door should be opened for ventilation. Use the equipment only after the leakage has been repaired.

## **V Operation Instructions**

1. Connect the pure liquefied gas source as specified. Check if the upper and lower steel pipes, liquefied gas cylinders, low-pressure relief valves and hoses have any leakage and are in good condition, and use them only after no defect is found.
2. Check whether all valves of the equipment are closed and ensure that all valves that are not screwed off fully are closed.
3. Be sure to connect the power cord with AC220V with leakage protection switch, and ensure the ground wire connection is firm.
4. Open the gas regulating valve to make sure there is no gas leakage.
5. Switch on the power supply check that and the digital temperature controller displays properly; Switch on the lighting lamp and then turn on the timer switch, to display the timer properly. Then check whether all electrical appliances work properly.
6. After checking that all electrical appliances work properly, open the gas valve, rotate the digital temperature control switch to adjust to the temperature suitable for baking, and observe whether the pulse igniter is ignited properly.
7. The top and bottom temperature can be controlled separately. First, set the temperature of "upper fire" or "top fire". Rotate the digital temperature controller clockwise, align the required temperature value with the scale position, adjust the top digital temperature controller by "top fire heating" and the bottom digital temperature controller by "bottom fire heating", and select the appropriate temperature according to different foods you are making.
8. Adjust the digital temperature control switch to the required temperature, and the

pulse igniter will ignite. Note: Each ignition shall last about 8-10 seconds. If it takes longer, the solenoid valve will automatically close, the igniter will give an alarm and the alarm light will be on. Please turn off the ignition switch and try again. If the ignition is unsuccessful for two consecutive times, turn off the temperature control switch, open the door, ventilate for 15 minutes and then re-ignite.

9. When the temperature in the oven reaches the set temperature, the pulse igniter will stop working, the burner will stop burning, and the machine will enter a constant temperature working state; When the temperature drops than the set temperature, the pulse igniter will continue to ignite, the burner will automatically ignite and burn, and the oven will start to heat up again.
10. Flame state: The flame can be observed through tempered glass. It should be strong and stable, and relatively short, which is the normal combustion state. For the adjustable oven, if the flame is light yellow, it indicates insufficient air volume, and the corresponding fan damper shall be opened a little; However, when the flame is intermittent or blue-white, or even flameout, it indicates fluttering and unstable flame due to excessive wind, and the damper shall be turned down a little.
11. Check the liquefied steel cylinder, relief valve, hose and connection port for damage and air leakage at any time during work and pay attention to the indoor air condition.
12. After use, first close the master gas valve, and then close the individual valves to ensure that the gas source is closed.
13. Warning: Do not use spray water to rinse the oven directly to avoid failure.
14. When using the oven for the first time, there will be odor in the oven. It is suggested to bake a plate of onions in the oven first, and then bake other foods after the odor is gone.
15. Please observe the new machine for a few days before use to get familiar with the performance of the equipment as well as to check if any problems are found. Be sure to inspect when installing the new machine if any screws became loose during transportation.
16. Bring the oven to the required temperature before putting food into the oven so as to avoid frequent opening and closing of the door. After baking, be sure to take out the baking tray and food with protective gloves to avoid burns.

17. Avoid installing an exhaust fan above or in front of the oven door.
18. In case of uneven heating during use, it can be solved by adjusting the tray
19. After use, the machine shall be powered off for maintenance, and the baking tray shall be cleaned regularly and at least once a day.

Note: In order to avoid the danger caused by the wrong reset of the thermal circuit breaker, the appliance shall not be powered on through an external switching device (such as a timer) or be connected to a circuit that is regularly turned ON and OFF by a common component.

## VI Precautions:

The product is sensitive to voltage fluctuation so using a voltage stabilizer is a pre – requisite to avoid damage to the equipment. In order to ensure effective usage of the product, please use the gas low-pressure relief valve configured by the Company.

## VII Fault Analysis and Troubleshooting

Fault	Cause	Troubleshooting
Non-ignition	<ol style="list-style-type: none"> <li>1. Igniter damage</li> <li>2. Solenoid valve damage</li> <li>3. Ignition needle is not in the right position.</li> <li>4. Ignition needle damage</li> <li>5. Insufficient pressure of liquefied gas cylinder</li> <li>6. Large air intake</li> <li>7. High voltage ignition wire damage</li> <li>8. Temperature controller damage</li> <li>9. Line fault (burnt out)</li> <li>10. There are foreign matters at the joint between the ignition needle and the ignition wire</li> <li>11. Gas valve does not match</li> <li>12. Fan does not run</li> </ol>	<ol style="list-style-type: none"> <li>1. Replace the igniter</li> <li>2. Replace the solenoid valve</li> <li>3. Adjust the position of the ignition needle until arcing</li> <li>4. Replace the ignition needle.</li> <li>5. Replace the gas cylinders that are flush or heated with hot water</li> <li>6. Reduce the air intake of the fan</li> <li>7. Replace the ignition wire</li> <li>8. Replace the temperature controller</li> <li>9. Check and repair the line</li> <li>10. Remove the foreign matters around and eliminate the possibility of short circuit</li> <li>11. Adopt the valves equipped by our factory</li> <li>12. Replace the fan</li> </ol>
Strike arc after it fails to ignite	<ol style="list-style-type: none"> <li>1. Igniter damage</li> <li>2. The bottom line of FBT(Fly back Transformer) is not connected properly</li> </ol>	<ol style="list-style-type: none"> <li>1. Replace the igniter</li> <li>2. Connect the bottom line of FBT (Fly back Transformer)</li> </ol>

Sudden flameout at work	<ol style="list-style-type: none"> <li>1. Air intake is too large or too small</li> <li>2. Gas cylinder runs out of gas</li> <li>3. Igniter or solenoid valve damage</li> </ol>	<ol style="list-style-type: none"> <li>1. Reduce the air intake</li> <li>2. Replace the gas cylinder</li> <li>3. Replace the igniter or solenoid valve</li> </ol>
After ignition, it goes out	<ol style="list-style-type: none"> <li>1. Induction needle is not in the right position</li> <li>2. Induction needle damage</li> <li>3. Igniter damage</li> <li>4. Excessive wind</li> </ol>	<ol style="list-style-type: none"> <li>1. Adjust the position of the induction needle in the flame so that the flame can contact the induction needle</li> <li>2. Replace the induction needle</li> <li>3. Replace the igniter or solenoid valve</li> <li>4. Turn down the damper</li> </ol>
Fail to control the temperature automatically	Temperature control switch damage	Replace the temperature control switch
The shell feels like electric shock	The safety ground wire is connected properly	Check whether the ground wire is firmly connected
Power indicator is not on	The main power supply is Connected Power switch fault	Check whether the main power supply is connected Replace the power switch
If it is connected, it stops working if the temperature does not reach the set value	Temperature probe damage Temperature controller damage	Cut off the power supply, and replace the temperature probe or temperature controller after the machine cools down
The lighting doesn't work	Light damage or damage lighting	Replace the light bulb first and then replace the control switch
Display "HHH"	The temperature of the machine exceeds the instrument range Poor contact of thermocouple Thermocouple damage Digital temperature controller damage	Adjust the temperature of the machine to the normal temperature before use Compact and tighten the thermocouple wiring Replace the thermocouple Replace the digital temperature controller

The above-mentioned fault items are for reference only. If a fault occurs, stop using the oven immediately and notify professional technicians for inspection and repair as soon as possible. Repair must be carried out when the power supply and gas source are turned off.

## VIII To Users

Customers are not allowed to return or replace the commercial box-type gas oven for any reason. After opening the packaging, read the product specifications carefully and follow the operation instructions, otherwise the losses caused will be borne by the customers themselves. The right to reframing the products belongs to the manufacturer due to continues research and development, and the products are subject to change without prior notice!

### Circuit Diagram of Gas Oven:

The circuit diagram of single-layer gas oven is as follows:

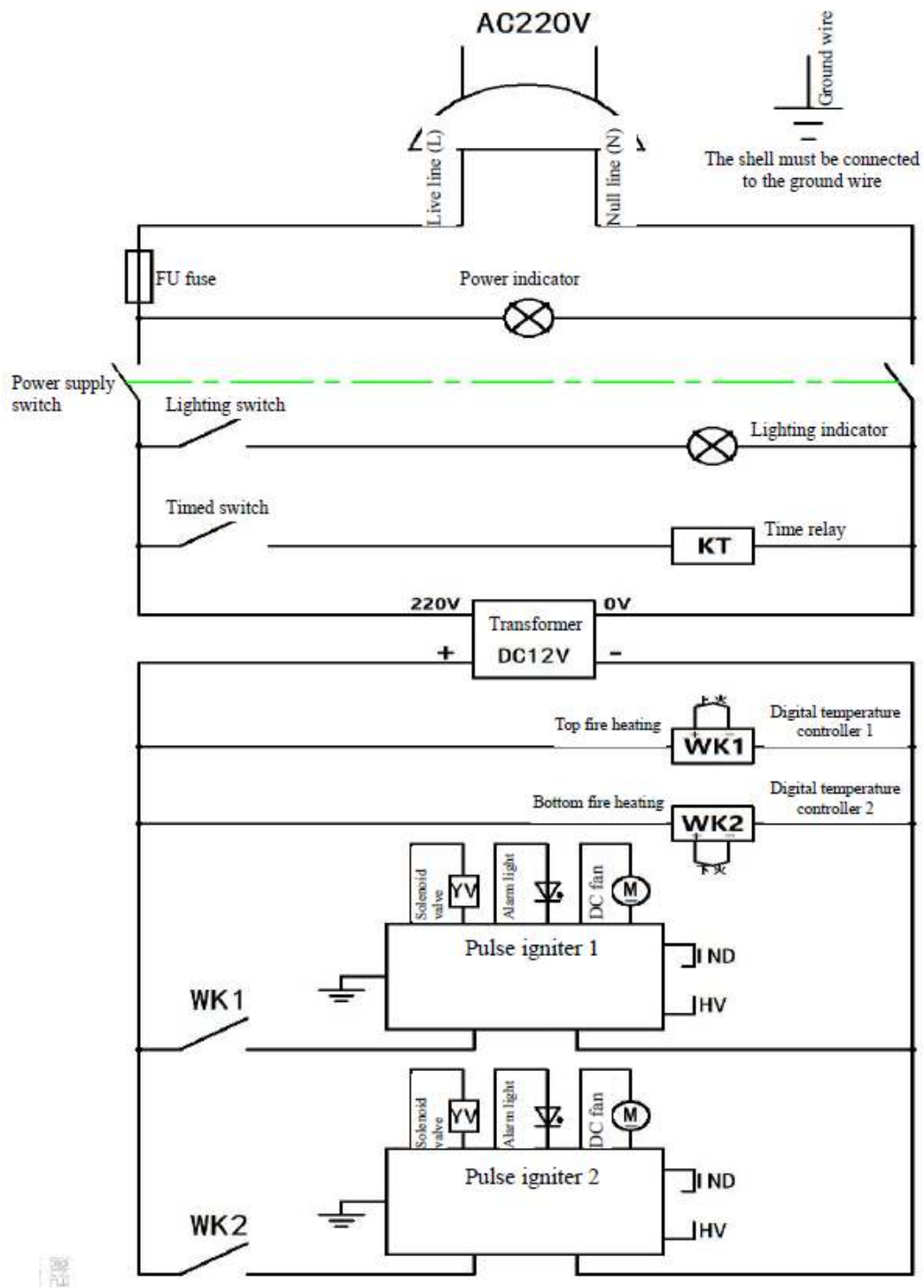

Computer-controlled operation instructions:

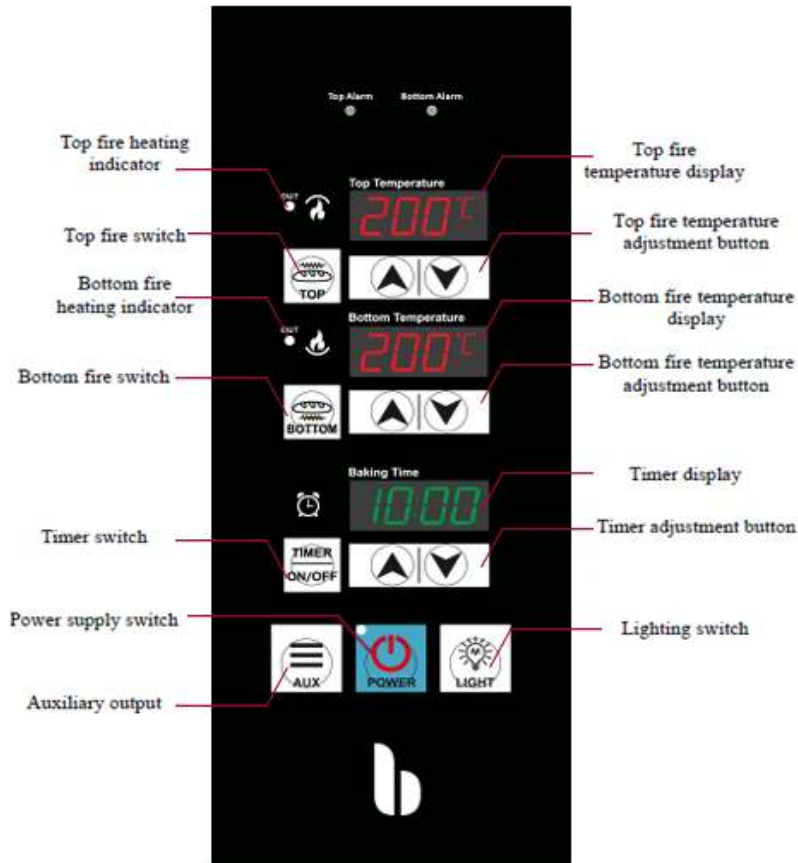

The electrical wiring diagram of the computer panel is as follows:

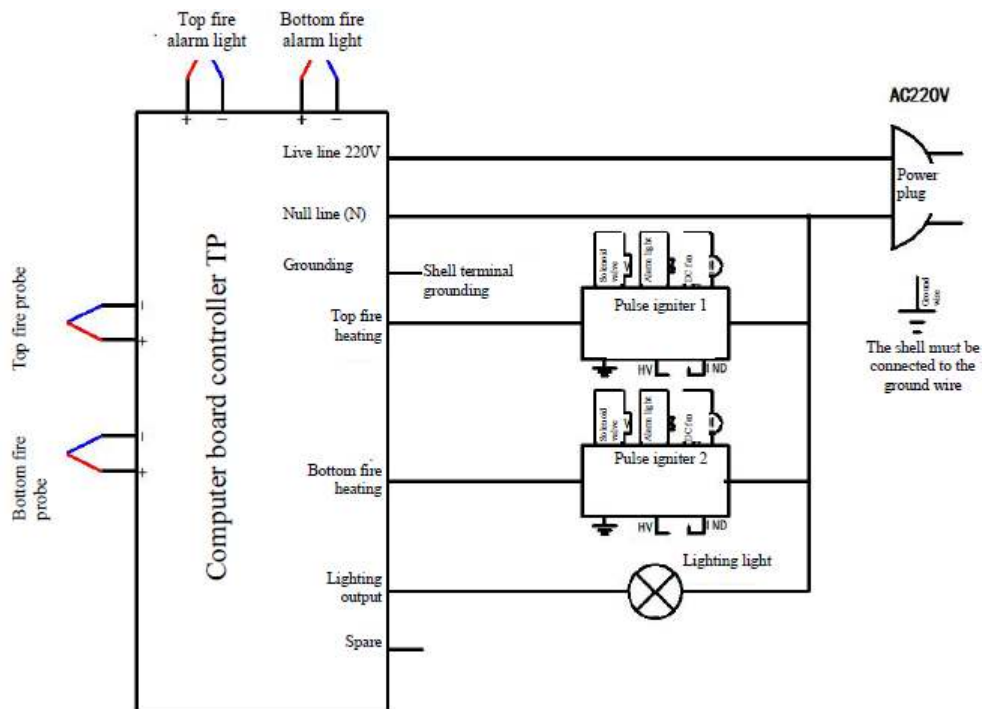

## Warranty

Note: Within one year from the date of purchase, if there is any quality problem with parts or the whole unit of our company's ovens, we will provide free repair (not including the fragile and consumable products such as lighting bulbs and oven door glass). This warranty certificate will be invalid if it is altered.

1. According to the national regulations, our company and distribution network provides warranties for the product.
2. The product warranty period is 12 months from the time of purchase.
3. Warranty will be invalid, if the oven is not installed and used according to the operation manual or damaged due to collision during transportation.
4. In case of oven failure, the user shall inform the authorized service technicians immediately.

All expenses incurred outside the scope of warranty shall be borne by the user.

5. The user must fill in the warranty card at the time of purchase and keep this card and invoice for future repair.
6. In any of the following circumstances, the warranty will not be provided, but repair fees can be charged:

*Marketed globally by:*

**TRUFROST AND BUTLER PRIVATE LIMITED**

1215, 12th Floor, Tower B, Emaar Digital Greens, Golf Course Extn. Road,  
Sector 61, Gurugram – 122011

T. +91-7303166766 info@trufrost.com

[www.trufrost.com](http://www.trufrost.com)