

Mod.
1099

urmet

DS1099-183

WIFI 1080P IP PoE CAMERAS SERIES

BULLET
1099/212B



USER MANUAL

CONTENTS

CONTENTS	2
INTRODUCTION	3
1 PRODUCT DESCRIPTION	3
1.1 Technical specifications	3
1.2 Opening the package	3
1.3 Warnings	4
2 SIMPLIFIED EU DECLARATION OF CONFORMITY	5
3 INSTALLATION	5
3.1 1099/212B → WiFi Bullet Varifocal camera	5
4 EASYTOOL	6
5 ACTIVEX CONTROL CONFIGURATION	7
6 CONNECTION FROM OTHER WEB BROWSERS	8
7 IP CAMERA WEB PAGE CONFIGURATION	8
7.1 Live.....	8
7.2 Playback.....	9
7.3 Remote settings	10
7.3.1 Display	10
7.3.2 Network.....	12
7.3.3 Alarm.....	18
7.3.4 Record	20
7.3.5 System.....	21
7.3.6 Advanced	24
7.3.7 4G settings.....	27
7.4 Local settings	27
7.5 Output	28
8 VIEWING FROM APP	28
9 CONFIGURATION OF OTHER DEVICES	29
10 ROUTER 4G-WI-FI SETTINGS	30
10.1.1 Device status	30
10.1.2 System Settings	31
10.1.3 Quick Settings.....	37
10.1.4 Modify Password.....	37
10.1.5 STATISTICS	38
10.1.6 CONNECTED DEVICES.....	38
10.1.7 NETWORK Settings.....	39
10.1.8 Wi-Fi Settings.....	41
11 TECHNICAL SPECIFICATIONS	42
12 APPENDIX	44
12.1 FAQ.....	44

INTRODUCTION

Dear Customer,

Thank you for purchasing this product. We invite you to read this manual carefully before starting any operation. The software can be updated at any time. Consequently, the contents of this instruction manual are subject to change without prior notice.

Notes:

- IPC standard for Internet Protocol Camera.
- Select: left click.
- Double click: left click twice.
- Default IP address of the IP camera enabled in absence of DHCP: 192.168.100.101.
- Default username of the camera IP: admin (lower case); Password: admin (lower case).
- Default web port: 80. Default web port: 6066. Command port: 6060.
- To avoid IP address conflicts, it is advisable to connect and configure one IP camera on the network at a time.
- The content of this manual could be different from your current version. Please contact Urmet Technical Customer Care if you encounter problems during operations. The manual will be regularly updated without prior notice.

1 PRODUCT DESCRIPTION

URMET devices Ref. 1099/212B is a wireless/LTE IP camera which may be controlled entirely by connecting to the TCP/IP network.

1.1 Technical specifications

- High-performance CMOS sensor.
- Optimised H.264/H.265 video compression algorithms; multi-stream transmission for high-definition images on broadband and narrowband media.
- Simultaneous connection
- With integrated web server, Internet Explorer can be for real-time monitoring, setting and managing from the website.
- Mobile software based on the following platforms: iOS (iPhone), Android (Smartphone).
- Possibility to record on micro-SD card (not included) or on IP HVR/NVR device (not included).
- Remote system updates supported.
- LAN and Internet supported.
- ONVIF protocol supported.
- Various network protocols supported, such as HTTP, TCP/IP, IPv4, RTSP, UDP, SMTP, NTP, DHCP, DNS.
- LTE modem: band 1,2,3,5,7,8,20,34,38,39,40 e 41 with integrated antenna of 2dBi
- Alarm function supported on movement detection (the user can set area and sensitivity).
- Privacy area function supported.
- Wireless connection function.
- Snapshot function. Image uploading from email.
- Automatic reset function supported. Can be connected automatically in case of network interruption.

Note: the specifications of the various products may be subject to minor changes.

1.2 Opening the package

Check that the packing and the contents are not visibly damaged. Contact the retailer immediately if parts are either missing or damaged. Do not attempt to use the device in this case. Send the product back in its original packing if it is damaged.

ACCESSORIES PROVIDED

- 1 WIFI IP camera
- 1 URMET quick guide on paper
- 1 addendum OSS Notice
- 1 addendum containing safety warnings
- 2 Antennas
- 1 first installation kit containing fixing screws and/or hex wrench and/or tools for opening the device
- 2 hex wrenches

※ IMPORTANT NOTE:

Accessories may vary without prior notice.

1.3 WARNINGS

Power

- Make sure that the rating plate data corresponds to the power specifications before connecting the device to the mains.
- Arrange a suitable circuit breaker and fuse upstream of the devices.
- Disconnect power by means of the circuit breaker in the event of a failure and/or bad operation.
- The power unit is provided with the device.

Safety precautions

- Keep the device away from rain and humidity to prevent the risk of fire and electrocution. Do not introduce material (solid or liquid) inside. If this should accidentally occur, disconnect the device from the mains and have it inspected by qualified personnel.
- Never open the device. In all cases, contact a qualified personnel or authorised service centre for repairs.
- Keep the device away from children to prevent accidental damage.
- Do not touch the device with wet hands to prevent electrical shock or mechanical damage.
- Do not use the device if it should fall or the external casing is damaged. Risk of electrocution if the device is used in such conditions. Contact the retailer or authorised installer.

Installation precautions

- Avoid pointing the lens directly towards the sun or intense sources of light also when the camera is off. The subject must not be backlit.
- Do not point the camera towards reflecting objects or mirrors.
- Some lighting systems (e.g. coloured fluorescent lights) may false the colours.
- Do not arrange this device on an unstable surface, such as a tottering or slanted table. The device could fall causing injury or mechanical failures.
- Stop using the device if water or other material should penetrate inside: risk of fire and electrocution. Contact the retailer or authorised installer.
- Do not cover the device with a cloth while it is running to prevent deforming the external casing and overheating the internal parts: risk of fire, electrocution and mechanical failure.
- Keep magnets and magnetised objects away from the device to prevent faults.
- Do not use the device in presence of smoke, vapour, humidity, dust or intense vibrations.
- Wait for a while before operating a device immediately after transporting it from a cold place to a warm place and vice versa. Wait on average for three hours: this will allow the device to adapt to the new ambient (temperature, humidity, etc.).

Precautions

- Make sure that the device is intact after removing it from the package.
- Check that the working temperature is within the indicated range and that the environment is not excessively damp.
- Do not point the camera towards the sun to prevent damaging the sensor.

Cleaning the device

- Rub delicately with a dry cloth to remove dust and dirt.
- Dip the cloth in neutral detergent if dirt cannot be removed with a dry cloth alone.
- Do not use spray products to clean the device. Do not use volatile liquids (such as petrol, alcohol, solvents, etc.) or chemically treated clothes to clean the device to prevent deformation, deterioration or scratches to the paint finish.
- Disconnect the device from the mains before cleaning or maintenance.

Image recording

- This device was mainly designed to transmit and possibly record images, not as a burglar alarm. Urmet S.p.A. cannot be held liable for loss or damage following theft sustained by the user.
- Test recording before using the device to make sure that is working correctly. Please note that Urmet S.p.A. is not liable for loss of stored data consequent to loss or damage caused by incorrect installation, use, improper use or malfunctioning of the device.
- This device contains precision electronic components. Protect the device from shocks to ensure correct recording of images.

Privacy and Copyright

- The IP camera is a CCTV system device. Recording of images is subject to the laws in force in your country. Recording of images protected by copyright is forbidden.
- Product users shall be responsible for checking and respecting all local rules and regulations concerning monitoring and recording video signals. The manufacturer SHALL NOT BE LIABLE for use of this product not in compliance with the laws in force. For more information see <http://www.garanteprivacy.it>.

Firmware upgrades

- Periodically check on the URMET website <https://www.urmet.com> for firmware upgrades.

Network configuration

- The camera is set to DHCP mode. If the network on which it is installed does not support dynamic addresses (DHCP), the camera will automatically activate the default IP address 192.168.100.101. The "Easy Tool" Urmnet software can be used to change the default IP address and other network configurations of the camera to prevent conflicts with other devices on the network. Always check the warnings for restrictions concerning the address which can be assigned to the camera.

Network connections

- When connecting a PC (using Software Client or Browser), any video channel on the PC will be using "unicast" connection (TCP, RTP, UDP).
- The device can support a limited number of "unicast" connections so it is possible to show the video on maximum 4 remote devices (of which 2 smartphones at the most) at the same time depending on the available network band.

Reset button

- The camera is equipped with two Reset buttons:
- Button on the cable (press for at least 3 seconds): this can be used to reset all the factory settings of the IP camera only (e.g. camera password, video stream, image settings, motion detection, recording, etc.). It leaves the WiFi and 4G configurations unchanged.
- Button adjacent to the nano-SIM slot: this can be used to restore all factory settings for the integrated 4G/WiFi router only. It leaves the IP camera configurations unchanged.

2 SIMPLIFIED EU DECLARATION OF CONFORMITY

Hereby, URMET S.p.A. declares that the radio equipment types: camera 1099/212B, is in compliance with Directive 2014/53/EU. The full text of the EU declaration of conformity is available at the following internet address: www.urmet.com

3 INSTALLATION

3.1 1099/212B → WIFI BULLET VARIFOCAL CAMERA

It is advisable to proceed as follows for correct camera installation and configuration:

1. Make sure that the unit to be connected is not powered before starting the installation procedure. Fit each of the two aerials (black aerial for LTE, white aerial for Wi-Fi) supplied on the respective camera connector.
2. Insert the nano-SIM (not included) into the appropriate slot of the camera with the device switched off (see next image).

IMPORTANT: It is recommended to disable the SIM card PIN from your mobile phone or tablet before inserting the SIM card into the camera. If necessary, refer to section 10 of this guide to disable the PIN of the SIM already inserted in the camera.

IMPORTANT: Some mobile network operators can introduce major delays or blockages in camera connections.

3. When recording to a micro SD card (not included), insert the SD memory card into the SD memory card slot of the camera when the power is off (see next picture). Format the SD card from camera settings on the web page or from the app.

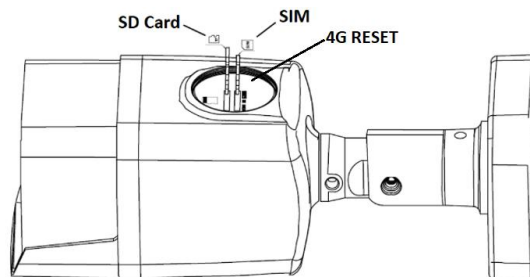

4. Place the camera in a location with good 4G signal reception and then power the camera (power supply not supplied). Within a few minutes of switching on, the camera automatically connects in 4G to the internet network.

5. To check the connection of the camera in 4G to the internet, connect a personal device such as a smartphone/tablet/PC to the Wi-Fi network of the camera (Wi-Fi SSID): "MIFI_...", Wi-Fi password: 1234567890) or connect a PC via cable to the network connector of the camera.
6. The integrated 4G/Wi-Fi router provides internet access to the camera and also to devices connected via Wi-Fi or cable to the camera.
For remote viewing of the camera from a smartphone/tablet device, see section 8 of this guide.
To access the advanced configurations of the built-in 4G/Wi-Fi router of the camera, see section 10 of this guide.

4 EASYTOOL

The software can detect the IP address of the IP camera on the LAN. Firstly, unzip the easytool.zip file contained on the CD included.

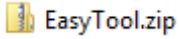

Install and run EasyTool.exe.

Start "Easy Tool" by selecting : the IP Address, Subnet Mask, Gateway and MAC Address will be automatically shown for each IP camera, as shown in the following figure.

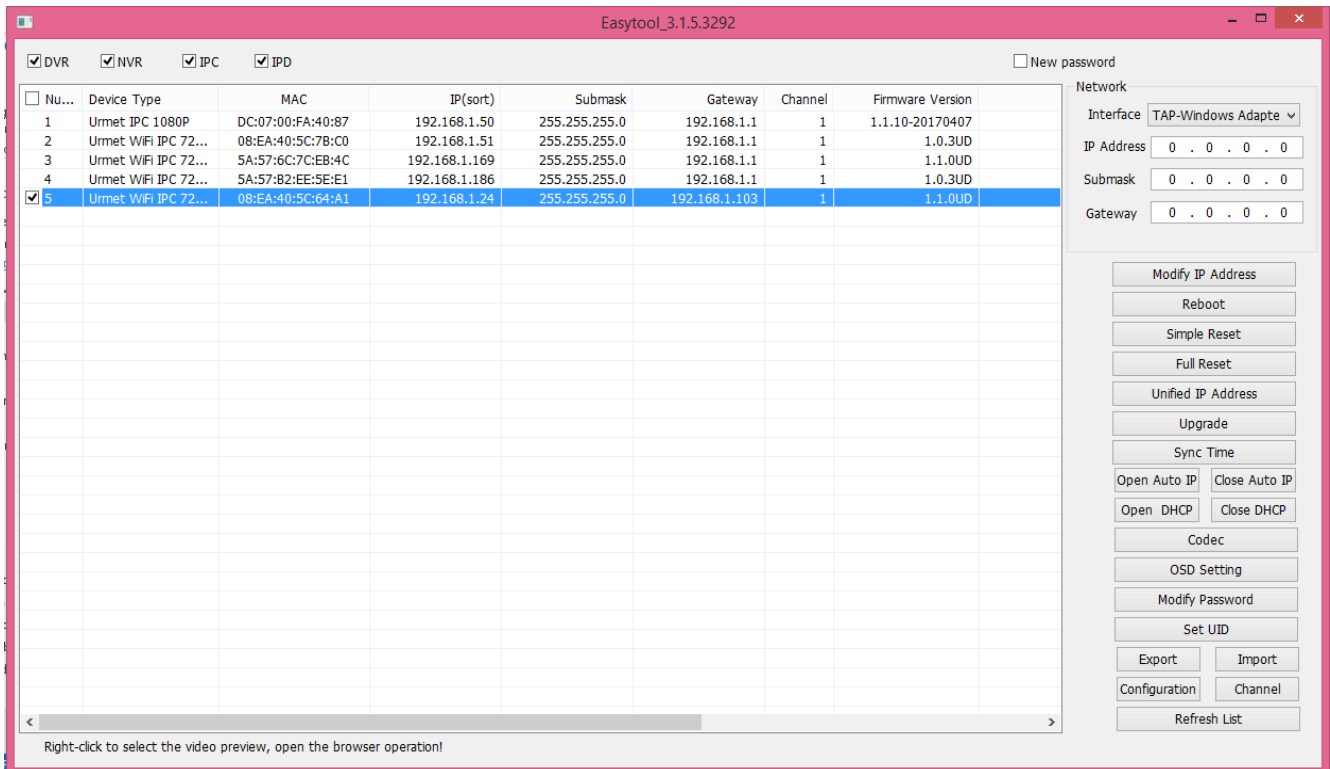

If the searched IP and the IP address of the PC are not on the same network segment, the IP address, the subnet mask and other IP camera parameters can be changed by using Easy Tool.

Firstly, select the device the IP address of which you want to change and enter the new IP address, Subnet Mask and Gateway values (Subnet Mask and Gateway may be inherited from the PC) and the username/password. Click on **Modify IP Address** to change the IP address of the device.

※IMPORTANT NOTE

The default IP address of the IP camera is "192.168.100.101", the default username is "admin", the default multimedia port number is "6066" and the default command port is "6060".

After having detected the IP camera, right-click and select "Open in IE" to open a Web page on IE. See the applicable section in the complete manual if installation of an ActiveX component is required. You can select user name (default: admin), password (default: admin), stream type (Main/Sub Stream) and language on the login page.

Select "Login" to open the LIVE page.

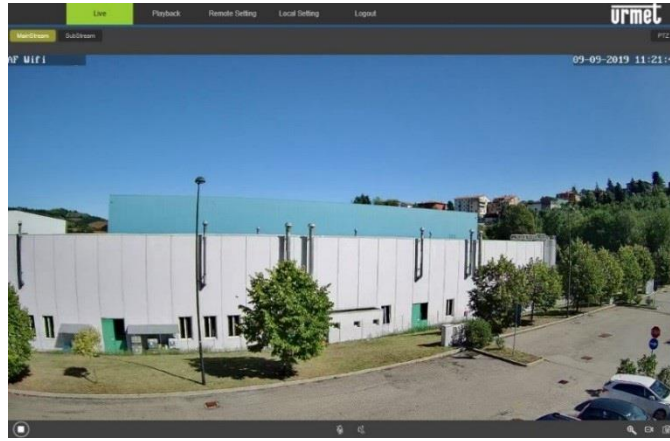

5 ACTIVEX CONTROL CONFIGURATION

You will need to install the plug-ins when inspecting the IP camera using Internet Explorer for the first time. Set the browse protection level to install the plug-in. Select the menu [Tools/Internet Options/Security/Custom Level] and for "ActiveX controls and plug-ins" select "Enable" or "Prompt", as shown in the following figure. For safety, reset the default protection setting in IE after having viewed the IP camera image.

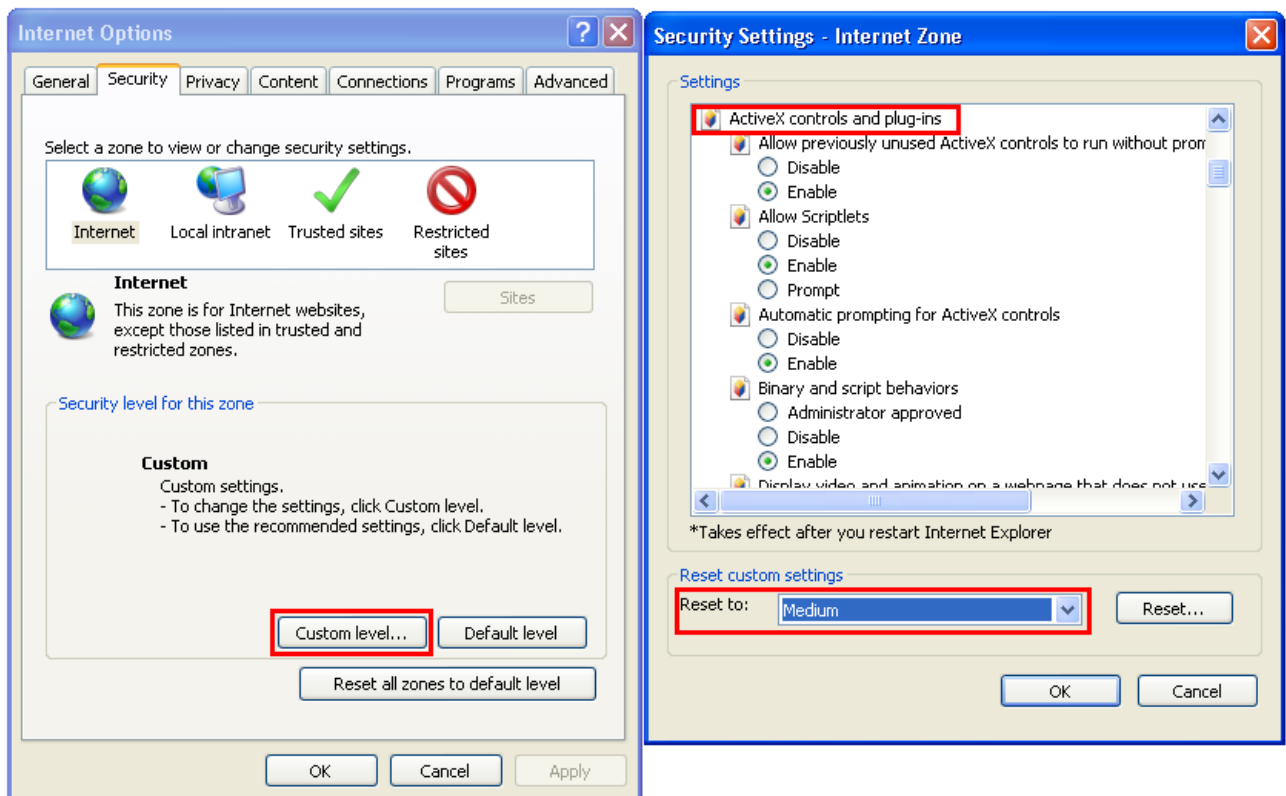

Plug-in installation method:

Enter the IP address of the IP camera on the IE address bar to inspect the IP camera. The controls will be loaded automatically on the IP camera.



The plug-in installation window will appear. Click on "Install" to complete the installation automatically.

6 CONNECTION FROM OTHER WEB BROWSERS

The camera web page can be accessed using a browser other than Internet Explorer, simply by keying in the IP address of the camera on the navigation bar of the browser.

In this case, no additional components need to be installed and the displayed stream live consists in MJPEG video stream for which selecting Main/Sub is not effective on the login home page.

IMPORTANT NOTE:

all the controls present on the lower bar of the live video (after login):



are available only if the Internet Explorer is used as browser after installing the ActiveX control of the camera on the PC. These controls are not available when connecting to the web page of the camera using different browsers from IE.

7 IP CAMERA WEB PAGE CONFIGURATION

7.1 LIVE

Open Internet Explorer or other browser and enter the IP address of the IP camera (e.g.: http://192.168.100.101). The login window appears. Observe the following figure:

The user can select the Stream Type on the access interface (this selection is only effective for Internet Explorer). Enter User name (default: admin) and Password (default: admin), select Language and click on "Login" to access the Live interface, as shown in the following figure.

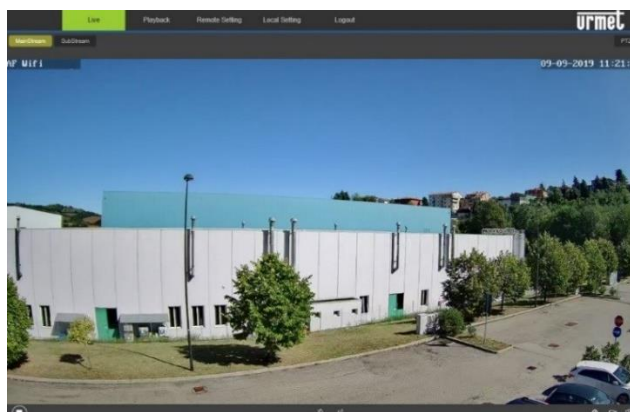

Right-click (on Internet Explorer with ActiveX only) to select the stream to be displayed (Main Stream, Sub Stream) and to view the bitrate.

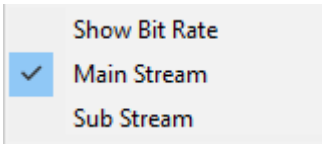

Other Live interface buttons (on Internet Explorer with ActiveX only):



: this is used to search and playback the video files recorded in the camera's SD memory card (not included).

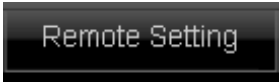

: This is used to access the device setup menu to set the various customised parameters;



: Snapshot, file type, saving path etc.;



: Close and go back to the login page;



: PTZ interface to control ZOOM and FOCUS (only for Autofocus camera models)





: Control button preview. From left to right, the buttons are: Start/Stop live video, Switch On/Off the PC Mic (to send audio to the camera), Switch On/Off the PC Audio (to receive audio from the camera), digital zoom, Start/Stop video recording on PC, Snapshot.

7.2 PLAYBACK

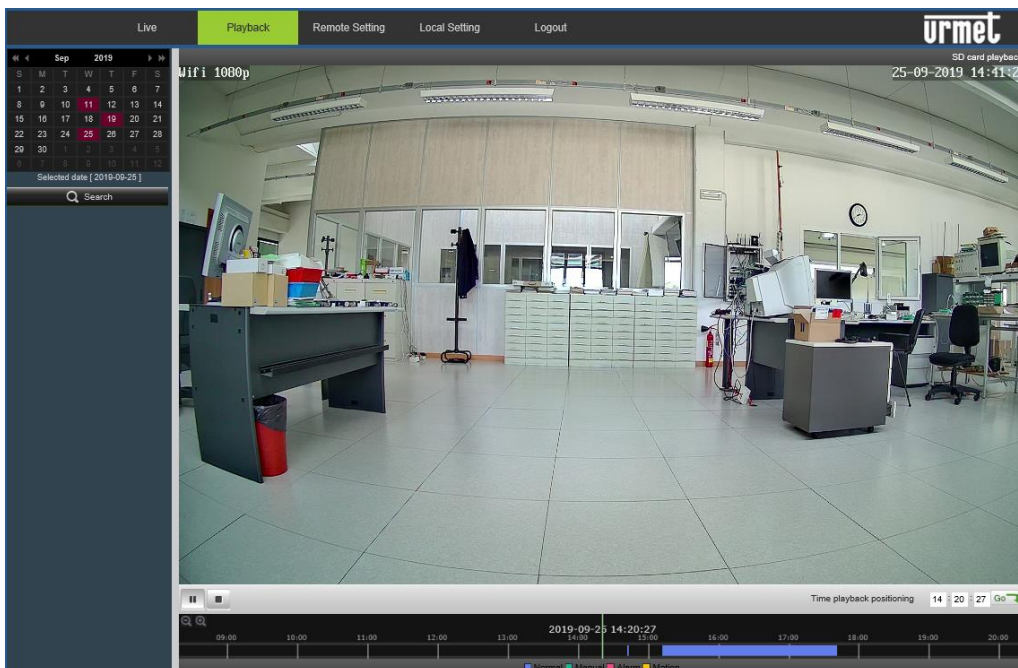

Click on to access the Playback interface:



Select one of the red dates within the selected month and push the button  to display the video recorded files on the time bar. Different colors refer to different recording Type (Normal, Manual, Alarm, Motion).

Use the button  to start playing back the video.

To quickly position the playback time cursor on the time bar during the playback you can use the function:



and push **Go** while the video is playing.

7.3 REMOTE SETTINGS

7.3.1 DISPLAY

1) OSD CONFIG

Click on  (Remote settings) to access the Live interface OSD Config (default).

- **Name:** IP camera name.
- **Channel Display:** Enable/Disable. The display position can be customised.
- **Time Display:** Enable/Disable. The display position can be customised.
- **Flicker Control:** 50Hz/60Hz/Close

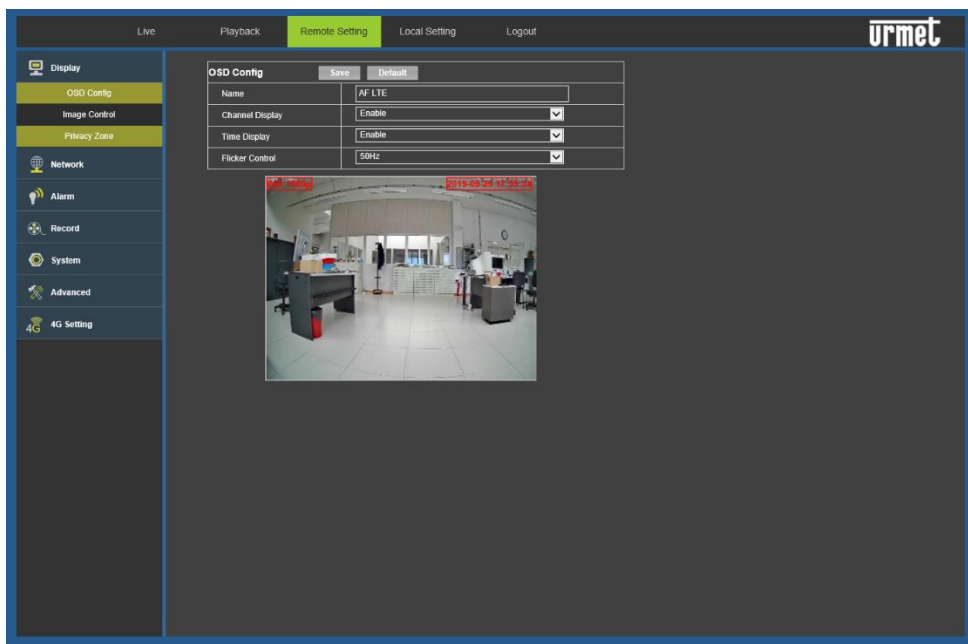

2) IMAGE CONTROL

Click on **【Display】** → **【Image Control】** to access the following interface.

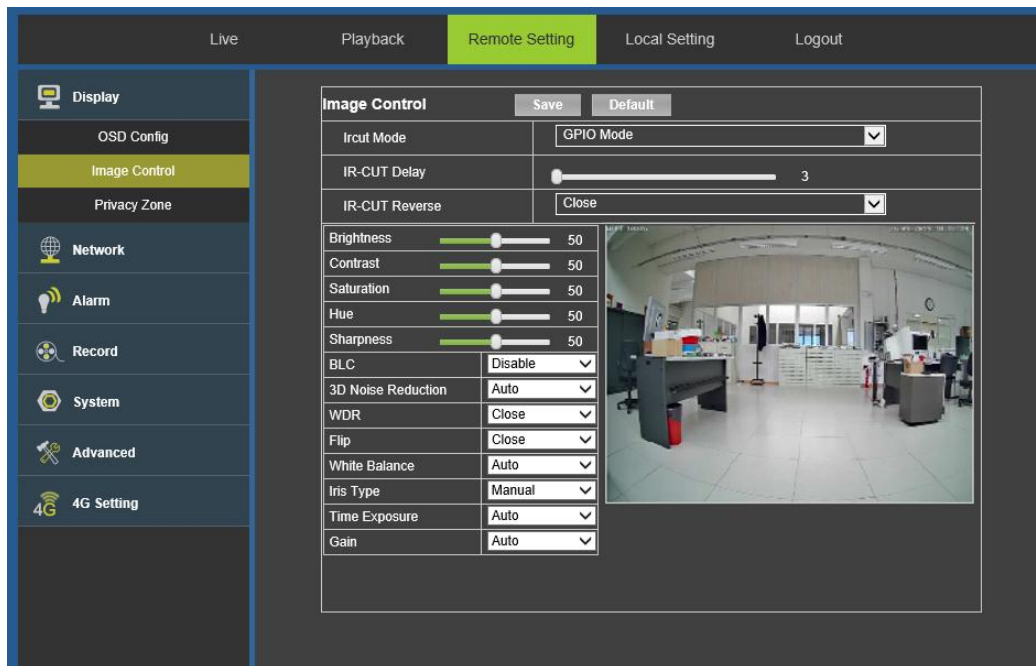

- **IR-CUT Mode:** 5 modes:
 - GPIO Mode or Passive Mode : default mode. The camera switches from colors to black and white (turning on the IR LEDs) and vice versa based on the environment light detected by the external sensor integrated in the camera.
 - Color Mode or Daytime: fixed setting as colors only, it never switches to B/W picture.
 - Black & White Mode or Night: fixed setting as B/W only, it never switches to color picture.
 - Video Mode or Active Mode: the camera switches from colors to black and white (turning on the IR LEDs) and vice versa based on the brightness level detected by the video sensor.
 - Time Mode or Timing: the camera switches from colors to black and white (turning on the IR LEDs) and vice versa based on the set time schedule
- **IR-CUT Delay:** This is the IRcut delay time.
- **IR-CUT Reverse:** Enable/Disable the inversion of the functionality
- **Image setting:** This is used to adjust brightness, contrast, saturation, hue, sharpness.
- **BLC (Back light compensation):** This is used to Enable/Disable backlight compensation. This function can compensate the shadows on the subject in case of exposure against sunlight. In some scenarios of use, the visual field may contain a very bright background, such as a door or a window in full sunlight, with the observed subject surrounded by the light field. In this case, the picture may appear dark and flat. Backlighting compensation may be used to solve this problem.
- **3D Noise Reduction:** Auto/Weak/Normal/Strong
- **WDR:** This enables or disables the WDR function: Weak, Normal, Strong. WDR allows the camera to acquire highly contrasted images. In short, DR (dynamic range) shows the details of the light part and the dark part of the image. A broader dynamic range shows richer layers and a vaster colour range.
- **Flip:** 4 modes: Close, Leftright, Updown, Center.
- **White Balance:** Auto, Manual, Incandescent, Warm, Fluorescent, Natural.
 - Manual:** Manual gain adjustment of red and blue colours for the camera video.
 - Auto:** Optimisation according to the current lighting conditions and method of the screen and video colour calibration of the camera video colours.
- **Iris Type:** Manual and automatic modes can be selected. The default mode is Auto.
- **Time exposure:** Camera exposure level adjustment.
- **Gain:** Automatic gain level AGC adjustment (Auto, 6dB, 12dB, 18dB, 24dB, 30dB, 36dB, 42dB).

3) PRIVACY ZONE

Click on **【Display】** → **【Privacy Zone】** to access the following interface.

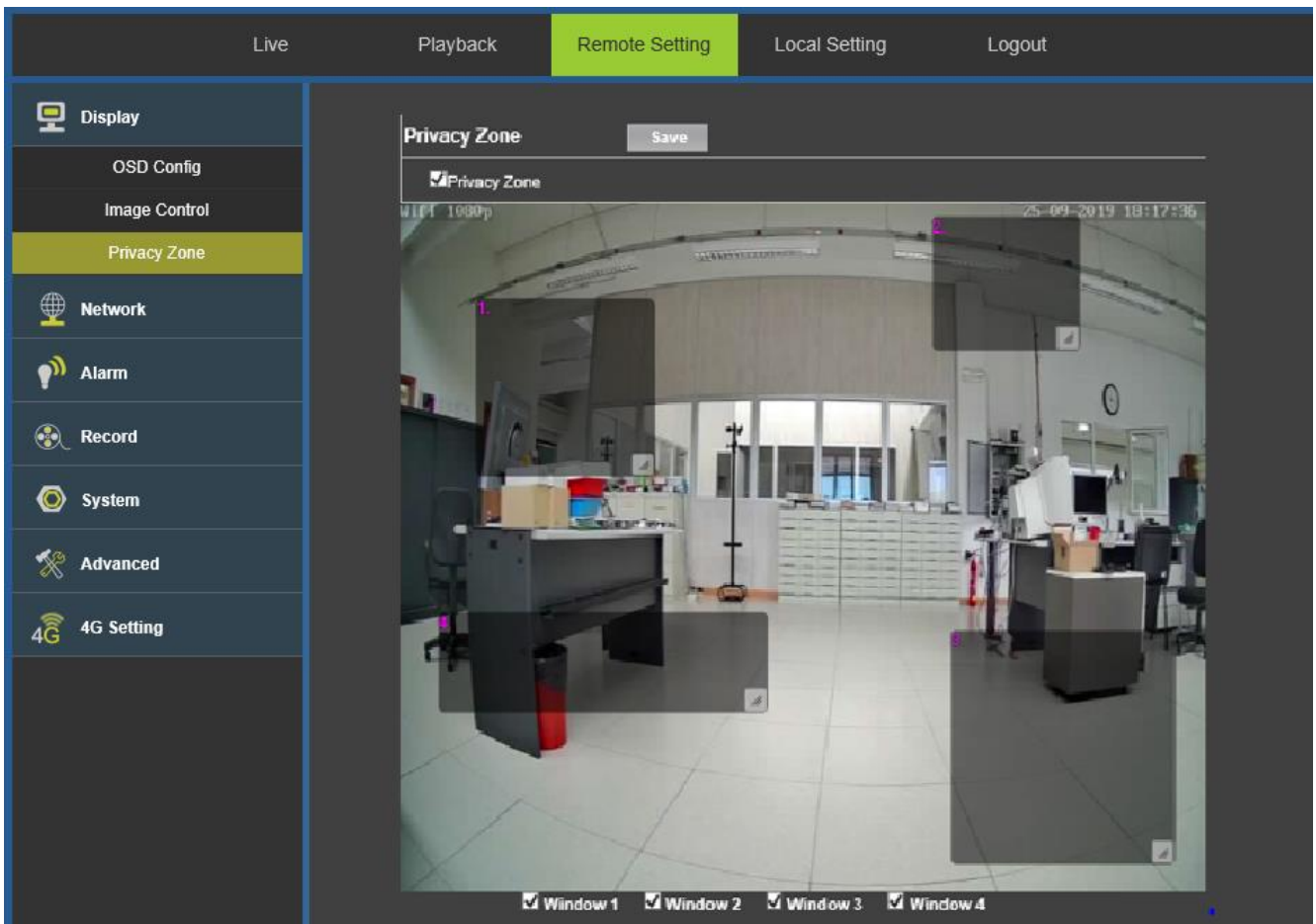

Privacy zone setting:

1. Click to enable the privacy zone.
2. Select the Privacy area to be activated from the available four (Window 1, Window 2, Window 3, Window 4).
3. Point to the corner in the bottom right of each Privacy area and drag the mouse to change the size. Then position the Privacy area on the concerned area of the image.
4. Click on Save to activate the privacy area.

7.3.2 NETWORK

1) Network configuration

Click on **【Network】** → **【Network Setting】** to access the following network page.

Live Playback **Remote Setting** Local Setting Logout

Display

Network

Network Setting

Video Streaming

FTP

Email

RTSP

P2P

Alarm

Record

System

Advanced

4G Setting

Network Setting		Save	Default
Type	DHCP		
Command Port	6060		
HTTP Port	80		
IP Address	192.168.100.101		
Subnet Mask	255.255.255.0		
Gateway	192.168.100.1		
DNS 1	192.168.100.1		
DNS 2	192.168.1.1		
Media Port	6066		
MAC Address	5A:58:5B:8B:8F:C7		

This page can be used to display and set the parameters related to the LAN of the camera:

- **Type:** DHCP, Static or PPOE. The default setting is Static.
- **Command Port:** This is the command port of the IP camera. Default: 6060
- **HTTP Port:** This is the web port of the IP camera. Default: 80
- **IP address:** Camera IP address
- **Subnet Mask:** Subnet mask of the IP camera.
- **Gateway:** IP address of the gateway used to access the Internet
- **DNS1/DNS2:** IP addresses of the DNS servers.
- **Media Port:** This is the client port of the IP camera. Default: 6066
- **MAC address:** This is the MAC address of the LAN board of the camera.

Only in the case that the camera has to be recorded by a network device HVR/NVR, it is advisable to set a static IP address after having appropriately connected and configured the camera in the network. Make sure that the IP address you want to assign to the camera is not already used in the network. It is better to use an address outside the range of addresses assigned by means of DHCP.

Select "**Type = Static**" and fill in the following fields: IP address, Subnet mask, Gateway and DNS. Press **Save** to save the changes.

2) Video Stream

Click on **【Network】** → **【Video Streaming】** to access the following interface.

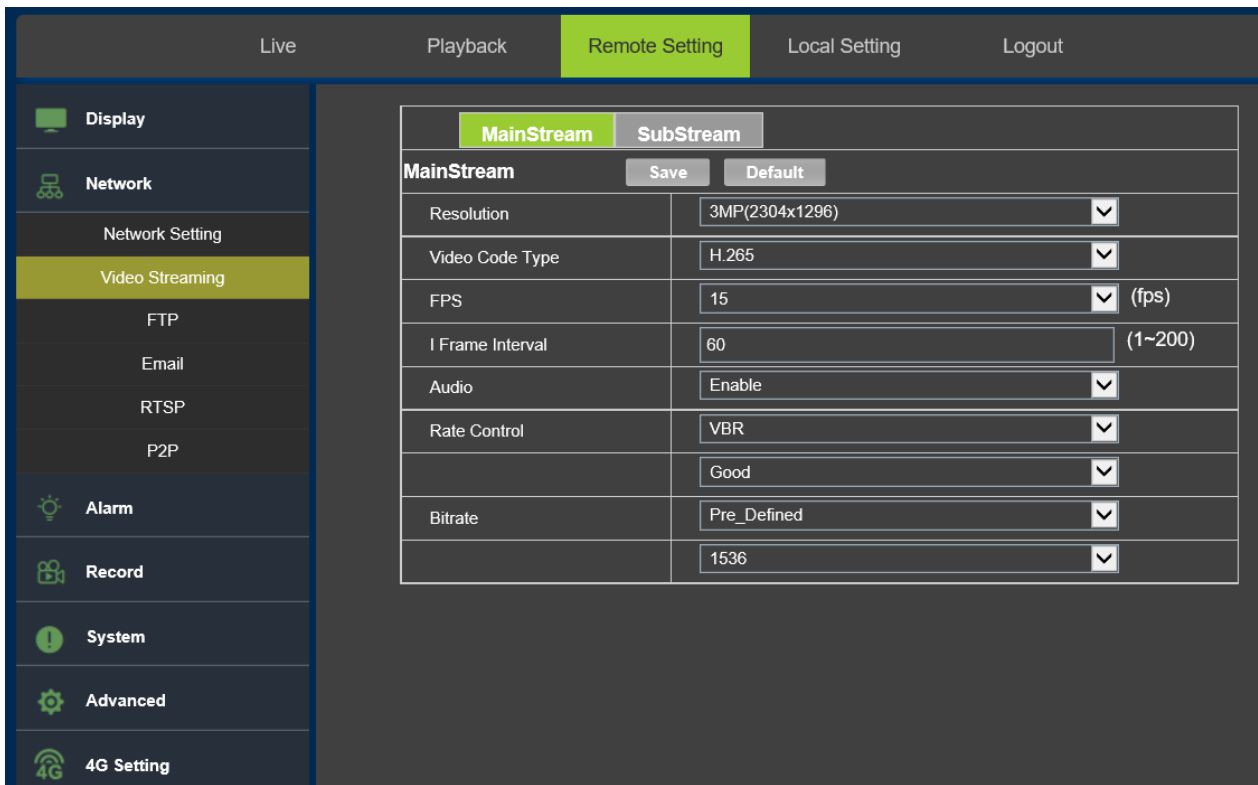

- **Type:** MainStream, SubStream.
- The user can set: Resolution, FPS, Audio (if the camera model has audio input), Bitrate control: CBR/VBR and the MainStream/SubStream Bitrate value.
- **Resolution:** MainStream MainStream 3MP (2304x1296), 1080P(1920x1080), 720P (1280x720), SubStream (704x576, 640x360).
- **FPS:** max 20 for the Mainstream and 25 for the Substream.
- **I Frame Interval:** set the I frame interval between 1 and 200.
- **Audio:** enable/disable TLC audio input (if supported by the camera model).
- **Rate Control:** Set the Bitrate management as CBR (Constant Bit Rate) or VBR (Variable Bit Rate, at 6 quality levels from Best to Worst).
- **Bitrate:** set the transmission speed to bits per second as manual (user-defined) or default value.

※IMPORTANT NOTE:

It is possible to access the third stream of the camera which is a MJPEG stream, by inputting the following URL in any internet browser's navigation bar:

<http://IP/Streams/1/4/ReceiveData>

Description:

- IP: to be replaced with the actual IP address of the device
- The MJPEG stream resolution can be modified in the following section: **【Advanced】** → **【Snapshot Settings】**

※IMPORTANT NOTE:

The HTTP URL to get single JPEG snapshots is the following:

<http://IP/Snapshot/1/RemotelImageCapture?ImageFormat=2>

Description:

- IP: to be replaced with the actual IP address of the device
- The JPEG snapshot resolution can be modified in the following section: **【Advanced】** → **【Snapshot Settings】**

3) FTP

Click on **【Network】**) → **【Email】** to access the following interface.

The screenshot shows a web management interface with a top navigation bar containing 'Live', 'Playback', 'Remote Setting' (highlighted), 'Local Setting', and 'Logout'. A left sidebar lists various settings: Display, Network (selected), Network Setting, Video Streaming, FTP (highlighted), Email, RTSP, P2P, Alarm, Record, System, Advanced, and 4G Setting. The main content area is titled 'FTP' and includes 'Save' and 'Default' buttons. The configuration table is as follows:

FTP	
FTP	Enable
Server	
Port	21
User name	username
Password
Passive mode	Disable
Save directory path	ftp
Uploading	Picture
Status	not connect Test FTP

For some FTP server, before using this function, it is necessary to create a folder named 'ftp' in the root directory of the server!

Server: it supports IP address or domain string

4) Email

Click on **【Network】**) → **【Email】** to access the following interface

The screenshot shows a web management interface with a top navigation bar containing 'Live', 'Playback', 'Remote Setting' (highlighted), 'Local Setting', and 'Logout'. A left sidebar lists various settings: Display, Network, Network Setting, Video Streaming, FTP, Email (highlighted), RTSP, P2P, Alarm, Record, System, Advanced, and 4G Setting. The main content area is titled 'Email' and includes 'Save' and 'Default' buttons. The configuration table is as follows:

Email	
Email	Enable
Encryption	Disable
Authentication	Enable
SMTP Port	25
SMTP Server	
Sender Email	
Sender Pwd
Receiver Email1	
Receiver Email2	
Receiver Email3	
Subject	
Content	
Snap Interval	1min

Test Email

Email service setting. By using this function in association with the Motion alarm function, the camera can sent the images acquired by email on the Internet by contacting the set email server (SMTP).

Email: Disable/Enable.	SMTP Port: The default value is 25 (email service port). If SSL is enabled, the port is usually 465.
SSL: Disable/Enable.	Authentication: Disable/Enable.
SMTP Server: Enter the email server address.	Sender Email: The sender's email address.
Sender Pwd: The sender's email password.	Receiver Email: The recipient's email address (three addresses are possible).
Snap Interval: This is the email sending frequency in case of event.	Test Email: This sends a email to test that parameter are correct.

5) RTSP

Click on **【Network】**) → **【RTSP】** to access the following interface.

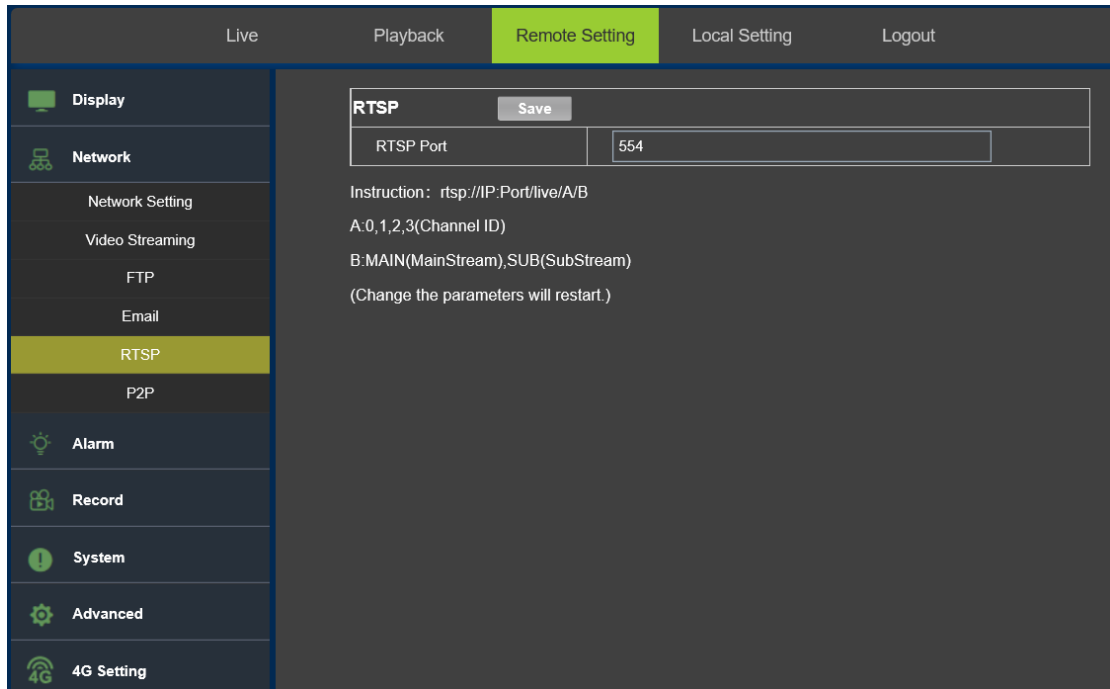

- **RTSP Port:** The default password is 554. The device will be restarted after the change.

Description

- rtsp://IP:Port/live/A/B
- IP: IP address of the device.
- Port: RTSP port of the device. Default: 554.
- A: 0, 1, 2 ... channel ID number (for camera type devices use any ID, e.g. 0).
- B: MAIN refers to “main stream”, SUB refers to “sub stream”.

6) P2P

Click on **【Network】**) → **【P2P】** to access the following page.

P2P refers to the functionality that makes the device available for connections from remote software and app through the Internet, without any port-forwarding/virtual server setting in the router.

Live Playback **Remote Setting** Local Setting Logout

Display

Network

Network Setting

Video Streaming

FTP

Email

RTSP

P2P

Alarm

Record

System

Advanced

4G Setting

P2P Save

P2P	Enable
UUID	IOTBDD-928754-TKGUT,RUGJUY#D
	
Status	offline

Description

- **P2P**: enable/disable the function. Default: enabled
- **UUID**: this is the ID code that identifies univocally the devices and that has to be input in the software/app to open the connection to the camera. It is also available on the device as a QR code label.
- **Status**: "internet ready" means that the device can connect to the internet through the router, so it is available to accept connections from software/app installed on remote PC/smartphone.

7.3.3 ALARM

1) AI SETTING

Click on **【Alarm】** → **【AI Setting】** to access the following interface.

Setting Procedure

1. Enable/disable person detection (Human) and/or motion detection (Motion).
2. While holding down the left button, drag the mouse to select the person and/or motion detection area. It is also possible to choose polygonal-shaped areas (triangle, pentagon, hexagon, etc.) as shown opposite the image. It is also possible to enable individual cells by clicking on them.
3. Set the sensitivity of person and/or motion detection
4. Following a Human and/or Motion event, the following actions can be activated:
 - **Send e-mail:** send e-mail (with image attached to the e-mail)
 - **Send to FTP:** Save image to FTP server (to set FTP server see section **【Network】** → **【FTP】**)
 - **Push Notification:** Sending push notification to V-Stream app on smartphone (Attention you need to activate the notification reception also in the ALARMS menu of V-Stream app)
 - **Video on SD:** recording on local microSD memory (not included).
 - **Snapshot on SD:** image saved on camera-mounted microSD memory.
 - **Sound Alarm:** Activation of sound alarm on camera.
5. Click on **Save** to make the setting active.

2) SCHEDULE

Click on **【Alarm】** → **【Schedule】** to access the following interface.

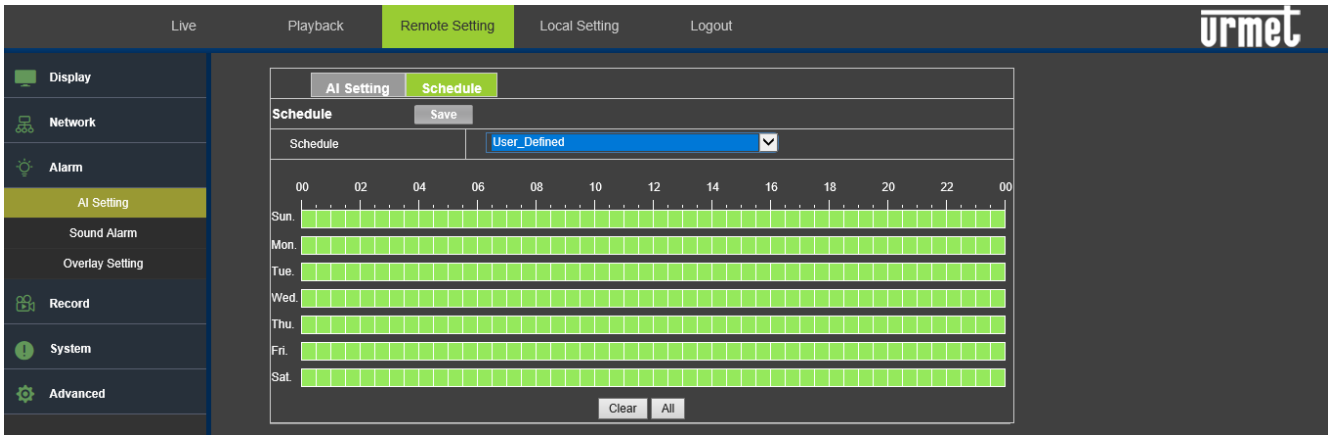

Schedule: in this page it is possible to program when the alarm must be activated (All Day, User_defined). When **【User_defined】** is selected, holding the left button pressed, drag the mouse to select the programming periods. Single cells can be enabled by clicking on each of them. By clicking on each weekday's name, the whole day line is enabled/disabled.

Press **Save** to save the changes.

3) SOUND ALARM

Click on **【Alarm】** → **【Sound Alarm】** to access the following interface.

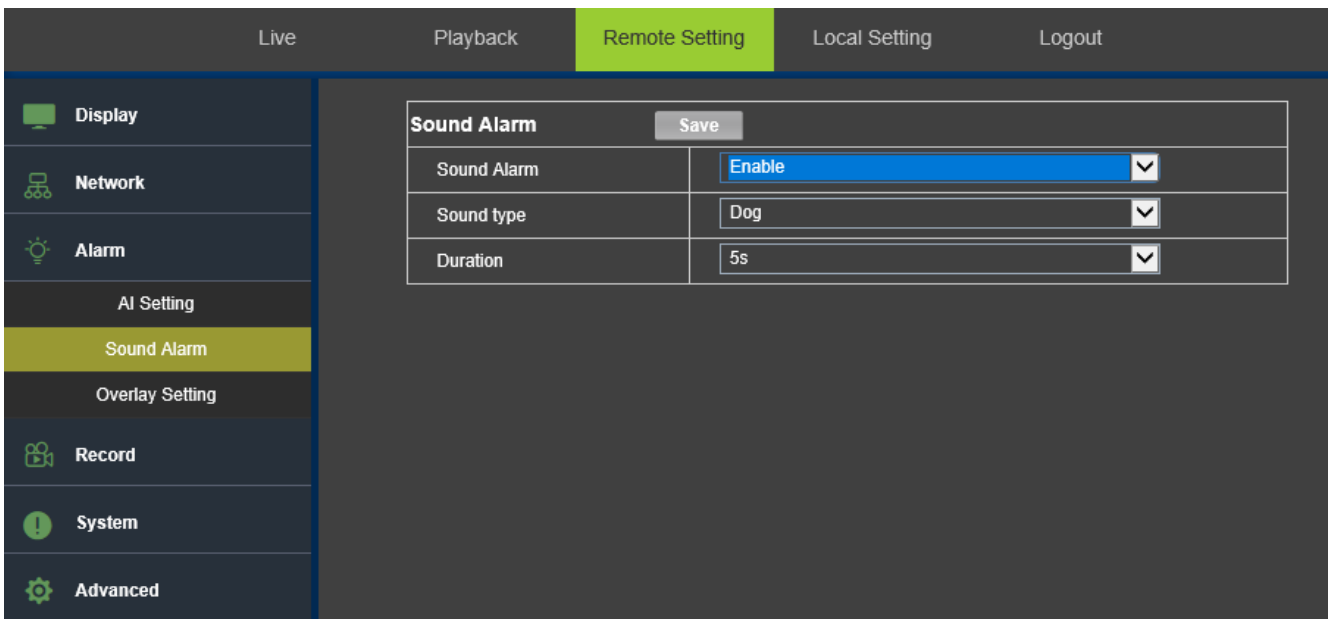

Setting procedure:

1. Enable or disable the camera's Sound Alarm
2. **Sound Type:** Choose the sound type for the sound alarm from Siren, Dog and Set on App.
3. **Duration:** Set the duration of the sound alarm. You can choose between 5s, 10s, 20s and 30s.

Press **Save** to save the changes.

4) OVERLAY SETTING

Click on **【Alarm】** → **【Overlay Setting】** to access the following interface.

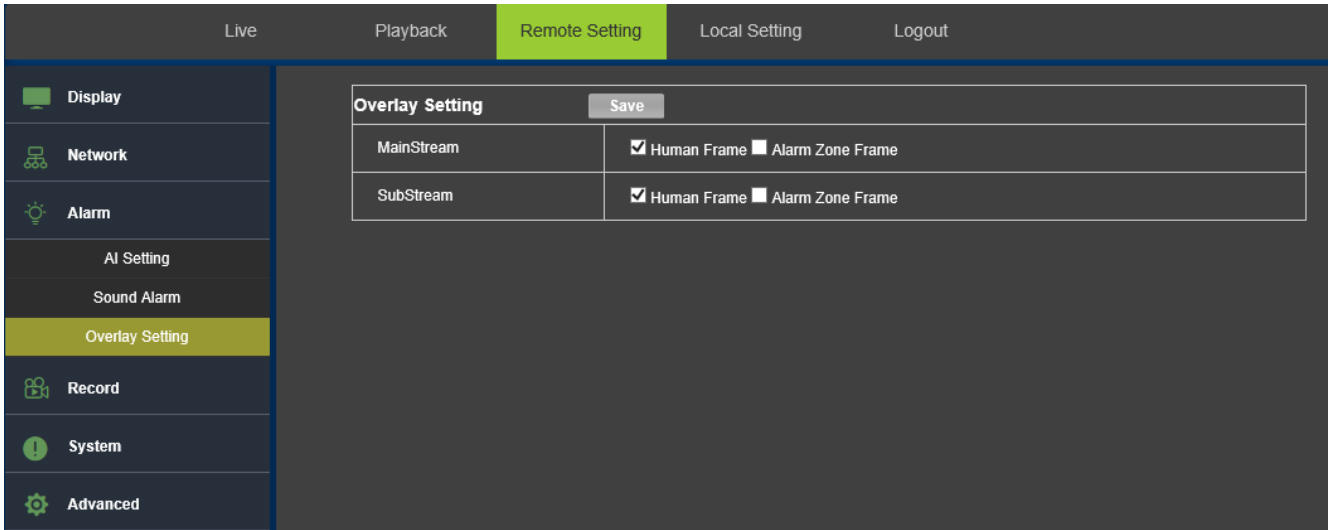

Main Stream: if the boxes are ticked, this enables the display of video analysis lines on identified persons and/or areas enabled on the main video stream (Main Stream).

Sub Stream: if the boxes are ticked, it enables the display of video analysis lines on identified persons and/or enabled areas on the secondary video stream (Sub Stream).

Press **Save** to save changes.

7.3.4 RECORD

Click on **【Record】** → **【Schedule】** to access the following page.

In this page it is possible to set the weekly schedule of video recording function on the SD memory card.

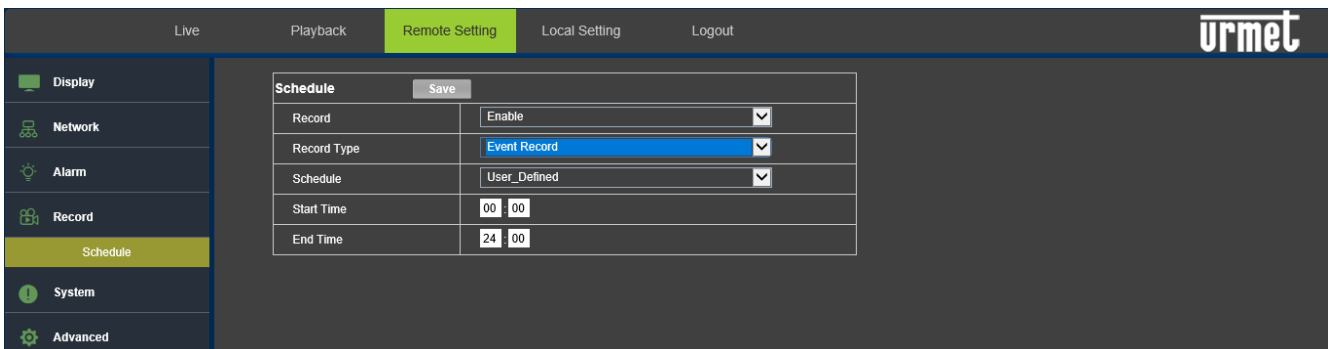

Record: video recording can be enabled.

Record Type: You can choose between Event Record or Continuous Record.

Schedule: It is also possible to schedule the type of recording by choosing between Only Daytime, One Day, User Defined and the time slots in which the recording is to be active.

Start Time: You define the start time of the recording.

End Time: You define the end time of the recording.

Press **Save** to save the changes

※IMPORTANT NOTE:

It is possible to activate manually the recording of a single file using the http command:

http://IP/Record/HttpEvent/Call

Description:

- IP: to be replaced with the actual IP address of the device

The Manual recording is executed also if the Record Schedule is “No Record”.

※IMPORTANT NOTE:

No matter the record type (Normal, Motion, Manual) each footage is finalized and saved to the memory once the file has attained the size of around 7MB.

7.3.5 SYSTEM

The System menu contains the following items: 【Date/Time】 , 【Users】 , 【Info】 and 【Log】 . The respective interfaces and descriptions are shown below.

1) DATE/TIME SETTING

Click on 【System】 → 【Date/Time】 to access the following interface.

PARAMETERS: the Device Name can be changed here.

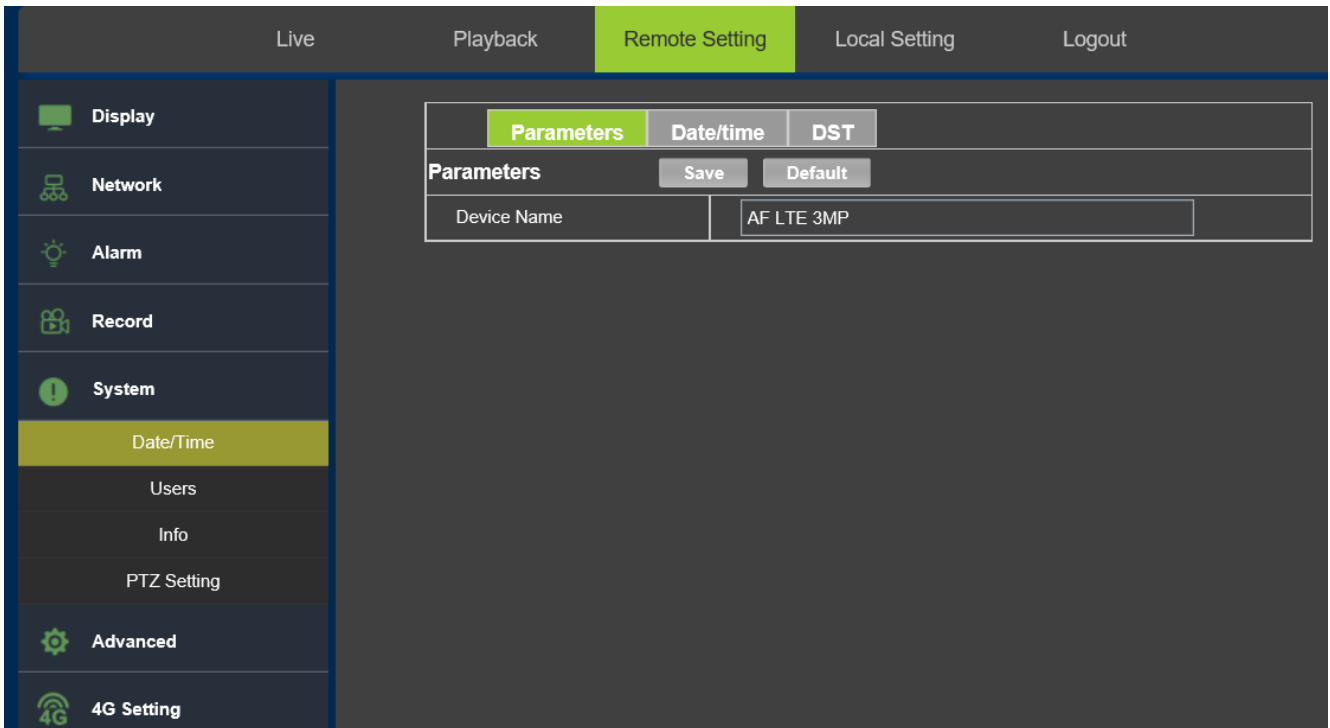

DATE/TIME: this user interface can be used to set the date and time, including System Time, NTP, Date Format and Time Format. After having made the setting, click on Save.

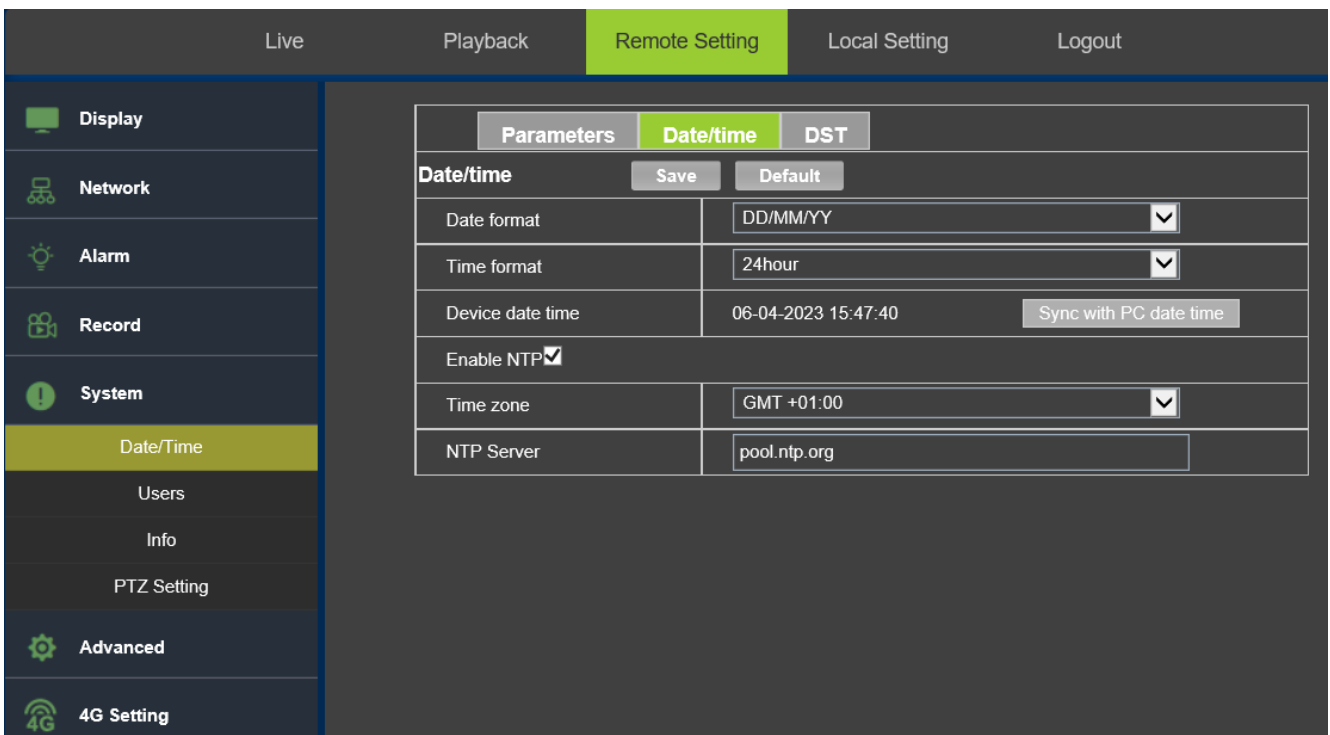

The device sets to the automatic time synchronisation function:

- **NTP:** Synchronise time with the NTP server on the Internet. Click on NTP to enable the NTP setting. Enter the NTP server address, select the time zone and click on Save. The system will automatically synchronise the time with the NTP server.
- **Synchronize with computer time:** this assigns the date/time indicated on the personal computer to the device.

DST: enable/disable the DST (daylight saving time) function. The device set the time according to the Time Offset and the set period of year.

The screenshot shows the 'Remote Setting' tab in a web interface. The left sidebar contains menu items: Display, Network, Alarm, Record, System, Date/Time (highlighted), Users, Info, PTZ Setting, Advanced, and 4G Setting. The main content area has sub-tabs: Parameters, Date/time, and DST (highlighted). Under the DST sub-tab, there are 'Save' and 'Default' buttons. The configuration includes:

- Enable DST:
- Daylight Saving Time Mode: Week (dropdown)
- Time Offset: 1Hour (dropdown)
- Start Time: Mar. (dropdown), The last (dropdown), Sun. (dropdown), 02 : 00 : 00
- End Time: Oct. (dropdown), The last (dropdown), Sun. (dropdown), 03 : 00 : 00

2) USERS

Click on **【System】** → **【Users】** to access the following interface.

The screenshot shows the 'Users' management interface. The left sidebar is the same as in the previous screenshot, with 'Users' highlighted. The main content area has a 'Save' button and a table of users. To the right of the table are input fields for 'User Name', 'Pass Word', and 'Active'.

NO.	User Name	Active
1	admin	Enable
2	user1	Disable
3	user2	Disable
4	user3	Disable
5	user4	Disable
6	user5	Disable

Form fields on the right:

- User Name: admin
- Pass Word: [Empty]
- Active: Enable (dropdown)

New users can be created, activated and deactivated and the password can managed here.

3) INFO

Click on **【System】** → **【Info】** to access the following interface.

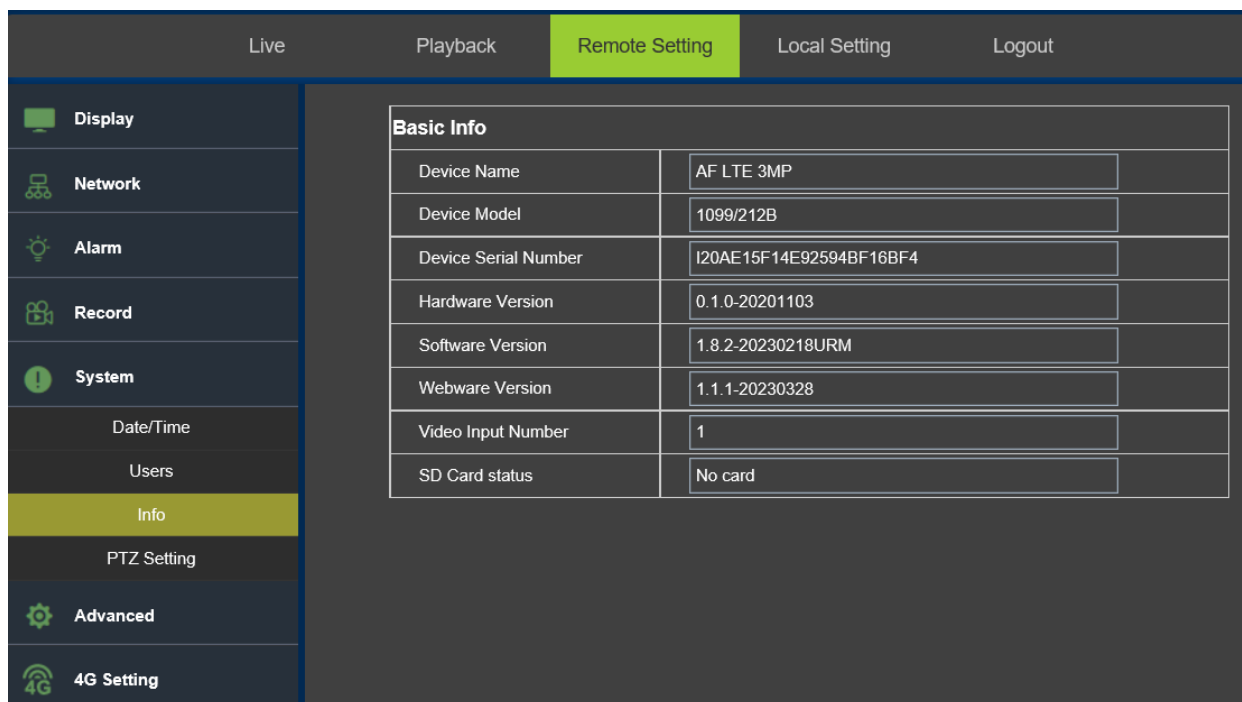

When an SD memory card is plugged into the camera's slot, it is possible:

- To read the information about total and available memory space
- To format the memory card by pushing the button **Format SD Card as fat32**
- To browse the memory card's content by pushing the button **Browser SD Card**. This operation leads to the camera's page:

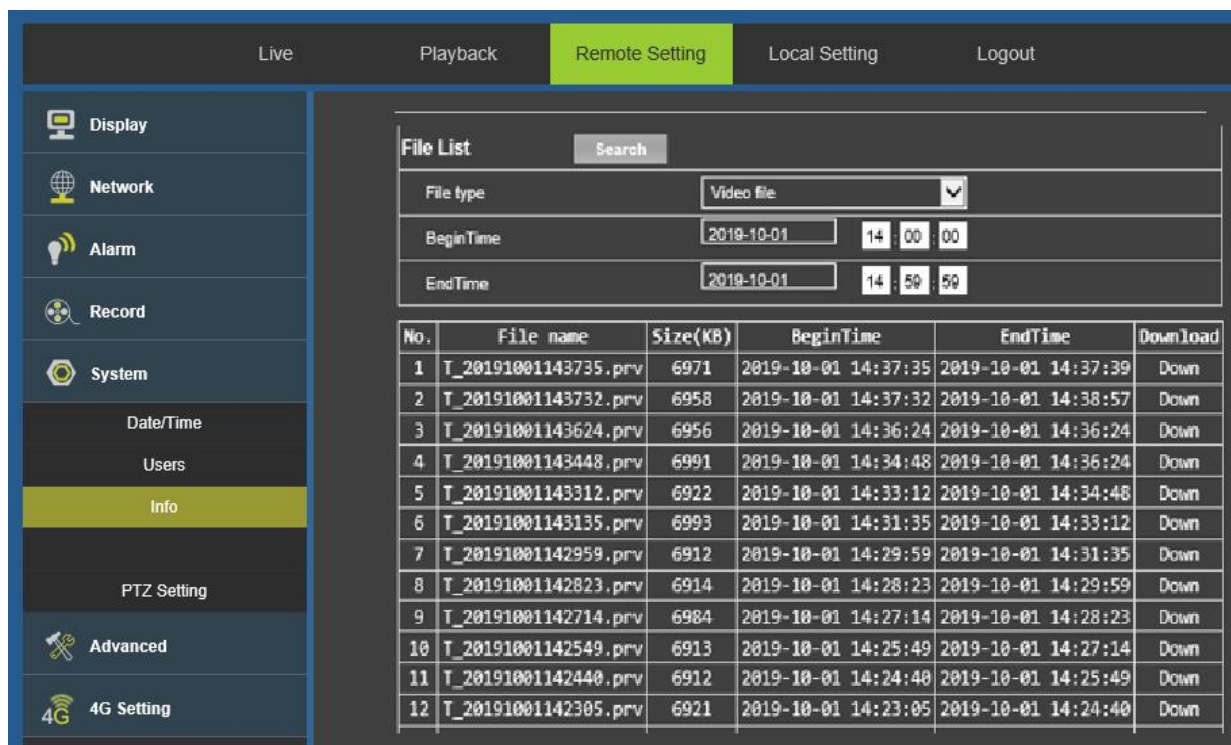

Select **File Type** -> **【Video file】** to list video recordings or **File Type** -> **【Image File】** to list the snapshots, then select Begin Time and End Time to set the time interval, then press the button **Search** to execute the search files (**M** at the beginning of the file's name stands for Motion Event video, **T** at the beginning of the file's name stands for Normal Schedule video, **H** at the beginning of the file's name stands for Manually Recorded video through http command):

4) **PTZ**
Control of the Zoom management parameters of the camera

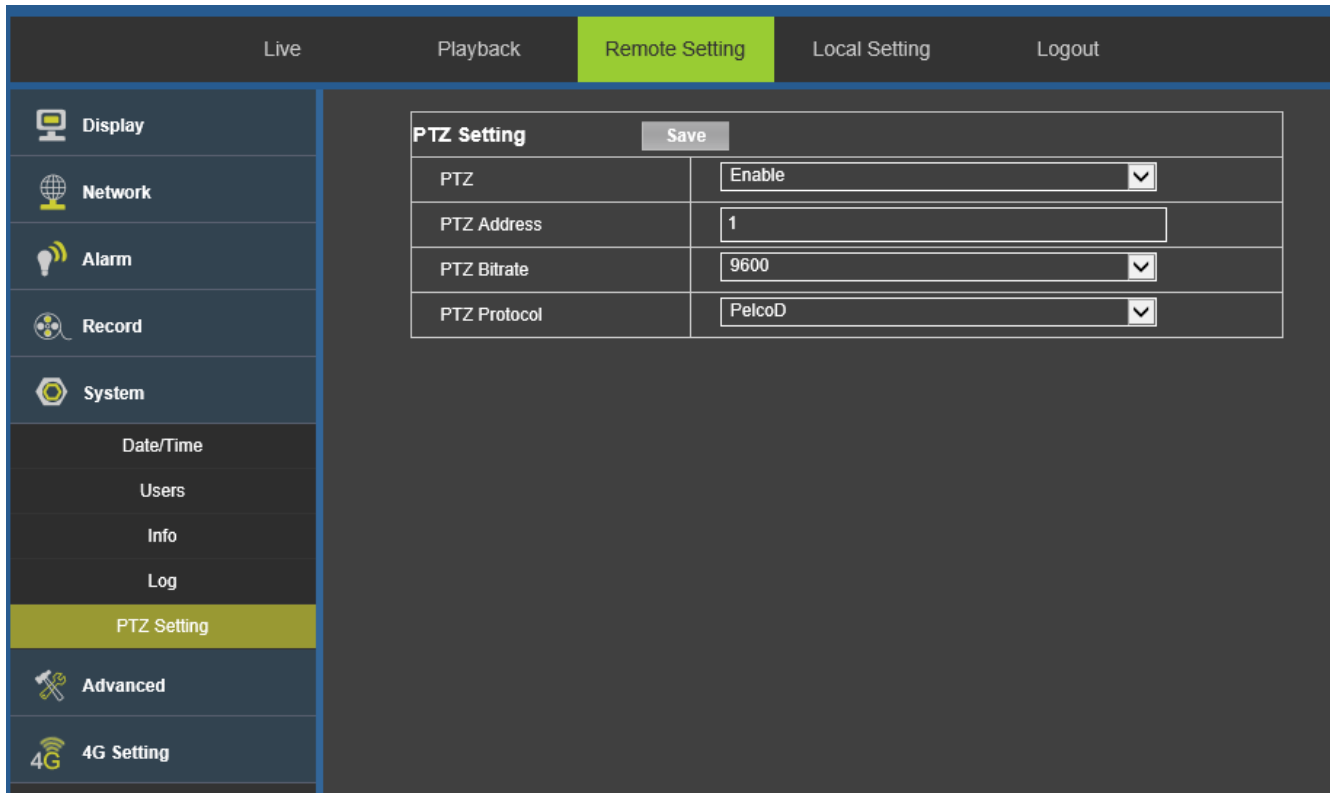

7.3.6 **ADVANCED**

The options **【Audio Setting】** , **【Time Capture】** , **【Firmware Update】** , **【Load Default】** and **【Maintain】** are present as shown in the following figure:

1) **Audio Setting**

Microphone and audio input sound settings.

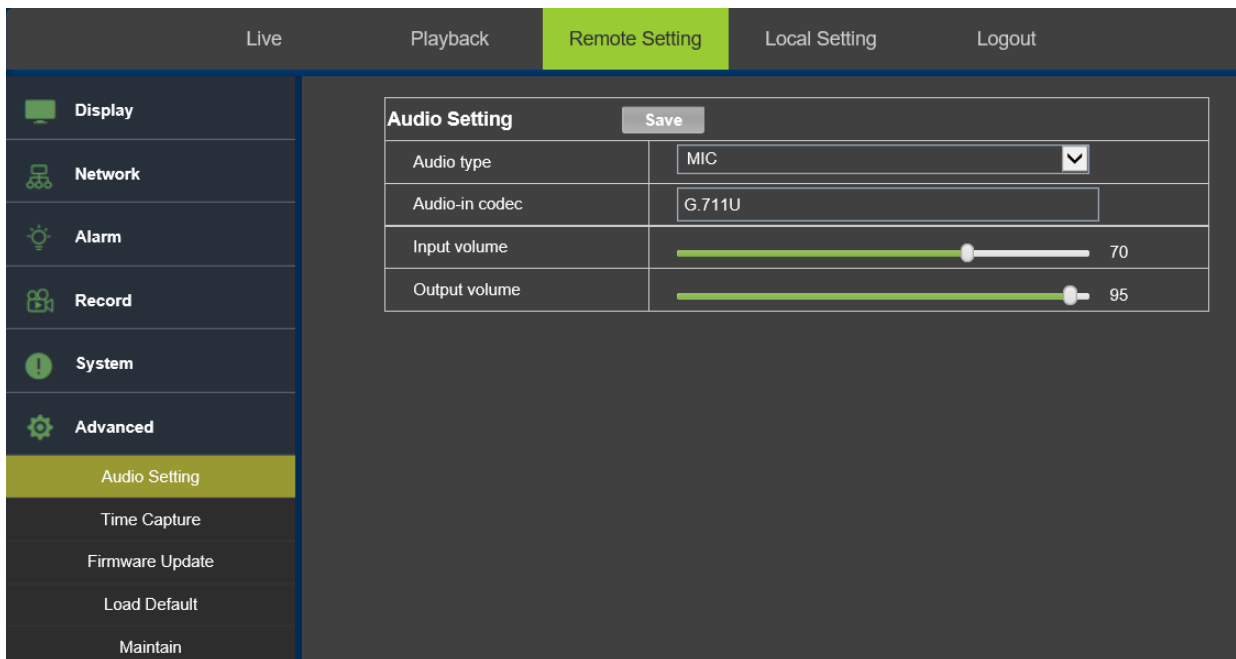

- **Audio Type:** you can choose the type of audio.
- **Audio Codec:** The managed audio codec is the G711U.
- **Input Volume:** Set the input audio volume.
- **Output volume:** Set the output audio volume.

Press **Save** to save changes.

2) Time Capture

The following settings refer to periodic saving of images on local micro SD memory or FTP server.

Time Capture		Save
Save images to SD card	<input type="text" value="Disable"/>	▼
Save image to SD card interval	<input type="text" value="10"/>	(10~86400s)
Save images to FTP	<input type="text" value="Disable"/>	▼
Save image to FTP interval	<input type="text" value="10"/>	(10~86400s)

5) Firmware upgrade

Click on **Advanced** → **Firmware Update** to access the following interface.

The screenshot shows a web interface with a top navigation bar containing 'Live', 'Playback', 'Remote Setting' (highlighted), 'Local Setting', and 'Logout'. A left sidebar menu includes 'Display', 'Network', 'Alarm', 'Record', 'System', 'Advanced', 'SnapShot Setting', 'Time Capture', 'Firmware Update' (highlighted), 'Load Default', 'Maintain', and '4G Setting'. The main content area is titled 'Firmware Update' and contains a form with an 'Upgrade file path' input field, a 'Scan...' button, and an 'Upgrade' button.

In the "Firmware Update", the user can click on "Scan" to select the update file; click on Upgrade to update the system automatically. If the update file does not correspond to the device, the update will not be performed.

Note: The firmware update procedure will last approximately 5 minutes. Do not interrupt the power supply or disconnect from the network during the update.

6) Load Default

Click on **Advanced** → **Load Default** to access the following interface.

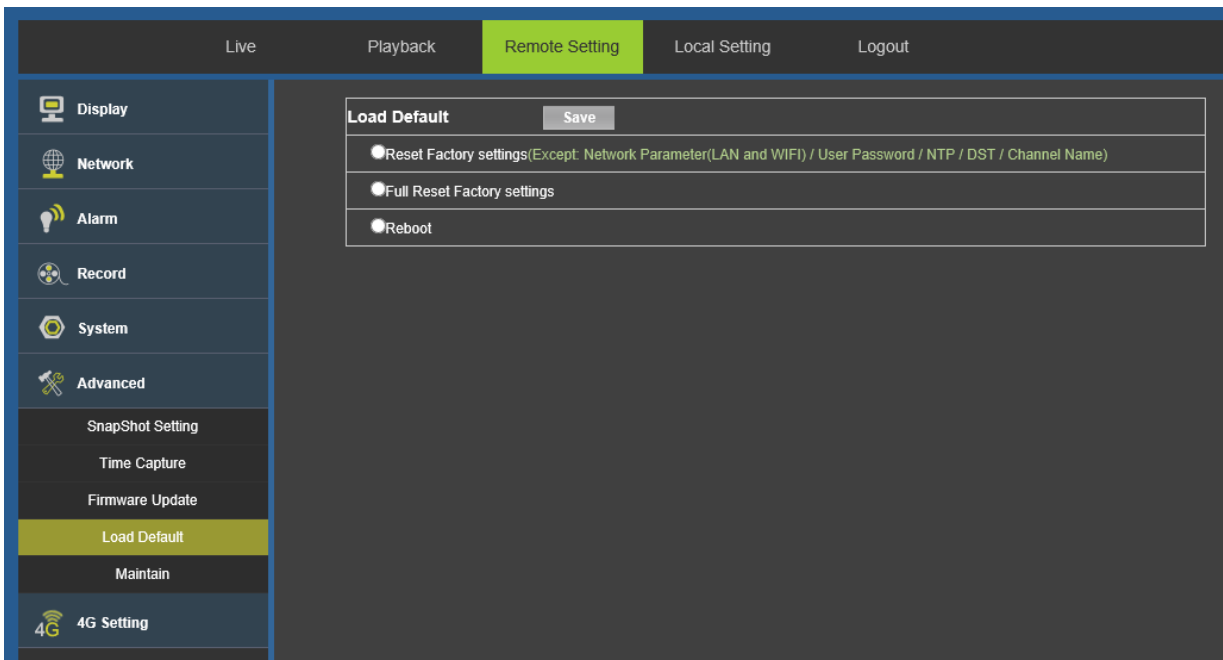

Select “**Reset factory settings**” and press the **Save** button to restore all default setting except for: network parameters (LAN and Wireless), user Password, NTP, DST, channel name.

Select “**Full Reset factory settings**” and press the button **Save** to restore the factory default settings.

Click on “**Reboot**” and press the button **Save** to restart the device.

7) Maintenance

Click on **【Advanced】** → **【Maintain】** to access the following interface.

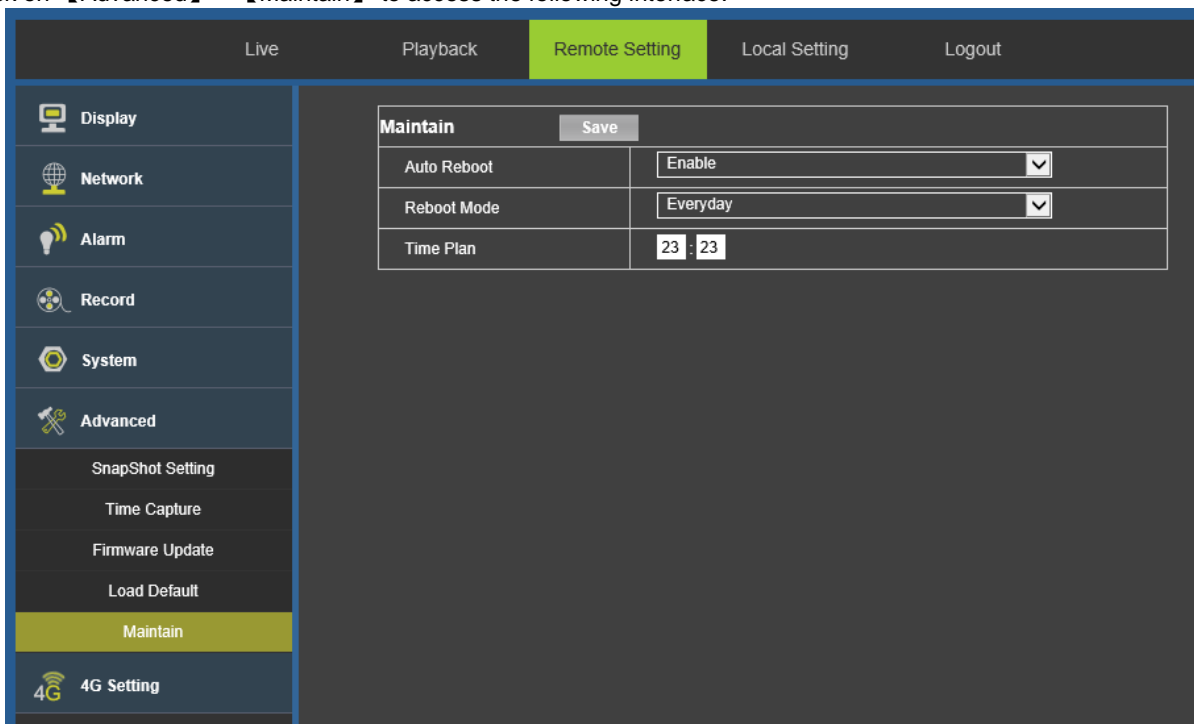

- **Auto Reboot:** enable/disable automatic restart of the device according to the indicated time programming.
- **Auto Reboot:** Select one of the three options Everyday, Everyweek, Once.
- **Week plan:** Select the days of the week on which to start automatic reboot.
- **Time plan:** Select the time on which to start automatic reboot.

IMPORTANT: the reboot might cause the loss of some minutes of recording.

IMPORTANT: if the camera is in a dark environment, it might take up to 20 seconds to restore the correct black and white picture (i.e. Night Mode) after the reboot.

7.3.7 4G SETTINGS

1) Direct

You are asked to open content in a new window. For details, refer to chapter 10.

2) Manual

Enter the value for the connection to the router 192.168.100.1.

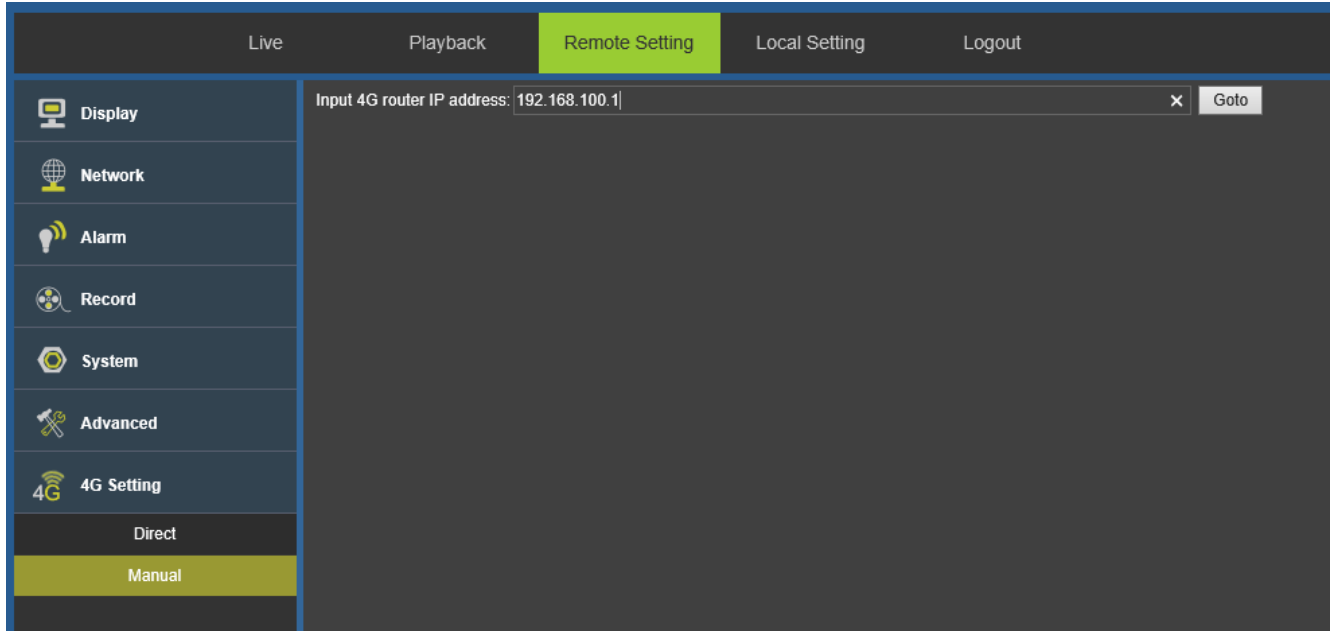

And you are asked to open the contents in a new window. For details, refer to chapter 10.

7.4 LOCAL SETTINGS

Click on “**Local Setting**” to view the following dialogue window.

The user can set Local Disk, Record Path, Snapshot path, file type and Interval for recording and manual snapshot capturing.

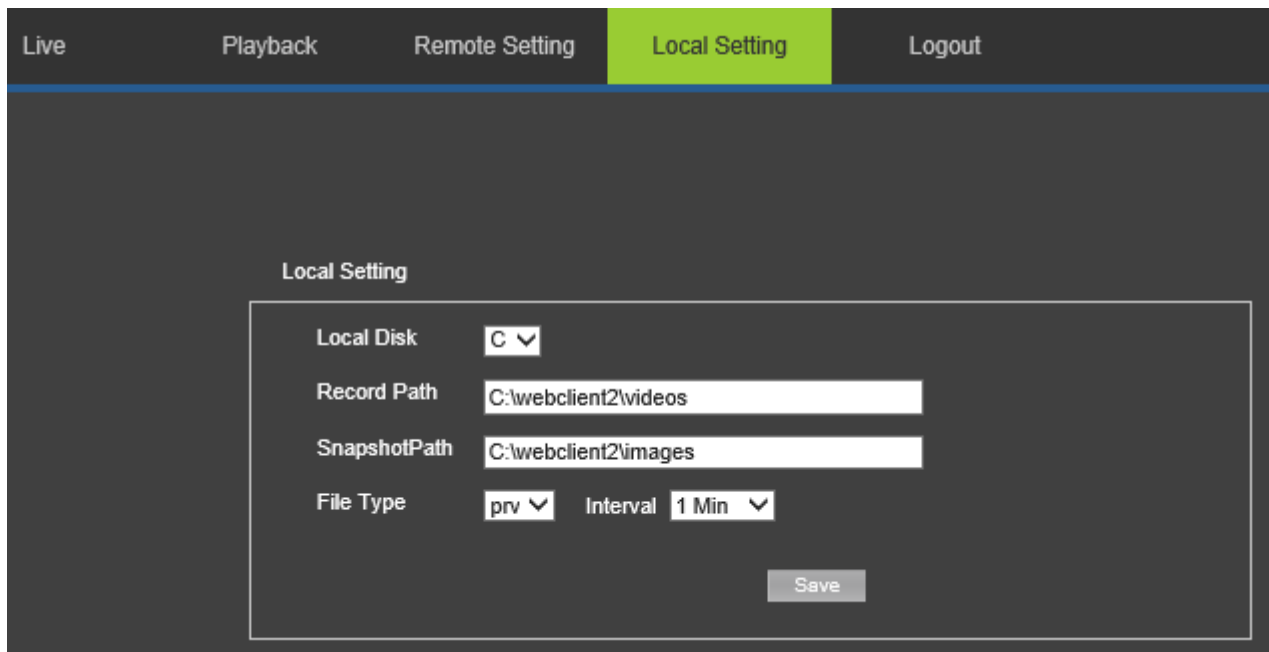

IMPORTANT: to make the local settings effective, especially to create the Record and Snapshot Path folders and to save Record Files and Snapshots, IE has to be executed with Windows Administrator privileges.

IMPORTANT: files that are recorded using IE and saved in the PC local folder have .264 format. To play these files it is necessary to use the corresponding Video Player software available in the CD or on the website www.urmet.it.

7.5 OUTPUT

Click on **Logout** to close the web interface of the IP camera:



8 VIEWING FROM APP

With the camera already configured and connected in 4G, connect the smartphone to the Wi-Fi network of the camera (SSID Wi-Fi : "MIFI_...", Wi-Fi password: 1234567890):



Download the **V-Stream** app from the store and, if you do not have an Urmet Cloud or Yokis account, click on **Sign Up** to create a new account. Check your inbox. You will receive an email to confirm your registration and activate your Urmet Cloud account. Enter your credentials and select **Login**.

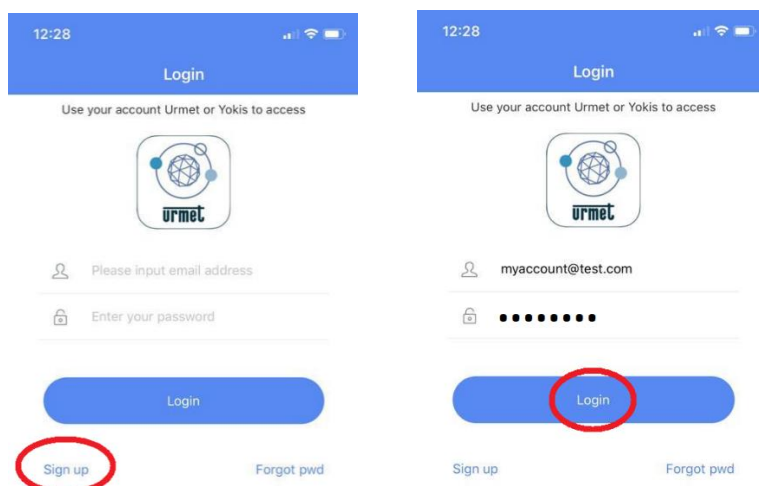

Press + to add a new camera and select **Network Scan**. Click on the detected network camera:

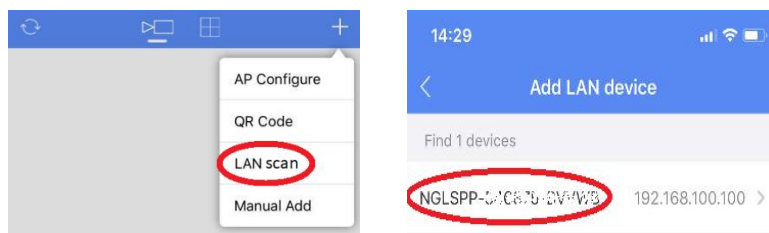

Fill in the camera password field (default: admin) and save. Press on the camera in the list to start the Live video:

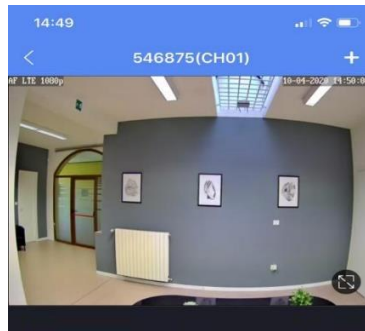
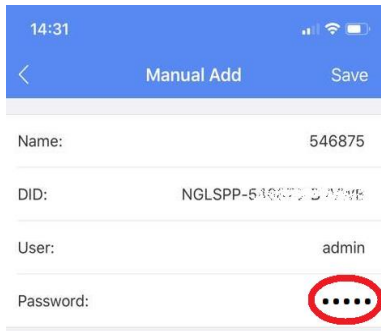

Alternatively, you can also connect the application to the camera by reading the QR code on the camera:

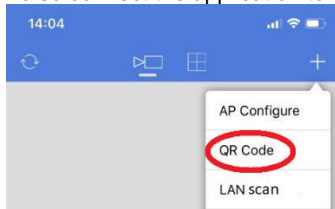

9 CONFIGURATION OF OTHER DEVICES

With the 1099/212B camera already configured and connected in 4G, you can connect to the Wi-Fi network of the camera (Wi-Fi SSID: "MIFI_...", Wi-Fi password: 1234567890) other Urmet Wi-Fi cameras (e.g. model: 1099/212B etc.). All cameras will be available via the Internet from the Urmet V-Stream app.

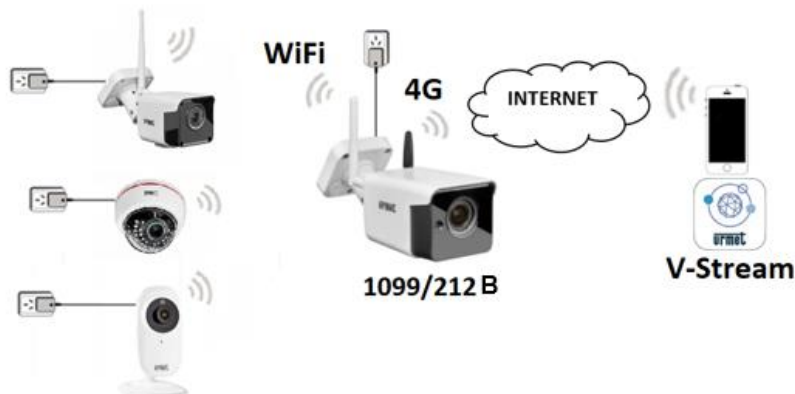

IMPORTANT: It is recommended not to connect more than 4 cameras to the 1099/212B Wi-Fi network of the camera. You can also use a network cable to connect an Urmet Series NVR/HVR (WAN port) video recording device to the network connector of the camera (WAN port). The HVR/NVR will automatically receive an IP address assigned by the 1099/212B camera DHCP service:



IMPORTANT: When recording cameras on NVR/HVR it is recommended not to connect more than 3 cameras to the 1099/212B Wi-Fi network of the camera

10 ROUTER 4G-WI-FI SETTINGS

With the camera already configured and connected in 4G, connect a personal device such as smartphone / tablet / PC to the wifi network of the camera (wifi SSID: "MIFI _...", wifi password: 1234567890) or connect a PC via cable to the network connector the camera.

Open the 4G / WiFi router management web page from any internet browser (ex. Chrome, Firefox) by typing the URL: <http://192.168.100.1/>

Enter the password (default: admin) to **login**.

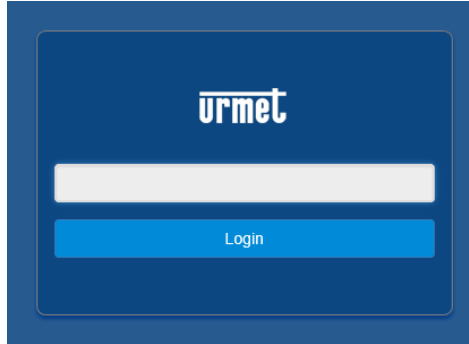

On the home page you can view: the type of transmission and the 4G signal level (1), the status of the Internet connection (2), other details (3):

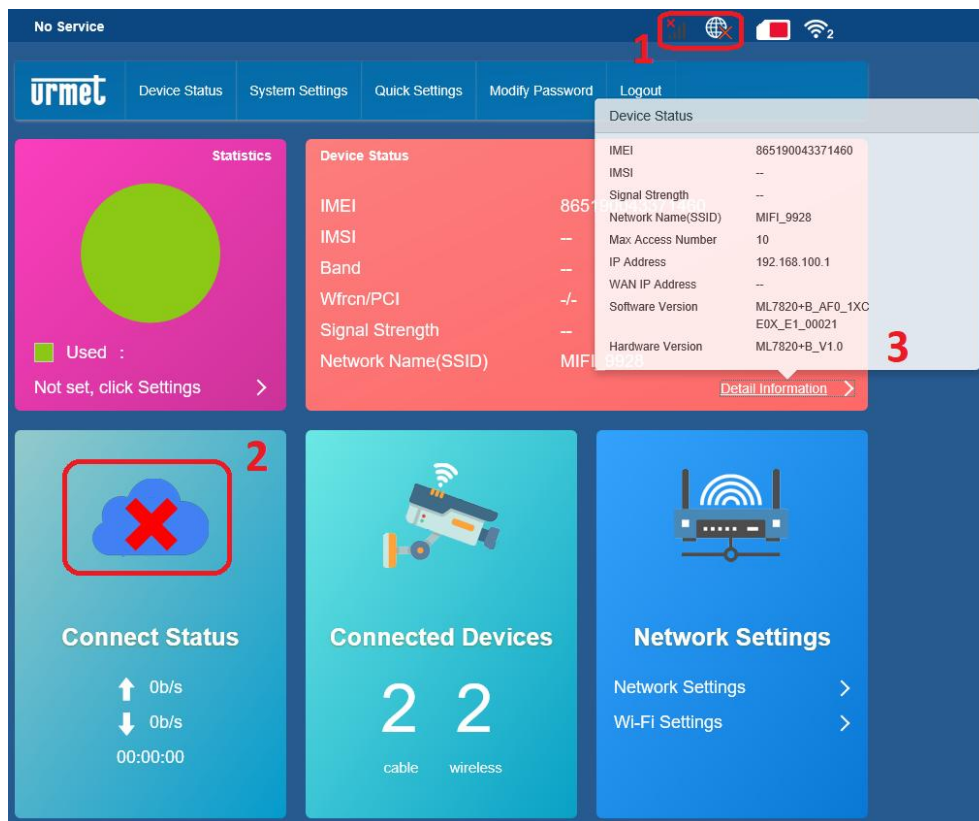

10.1.1 DEVICE STATUS

Click on Device Status to access the following interface

- 1) Device Status: this section contains the main info about the LTE device

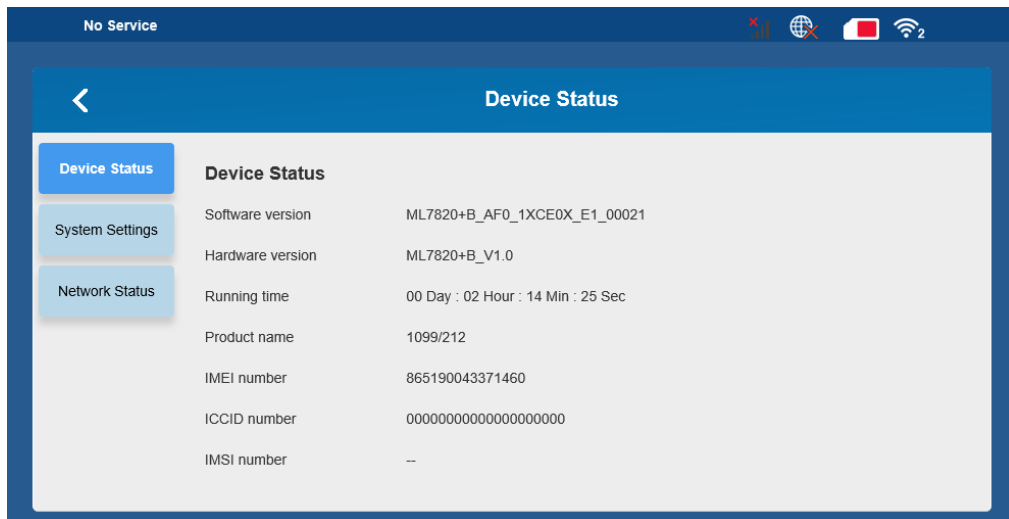

2) System Status: this section shows the main parameters of the router's LAN network configuration

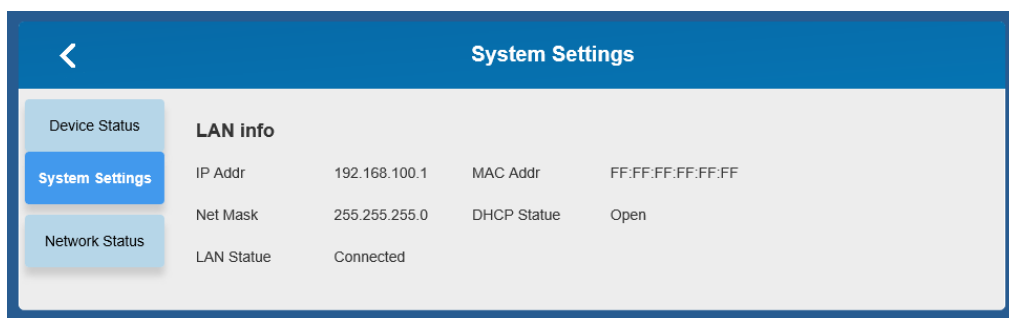

3) Network Status: this section shows the main parameters of the status of the LTE network configuration assigned by the operator

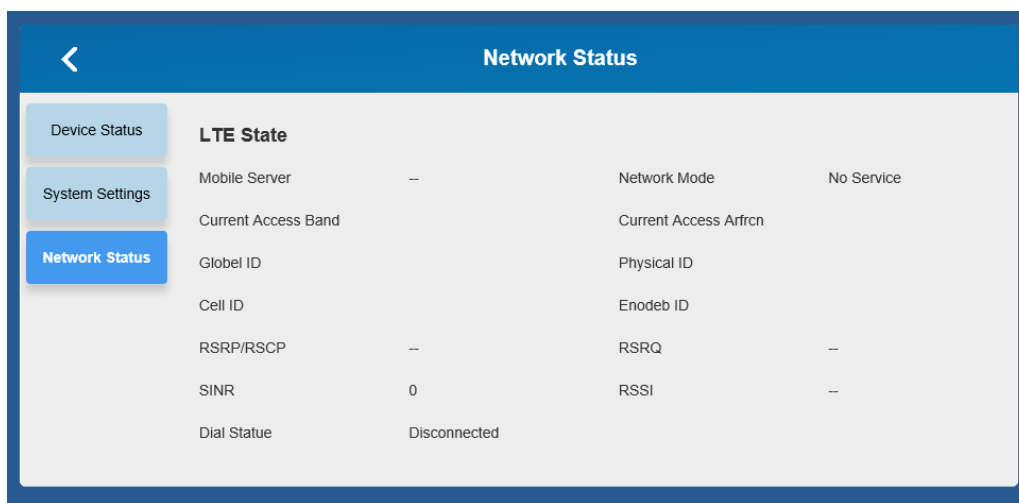

10.1.2 SYSTEM SETTINGS

Click on System settings to access the following interface

- Router: in this section it is possible to modify and set the LAN parameters of the LTE router. By default the DHCP Server is active and the router address is 192.168.100.1 with netmask 255.255.255.0

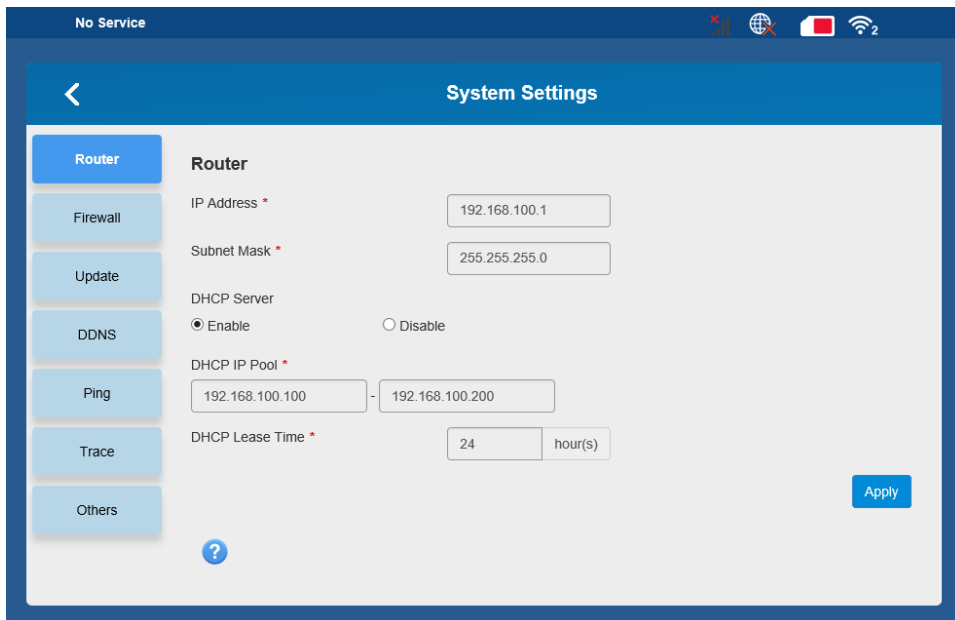

2) Firewall: in this section it is possible to insert rules for input and output data

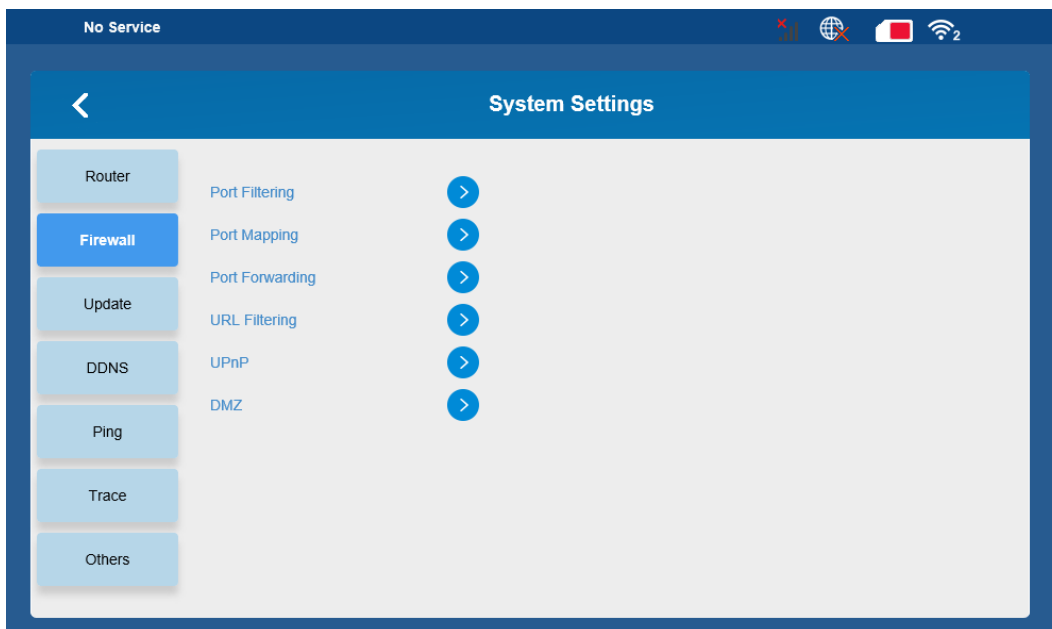

a. Port filtering: it allows you to filter (accept / reject) packets coming from / destined to a specific device

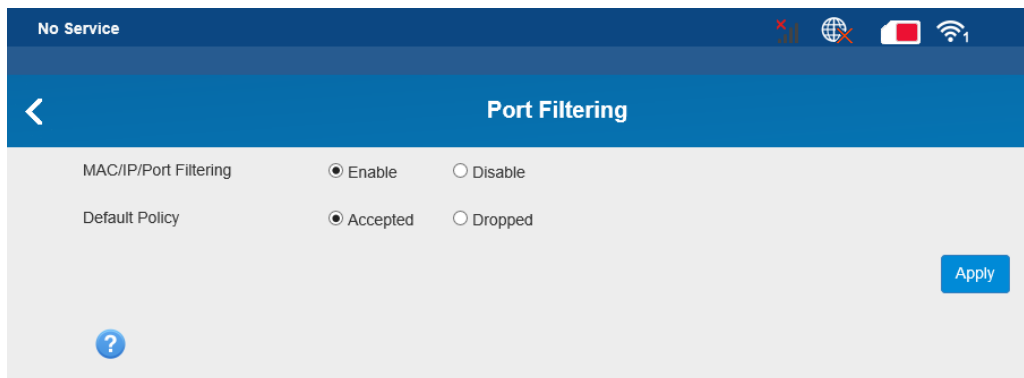

Select "Apply"

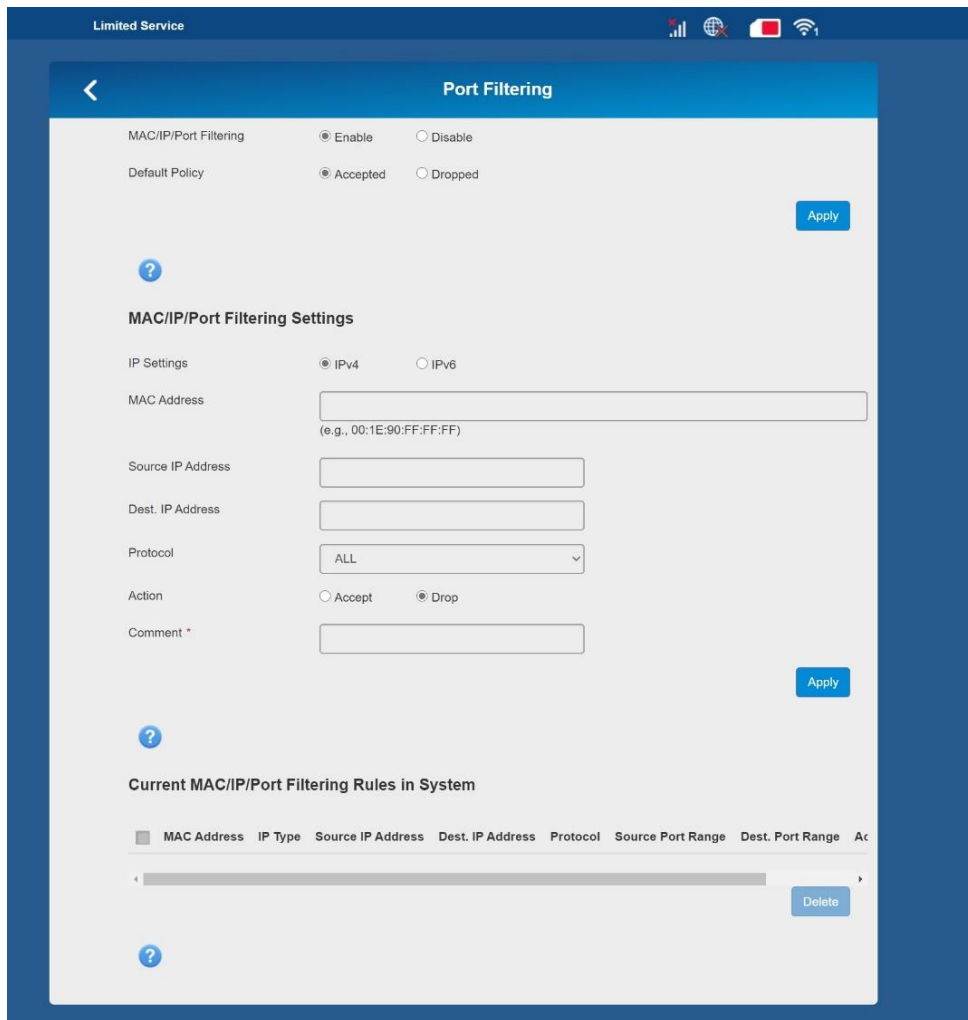

- b. Port Mapping:
Select "Enable" and "Apply"

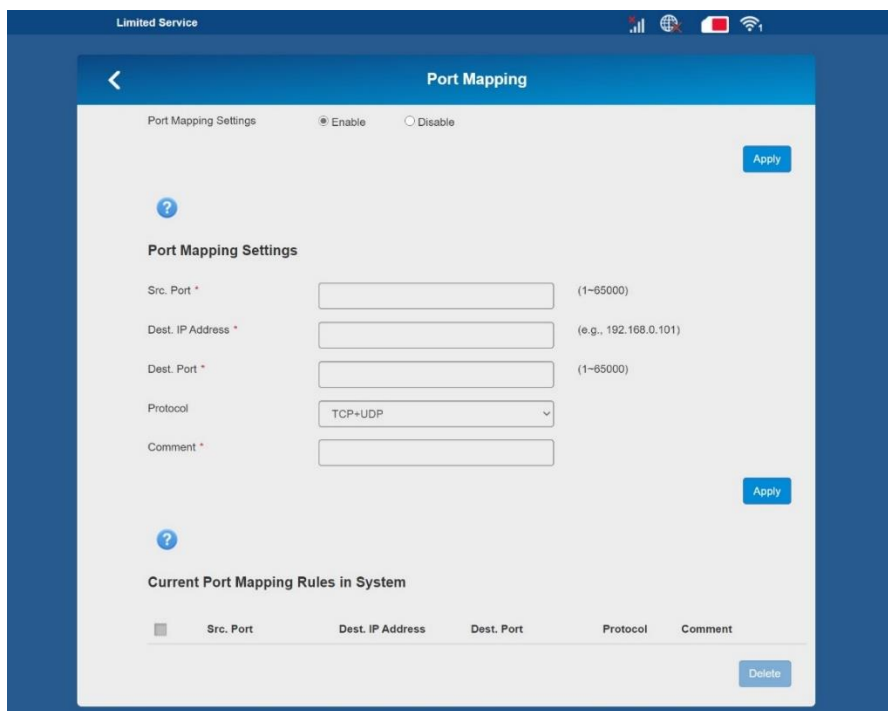

- c. Port forwarding:

Select "Enable" and "Apply"

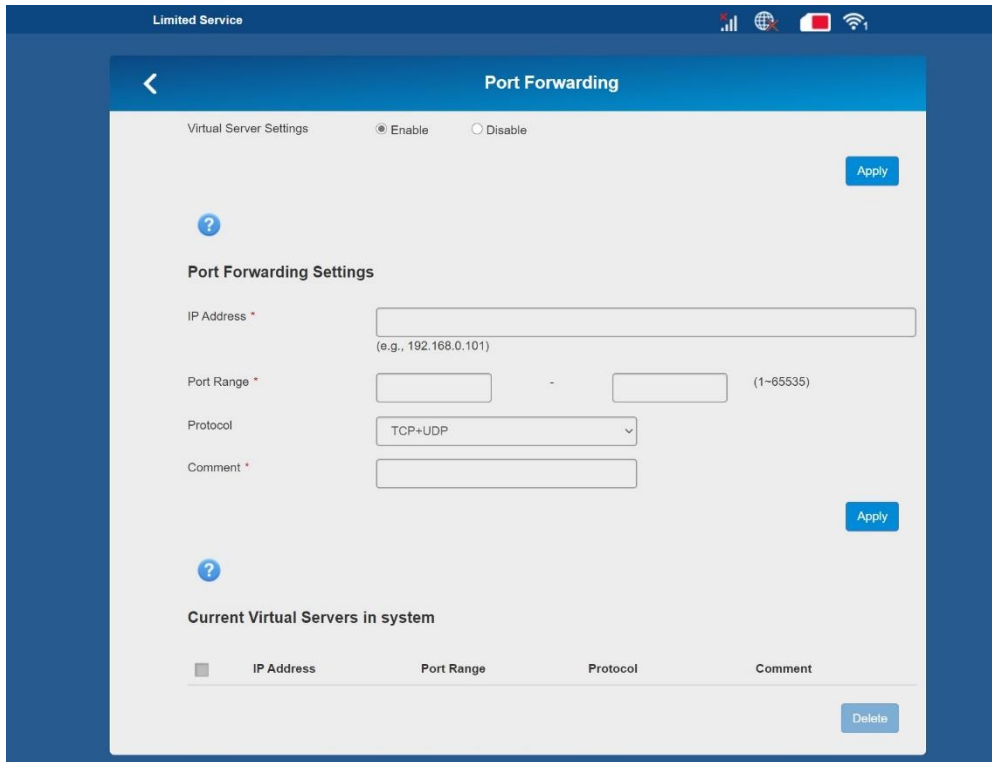

- d. URL filtering: in this section you can selectively block URL
- e. UPnP: in this area it is possible to enable / disable the function to automatically open certain ports on the router.
- f. DMZ: this functionality of the router allows to divert, without checking its reliability, all traffic coming from the Internet to a specific network device, which will then manage and protect the traffic

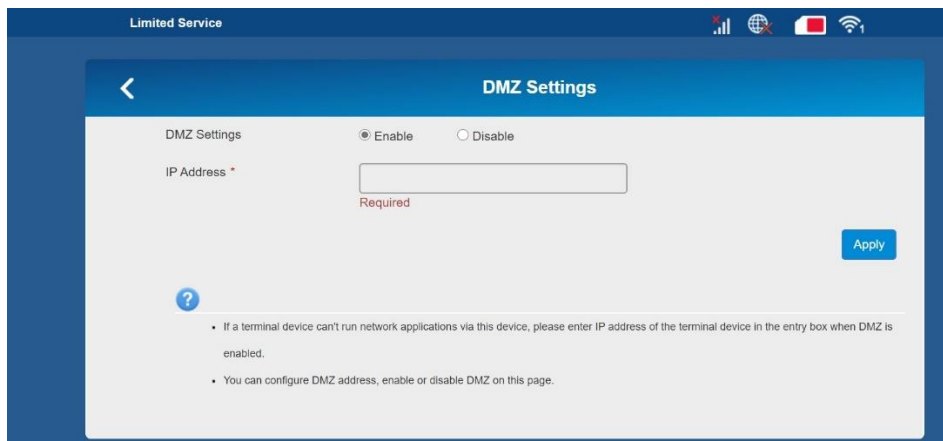

3) Update: In this section it is possible to update the FW of the camera LTE module

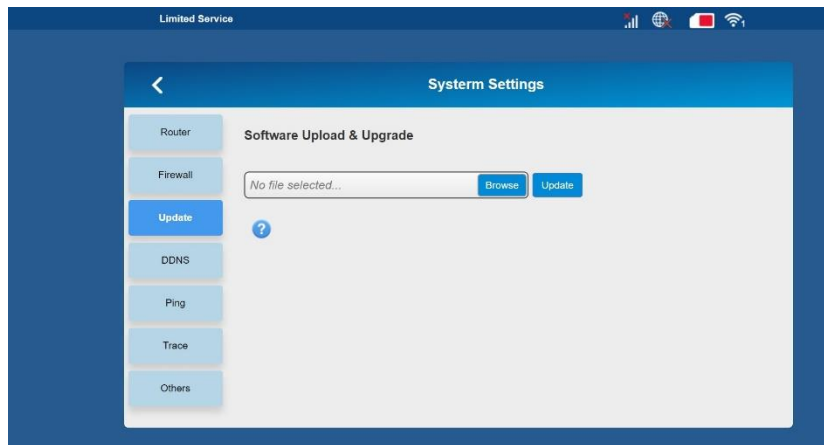

- 4) DDNS: It refers to the Dynamic Domain Name Server, which allows you to reach the router through the internet in case of connection with a dynamic public IP address.

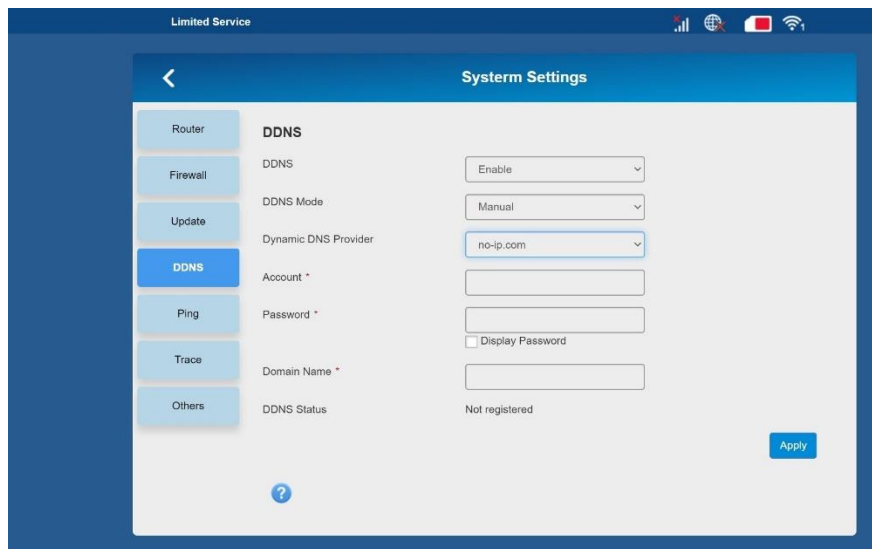

- 5) Ping: in this section you can perform a ping test to a certain URL / IP address to check the reachability of a site / device

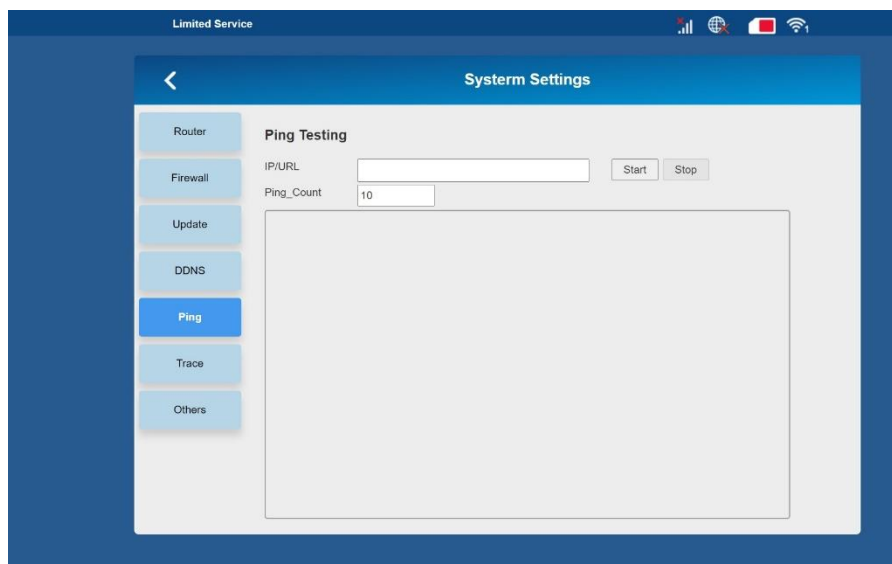

- 6) Trace: in this section it is possible to make a trace route to an IP site / device

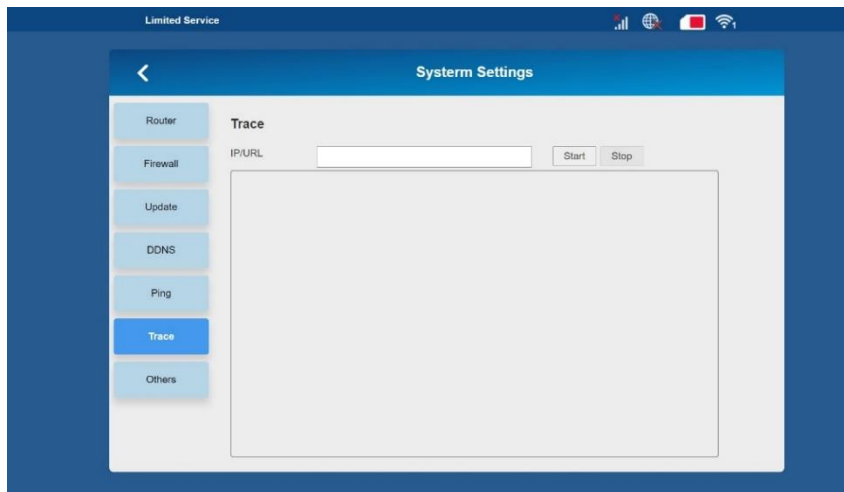

7) Others: in this section it is possible to configure the NTP, SMTP, time zone, manage the PIN (Pin Management) and restore the camera to the factory parameters

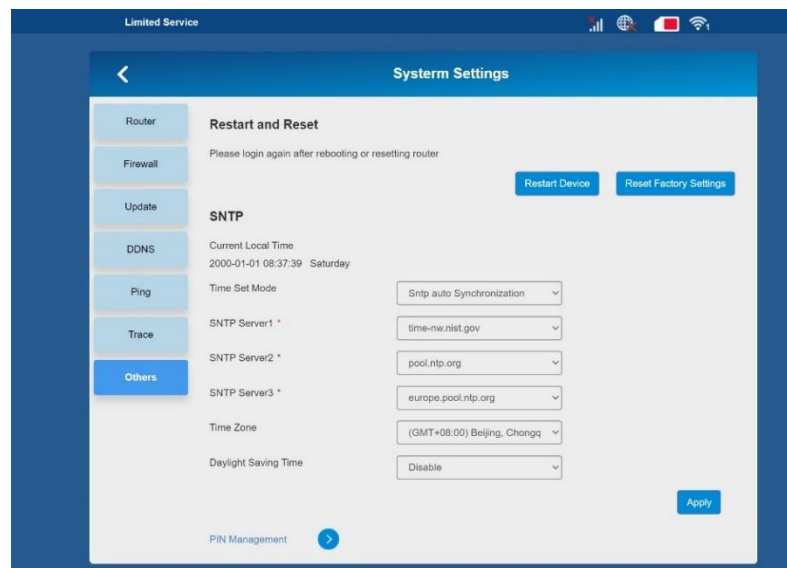

To manage the SIM PIN first disable the 4G connection and then press on **PIN Management**:

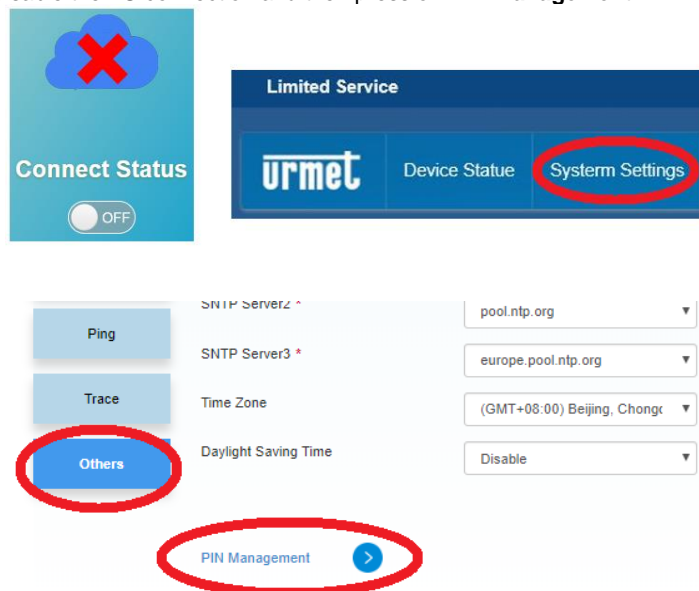

We suggest that the PIN is always on **Disable**:

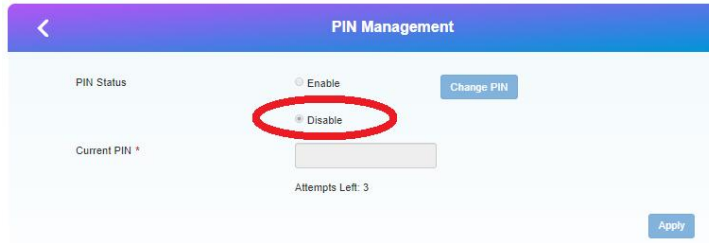

To reset the 4G / Wi-Fi router to factory settings, press **Reset Factory Settings**:

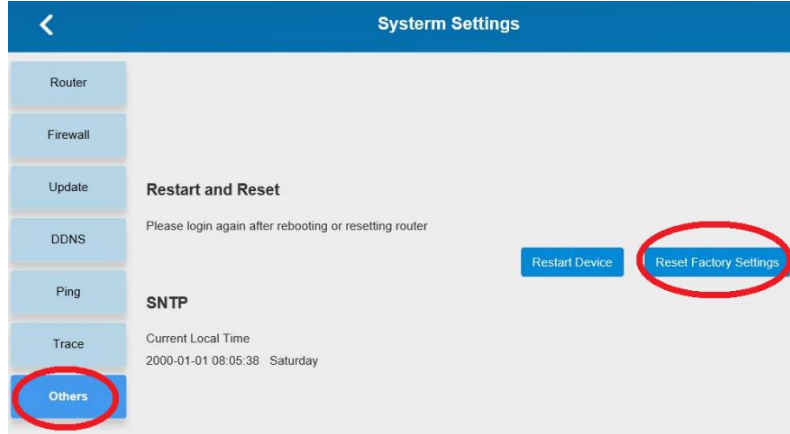

10.1.3 QUICK SETTINGS

Click on Quick Settings to access the following interface.

Through this menu you can quickly change the basic settings of the 4G / Wi-Fi router (example: APN, Wi-Fi SSID, Wi-Fi password). Pressing Next continues to modify all the main parameters

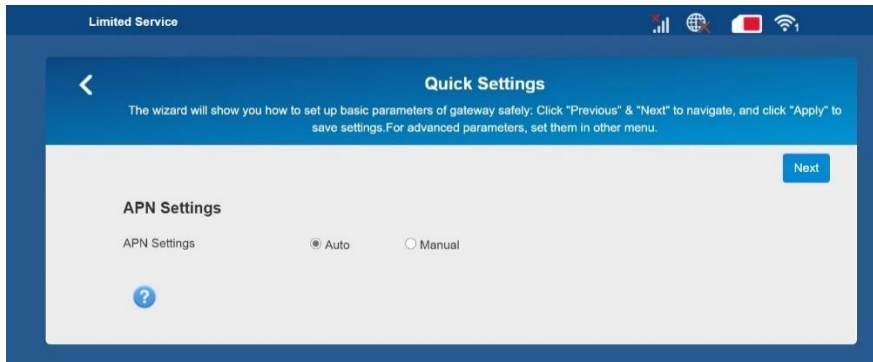

10.1.4 MODIFY PASSWORD

Click on Modify password to change the password to access the 4G / Wi-Fi router web page and to access the following interface

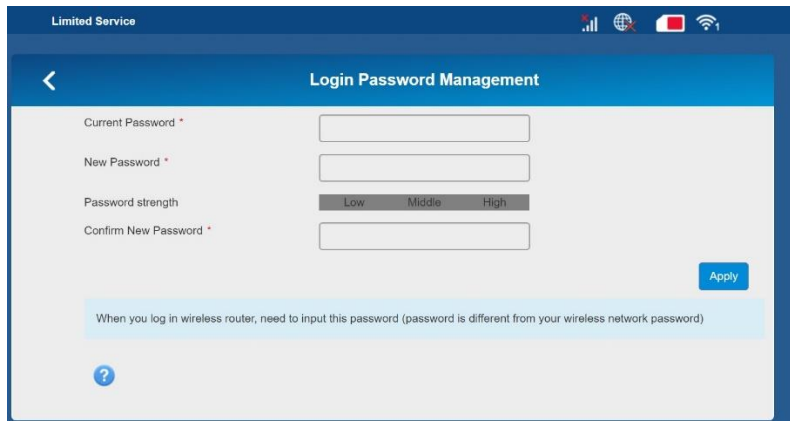

10.1.5 STATISTICS

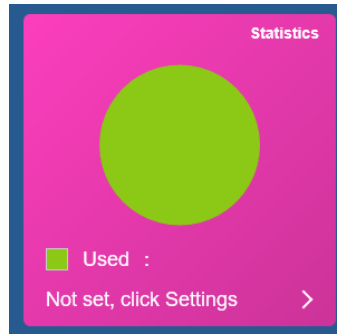

Use of sim card data.

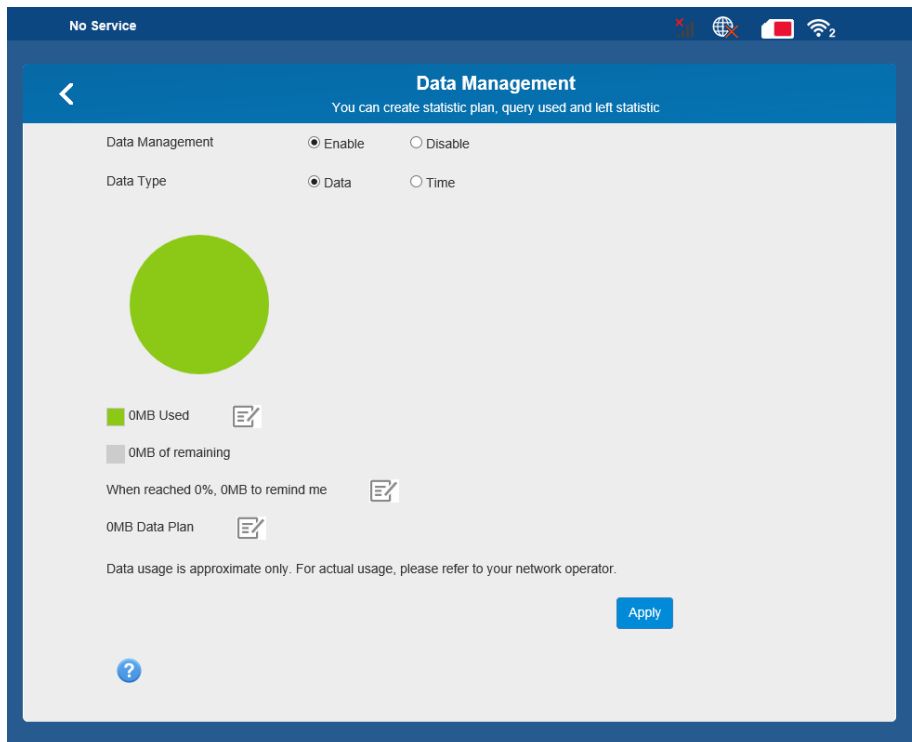

10.1.6 CONNECTED DEVICES

In this section you can see all the devices connected to the camera, both wired and via Wi-Fi.

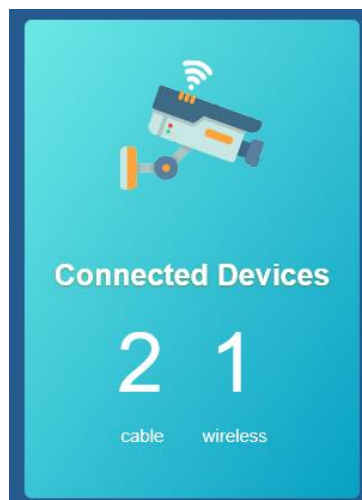

No Service

Connected Devices

All of wireless devices connected to this router will show on the page, including device name and MAC address

Wireless Access Device			
No.	Host Name	MAC Address	IP Address
1	sistemi	FC:F8:AE:45:13:70	192.168.100.104

Cable Access Devices			
No.	Host Name	MAC Address	IP Address
1	sistemi	F0:1F:AF:6B:91:2A	192.168.100.101
2	--	5A:58:65:1D:37:F5	56.58.54.53

10.1.7 NETWORK SETTINGS

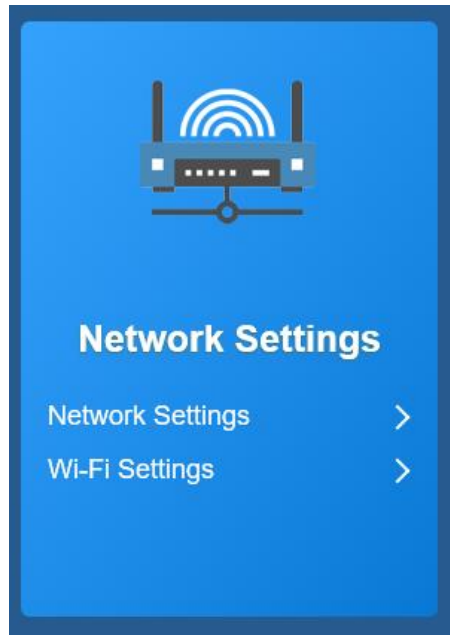

In this section it is possible to manage the WAN connection with the telephone operator

- 1) Connection mode: in this section you can determine if you want to connect to the internet manually or automatically and if you want to allow the connection in case of roaming.

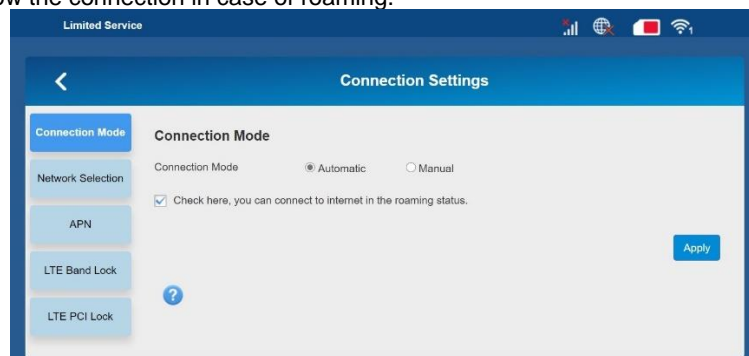

- 2) Network selection: in this section you can choose whether to select the network operator automatically or manually

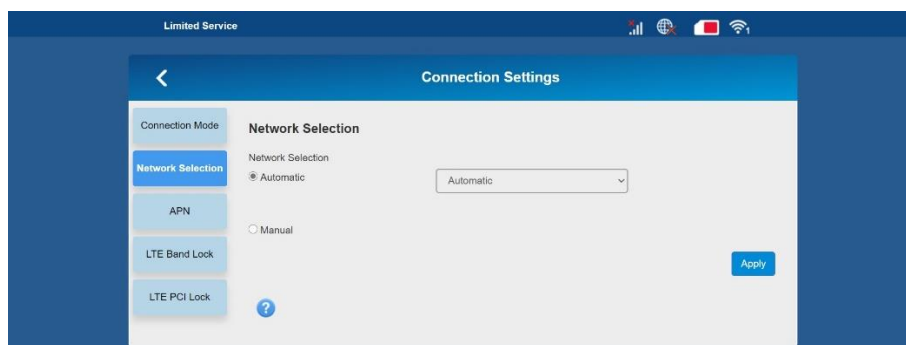

- 3) APN: in this section it is possible to create an APN profile, the username and password fields normally are empty

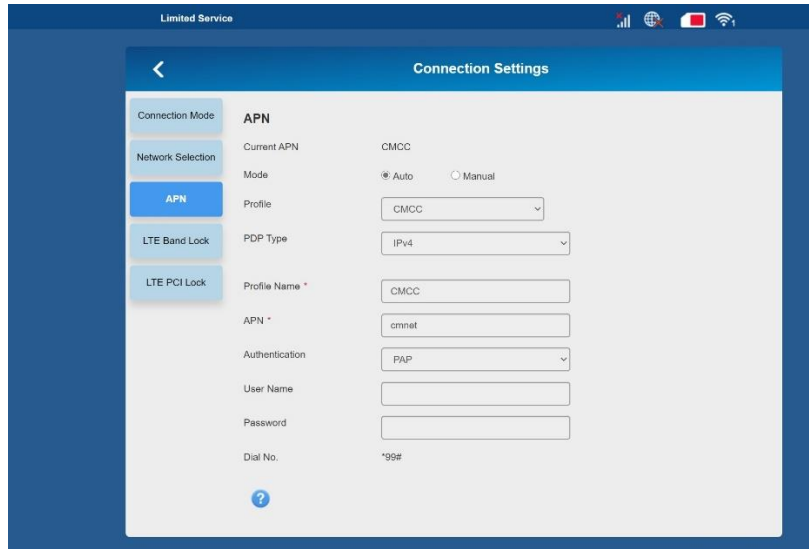

- 4) LTE Band Lock
 in this section it is possible to disable the frequency bands to which you do not want to connect

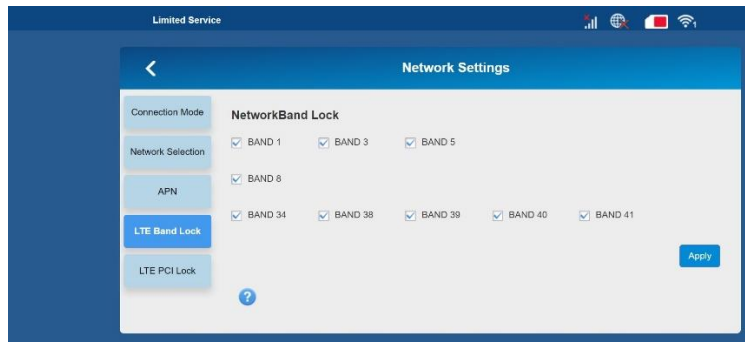

- 5) LTE PCI lock
 In this section it is possible to block the LTE modem by allowing the connection only with credentials

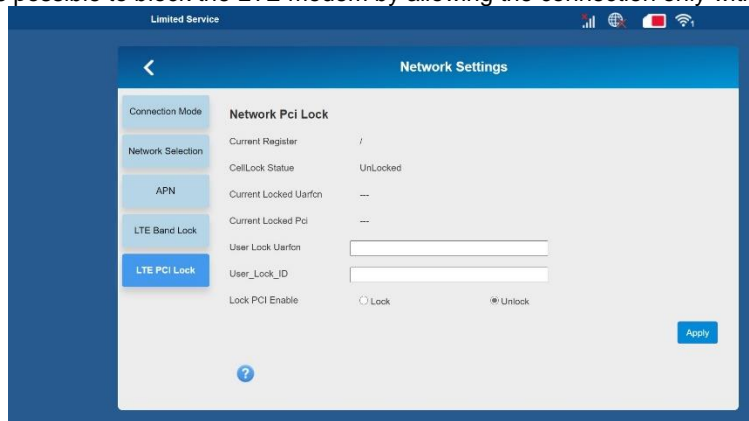

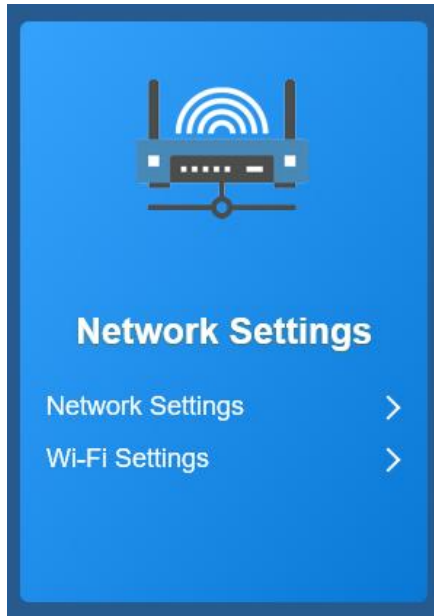

In this section it is possible to configure the parameters of the Wi-Fi network generated by the camera

- 1) **Wi-Fi SSID:** in this section you can set the name of the selected network (SSID), the type of encryption, the password and the maximum number of users connected to the network. It is also possible to disable the Wi-Fi network if it is not used

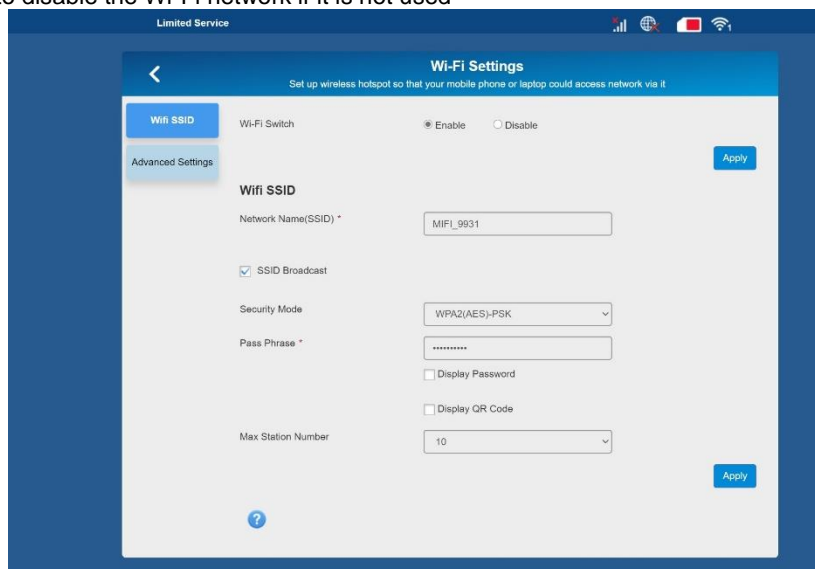

- 2) **Advanced Settings:** In this section it is possible to define the type of transmission protocol, the bandwidth, the country and the channel to be used

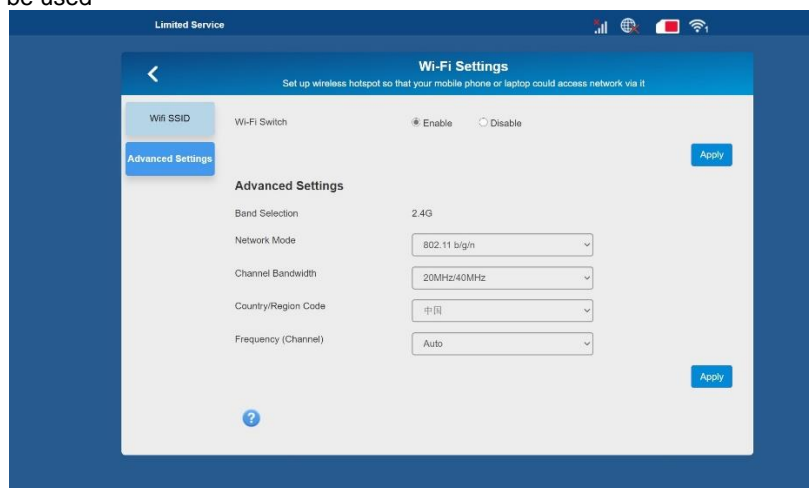

11 TECHNICAL SPECIFICATIONS

GENERAL DATA	1099/212B
Max absorption	Typ: 180mA(D), 460mA(N). Peak 480mA (when IR CUT moves D/N).
Power supply	12 Vdc / PoE
Dimensions (L x H x D)	189*76*68mm
Weight (g)	650g
Type of housing	Bullet
Housing color	Black and White
Operating conditions	-20°C~+60°C , <90%RH
Protection class	IP66
Video Format	Adaptive control P/N
MAIN FEATURES	
Camera sensor	1/2,9 CMOS 3MP
Camera lens	Motorized varifocal 2.8-12mm, F1.6
Field of vision (horizontal)	W H97.1° T H32.3°
Electronic shutter (s)	1/3 ~ 1/10.000s
Sensitivity (lux)	0.1Lux@(F1.2,AGC ON), 0 Lux with IR Cut
IR filter	Mechanical with auto switch
Video resolution (H x V)	3MP (2304x1296)
Video compression rate	128Kbps – 12288Kbps
SOFTWARE/FIRMWARE FEATURES	
Video compression	H.265, H.264
Frame-rate	Mainstream 2304x1296 @ 15fps 1920x1080 @ 20fps 1280x720 @ 25fps Substream 704x576 @ 25fps 640x360 @ 25fps
Supported protocols	HTTP, TCP/IP, IPv4, RTSP, UDP, SMTP, NTP, DHCP, DNS, IP Search
WiFi	802.11 b/g/n
WiFi frequency	2.4GHz~2.4835GHz
LTE	band 1,2,3,5,7,8,20,34,38,39,40 e 41 gain 2dBi
Security	64/128-bit WEP [non supportato], WPA/WPA2, WPA-PSK/WPA2-PSK
Web/Client/ Mobile	Multi browser (Edge in I.E. mode, Chrome, Safari, Firefox, Opera) Mobile Software (iOS, Android)
FUNCTIONS	
Image setting	Adjustment of: brightness, sharpness, contrast, saturation, via web page, smartphone App, HVR/NVR
Motion detection (zone)	YES
Video analysis	Motion detection, Human
DNR control	3D DNR
Backlight compensation	BLC / D-WDR
WiFi antenna	External
Audio	Integrated microphone
Max N. Stream / PC access	2 Mainstream + 2 Substream
HARDWARE FEATURES	
No. of IR LEDs / Lighting distance (m)	2 EX LED 850nm (25 m – 30m)
Micro-SD card slot (card not included)	YES, Max 128GB
LAN type	RJ45 10M / 100M Ethernet
Connector	RJ45 waterproof

Dimensions

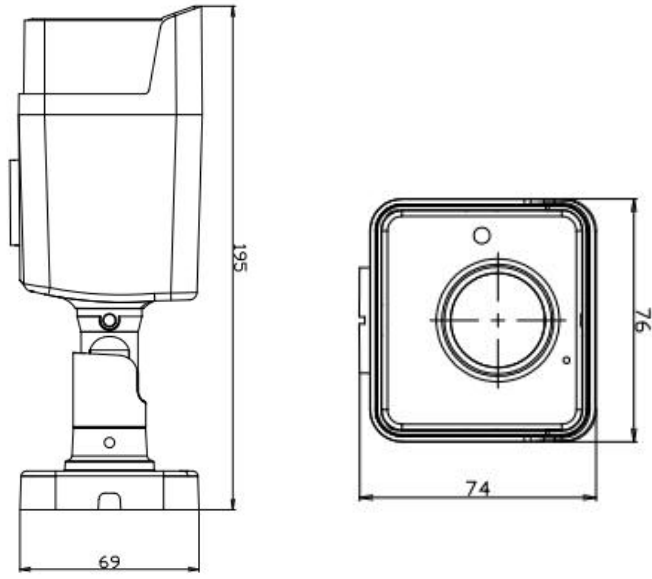

12 APPENDIX

12.1 FAQ

- ◆ **IE does not load or install the plug-ins.**
 1. Possible cause: The IE protection setting is too high.
Solution: Set IE protection to minimum level.
- ◆ **After updating, the user cannot inspect the IP camera using IE.**
 1. Solution: Flush the IE cache. Specific operations: Select the IE Tools menu, select Internet Options, click on Delete file on the 2nd option (Temporary Internet files), click on Delete all offline contents and click on OK. Connect to the IP camera again.
- ◆ **Why can't I inspect the IP camera using IE?**
 1. Possible cause 1: Network error or fault.
Solution: Connect the PC to the Internet and check that it accesses the network correctly. Check for wiring or network problems caused by virus on the PC by pinging the PC.
 2. Possible cause 2: The IP address is occupied by other devices.
Solution: Disconnect the IP camera from the network, connect it to the PC and set the IP address of the device.
 3. Possible cause 3: The IP address relates to a different subnetwork.
Solution: Check IP address settings, subnetwork mask and gateway.
 4. Possible cause 4: The physical address of the network is conflicting with the IP camera.
Solution: Change the physical address of the IP camera.
 5. Possible cause 5: The web port has changed.
Solution: Contact the network manager to obtain the corresponding information on the port.
- ◆ **I cannot see the remote device video on the PC**
 1. Solution: Check that the IP camera video can be normally displayed in IE, that the device can be searched using the PC software and that the parameters of the device on the PC client are set correctly.

DS1099-183

URMET S.p.A.
10154 TORINO (ITALY)
VIA BOLOGNA 188/C
Tel. +39 011.24.00.000 (AUTO)
Fax +39 011.24.00.300 - 323



Technical area
Customer Care+39 011.23.39.810
<http://www.urmet.com>
e-mail: info@urmet.com
MADE IN CHINA