



Vallox 110^{SE}

Code
3700
Models
VALLOX 110 SE R
VALLOX 110 SE L

**Low-energy ventilation unit with heat recovery
and demand-controlled automatic melting**

© Vallox
1.09.422 E
19.6.2012

Operating, maintenance and technical instructions



- 1 Extract air fan
(behind protective cover)
- 2 Supply air fan
(behind extract air duct)
- 3 Outdoor air filter F7
- 4 Heat recovery cell
- 5 Summer/winter damper
- 6 Outdoor air filter G4
- 7 Extract air filter G4
- 8 Post-heating radiator
(behind extract air duct)
- 9 Safety switch
- 10 Additional heating radiator
- 11 Control panel DIGIT SED
- 12 Carbon dioxide sensor
- 13 Humidity sensor

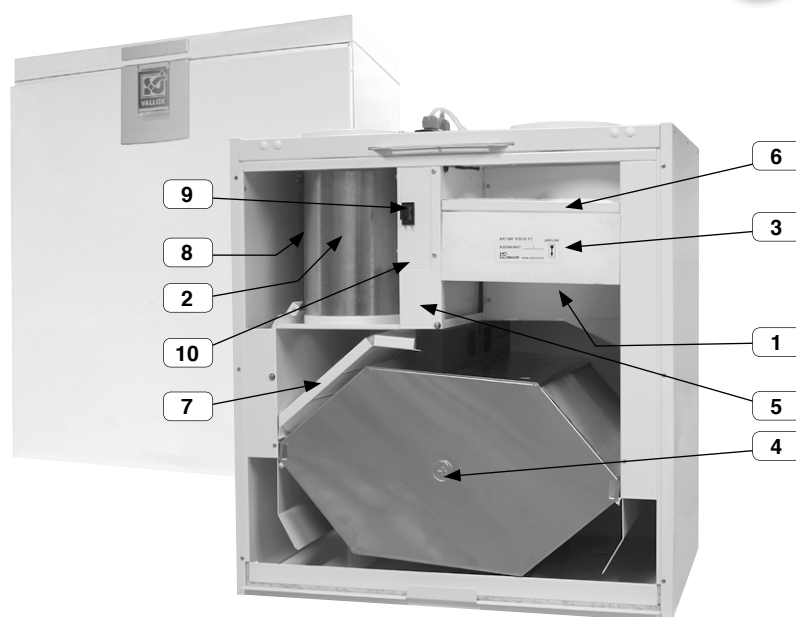

The figure shows the R model



TECHNICAL DATA

Electrical connection	230 V, 50 Hz, ≈ 9.6 A (plug)
Degree of protection provided by enclosures	IP34
Fans	Extract air 113 dm ³ /s 100 Pa
direct current (DC)	Supply air 107 dm ³ /s 100 Pa
Heat recovery	Cross-counter flow heat recovery cell, $\eta > 80\%$
Heat recovery bypass	Automatic
Electric post-heating unit (standard)	900 W, 3.9 A
Additional heater	900 W, 3.9 A
Fans	Supply air G4 and F7
	Extract air G4
Weight	60 kg
Ventilation power adjustment	- control panel control - CO ₂ and %RH control - remote monitoring control (voltage signal)
Options	- CO ₂ sensor - %RH sensor - Insulated attic floor penetration plate - Ceiling mounting plate Vallox 110

Operating instructions VALLOX 110 SE

For indoor air to stay healthy and beneficial also for the structures of the dwelling, ventilation has to be in operation continuously. It is not advisable to stop ventilation even for longer holidays because it makes indoor air stuffy. Also, during the heating season indoor air humidity may condense in the ducts and structures and therefore cause humidity damage. The sensors automatically adjust ventilation to an optimal level even if the dwelling is empty.

Making the unit ready for operation

1. Connect the plug to the mains supply. VALLOX 110 SE is now ready for operation.
2. Start the unit and choose a suitable ventilation power at the control panel. There is either one or more control panels. See the operating instructions for control panel.

In normal conditions basic ventilation, with a change of air every two hours, is sufficient in living areas. Boosting is needed during for example sauna baths, cooking, clothes washing or family parties. If carbon dioxide and/or humidity sensors have been installed in the system, VALLOX 110 SE automatically takes care of demand-controlled ventilation.

Ventilation control

The unit can be controlled with a control panel. The standard week-clock control can be used to control the fan power of the unit and the setpoint for supply air temperature.

Furthermore, demand-controlled ventilation can be adjusted with optional carbon dioxide and humidity sensors.

The fan power of the unit can also be controlled with a voltage signal.

Controlling ventilation with Vallox Digit SED control panel

The control panel can be used for the following ventilation control functions:

Functions for adjusting ventilation power

- Starting and stopping.
- Power adjustment (8 positions).
- Setting the base fan speed and the maximum fan speed.



Ventilation power cannot be set lower than the base fan speed. When carbon dioxide and/or relative humidity adjustments are activated, power cannot be adjusted higher than the maximum fan speed. When humidity and carbon dioxide adjustments have been switched off, fan speed can be raised to speed 8. (See the operating instructions for control panel, Section 3.25.)

Ventilation control with carbon dioxide sensor (option)

- In carbon dioxide control, VALLOX 110 SE adjusts fan speed so as to keep carbon dioxide content in the ventilation zone below the setpoint. When two or more sensors are used, fan speed is adjusted according to the highest measuring result.
- 1 to 2 carbon dioxide sensors can be connected as options to the VALLOX 110 SE unit.
- The adjustment is switched on/off and, if needed, the setpoint (500...2000 ppm) is set at the control panel. The factory setting is 900 ppm. The recommended maximum carbon dioxide content in good indoor air is circa 1,000 ppm.
- During control, the control panel can be used to raise fan speed to the maximum fan speed and to decrease it to the base fan speed. In carbon dioxide control, maximum fan speed limitation is enabled.

Controlling ventilation with humidity sensor (option)

There are two modes of adjusting fan speed:

1. Automatic humidity setting, which is suitable for controlling humidity in for example washing rooms.

The program records current humidity level and selects it as the setpoint, which it then uses as the target for drying air in a bathroom, for instance after a shower. The setpoint automatically varies for instance according to season and is always at the right level. This setting is factory selected.
2. Humidity level can also be set fixed. The setting can range between 1...99 %RH and is set at the control panel. This can be used in for example public saunas and swimming pools. The program aims at keeping humidity at the setpoint. The setpoint can be changed if needed. The mode of adjustment is chosen at the controller. Recommended humidity content of good indoor air is approximately 45%.
 - During this control, the control panel can be used to raise fan speed to the maximum fan speed and to decrease it to the base fan speed.
 - In humidity control, fan speed varies between the base and maximum fan speeds selected.
 - When the unit is first taken into use with automatic setpoint search enabled (factory setting), it takes 3 to 10 hours for the program to define the value. During this time, humidity adjustment is not enabled (because the first value, selected at the factory, is 100%).
 - Automatic search is enabled even if humidity control is not selected.



Carbon dioxide and humidity sensors

Controlling ventilation with voltage signal

- VALLOX 110 SE fan power can be controlled with a voltage signal coming from remote monitoring.
- The signal can be used to select speeds 0 to 8. However, if carbon dioxide or humidity adjustment is enabled, the maximum fan speed cannot be exceeded. (See the operating instructions for control panel, Section 3.25.)
- The signal changes the base fan speed.
- The signal does not lock fan speed, i.e. fan speed can be changed at the control panel within the set limits. Carbon dioxide and humidity adjustment also operate within the set limits.

Voltage signal values

Voltage values for each fan speed:

0	0.20...1.25 VDC
1	1.75...2.25 VDC
2	2.75...3.25 VDC
3	3.75...4.25 VDC
4	4.75...5.25 VDC
5	5.75...6.25 VDC
6	6.75...7.25 VDC
7	7.75...8.25 VDC
8	8.75...10.00 VDC

OPERATING INSTRUCTIONS

Adjustment of supply air temperature and summer/winter function

The temperature of air coming to the dwelling can be adjusted between circa +10 °C and +30 °C. When there is a light on the post-heating indicator, post-heating is activated and the unit heats air as needed. The need for heating depends on the setpoint of supply air temperature.

When there is no light on the post-heating indicator, post-heating is off. This means that the summer function is activated for the ventilation unit. The unit has a motorised summer/winter function. When the summer function is on, the heat recovery cell is bypassed as soon as outdoor air temperature has risen above the setpoint. See the setpoint for cell bypass, factory setting +12 °C. When outdoor air temperature goes below the setpoint (factory setting +12 °C), the unit starts to recover heat.

Two different kinds of supply air temperature adjustment can be chosen at the unit: constant temperature control or cascade control. In constant temperature control, the unit controls the temperature of supply air directly in accordance with the measurement information on the temperature of supply air blown to the ventilation area. In cascade control, the unit controls supply air temperature according to the temperature of air extracted from the ventilation area. The unit calculates the difference between the air extracted and the setpoint for supply air and uses this difference to control the need for post-heating.

Winter function of ventilation unit

A set of parameters has been set at the factory for the freezing of the heat recovery cell (3.21 and 3.22). When these parameters are undercut, the ventilation unit melts the heat recovery cell utilising the heat of extract air. Melting is done by stopping the supply air fan (factory setting) or by bypassing the heat recovery cell from the supply air side (3.20. Choosing melting mode).

If the bypassing the heat recovery cell is chosen as the melting mode, the relationship between the supply and extract air flows does not change. This prevents the formation of a vacuum inside, which may be harmful in some cases. In this case the electric resistor heats the cold air coming from outside during the melting period to the temperature desired (2.6. Setting supply air temperature). If the

Remember!
Switch post-heating off when it starts to get too warm in the dwelling because of warm weathers.
Switch post-heating on again when it gets cooler in autumn.

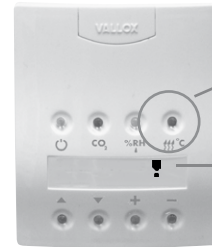

Post-heating indicator light

Maintenance reminder symbol

Maintenance reminder

- The maintenance reminder switches on the maintenance reminder symbol (⚠) on the main display of the control panel at defined intervals, the factory setting being 4 months.
- The maintenance reminder symbol is acknowledged at the main display of the control panel. (See the operating instructions for control panel, Section 3.1.)
- The interval can be set between 1 and 15 months at the control panel.

temperature desired is high compared to outdoor air temperature, the unit decreases the supply and extract air flows in order to attain the desired supply air temperature.

A normal melting period varies from 15 to 45 minutes depending on the amount of ice and the volume of the extract air flow.

The unit operates optimally on the factory settings in normal operation in dwellings and detached houses. The parameters only need to be touched in extreme problem situations. Examples of such situations are high humidity loads such as a swimming pool or if there is a detrimental amount of ice in the exhaust air duct.

Fireplace switch function/booster

Fireplace switch function

(See the operating instructions for control panel, Section 3.12.)

- The fireplace switch stops the extract air fan for 15 minutes and produces overpressure in the ventilation zone. This makes it easier to light a fireplace.

The function is started on the main display of the control panel by simultaneously pressing and holding down the + and – buttons for 2 seconds.

- The function can also be started at a separate auto-reset push-button switch, wired from the connection box of the unit for example to a wall in the fireplace room. Upon each pressing, the stopping function continues for 15 minutes (the switch is not included in the delivery).
- During the function, the fireplace/booster switch symbol (⚡) is visible on the main display of the control panel.

NOTE! The starting of the extract air fan may weaken draught in the fireplace! In winter, this situation may disturb the winter function of the unit. The situation will normalise in a while, after the fireplace function stops.



Fireplace/booster switch symbol

Booster switch function

(See the operating instructions for control panel, Section 3.12.)

- The booster switch function raises fan speed to the set maximum fan speed for 45 minutes.

The function is started on the main display of the control panel by simultaneously pressing and holding down the + and – buttons for 2 seconds.

- The function can also be started at a separate auto-reset push-button switch, wired from the connection box of the unit to for instance a wall in a classroom. Upon each pressing, the boosting function continues for 45 minutes.
- During the function, the fireplace/booster switch symbol (⚡) is visible in the main display of the control panel.
- The function is chosen at the control panel.

Fault signal relay (remote monitoring)

- The fault signal relay has potential-free contacts (24 VDC, 1 A).
- The contacts provide information on various failure modes of the unit.
- Alarm of high carbon dioxide content switches the relay at 1-second intervals.
- In other fault situations, the contacts are closed.

1. Control panel operation

1.1 Keyboard



- 1 Start button**
Press the button to turn the ventilation unit on and off. When the indicator is lit, the unit is on.
- 2 Carbon dioxide adjustment**
Press the button to turn carbon dioxide adjustment on and off. When the indicator is lit, the adjustment is on.
- 3 Humidity adjustment**
Press the button to turn humidity adjustment on and off. When the indicator is lit, the adjustment is on.
- 4 Post-heating**
Press the button to turn post-heating on and off. The summer function is on when the indicator is not lit.

- 5 Scrolling up**
With this button you can scroll the displays upward.
- 6 Scrolling down**
With this button you can scroll the displays downward.
- 7 Increase button**
Use this button to increase values.
- 8 Decrease button**
Use this button to decrease values.

Power failure

After a power failure, the unit starts at minimum fan speed. The adjustments and setpoints chosen will remain in the memory of the unit in spite of the power failure.

Ventilation operating menus

2. Operating menu

The displays of the Operating menu (Sections 2.1–2.6) can be scrolled with the scrolling buttons (see Section 1, figure items 5 and 6).

2.1. Main display and change of fan speed

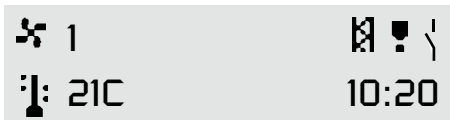

Main display

Main display

Fan speed can be changed in this display with the + and – buttons (see Section 1.1, figure items 7 and 8).

- 3 Fan speed (3).
- 21 Supply air temperature (21°C).
- 10:20 Time.
- Filter guard alarm.
- Maintenance reminder alarm.
- Fireplace/booster switch on. The fireplace/booster switch is activated in this display by simultaneously pressing down the + and – buttons for 2 seconds.
- Week-clock control on.

2.2 Moving to the Settings menu

To settings menu
see manual

In order to move to the Settings menu, press the + and – buttons simultaneously. In the Settings menu you can change setpoints for the ventilation unit.

2.3 Week-clock control

Week program
on

Week-clock control can be switched on with the + button and off with the – button. Week-clock control is on when the week-clock control symbol is in the main display. In week clock control, the base fan speed and supply air temperature of the unit are adjusted in accordance with the programme as described in Section 4.1.

2.4 Content display

RH 35% RH2 40%
CO2 0821 PPM

The content display shows humidity and carbon dioxide content. The corresponding sensors are required (options).

2.5 Temperature display

Out 20 in 20
Sup. 20 Exh. 20

The temperature display shows the temperatures of outdoor air, indoor air, supply air and exhaust air. The accuracy of the temperature sensors is $\pm 2^\circ\text{C}$.

2.6 Setting supply air temperature

Temp. setting
20C

Supply air temperature is changed with the + and – buttons.

3. Settings menu

You can move to the Settings menu from the Operating menu as described in Section 2.2. The displays of the Settings menu (Sections 3.1–3.29) can be scrolled with the scrolling buttons (see Section 1., items 5 and 6 in the figure).

3.1 Resetting maintenance reminder

Mainten. reset
Press + and –

The maintenance reminder is reset by pressing the + and – buttons simultaneously. This turns out the maintenance reminder symbol () in the main display.

3.2 Choosing maintenance reminder interval

Maintenance rem.
04

The interval for the maintenance reminder is selected with the + and – buttons. The maintenance reminder interval refers to months.

3.3 Choosing language version

Kieli / Language
English

The desired language is chosen with the + and – buttons.

3.4 Adjusting time

Adjust time
Press + and –

You can adjust time by simultaneously pressing the + and – buttons. See separate instructions in 4.2.

OPERATING INSTRUCTIONS FOR CONTROL PANEL

3.5 Week programme programming

Adjust wk. prog.
Press + and -

To go to the week-clock programme programming mode press the + and - buttons simultaneously. See the instructions in 4.1.

3.6 Erasing week programme

Erase wk. prog.
Press + and -

You can totally erase the week programme by pressing the + and - buttons simultaneously.

3.7 Choosing basic humidity level

Rh-level setting
automatic

The basic humidity level can be chosen as either automatic or manual. The selection is done with the + and - buttons.

3.8 Basic humidity level setpoint

Basic %RH level
40%

The desired setpoint is chosen with the + and - buttons when manual adjustment has been selected as the Rh level setting (humidity setting, Section 3.7).

3.9 Changing setpoint for carbon dioxide adjustment

CO2 setting
0900 PPM

The setpoint for CO₂ adjustment is chosen with the + and - buttons.

3.10 Adjustment interval

Adjust interval
10

The adjustment interval for humidity and carbon dioxide adjustments is selected with the + and - buttons. The adjustment interval refers to minutes.

3.11 Changing operating temperature of heat recovery cell bypass

Cell bypass
10C

The desired cell bypass temperature is selected with the + and - buttons. If outdoor temperature is lower than cell bypass temperature, the summer/winter damper is in the winter position.

3.12 Mode of operation of fireplace/booster switch

Switch type
fireplace switch

The mode of operation of the switch (either fireplace or booster switch) is selected with the + and - buttons.

3.13 Address of control panel

Panel address
1

The address of the control panel is changed with the + and - buttons. Two control panels cannot have the same address. If control panels have the same address, they go to bus fault state and do not work.

3.14 Contrast of control panel display

Display contrast
05

The contrast setting for the control panel display is changed with the + and - buttons.

3.15 Restoring factory settings

Factory settings
see manual

The general factory settings can be restored by pressing the + and - buttons simultaneously. Remember to ensure that the setpoints are in accordance with the factory settings for this unit.

3.16 Choosing cascade adjustment for supply air temperature

Cascade adjust
off

Cascade adjustment is chosen to be on or off with the + and - buttons.

3.17 Choosing post-heating for the unit

Radiator type
Electric rad.

A water or electric radiator is selected with the + and - buttons, depending on the type of post-heating radiator the unit is equipped with. Note! Choosing the wrong type of post-heating may cause a faulty post-heating function.

3.18 Choosing additional heater for unit

Extraheater type
Electric rad.

An electric or MLV radiator is chosen according to ventilation unit type with the + and - buttons. This unit can be used only for electric heater setting

3.19 MLV additional heater setpoint

MLV winter temp
0C

Changing MLV radiator setpoint. When outdoor air temperature goes below this setpoint, the ventilation unit starts the MLV pump. If a message "Preheating not in use" is displayed, no setpoint is in use.

3.20 Choosing melting mode

Defrost mode
fan stop

Choose one of the two modes of melting to be used in the unit. Melting is done either by stopping the supply air fan or by bypassing the HR cell. This setting must not be changed.

3.21 Winter parameter A

Winterparam. A
■ ■ ■ ■ ■ ■ ■ ■

The winter function of the unit is adjusted from the menu when it is not too cold outside (warmer than -1.5 °C). Decreasing the value of the parameter increases the freezing of the HR cell.

Increasing the value decreases the freezing of the HR cell. The unit operates optimally on the factory settings. There is no need to adjust this setpoint except in extreme problem situations, and even then it is advisable to contact Vallox Maintenance. The adjustment is made with the + and - buttons. See the table for the factory setting.

3.22 Winter parameter B

Winterparam. B
■ ■ ■ ■ ■ ■ ■ ■

The winter function of the unit is adjusted from the menu in very cold weather (colder than -1.5 °C). Increasing the value of the parameter increases the freezing of the HR cell.

Decreasing the value decreases the freezing of the HR cell. The unit operates optimally on the factory settings. There is no need to adjust this setpoint except in extreme problem situations, and even then it is advisable to contact Vallox Maintenance. The adjustment is made with the + and - buttons. See the table for the factory setting.

3.23 Setting base fan speed

MIN speed
1

The desired base fan speed (minimum fan speed) is chosen with the + and - buttons. Active when week-clock control is not on. Week-clock control changes this speed.

3.24 Choosing maximum fan speed

MAX speed
8

The desired maximum fan speed is selected with the + and - buttons. Maximum fan speed is on either with adjustments or always. See Section 3.25. Mode of operation of maximum speed setting.

3.25 Mode of operation of maximum speed setting

MAX speed limit
with adjustments

The maximum fan speed setting can be selected to be active either only in connection with (carbon dioxide and humidity) sensor adjustments or permanently. The selection is done with the + and - buttons.

3.26 Adjusting fan on the supply air side

DC fan, supply
100%

The desired adjustment value for the supply air fan is selected with the + and - buttons. The rotation speed of the supply air fan can be decreased by decreasing the percentage.

3.27 Adjusting fan on the extract air side

DC fan, exhaust
100%

The desired adjustment value for the extract air fan is selected with the + and - buttons.
The rotation speed of the extract air fan can be decreased by decreasing the percentage.

3.28 Fan speed level adjustment

Speed 1 level
15%

The desired fan speed level is adjusted from the menu. Adjustment range is 0-100%. However, fan speeds limit the adjustment range as follows:

If for instance speed 3 is 30%, speed 2 cannot be increased to more than 29% and speed 4 cannot be decreased below 31%.

The fan stops when the setpoint is 14% or lower. The adjustment is made with the + and - buttons. There are 8 displays, one for each fan step.

3.29 Moving to Operating menu

To Main menu
press + and -

To move back to the Operating menu, press the + and - buttons simultaneously.

4. Week-clock control

4.1 Week programme programming

The week programme can be used to set the desired fan speed (base fan speed) and supply air temperature for each hour of the day on seven days a week. The week programme overrides manual adjustments.

Carbon dioxide and humidity adjustment can increase fan speed but never decrease it below the base fan speed set in the week programme.

Example: Monday

It is the intention to decrease fan speed to speed 2 and supply air temperature to 17 °C between 07:00 (7 a.m.) and 16:00 (4 p.m.). After that, fan speed is raised to speed 4 and supply air temperature to 20 °C. For the evening, fan speed is boosted to speed 6 between 19:00 and 21:00 (7 p.m. and 9 p.m.), after which fan speed is lowered back to 4.

STARTING POINT

d	hr	sp	tmp	Exit
<u>1</u>	0	N	N	Exit
↑				
Cursor				
d	Day 1...7			
	1 = Monday, 2 = Tuesday etc.			
h	Hour 0...23			
sp.	Fan speed 1...8			
Temp	Supply air temperature			
	10...30°C			
Exit	Save the setting and exit			
N	No change to previous hour setting			

Move the cursor with the arrow keys and change values with the + and - buttons. Note that to exit and save when the programming is finished, move the cursor below the word Exit and press + or -.

Changes in fan speed (Sp.) and supply air temperature (Temp.) are only made for the hours desired; in other cases, use N (no change to previous).

d	hr	sp	tmp	Exit
<u>1</u>	7	2	17	Exit

Monday (d = 1), 07:00 (h = 7), fan speed 2 (sp = 2), supply air temperature 17 °C (tmp = 17).

Move the cursor to the following hour.

d	hr	sp	tmp	Exit
<u>1</u>	16	4	20	Exit

Monday (d = 1), 16:00 (h = 16), fan speed 4 (sp = 4), supply air temperature 20 °C (tmp = 20).

Move the cursor to the following hour.

d	hr	sp	tmp	Exit
<u>1</u>	19	6	N	Exit

Monday (d = 1), 19:00 (h = 19), fan speed 6 (sp = 6), supply air temperature no change (tmp = N).

Move the cursor to the following hour.

d	hr	sp	tmp	Exit
<u>1</u>	21	4	N	Exit

Monday (d = 1), 21:00 (h = 21), fan speed 4 (sp = 4), supply air temperature no change (tmp = N).

Move the cursor to the following hour.

Similar changes have to be made separately for each day. Finally, exit the programming mode by selecting Exit. If you wish, you can erase the week programme as indicated in Section 3.6. You can then start programming from the start. You can see the settings programmed by choosing a day and by scrolling the hours with the + or - button.

4.2 Adjusting time

day	hour	min	Exit
<u>1</u>	15	30	Exit
↑			

Cursor

D Day 1...7
1 = Monday, 2 = Tuesday etc.
H Hour, 0...23
M Minutes, 0...60
Exit Save the setting and exit

Move the cursor with the arrow keys and change values with the + and - buttons. Exit and save when the programming is finished.

Monday (D=1), hours 15 (H=15), minutes (M=30)

Time is maintained even though there is a power failure. (See Section 1.1, figure items 5 and 6).

5. Factory settings

Base fan speed	=	1
Maximum fan speed	=	8
Carbon dioxide adjustment (CO ₂)	=	900 ppm CO ₂
Adjustment interval	=	10 min
Winter parameter A	=	9 bars
Winter parameter B	=	3 bars
Mode of melting	=	stopping of fan
Maintenance reminder	=	4 months
Cell bypass	=	12 °C
Cascade adjustment	=	not in use
Speed steps:		
1.	=	31 %
2.	=	42 %
3.	=	47 %
4.	=	54 %
5.	=	59 %
6.	=	66 %
7.	=	72 %
8.	=	100 %
Humidity level (Rh level) setting	=	automatic
Switch type	=	fireplace switch
Extraheater type	=	electric radiator

This appliance can be used by children aged from 8 years and above and persons with reduced physical, sensory or mental capabilities or lack of experience and knowledge if they have been given supervision or instruction concerning use of the appliance in a safe way and understand the hazards involved.

Children shall not play with the appliance.

Cleaning and user maintenance shall not be made by children without supervision.

MAINTENANCE INSTRUCTIONS

MAINTENANCE

Before starting maintenance operations

When you open the VALLOX 110 SE unit, the security switch (S) turns voltage off. In spite of this, disconnect the plug of the unit. Disconnect the plug of the VALLOX 110 SE unit before starting maintenance operations.

Filters

When the maintenance reminder gives an alarm, the cleanliness of the filters must be checked. Outdoor air is filtered in the unit with two kinds of filters. A coarse filter (A) filters off insects, heavy pollen and other dust. An F7 class fine filter (B) filters off fine dust invisible to the eye. Extract air is filtered with a coarse filter (C).

By using original Vallox filters you ensure good operation of the ventilation unit and the best filtering result. The replacement interval of filters depends on dust content in ambient air. It is recommended to replace fans in spring and autumn, but at least once a year.

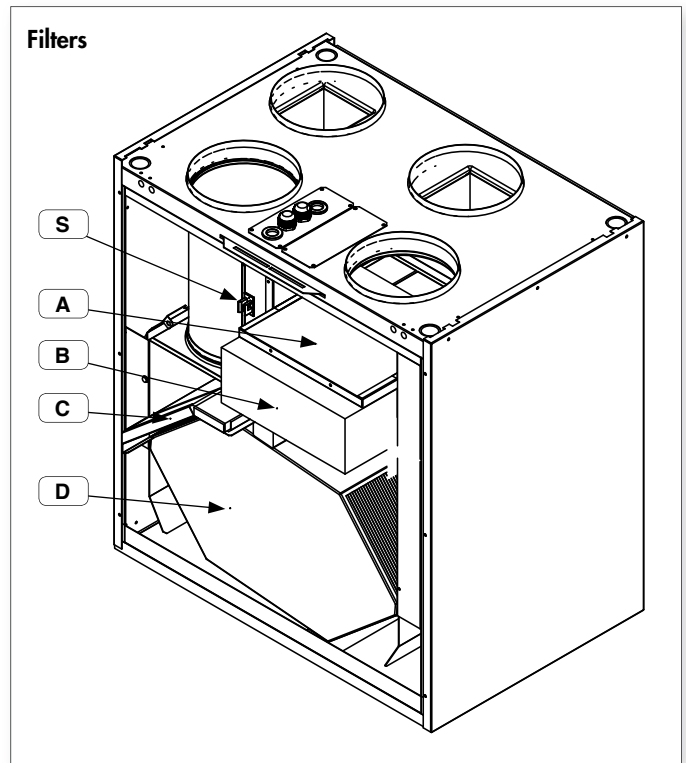

Heat recovery cell

When you replace the filters, you are also advised to check the cleanliness of the heat recovery (HR) cell (D) at an interval of approximately every two years. The sealing ledge (E) above the HR cell must be pulled off in the direction shown by the arrow in the figure. When the sealing ledge has been removed, the HR cell can be pulled out of the unit. Note! The laminas of the HR cell are very thin and get easily damaged.

If the HR cell is dirty, wash it by putting it in a solution of water with washing-up liquid. Rinse the HR cell clean with a jet of water. When water has drained from between the laminas, you can push the HR cell back in place. Finally, push the sealing ledge in place.

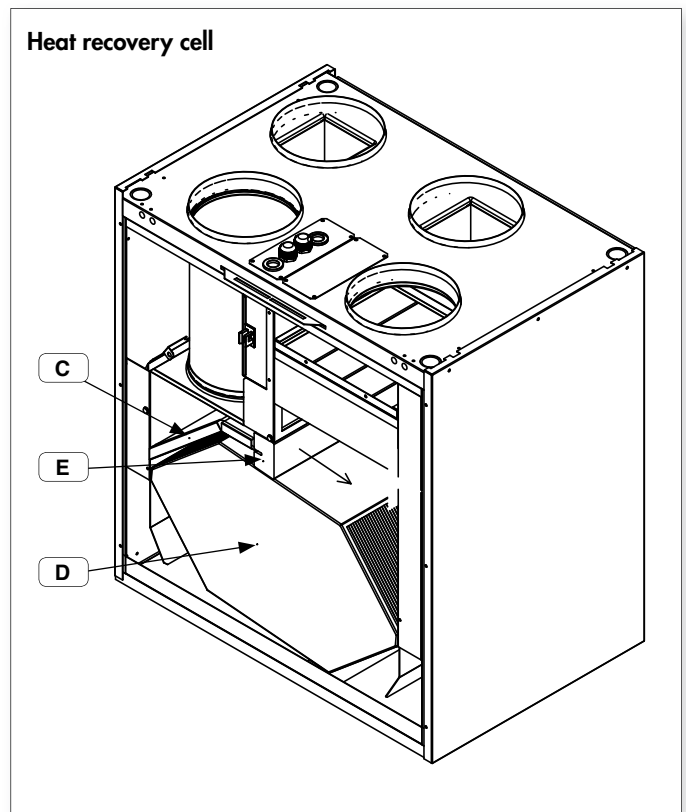

Fans

Check the cleanliness of the fans when carrying out maintenance for filters and the heat recovery cell. Clean the fans if needed. The fans are very sensitive to external mechanical damage, and it is recommended to clean them in place. The fan blades can be cleaned with compressed air or with a brush. Do not remove or move the balancing pieces on the fan blade.

Cleaning supply air fan (T)

Remove the HR cell (D) and the extract air filter (C) from the unit as instructed earlier. Pull off the temperature sensor (figures 1 and 2) from the upper part of the extract air duct (G). Then remove the extract air duct by turning and pressing it down simultaneously (figures 3 and 4). Remove next the support (H) for the additional and post-heating resistors. It is fastened with two butterfly nuts (I, figure 5) from below. Then pull the resistors and the support from the unit and disconnect the quick coupling of the resistor wires. The fan can now be cleaned in place. If you wish to remove the supply air fan, tear the adhesive tape supporting the fan (figure 6). The fan falls down and can be pulled out of the unit. Disconnect the quick coupling of the wires.

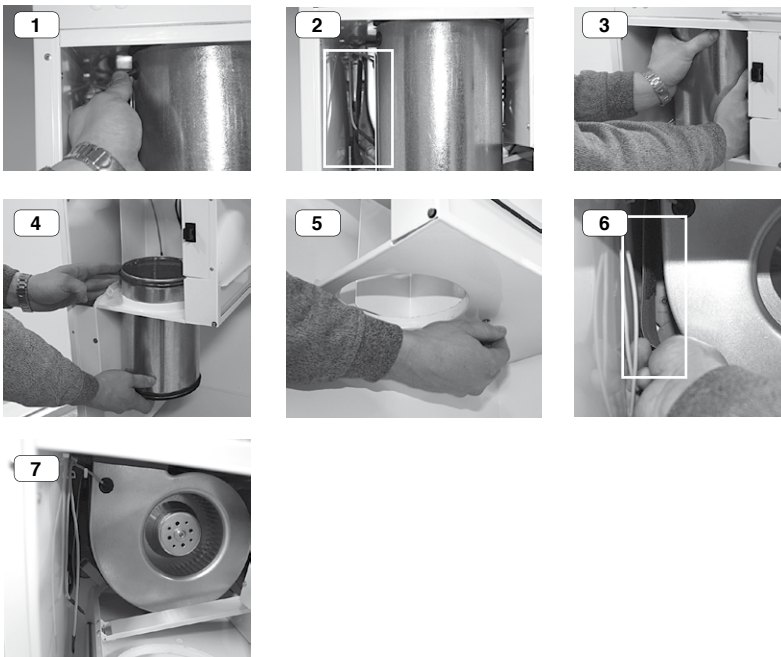

Cleaning extract air fan (P)

Remove the supply air filters G4 and F7. Open the four screws (F, figure 8) on the protective cover of the extract air fan and remove the cover. The extract air fan can now be cleaned in place (figure 9).

If you wish to remove the extract air fan, tear the adhesive tape supporting the fan. The fan falls down and can be pulled out of the unit (figure 10). Disconnect the quick coupling of the wires.

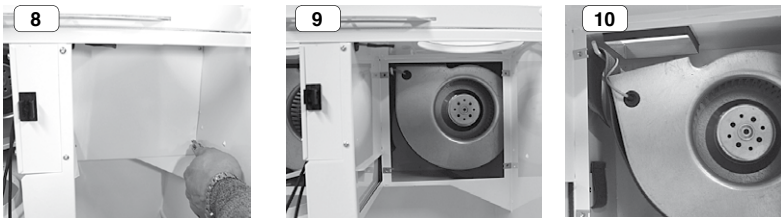

Condensing water

During the heating season, humidity of extract air condenses into condensing water. Water formation may be abundant in new buildings or if ventilation is low compared to the humidity build-up caused by the residents. Condensing water needs to flow out from the ventilation unit without hindrance. In carrying out maintenance, for instance in autumn before the beginning of the heating season, make sure that the condensing water outlet in the bottom tank is not clogged. You can check it by pouring a little water in the tank. Clean if needed. Do not let water flow into electrical devices.

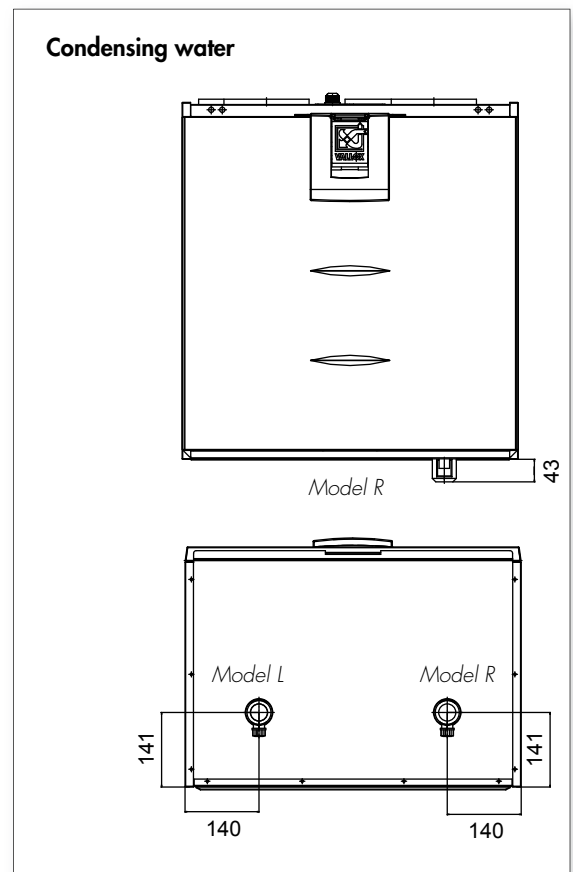
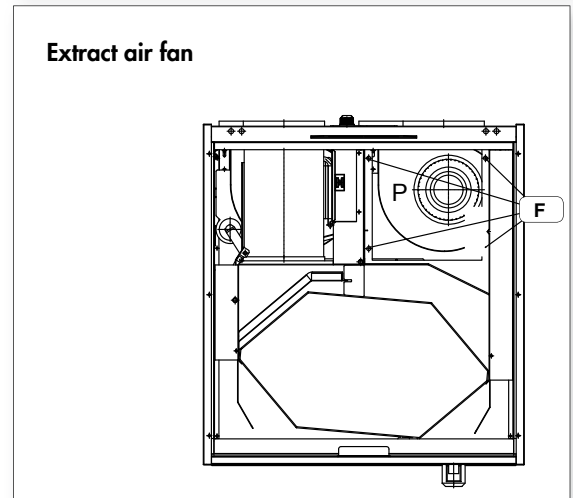
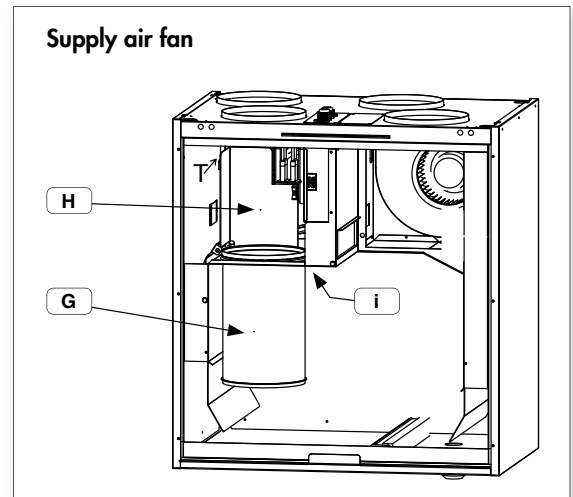

MAINTENANCE INSTRUCTIONS

Troubleshooting

Symptom	Cause	Do this
1 Outdoor air coming to the dwelling is cold.	<ul style="list-style-type: none"> Air cools down in the attic ducts. The heat recovery cell is frozen, which is why extract air cannot heat outdoor air. The post-heating radiator does not work. The extract air filter or cell is clogged. The initial adjustment of ventilation has not been done. 	<ul style="list-style-type: none"> Check the insulation of the attic ducts. Check the cleanliness of the filters and heat recovery cell.
2 The maintenance reminder symbol (M) is displayed and the unit operates otherwise normally.	<ul style="list-style-type: none"> The maintenance reminder lights up the maintenance reminder symbol in the main display of the control panel at an interval of circa 4 months (factory setting). You may change the interval (see the operating instructions for control panel, Section 3.2). 	<ul style="list-style-type: none"> Check the cleanliness of the filters and the unit. If needed, clean or replace the filters. Also check the external grille. Reset the maintenance reminder symbol (see the operating instructions for control panel, Section 3.1.).
3 "Exh air sensor faulty" message is displayed and the unit is stopped.	<ul style="list-style-type: none"> There is a fault in the freezing protection sensor. 	<ul style="list-style-type: none"> Contact a maintenance company. Sensor mounting needs to be checked and the sensor has to be replaced if necessary.
4 "Sup. air sensor faulty" message is displayed and the unit is stopped.	<ul style="list-style-type: none"> There is a fault in the supply air sensor. 	<ul style="list-style-type: none"> Contact a maintenance company. Sensor mounting needs to be checked and the sensor has to be replaced if necessary.
5 "Ind. air sensor faulty" message is displayed and the unit is stopped.	<ul style="list-style-type: none"> There is a fault in the extract air sensor. 	<ul style="list-style-type: none"> Contact a maintenance company. Sensor mounting needs to be checked and the sensor has to be replaced if necessary.
6 "Out. air sensor faulty" message is displayed and the unit is stopped.	<ul style="list-style-type: none"> There is a fault in the outdoor air sensor. 	<ul style="list-style-type: none"> Contact a maintenance company. Sensor mounting needs to be checked and the sensor has to be replaced if necessary.
7 "Cell sensor faulty" message is displayed and the unit is stopped.	<ul style="list-style-type: none"> There is a fault in the sensor of the heat recovery cell. 	<ul style="list-style-type: none"> Contact a maintenance company. Sensor mounting needs to be checked and corrected if necessary.
8 "Bus fault" message is displayed and the unit operates at speed 1 (check the fan speed).	<ul style="list-style-type: none"> Wiring fault in the carbon dioxide sensor, in the control panel or in the humidity sensor, or the cable is of the wrong type. 	<ul style="list-style-type: none"> Contact a maintenance company. The connections have to be checked and corrected if necessary.
9 "Freezing alert" message is displayed and the unit is stopped.	<ul style="list-style-type: none"> Antifreeze of the water-circulating radiator is active. <p>NOTE! If there is no non-freezing solution in the water of the radiator, the radiator is at risk of freezing. (Does not apply to the Vallox 110 SE unit)</p>	<ul style="list-style-type: none"> Immediately troubleshoot the situation. Consult a maintenance company to find out if there is any non-freezing solution in the radiator. Check if the circulation pump is broken, the boiler out of operation etc. The situation may pass by itself as soon as supply air temperature exceeds 10 degrees, but do not wait till it happens.
10 The desired automatic adjustment does not stay on.	<ul style="list-style-type: none"> There is a fault in the humidity or carbon dioxide sensor. One of the sensors is broken or missing. 	<ul style="list-style-type: none"> Contact a maintenance company. Sensor mounting and connections have to be checked. (Sensors are options.)
11 The fans are not running and no indicator light is lit at the control panel.	<ul style="list-style-type: none"> Door switch may be broken or the door is not quite closed. The unit is out of power, for instance because a fuse has blown. The glass tube fuse (located in the control card behind a protecting plate) protecting the electronics inside the unit may have blown. 	<ul style="list-style-type: none"> Check the door switch and fuses. The unit has a T800 mA glass-tube fuse. If needed, contact a maintenance company (for instance to check the glass tube fuse).
12 The unit does not obey the control panel.		<ul style="list-style-type: none"> Disconnect the plug of the unit from the wall socket, wait for 30 seconds and put the plug back. If this does not help, contact a maintenance company.
13 "Carbon dioxide alarm" message is displayed and the unit is stopped.	<ul style="list-style-type: none"> Carbon dioxide alarm. Carbon dioxide content has exceeded 5000 PPM for two minutes. May be caused by for instance a fire. 	<ul style="list-style-type: none"> If there is a fire, take the necessary steps. You can make the unit operational by disconnecting the plug from the wall socket, waiting for 30 seconds and putting the plug back.
14 Filter guard symbol (F) is displayed and the unit operates otherwise normally.	<ul style="list-style-type: none"> The pressure in the filter guard (pressure difference switch) has risen above the adjustment value or speed is 7 or 8 (option). 	<ul style="list-style-type: none"> Check the cleanliness of the filters and the unit. If needed, clean or replace the filters. Also check the external grille.

Dimensions and duct outlets

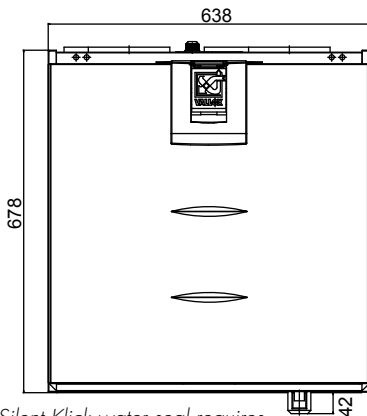

Vallox Silent Klick water seal requires a space of 70 mm for installation.

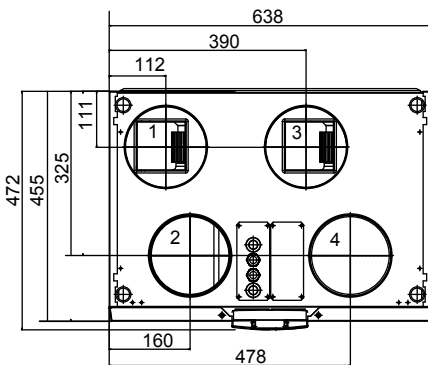

Duct outlets, model R

Inner diameter of female outlet collar \varnothing 160 mm

1. Supply air to the dwelling
2. Extract air from the dwelling to the unit
3. Exhaust air out
4. Outdoor air to unit

Duct outlets, model L

Inner diameter of female outlet collar \varnothing 160 mm

1. Exhaust air out
2. Outdoor air to unit
3. Supply air to the dwelling
4. Extract air from the dwelling to the unit

Location of condensing water outlets, R and L models

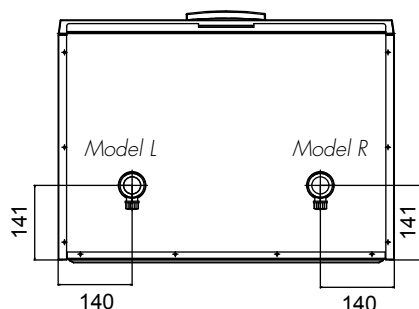

Measuring points

Measuring points after the connection outlet. Fan curves indicate the total pressure available for duct losses.

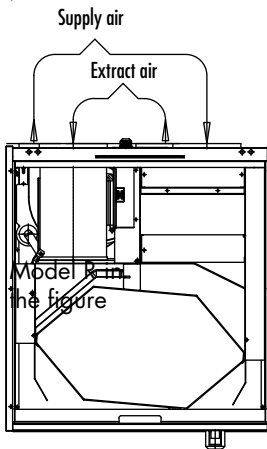

Fan input power

Fan speeds	Extract air flow (l/s)	Fan input power W
1	28	21
2	35	32
3	46	44
4	59	63
5	71	82
6	78	110
7	83	137
8	106	224

Supply/extract air flows

P = Extract air fan
T = Supply air fan

$$SFP = \frac{\text{Input power (total) (W)}}{\text{Air flow (max.) (dm}^3\text{/s)}}$$

SFP (Specific Fan Power) recommended value < 2.5 (kW m³/s)
At a lower total pressure, SFP will be smaller at this speed.

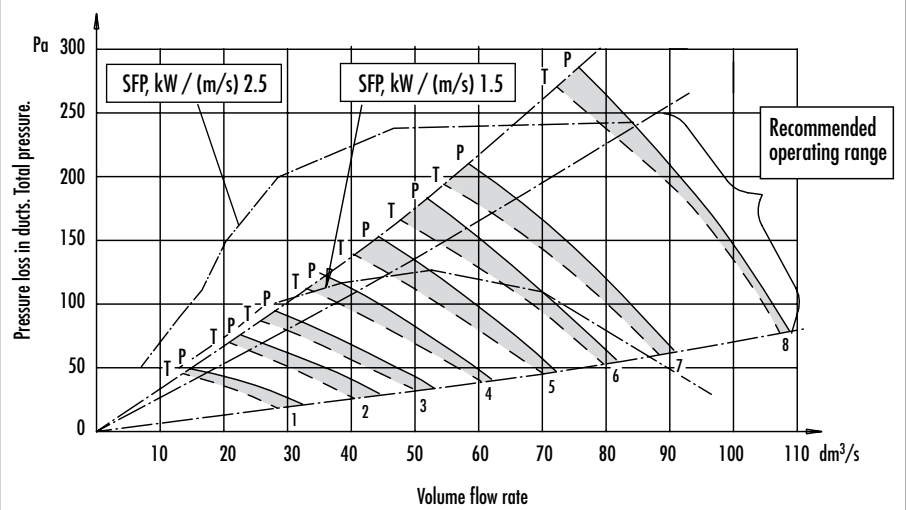

Sound values

Adjustment position Air flow dm ³ /s	Sound power level in supply air duct (one duct) by octave band L _w dB								Sound power level in extract air duct (one duct) by octave band L _w dB							
	ADJUSTMENT POSITION/AIR FLOW dm ³ /s								ADJUSTMENT POSITION/AIR FLOW dm ³ /s							
	1	2	3	4	5	6	7	8	1	2	3	4	5	6	7	8
Medium frequency of the octave band Hz	25.7	41.5	51.0	53.9	58.8	75.6	78.8	101.0	29.5	41.3	43.8	51.9	60.8	70.7	75.3	96.0
63	63	69	73	76	77	80	82	83	45	52	58	61	63	66	68	72
125	55	60	63	67	70	71	74	78	46	51	54	57	60	62	64	69
250	42	49	52	55	57	61	63	67	33	40	43	47	49	51	53	58
500	45	51	53	55	58	60	62	67	32	36	38	41	44	47	48	52
1000	42	49	52	54	56	59	60	63	25	30	33	35	38	40	41	45
2000	36	44	49	52	55	59	60	65	13	21	24	28	31	34	36	40
4000	23	34	39	42	45	49	51	56	*	*	10	13	17	21	23	28
8000	*	25	31	36	40	44	47	53	*	*	*	*	*	*	*	16
L _w dB	64	70	73	77	78	80	83	85	49	55	60	63	65	68	70	74
L _w dB(A)	47	53	57	59	62	65	66	71	35	40	42	46	48	50	52	57
Sound pressure level dB (A) coming from the unit through the envelope in the rooms where the unit has been installed (10m ² sound absorption)																
ADJUSTMENT POSITION/AIR FLOW dm ³ /s																
1 2 3 4 5 6 7 8																
30/30 41/41 49/47 55/55 64/63 72/71 80/78 100/96																
L _p dB (A)	26	31	34	36	39	41	43	47								

Vallox 110 SE

Internal electrical connection Vallox 110 SE (code 3700)

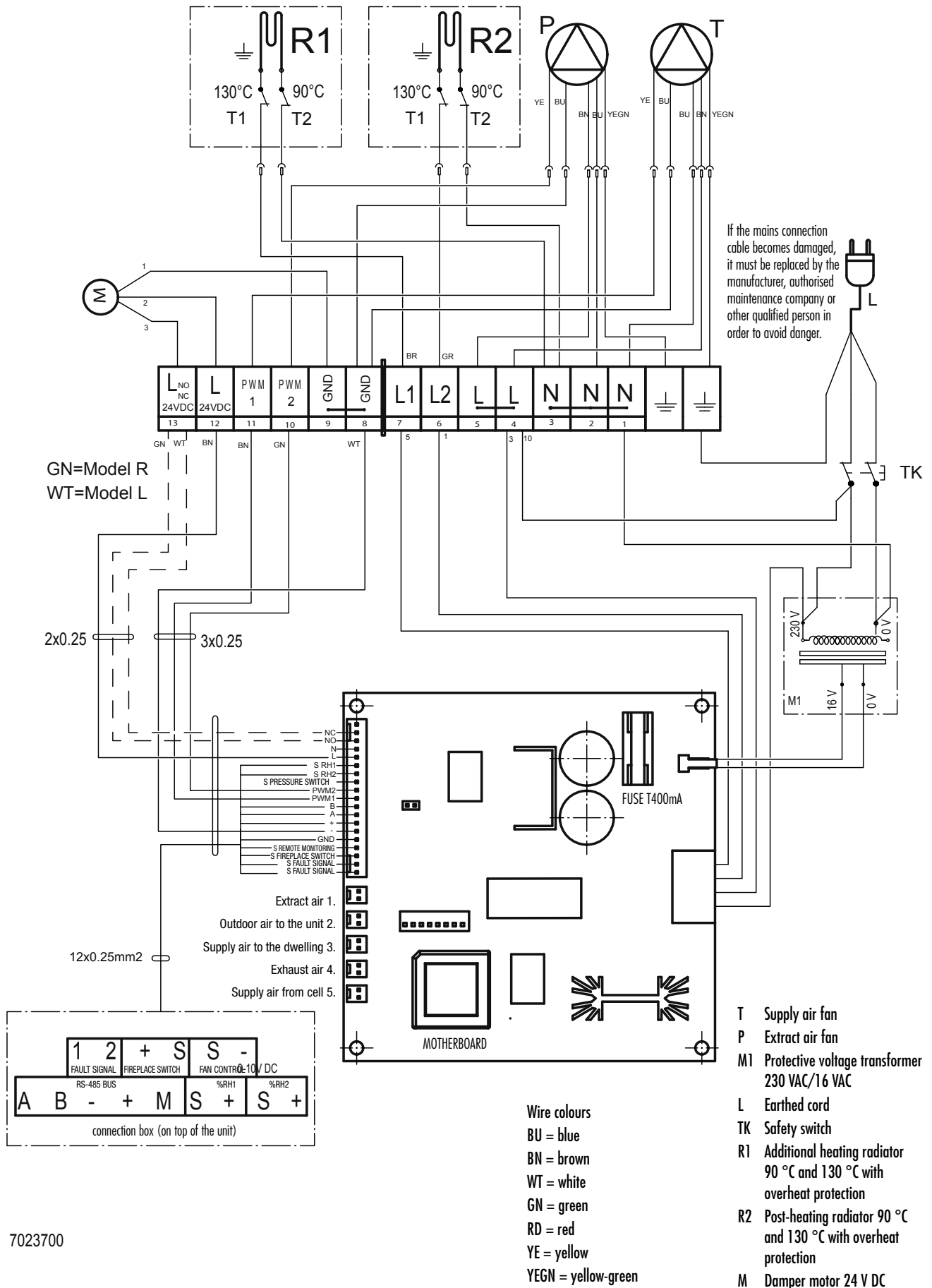

7023700

External electrical connection Vallox 110 SE (code 3700)

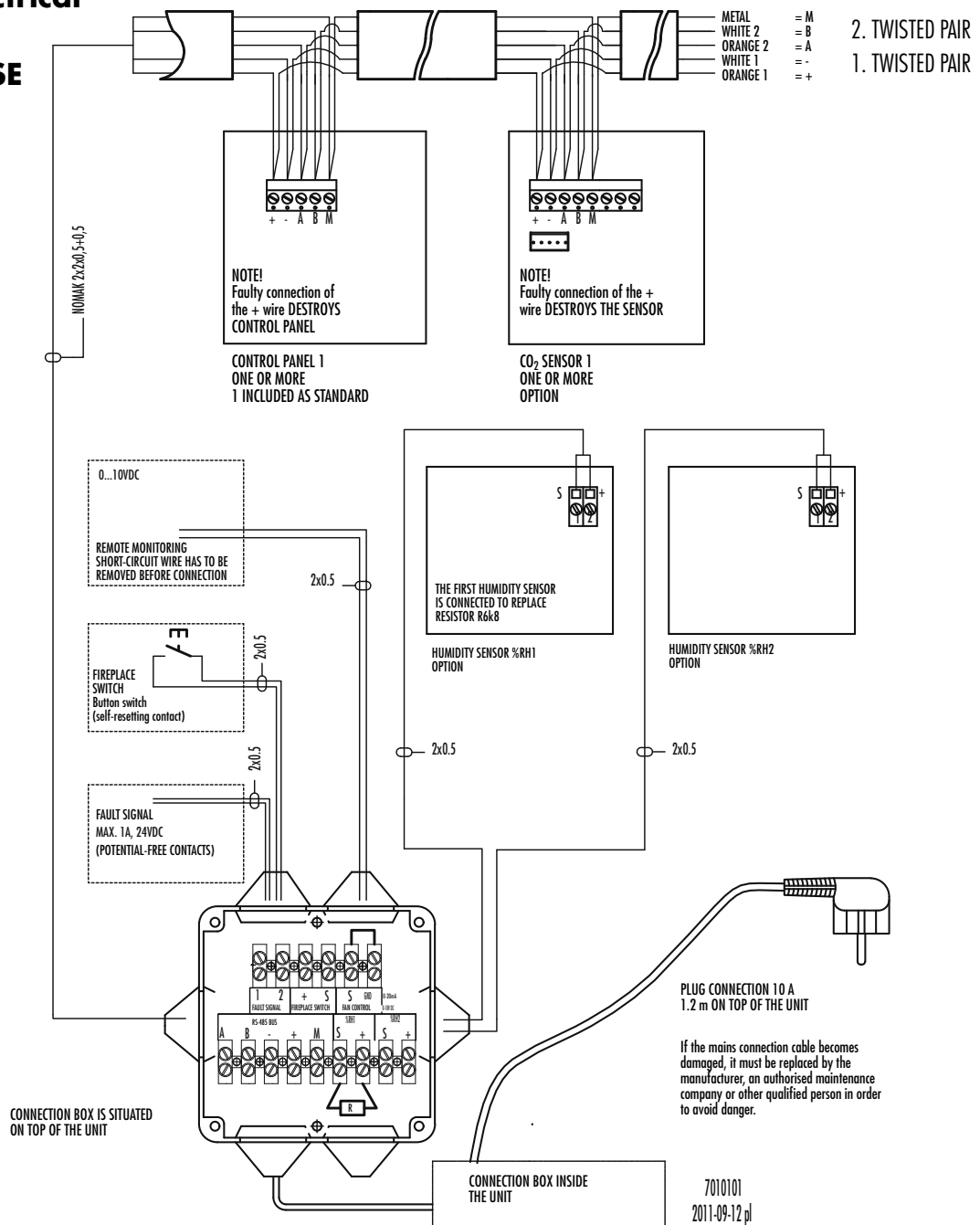

Mounting, removing and wiring of the control panel

The control panel is wired straight from the electrical connection box. The control panel can also be connected in series with a CO₂ sensor or another control panel. (See External electrical connection).

Control panel addresses

If two or more control panels are connected to the system, the addresses of the control panels need to be changed.

For example 3 control panels

- Connect the first control panel to the unit and change its address to 3.
- Connect the second control panel to the unit and change its address to 2.
- Connect the third control panel and make sure that its address is 1.

If control panels have the same address, they go to bus fault state. In this case, remove one of the control panels and change the address of the other panel. The above mentioned situation can arise in connection with the later installation of an additional control panel.

Width 90 mm
Height 110 mm
Depth 23 mm

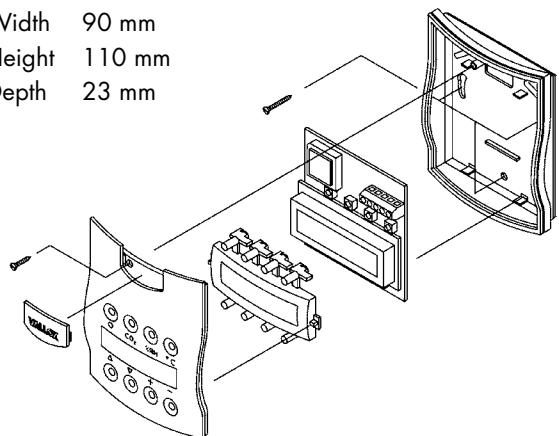

MOUNTING

Mounting

VALLOX 110 SE has to be mounted in a place where temperature does not go below +10 °C. Without protective enclosure, the unit must be located in a place with no acoustic disturbance: storerooms, technical rooms etc.

Wall mounting

VALLOX 110 SE is mounted on the wall with a mounting plate as shown in the adjacent figure. Make sure that the unit is horizontally level after mounting.

Wall construction

Observe the wall construction during mounting. Avoid mounting the unit on a hollow, echoing dividing wall and on a bedroom wall because of sound conduction, or prevent sound conduction.

Condensing water connections

The delivery includes a water seal. By connecting a pipe to the water seal the water condensing from extract air can be led to a floor drain (not directly to the drain). The pipe must not rise after the water seal. The unit has to be mounted horizontally level, so that condensing water can get freely out of the unit.

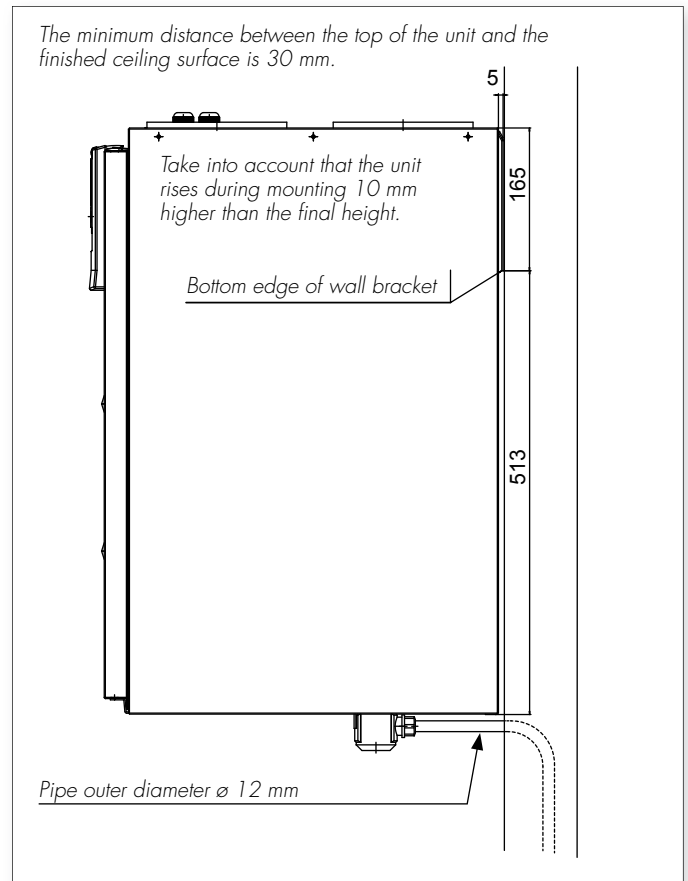

Ceiling mounting with ceiling mounting plate (option)

An optional ceiling mounting plate can be used with the unit. The ceiling mounting plate is attached to the ceiling with M8 thread bars. Fix the bars so that they stand the weight of the unit. The ceiling mounting plate has to be fixed horizontally in order to ensure that the unit will be straight. The outdoor and exhaust air duct must be insulated against condensation, also between the unit and the ceiling mounting plate. The ceiling mounting plate is mounted horizontally level, and it has to be attached so that there is a space of circa 8 mm between the back edge of the ceiling mounting plate and the wall. The ventilation unit is then as close to the wall as possible. Minimum distance between the bottom edge of the ceiling mounting plate and the ceiling of the room is 50 mm.

The ceiling mounting plate is fixed to the ceiling with M8 thread bars. After the thread bars have been fastened to the ceiling, first turn the nuts into the thread bars and lift the ceiling mounting plate in

place. Then push a rubber damper and washer to each thread bar, all the way into the cup of the plate, and turn the nut. Shorten the lower ends of the thread bars so that they will be at no more than 25 mm from the lower surface of the ceiling mounting plate.

Mounting of ventilation unit to ceiling mounting plate

Mount the locking washers (J) delivered with the ceiling mounting plate in place with the 4 screws. Lift the unit and take the connection box and the control panel through the opening in the ceiling mounting plate. Put the locking devices attached to the top of the ventilation unit at the openings in the ceiling mounting plate and lift upwards. Make sure that the unit is locked in place.

Check that the condensing water insulation between the unit and the ceiling mounting plate is in place in the exhaust and outdoor air duct. The unit can be detached from the ceiling mounting plate by pulling the spring-loaded moulding to the direction shown by the arrow (more detailed information provided with the ceiling mounting plate).

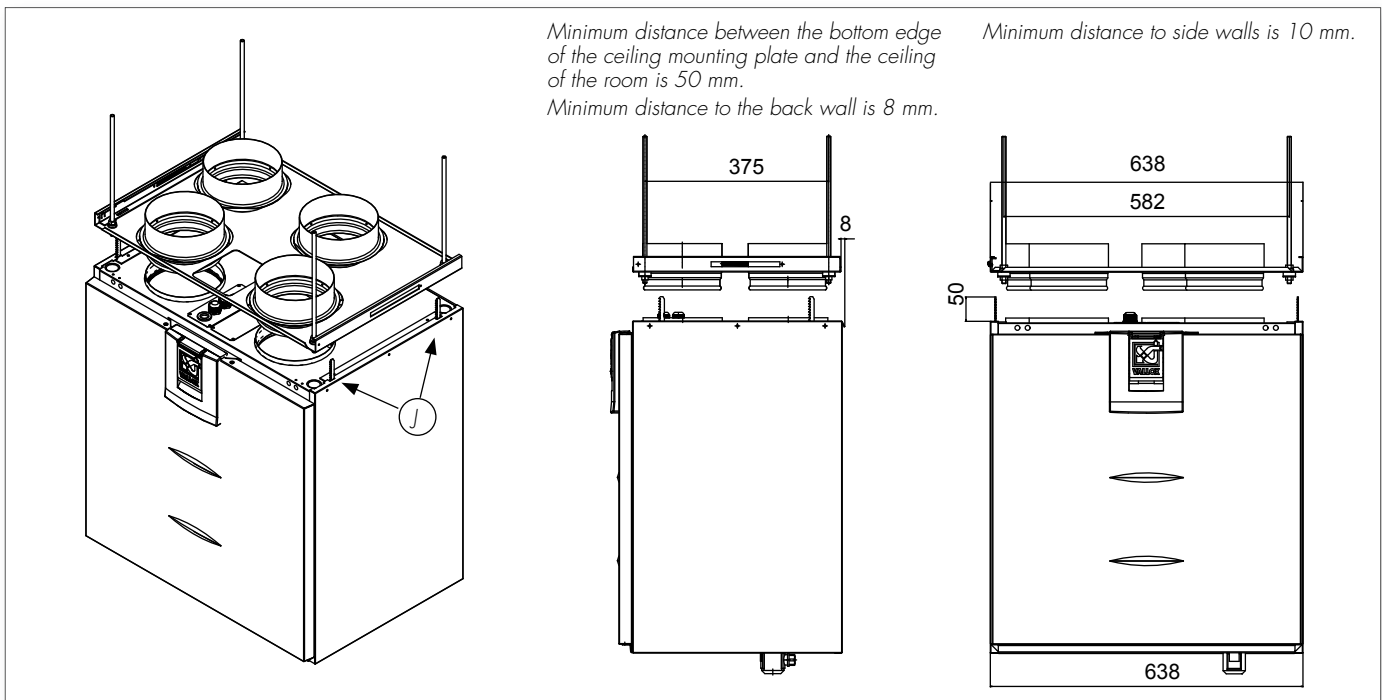

Attic floor penetration plate (option)

When an attic floor penetration plate is used, the tightness of the vapour barrier has to be ensured.

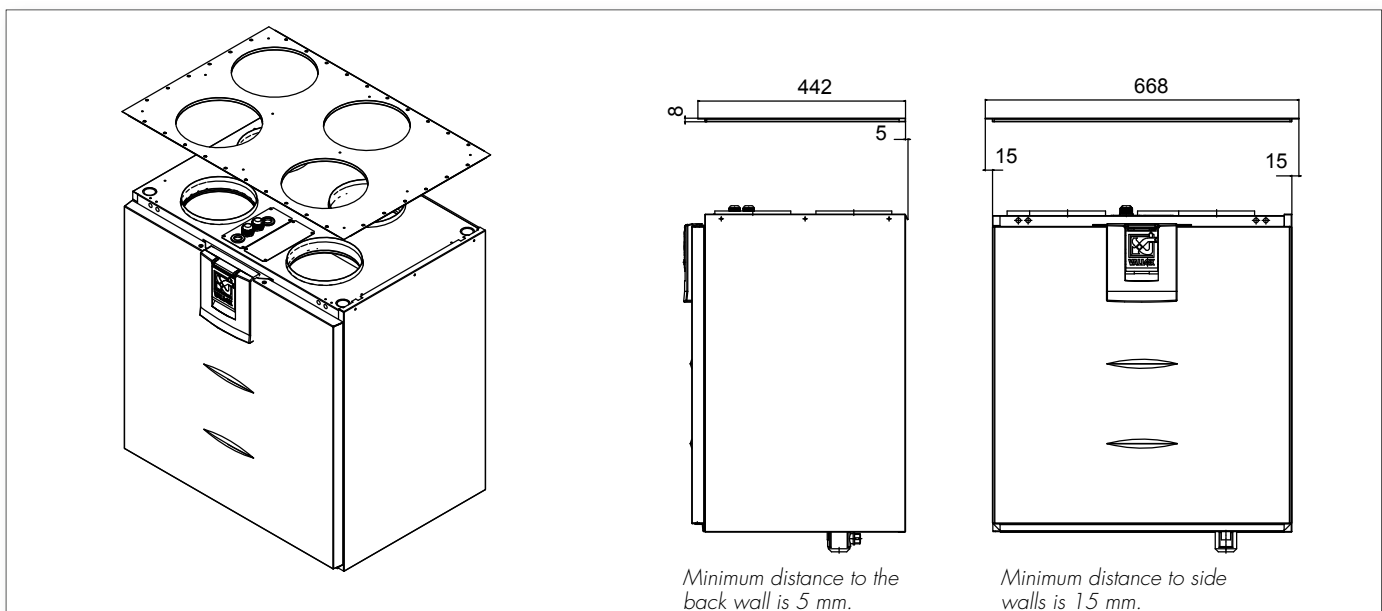

Exploded view and parts list VALLOX 110 SE (code 3700)

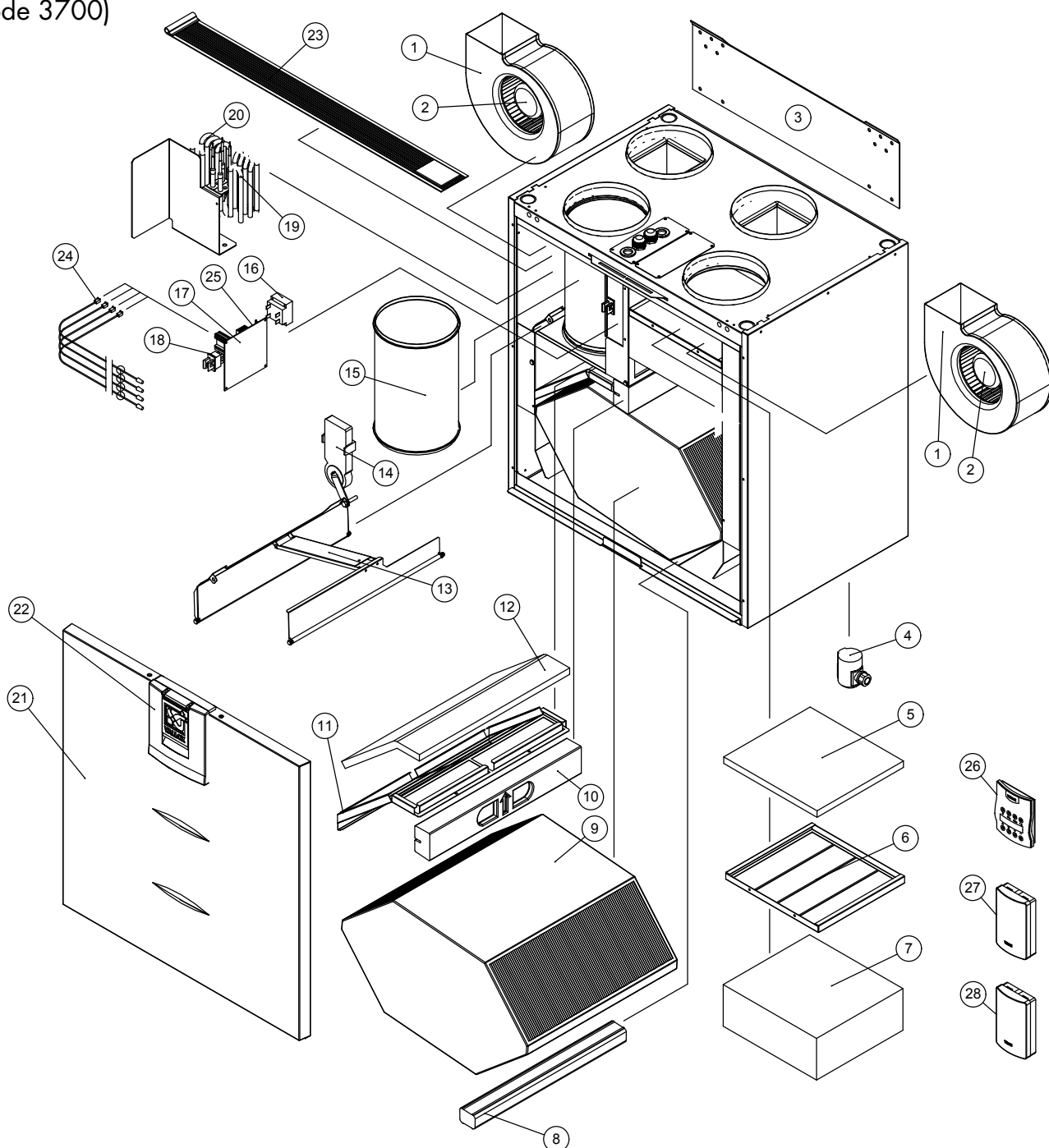

No. Part	Code	No. Part	Code	No. Part	Code
1 Fan assembly	1106100	13 Bypass duct assembly, handedness must be indicated	3447200	22 Door latch assembly	3355900
2 Fan motor	935360	14 Damper motor	930613	23 Adhesive tape	3442300
3 Wall mounting plate	3080700	15 Extract air outlet	985025	24 NTC sensor, sensor number must be indicated	946140
4 Water seal	3292500	16 Protective voltage transformer	940150	25 Glass tube fuse 5x20 0.4 A slow	952485
5 G4 coarse filter	978042	17 Motherboard	949045	26 Control panel	3214000
6 Filter stand	3454000	18 Safety switch	948370	27 Humidity sensor (option)	946142
7 F7 filter	978157	19 Additional heater	942211	28 Carbon dioxide sensor (option)	946146
8 Lower support for HR cell	3450100	20 Post-heater	942210		
9 HR cell	933160	21 Door assembly	3447300		
10 Upper support for HR cell	3426600				
11 Filter stand	3426800				
12 G4 coarse filter	978043				

