

印刷制作说明 (非印刷页)

叶子类目	手推行车
厂家型号	0.5T-H
子 SKU	GZLXCDDHLXC1ITPH9001V0
厂家型号	1T-H
子 SKU	GZLXCDDHLXC10P875001V0

技术要求:

- 1.内容正确，图文清晰，位置准确；
- 2.成品不准有破损、裂纹污迹等影响美观缺陷；
- 3.具体页数、尺寸、内容、字体、字号、按设计图纸；
- 4.A5 版面双面黑白印刷，80g 以上铜版纸或者双胶纸。
- 5.装订方式骑马订/折页或者胶装。
- 6.打样确认后方可批量印制。

VEVOR

Upgrade · The Home Creator Way

Monorail Trolley

Model: 0.5T-H, 1T-H

VEVOR Support Center



0.5T-H



1T-H

Model:0.5T-H, 1T-H



This is the original instruction, please read all manual instructions carefully before operating. VEVOR reserves a clear interpretation of our user manual. The appearance of the product shall be subject to the product you received. Please forgive us that we won't inform you again if there are any technology or software updates on our product.



Warning-To reduce the risk of injury, user must read instructions manual carefully.

SAFETY INSTRUCTIONS

- 1.Warning-To reduce the risk of injury, user must read instructions manual carefully.
- 2.The product complies with relevant standards and regulations. Installation of this device must comply with all applicable regulations, and it should only be operated in well-ventilated areas. Please read the user manual before installing and using this equipment.
- 3.This appliance is not intended for use by persons (including children) with reduced physical, sensory or mental capabilities, or lack of experience and knowledge, unless they have been given supervision or instruction concerning use of the appliance by a person responsible for their safety.
- 4.Children shall not play with the appliance.
- 5.This appliance shall not be used by children. Keep the appliance and its cord out of reach of children.
- 6.Manual trolleys are versatile material handling devices designed to traverse a load along the bottom flange of an overhead I-beam or rail. Their primary function is to convert a stationary hoist into a movable lifting system. General Industry Standard (ASME): In North America, the ASME HST-2 standard specifies that manually operated chain hoists and trolleys are intended for industrial use in ambient temperatures from 0 °F to 130 °F (-20 °C to +50 °C.)
- 7.Please properly keep product. Check whether the product is abnormal before use. If it is abnormal, please stop using it.
- 8.Please use the product according to the intended use, warn of potential injury from misuse.

SAVE THESE INSTRUCTIONS

Installation of trolley onto beam

(1) The preferred method of installation is from the end of the beam, with the chain hoist and the trolley coupled. After installation, check that all the nuts are correctly tightened. Fit the travel limit stops (not provided) at the end of the runway.

(2) When there is no space between the end of the beam and building, first remove the side plate from the suspension shaft. After placing the side plate on the other side of the flange, reassemble and reinstall side plate as it was before. Also, bend securely the split pin of the shaft stopper pin. After installation, check that all the nuts are correctly tightened.

Safety Inspection

(1) The danger exists when heavy loads are transported, particularly when the equipment is not being used properly or is poorly maintained. Because accidents and serious injury could result, special safety precautions apply to the operation, maintenance. The hoist may lift and hold a load more than the rated loads. Check that structure for mounting the trolley has sufficient strength.

(2) Check that the correct Trolley and the capacity of lifting equipment attached to the Trolley are suitable for the job at hand. Visually check that the Trolley has been delivered and/or stored in a safe and undamaged condition.

(3) Slacken off the suspension pin nuts & spread the side plates so that the wheels can be slipped over the runway beam. Screw the nuts firmly against the washers. Then suspend a light load to the trolley to ensure that all four wheels contact the runway beam. Screw the nuts tightly against the washers, then secure them with lockouts. **NUTS MUST BE TIGHT.**

(4) Suspend the Maximum Safe Working Load to the trolley, and then run the unit slowly along the full length of the runway beam to ensure satisfactory operation. Once the unit is fitted - check that the clearance between the beam's outer edge and the trolley wheel is equal on both sides. Also, check that the Beam End Stops have been fitted to the beam.

(5) Ensure that the load bar has been assembled correctly. The Loadbar should also be checked for wear, defects, and deformations, or superficial/corrosion marks before every use.

Intended purpose

This trolley is designed for horizontally transporting loads by hand, through an electric hoist under normal atmospheric conditions of the workplace. The 1100lbs trolley is suitable for a PA200-PA500 electric hoist. The 2200lbs trolley matches the needs of the job for the PA600-PA1000 electric hoist.

Main structure

1. Side Locking Nut
2. Trolley Pin
3. Side Plate
4. Steel Wheel
5. Casing Gaskets
6. Bracket
7. Mounting Hole

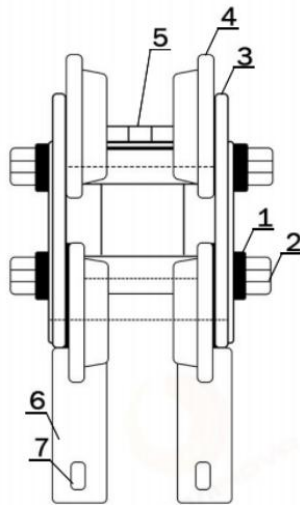

MAINTENANCE

MODEL	0.5T-H	1T-H
CAPACITIES/lbs	1100	2200
Adjust range	2.68-4.33inch	
Color	Orange	

When the trolley and the hoist are coupled, the trolley must be adjusted with the adjusting spacers. Assemble the required number of spacer washers equally to the inside of the trolley side plates so that the dimension between the Trolley Wheel Flanges is about 1/4inch (6mm) greater than the runway beam width. Then assemble the nuts to the suspension pin.

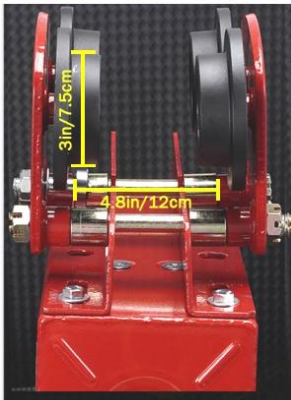

MAINTENANCE

1. Avoid prolonged exposure to the sun to avoid aging.

