

Installation Instructions

OpenTherm

Input Module 0-10V, Part No. 7249 069

for use with Vitodens 100, WB1A series boilers, WB1B CombiPLUS series boilers, B1HA and B1KA series boiler

Please file in Service Binder

Safety and Installation Requirements

Please ensure that these instructions are read and understood before installation. Failure to comply with the instructions listed below can cause **product/property damage, severe personal injury, and/or loss of life.**

Working on the equipment

The installation, adjustment, service and maintenance of this product must be done by a **licensed professional heating contractor** who is qualified and experienced in the installation, service, and maintenance of hot water boilers. There are no user serviceable parts on the boiler, burner or control.

Ensure **main power** supply to equipment, the heating system, and all external controls has been **deactivated. Close main gas supply valve.** Take precautions in both instances to avoid accidental activation of power during service work.

It is not permissible to perform service work on any component part ensuring safe operation of the heating system. When replacing parts, use original Viessmann or Viessmann approved replacement parts.



Ensure that the installation literature of other Vitodens 100, components is referenced.

Input Module Description

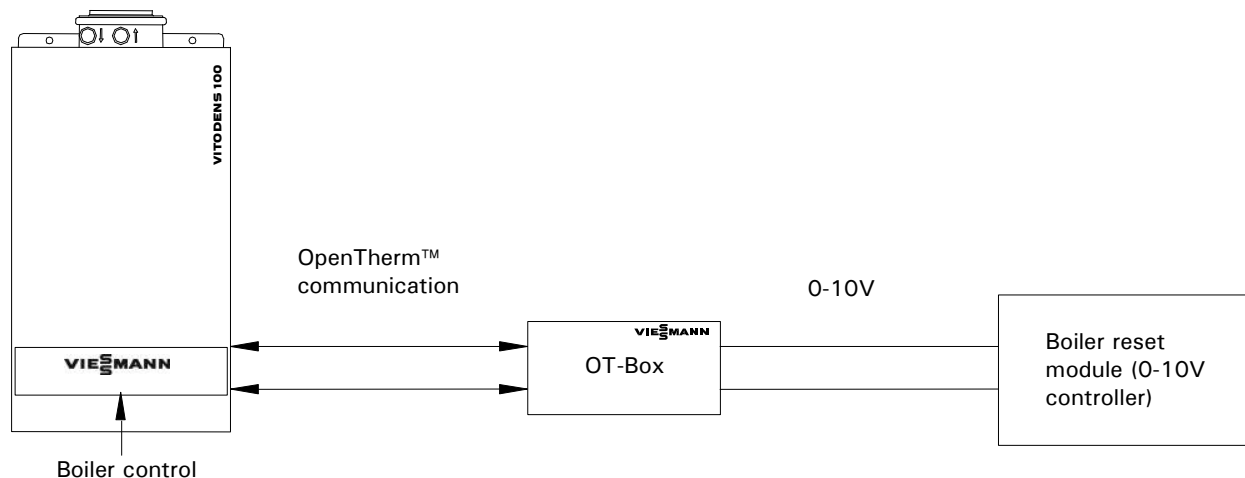

Fig. 1
OpenTherm communication system

What is OpenTherm™

The OpenTherm (OT) protocol is a point-to-point communication system, which connects a boiler with a room controller. The room unit calculates a heating demand (water temperature request) and transmits it to the boiler. The boiler will adjust the heat input accordingly (low-high modulation).

The Viessmann Input Module is designed to accept a 0-10V (DC) modulating input signal from a boiler reset module controller and send this signal to the Vitodens 100 with OpenTherm communication. *See the chart on the following page for signal translation protocol of 0-10V to boiler approximate supply temperature.*

Input Module Operating Characteristics

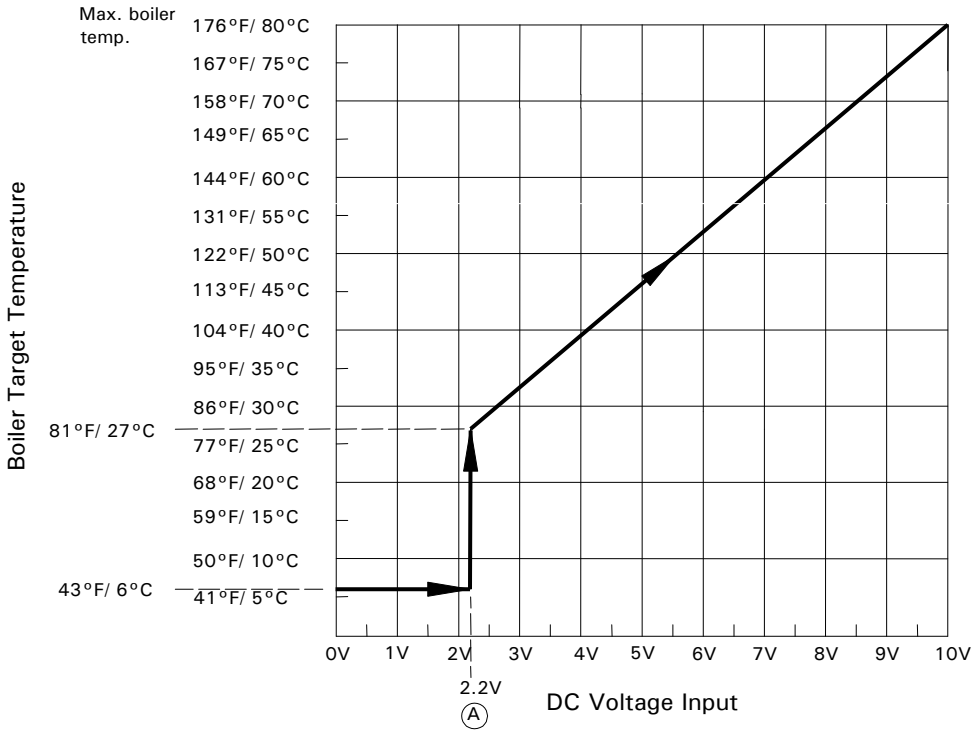

(A) Lowest voltage signal (from below 0.9 V) to start boiler (cut-in) = 2.2 V

(B) Lowest voltage signal to shut down (cut-out) the boiler = 0.9 V

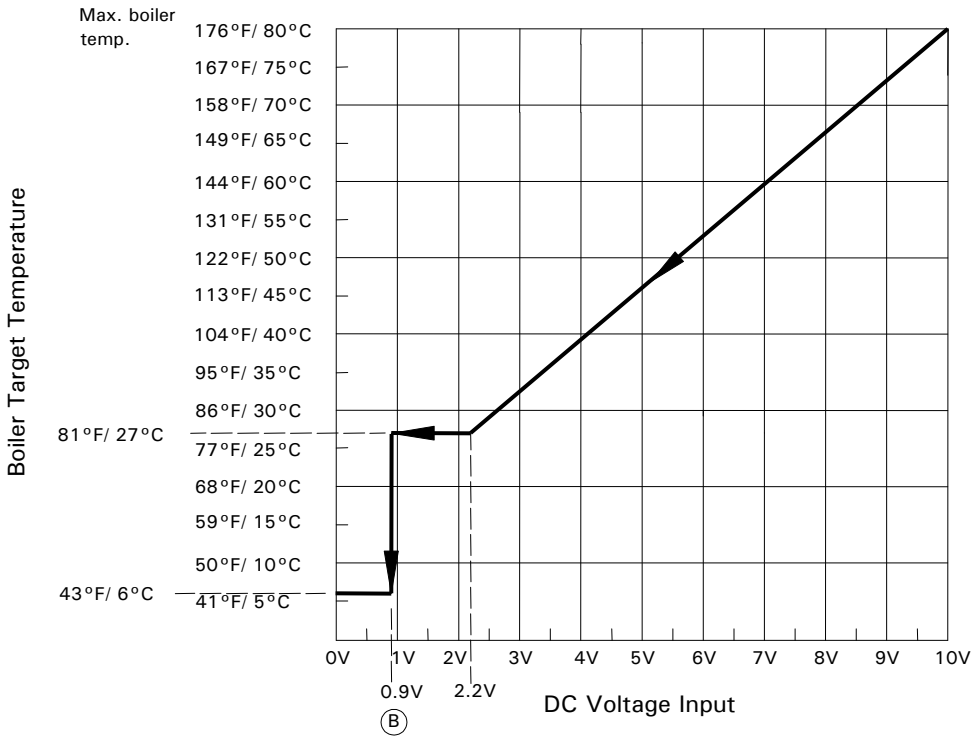

The voltage signal must fall below 0.9VDC ($V \leq 0.9$) in order for the Input Module to reset temperature setpoint from 81°F/ 27°C to 43°F/ 6°C. Any voltage signal between 0.9 to 2.2 V will maintain a supply temperature of 81°F/ 27°C.

Boiler cycles ON/OFF based on the fixed differential settings of the boiler control module.

Fig. 2
Input Module voltage – temperature translation chart

Installation



Fig. 3
Input Module base with closed terminal cover

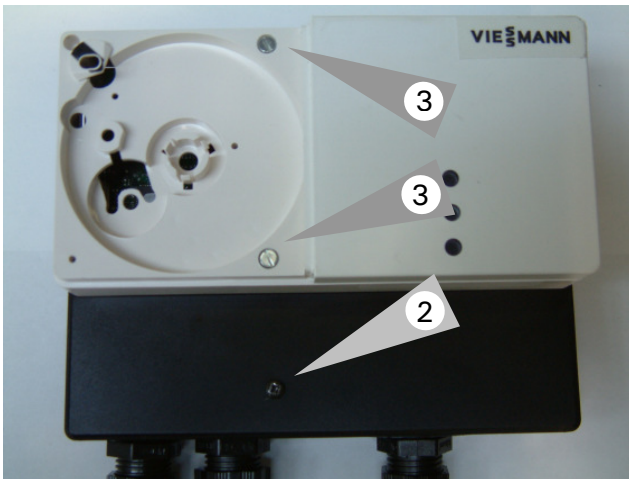

Fig. 4
Input Module with left cover open



Fig. 5
Input Module with the module pulled off from its sub-base

1. Remove left white cover of the Input Module.

2. Remove black cover of the Input Module.

3. Loosen two screws and gently pull the module off its sub-base.

4. Remove required number of knockouts. Install supplied strain reliefs and guide wire harness into the terminal box.

Installation

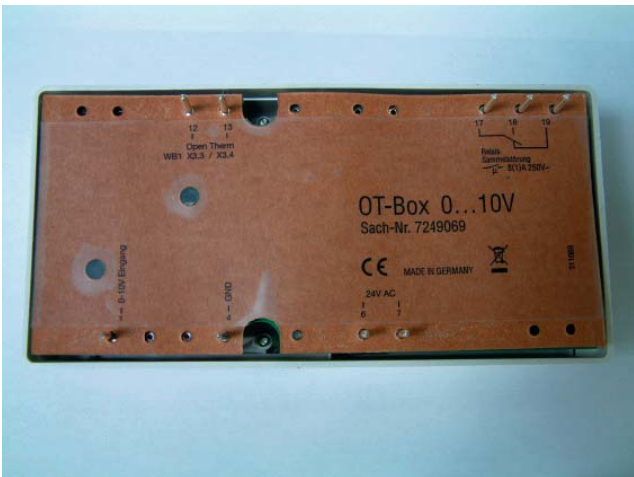

Fig. 6
Rear view of Input Module

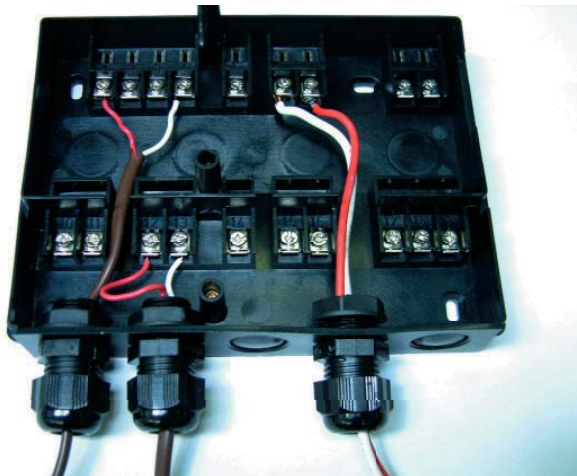

Fig. 7
Input Module sub-base / control unit

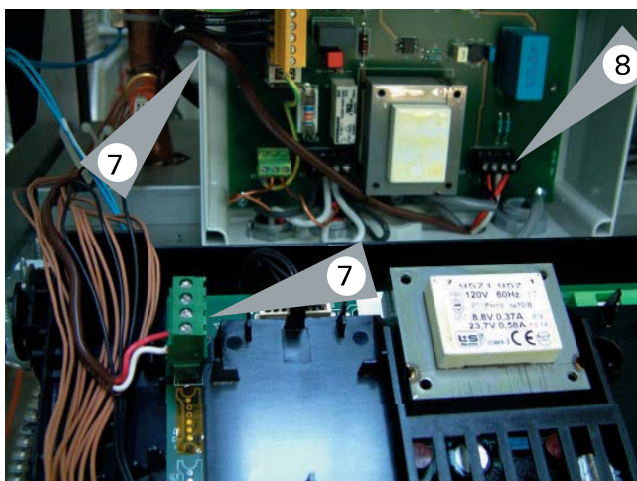
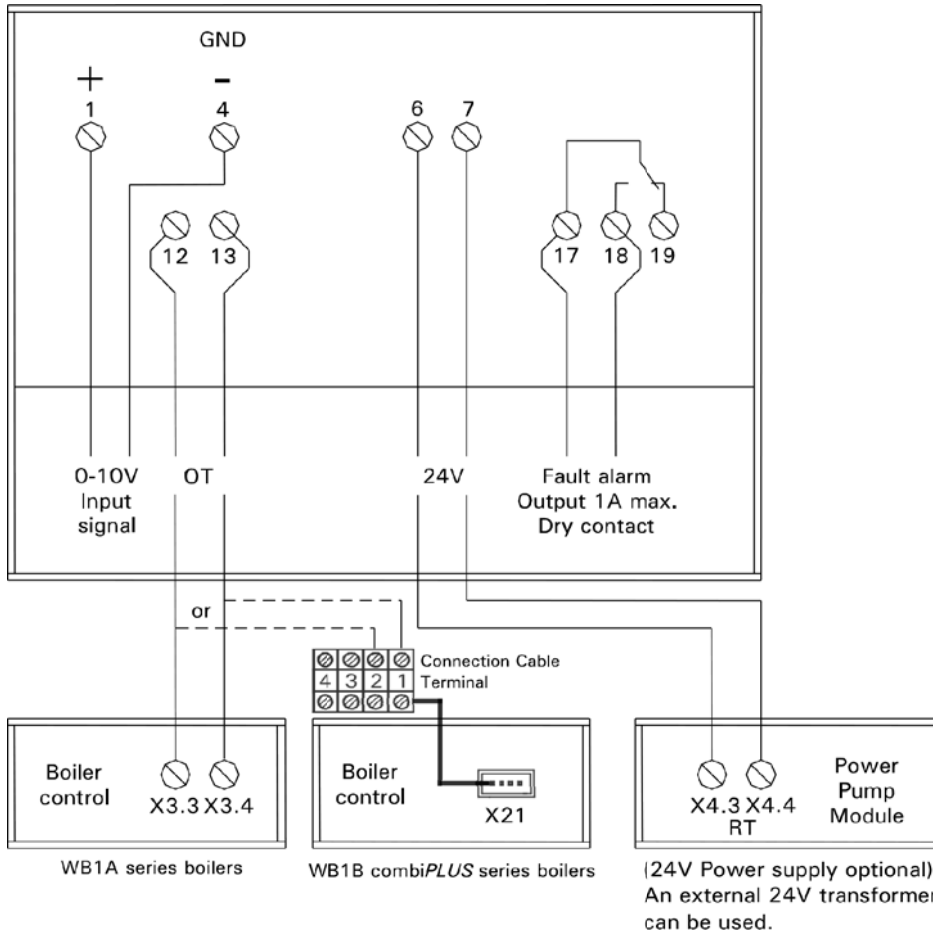

Fig. 8
Boiler Power Pump Module (WB1A shown)

5. Mount terminal base onto wall close to the boiler.
6. Make electrical connections. (See wiring diagram on page 5)
7. Run Input Module communication cable (2-wire 18AWG) through Power Pump Module to boiler control sub-base Terminal X3.3, X3.4 for WB1A series boilers or X21.1, X21.2 for WB1B CombiPLUS series boilers, or to connection terminals X21.1, X21.2 on the B1HA/B1KA series boilers.
8. Connect power supply harness to RT terminals in the Power Pump Module Terminals X4.3 and X4.4.
Note: B1HA/B1KA requires an external 24VAC power source (field supplied).

Wiring Diagram WB1A, WB1B boiler series



If needed (service or emergency heat request), a call for heat can be initiated by jumpering Terminal X3.3, X3.4 or X21.1, X21.2 on the boiler control or Terminals 12, 13 on the Input Module sub-base. The boiler will operate as it would with room thermostat operation and will cycle on the adjustable high limit setting.



Refer to the Vitodens 100 Operating Instructions.

A call for domestic hot water or external heat demand (closing the ST contacts on the PPM of the boiler) has priority over a call from the Input Module. The boiler will operate with a constant setpoint of 78°C / 172°F during a call for domestic hot water.

Fig. 9
Input Module wiring diagram

Wiring Diagram B1HA, B1KA boiler series

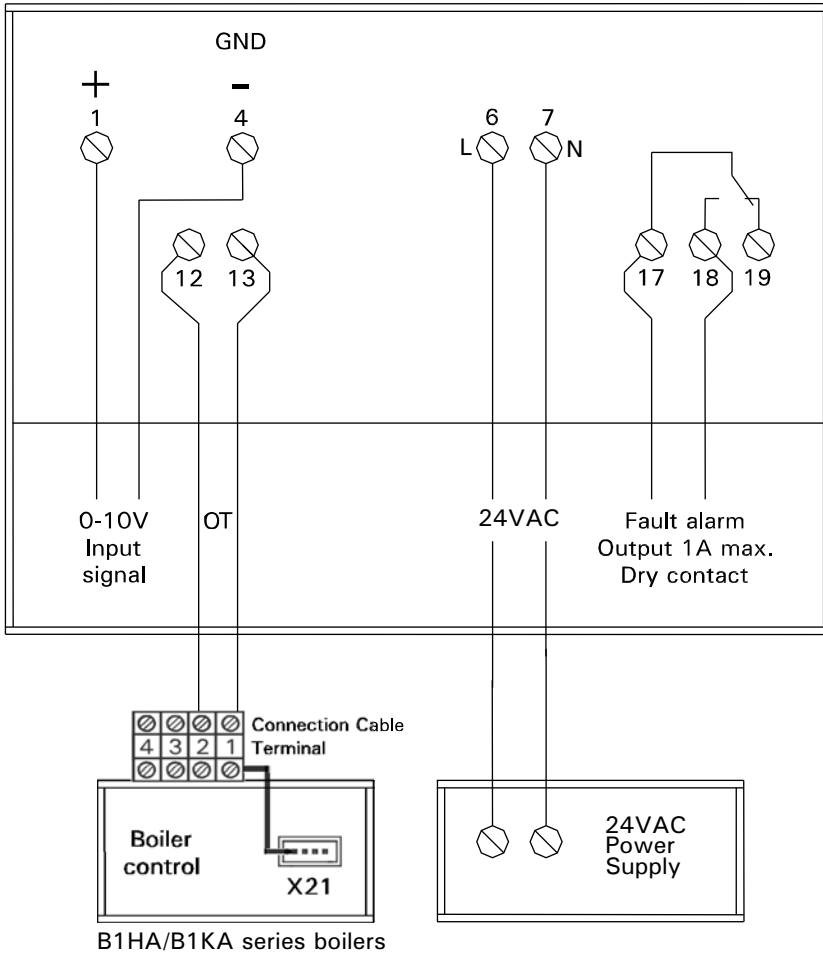

If needed (service or emergency heat request), a call for heat can be initiated by jumpering Terminal X21.1, X21.2 on the boiler control or Terminals 12, 13 on the Input Module sub-base. The boiler will operate as it would with room thermostat operation and will cycle on the adjustable high limit setting.



Refer to the Vitodens 100 Operating Instructions.

A call for domestic hot water or external heat demand has priority over a call from the Input Module. The boiler will operate with a constant setpoint of 176°F (80°C) during a call for domestic hot water.

Fig.10
Input Module wiring diagram

LED Display Status

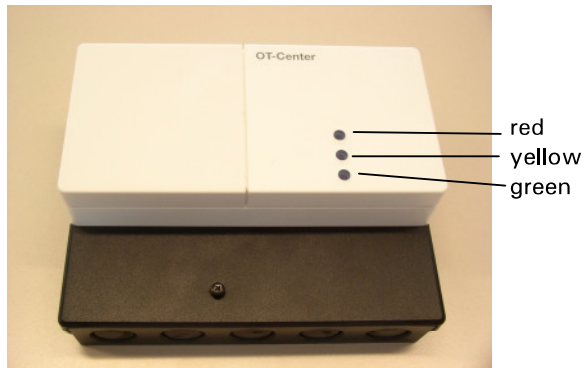

LED red	Fault alarm output (dry contact) maximum 1A (Terminals 18-19 closed)
LED yellow	Call for heat
LED green (flashing)	Bus communication established between boiler and Input Module

Fig. 11
Input Module LED display

Troubleshooting

Fault display on the boiler control unit (WB1A, WB1B series)

Fault message in display window	System behavior	Cause	Corrective measures
 (red light flashing)	Non-permanent lockout (boiler in fault mode)	Communication error OpenTherm interface	Turn boiler OFF, then ON Check communication cable on Terminals X3.3, X3.4 or X21.1, X21.2 on boiler controls. Check connection on Input Module sub-base Terminals 12, 13. Check 24VAC output of PPM of the boiler Terminals X4.3, X4.4 (RT Terminals). Check for 0-10VDC input signal (a min. of 3.0 V is required to start up the boiler).

Fault display on the boiler control unit (B1HA, B1KA series)

Fault message in display window	System behavior	Cause	Corrective measures
	Regulated operation without OpenTherm device	Communication fault OpenTherm device	Check connections and wire; replace OpenTherm device if required.



Viessmann Manufacturing Company ULC
750 McMurray Road
Waterloo, Ontario • N2V 2G5 • Canada
TechInfo Line 1-888-484-8643
1-800-387-7373 • Fax (519) 885-0887
www.viessmann.ca • info@viessmann.ca

Viessmann Manufacturing Company (U.S.) Inc.
45 Access Road
Warwick, Rhode Island • 02886 • USA
TechInfo Line 1-888-484-8643
1-800-288-0667 • Fax (401) 732-0590
www.viessmann-us.com • info@viessmann-us.com

Technical information subject to change without notice

5351 049 - 02