

Technical Data Manual

Model Nos. and pricing : See Price List



DLFUAAH

Models 18XAK, 24XAK, 30XAK, 36XAK, 48XAK, and 60XAK

Air Handler Unit

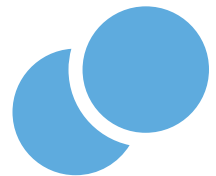

VITOCAL IND-A



Product may not be exactly as shown



INDUSTRY LEADING FEATURES / BENEFITS

SECURE OPERATION

If security is an issue, outdoor and indoor units are connected only by refrigerant piping and wiring to prevent intruders from crawling through the ductwork. In addition, since outdoor units can be installed close to an outside wall, coils are protected from vandals and severe weather.

FAST INSTALLATION

This compact ductless system is simple to install. This makes the air handler systems the equipment of choice, especially in retrofit situations.

On all indoor units, service and maintenance expense is reduced due to easy accessible service panels. In addition, these air handler systems have extensive self-diagnostics to assist in troubleshooting.

BUILT-IN RELIABILITY

The air handler system indoor and outdoor units are designed to provide years of trouble-free operation.

The air handler indoor units include protection against freeze-up and high evaporator temperatures on heat pumps.

The condensing units on the heat pumps are protected by a three minute delay that provides over-current protection and high temperature protection prior to the start of the compressor.

ECONOMICAL OPERATION

The air handler system design allows individual or multi-room heating or cooling when required. There is no need to run large supply-air fans or chilled water pumps to handle a few spaces with unique load patterns.

EASY-TO-USE CONTROLS

The air handler units have microprocessor-based controls to provide the ultimate in comfort and efficiency. The user-friendly control provides the interface between the user and the unit.

MULTI-POISE INSTALLATION

Designed for maximum installation flexibility. The secondary drain built-in allows the unit to be mounted in an upflow, downflow, left or right installation depending on existing conditions.

24V INTERFACE

The built-in 24V Interface allows users to control the system with a third party thermostat.

AGENCY LISTINGS

All systems are listed with AHRI (Air Conditioning, Heating & Refrigeration Institute), UL/ETL and CSA.

MODEL NUMBER NOMENCLATURE

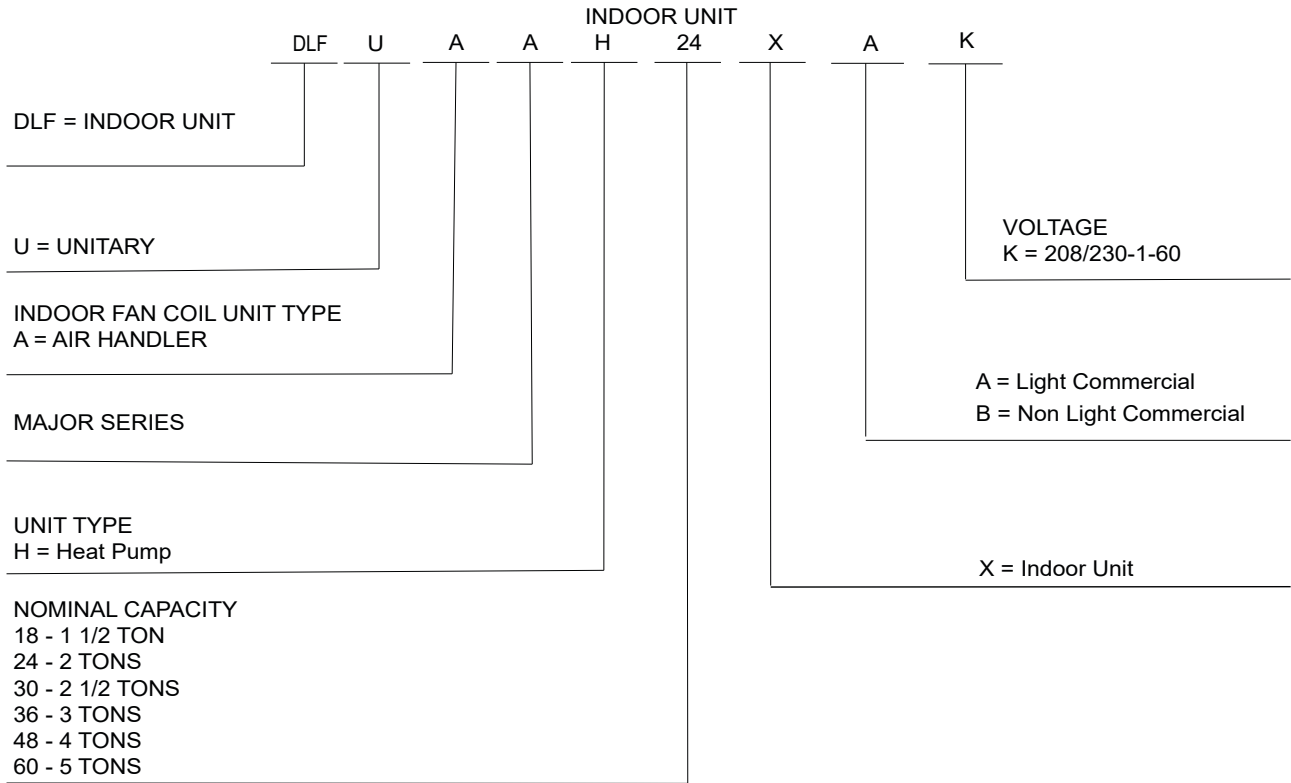

Loren ipsum

A220909

Fig. 2 — Model Number Nomenclature



Use of the AHRI Certified TM Mark indicates a manufacturer's participation in the program. For verification of certification for individual products, go to www.ahridirectory.org.

Fig. 3 — AHRI Certified

A220910

STANDARD FEATURES AND ACCESSORIES

Table 1 — Standard Features

EASE OF INSTALLATION	
Low Voltage Controls	S
COMFORT FEATURES	
Microprocessor Controls	S
24V Interface built-in for third party thermostat controls	S
Wireless Remote Controller	S
Wired Remote Controller (Sold separately)	S
Auto Restart Function	S
Cold Blow Protection on Heat Pumps	S
Freeze Protection Mode on Heat Pumps	S
Turbo Mode	S
Auto Changeover on Heat Pumps	S
SAFETY AND RELIABILITY	
Indoor Coil Freeze Protection	S
Anti-corrosive pre-coated fins	S
Indoor Coil High Temp Protection in Heating Mode	S
EASE OF SERVICE AND MAINTENANCE	
Cleanable Filters	S
Diagnostics	S
APPLICATION FLEXIBILITY	
Multi-poise Installation	S

* Only available by using receiver in wired controller KSACN1001 (sold separately).

Legend

S - Standard

A - Accessory

Table 2 — Accessories

ORDERING NO.	DESCRIPTION	FOR MODELS
EHKMB05KN	Electric Heater Kit 5kW	18K, 24K, 30K, 36K
EHKMB08KN	Electric Heater Kit 8kW	18K, 24K, 30K, 36K, 48K
EHKMB10KN	Electric Heater Kit 10kW	18K, 24K, 30K, 36K, 48K, 60K
EHKMB15KN	Electric Heater Kit 15kW	24K, 30K, 36K, 48K, 60K
EHKMB20KN	Electric Heater Kit 20kW	36K, 48K, 60K
EHKMB25KN	Electric Heater Kit 25kW	60K
DGAPAXXX1620	1500 CFM Air Purifier	18K, 24K
DGAPAXXX2020	1750 CFM Air Purifier	30K, 36K, 48K
DGAPAXXX2420	2188 CFM Air Purifier	60K

NOTE: The unit is NOT equipped with a single point electrical connection for electric heater, air purifier or other peripherals. A separate power supply is required.

MULTI-POISE INSTALLATION

Designed for maximum installation flexibility. The secondary drain built-in allows the unit to be mounted in an upflow, downflow, left or right installation depending on existing conditions.

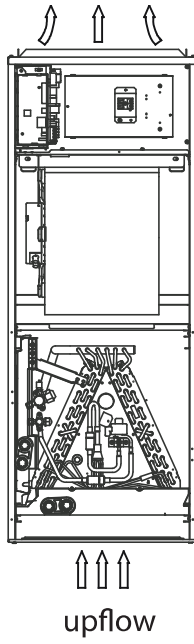

Fig. 4 — Vertical Upflow Installation

A220771

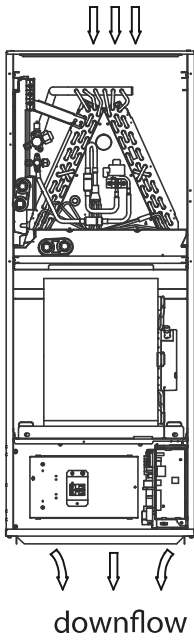
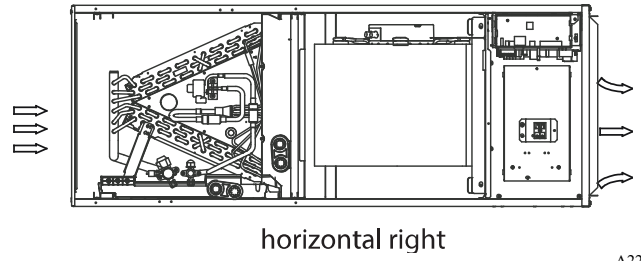

Fig. 5 — Downflow Illustration

A220788



horizontal right

A220789

Fig. 6 — Horizontal Right Installation

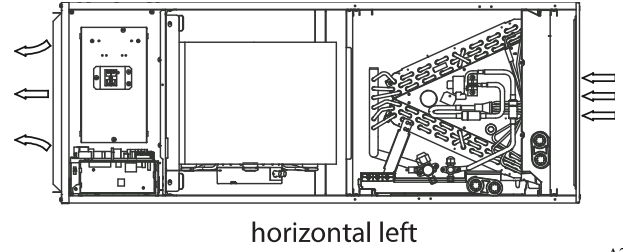

horizontal left

A220772

Fig. 7 — Horizontal Left installation

DIMENSIONS

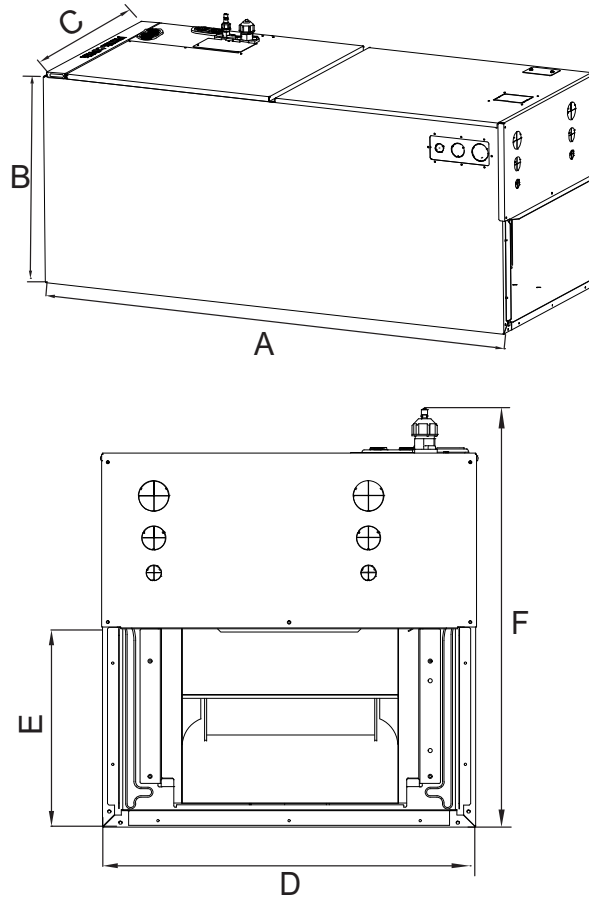

A220911

Model	Dimensions					
	A (Height)	B (Depth)	C (Width)	D	E	F
18K-24K	45in	21in	17.5in	15.75in	10.25in	23in
	(1143mm)	(534mm)	(445mm)	(400mm)	(260mm)	(585mm)
30K-48K	49in	21in	21in	19.31in	10.25in	23in
	(1245mm)	(534mm)	(534mm)	(490mm)	(260mm)	(585mm)
60K	53in	21in	24.5in	22.88in	10.25in	23in
	(1346mm)	(534mm)	(622mm)	(580mm)	(260mm)	(585mm)

Fig. 8 —DLFUAA Dimensions

Recommended size of filter Unit: Inch/mm)

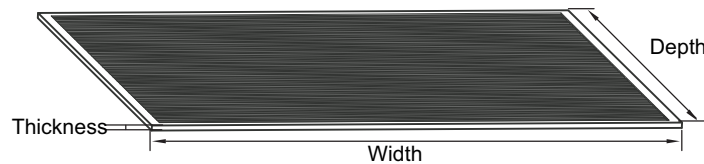

A220850

Model (Btu/h)	Width		Depth		Thickness	
	Inch	mm	Inch	mm	Inch	mm
18-24K	16	406.4	20	508	1	25.4
30-48K	19-1/2	495.3	20	508	1	25.4
60K	23	584.2	20	508	1	25.4

Fig. 9 —Recommended Filter Size

CLEARANCES

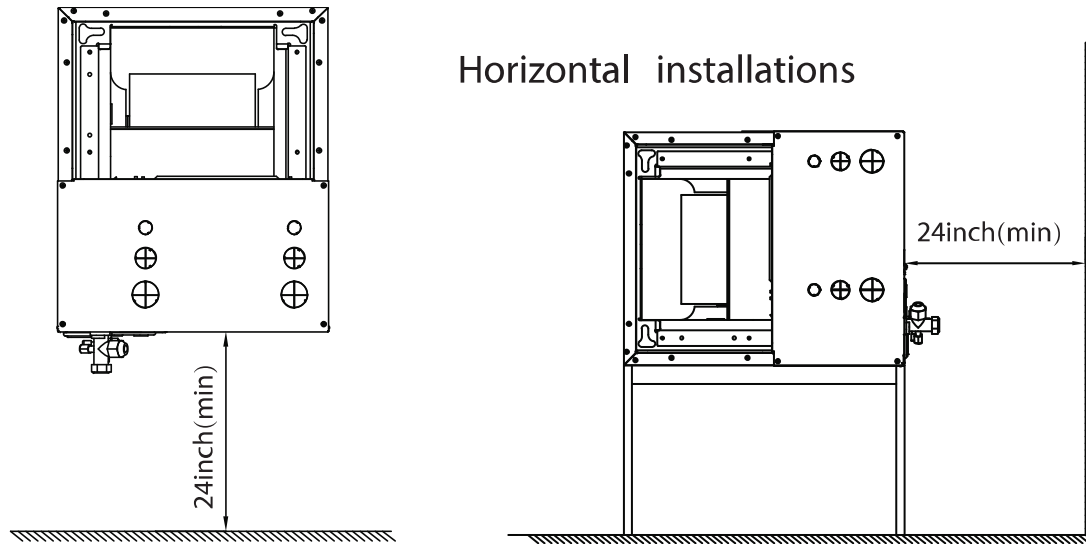

Fig. 10 — Clearances

A220769

SPECIFICATIONS

Table 3 — Specifications

System	Indoor Size		18K	24K	30K	36K	48K	60K
Electrical	Voltage, Phase, Cycle	V/Ph/Hz	208/230-1-60	208/230-1-60	208/230-1-60	208/230-1-60	208/230-1-60	208/230-1-60
	MCA	A.	2.5	4	4.5	5	7.5	9
	Recommended Fuse Size	A.	5	5	5	10	10	10
	MOPA - Fuse Rating	A.	15	15	15	15	15	15
Operating Range	Cooling Indoor DB Min - Max	°F(°C)	60~90 (16~32)	60~90 (16~32)	60~90 (16~32)	60~90 (16~32)	60~90 (16~32)	60~90 (16~32)
	Heating Indoor DB Min - Max	°F(°C)	32~86(0~30)	32~86(0~30)	32~86(0~30)	32~86(0~30)	32~86(0~30)	32~86(0~30)
Piping	Pipe Connection Size - Liquid	in (mm)	3/8 (9.52)	3/8 (9.52)	3/8 (9.52)	3/8 (9.52)	3/8 (9.52)	3/8 (9.52)
	Pipe Connection Size - Suction	in (mm)	3/4 (19)	3/4 (19)	3/4 (19)	3/4 (19)	3/4 (19)	7/8 (22)
Refrigerant	Refrigerant Type		R410A	R410A	R410A	R410A	R410A	R410A
	Metering Device		EEV	EEV	EEV	EEV	EEV	EEV
Indoor Coil	Face Area	Sq. Ft.	3	3	3.8	3.8	3.8	4.88
	No. Rows		3	3	4	4	4	5
	Fins per inch		20	20	20	20	20	20
	Circuits		6	6	10	10	10	14
Airflow & Sound	Number of Fan Speeds (low/med/high/turbo)		4	4	4	4	4	4
	Nominal Airflow (lowest to highest)	CFM	488/529/576/618	629/694/759/824	712/806/894/1088	865/971/1082/1188	906/1094/1282/1471	1135/1359/1582/1806
	Cooling Sound Pressure (low to high)	dB(A)	30.5/31.4/33.4/35.2	33.6/36.6/38.7/40.4	37.7/41.3/43.0/45.6	40.2/43.2/45.7/48.0	42.5/47.1/50.3/54.0	45.0/49.1/52.1/55.3
	Heating Sound Pressure (low to high)	dB(A)	29.8/30.7/34.0/35.3	32.4/36.9/39.6/40.6	29.5/36.9/43.0/43.2	35.6/40.7/46.8/46.7	43.7/46.8/50.2/52.7	43.4/48.0/53.0/60.5
	Max Static Pressure	In. W.G.	0.8	0.8	0.8	0.8	0.8	0.8
	Field Drain Pipe Size O.D.	in (mm)	3/4 (19.1)	3/4 (19.1)	3/4 (19.1)	3/4 (19.1)	3/4 (19.1)	3/4 (19.1)

APPLICATION DATA

UNIT SELECTION

Select equipment to either match or that can handle slightly less than the anticipated peak load. This provides better humidity control, fewer unit cycles, and less part-load operation.

For units used in spaces with high sensible loads, base equipment selection on unit sensible load, not on a total anticipated load. Adjust for anticipated room wet bulb temperature to avoid undersizing equipment.

UNIT MOUNTING (INDOOR)

Refer to the unit's installation instructions for further details.

Unit leveling - For reliable operation, units should be level in all planes.

Clearance - Provide adequate clearance for airflow (see Fig. 10 — on page 7).

Unit location - Select a location which provides the best air circulation for the space.

Do not install the indoor or outdoor units in a location with special environmental conditions. For those applications, contact your ductless representative.

SUPPORT

Adequate support must be provided to support the weight of all fan coils. Refer to the "SPECIFICATIONS" on page 7 for fan coil weights. Refer to "DIMENSIONS" on page 6 for the base unit dimensional drawings which contain the location of the mounting brackets.

Table 4 — Indoor Unit Operating Conditions

System size		Ductless Air Handler			
		ALL SIZES			
Operating Range	Cooling				
	Indoor Min - Max DB	°F(°C)	60~90 (16~32)		
	Indoor Min - Max WB	°F(°C)	59~84 (15~29)		
Operating Range	Heating				
	Indoor DB Min -Max	°F(°C)	32~86(0~30)		
Non-Operating	Temperature range (DB)	°F(°C)	32-86(0-30)	32-86(0-30)	32-86(0-30)
	Operation Humidity	%	0-80%	0-80%	0-80%
	Ambient Humidity	%	0-80%	0-80%	0-80%

Table 5 — Outdoor Operating Conditions

Operating Range and Humidity		High Heat Models	Regular Models	
Operating Range	Cooling Outdoor Min - Max DB	°F	-22~130	5~130
		°C	-30~55	-15~55
	Heating Outdoor Min - Max DB	°F	-22~86	-5~86
		°C	-30~30	-15~30
Operating Humidity		%	0~80	0~80

NOTE: Reference the unit's installation instructions for more information.

DRAIN CONNECTIONS

Install the drains in compliance with the local sanitation codes.

INDOOR UNIT WIRING

Before proceeding with electrical connections, make certain that the supply voltage, frequency, phase, and ampacity are as specified on the unit rating plate. Review the unit wiring label for proper field high and low voltage wiring.

Ensure all electrical connections are in accordance with the NEC and any local codes or ordinances that may apply. Use copper wire **only**.



CAUTION

PROPERTY DAMAGE HAZARD

Failure to follow this caution may result in product or property damage. If a disconnect switch is to be mounted on the unit, select a location where the drill or fastener will not contact electrical or refrigerant components.



WARNING

ELECTRICAL SHOCK HAZARD

Failure to follow this warning could result in personal injury or death. Field wires on the line side of the disconnect found in the fan coil unit remain live, even when the pull-out is removed. Service and maintenance to incoming wiring cannot be performed until the main disconnect switch (remote to the unit) is turned off.



CAUTION

EQUIPMENT DAMAGE HAZARD

Failure to follow this caution may result in equipment damage or improper operation. Size the wires in accordance with NEC and local codes.

Use the following steps to wire the indoor unit.

NOTE: Wiring in this section is for the base unit ONLY.

- Prepare the cable for connection.
 - Using wire strippers, strip the insulation from both ends of the signal cable to reveal about 1/2 in (12mm) of wire.
 - Strip the insulation from both ends of the wires.
 - Use a wire crimper to crimp the fork terminals to the ends of the wires.
- Open the indoor unit's front panel. Use a screwdriver to remove the cover of the electric control box on the indoor unit.
- Thread the power cable and the signal cable through the wire outlet.
- Connect the fork terminals to the terminals. Match the wire colors/labels with the labels on the terminal block.

- Firmly screw the fork terminals of each wire to its corresponding terminal. Refer to the serial number and wiring diagram located on the cover of the electric control box.

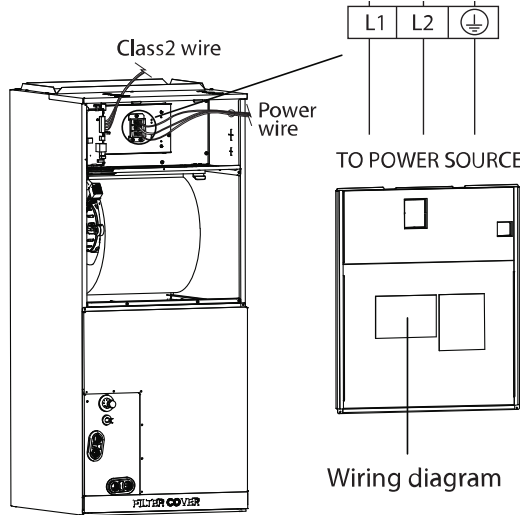

Fig. 11 —Indoor Unit Power Wiring

A220802

NOTE: The electric auxiliary heat wiring diagram is supplied with the accessories. Paste the wiring diagram in the designated position after installing the heat modules.

CAUTION

While connecting the wires, strictly follow the wiring diagram. The refrigerant circuit can become very hot. Keep the interconnection cable away from the copper tube.

- Clamp down the cable with the cable clamp. The cable must not be loose or put strain on the fork terminals.
- Reattach the electric box cover.

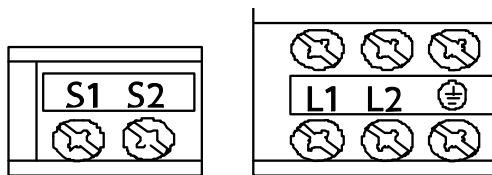

A220826

Fig. 12 —Controls and Power Terminals on Indoor Unit (All Sizes)

WIRING REQUIREMENTS

Size all wires per the NEC (National Electrical Code) or CEC (Canadian Electrical Code) and local codes. Use the electrical data from the outdoor unit (MCA - minimum circuit amps and MOCP - maximum over current protection), to correctly size the wires and the disconnect fuse or breakers respectively.

Communication Wiring: There are two options available to establish communication between the outdoor unit and approved indoor unit.

Table 6 — Options for Establishing Communication

OPTIONS	COMMUNICATION TYPE	RECOMMENDED CABLE SIZE
1	Non-Polarity RS485 Communication (S1 - S2)	16 AWG (stranded shielded)
2	24V communication	18 AWG 8 conductor thermostat wire

WARNING

Refer to the wiring template for the wiring method.
DO NOT connect the power cord to the communication line as this may damage the system.

CAUTION

EQUIPMENT DAMAGE HAZARD

Be sure to comply with local codes while running wire from the indoor unit to the outdoor unit.

Every wire must be connected firmly. Loose wiring may cause the terminal to overheat or result in a unit malfunction. A fire hazard may also exist. Ensure all wiring is tightly connected.

No wire should touch the refrigerant tubing, compressor or any moving parts.

Disconnecting means must be provided and located within sight and readily accessible from the system. Route the connecting cable with conduit through the hole in the conduit panel.

NOTE: Separate power is required for an Auxiliary Electric Heater.

CAUTION

EQUIPMENT DAMAGE HAZARD

Comply with local codes while running wire from the indoor unit to the outdoor unit. Every wire must be connected firmly. Loose wiring may cause the terminal to overheat or result in a unit malfunction. A fire hazard may also exist. Ensure all wiring is tightly connected.

No wire should touch the refrigerant tubing, compressor or any moving parts.

Disconnecting means must be provided and located within sight and readily accessible from the system. Route the connecting cable with conduit through the hole in the conduit panel.

CONTROL SYSTEM

The indoor unit is equipped with a microprocessor control to perform two functions:

- Provide safety for the system
- Control the system and provide optimum levels of comfort and efficiency.

The main microprocessor is located on the control board of the fan coil unit (outdoor units have a microprocessor also) with thermistors located in the fan coil air inlet and on the indoor coil. Heat pump units have a thermistor on the outdoor coil. These thermistors monitor the system's operation to keep the unit within acceptable parameters and control the operating mode.

WIRED REMOTE CONTROLLER



Fig. 13 — Wired Remote Controller

Wired remote controller KSACN1001AAA sold separately.

A220918

24 VOLT INTERFACE

The indoor unit comes equipped with a 24V interface that provides further flexibility, functionality and control allowing it to be controlled by any 3rd party heat pump thermostat (field supplied).

NOTE: A conventional 5-wire thermostat is required. A 2 heat/1 cool thermostat is required for electric heat applications.

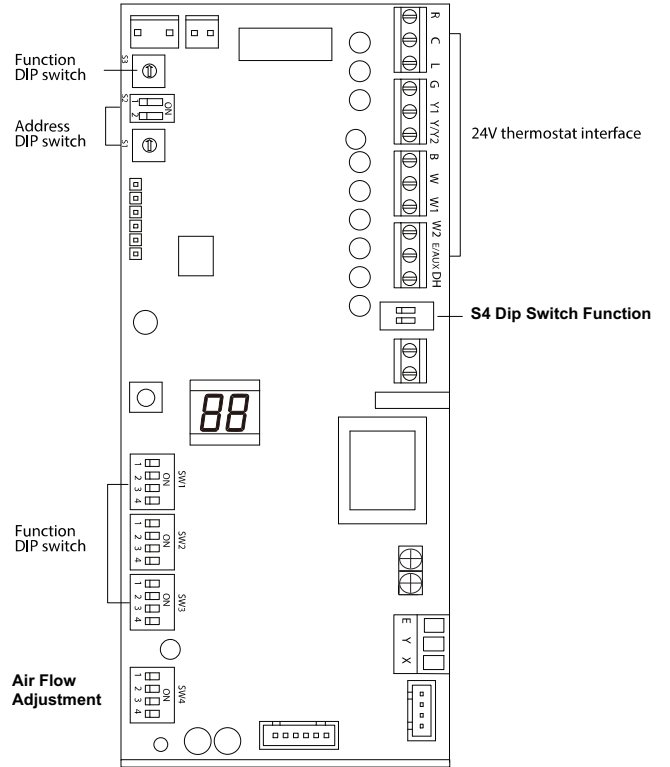

A220843

Fig. 14 — 24 Volt Interface

AIR FLOW DATA

Table 7 — Air Flow Data

SYSTEM SIZE		18K	24K	30K	36K	48K	60K
		(208/230V)	(208/230V)	(208/230V)	(208/230V)	(208/230V)	(208/230V)
Airflow** (CFM)	Turbo	618	824	1,088	1,188	1,471	1,806
	High	576	759	894	1,082	1,282	1,582
	Medium	529	694	806	971	1,094	1,359
	Low	488	629	712	865	906	1,135

Airflow values obtained at AHRI 210/240 rating conditions.

**Measured at rates static pressure:

18K-24K: 0.1 in. WG (25pa)

30K-36K: 0.15 in. WG (37pa)

48K-60K: 0.2 in. WG (50pa)

SOUND PRESSURE

Table 8 — Sound Pressure

Ducted Indoor		18K (208/230V)	24K (208/230V)	30K (208/230V)	36K (208/230V)	48K (208/230V)	60K (208/230V)
**Cooling operation Indoor Sound Pressure	dBA at (Turbo/ High / Med / Low CFM)	35.2/	40.4/	45.6/	48.0/	54.0/	55.3/
		33.4/	38.7/	43.0/	45.7/	50.3/	52.1/
		31.4/	36.6/	41.3/	43.2/	47.1/	49.1/
		30.5	33.6	37.7	40.2	42.5	45.0
**Heating operation Indoor Sound Pressure	dBA at (Turbo/ High / Med / Low CFM)	35.3/	40.6/	43.2/	46.7/	52.7/	60.5/
		34.0/	39.6/	43.0/	46.8/	50.2/	53.0/
		30.7/	36.9/	36.9/	40.7/	46.8/	48.0/
		29.8	32.4	29.5	35.6	43.7	43.4

SOUND PRESSURE IN OCTAVE BANDS

Table 9 — Sound Pressure In Octave Bands

SIZE	Frequency (Hz)	63	125	250	500	1000	2000	4000	8000
18k	Cooling dB(A)	39.1	37.2	32.8	28.7	28.1	26.0	22.8	20.8
	Heating dB(A)	40.8	38.0	33.3	28.4	28.6	25.8	25.2	21.2
24k	Cooling dB(A)	43.9	44.5	39.0	32.2	32.7	31.2	27.3	23.6
	Heating dB(A)	43.3	45.5	36.8	32.4	34.3	32.5	30.2	24.5
30K	Cooling dB(A)	45.6	48.0	40.4	34.6	38.4	35.9	34.0	28.3
	Heating dB(A)	44.3	48.6	40.6	35.7	38.6	35.8	31.9	25.3
36k	Cooling dB(A)	47.7	51.6	45.1	39.2	40.3	38.7	36.2	33.2
	Heating dB(A)	44.7	50.8	42.8	38.8	40.6	37.4	35.2	35.0
48k	Cooling dB(A)	52.1	56.1	47.7	41.2	46.3	43.0	40.5	36.0
	Heating dB(A)	51.0	55.3	48.2	42.1	45.7	42.7	40.4	36.0
60k	Cooling dB(A)	58.8	53.9	52.2	46.3	46.1	45.9	41.5	35.4
	Heating dB(A)	59.9	54.9	49.8	50.1	47.5	45.5	42.7	35.0

SOUND PRESSURE TESTING METHOD

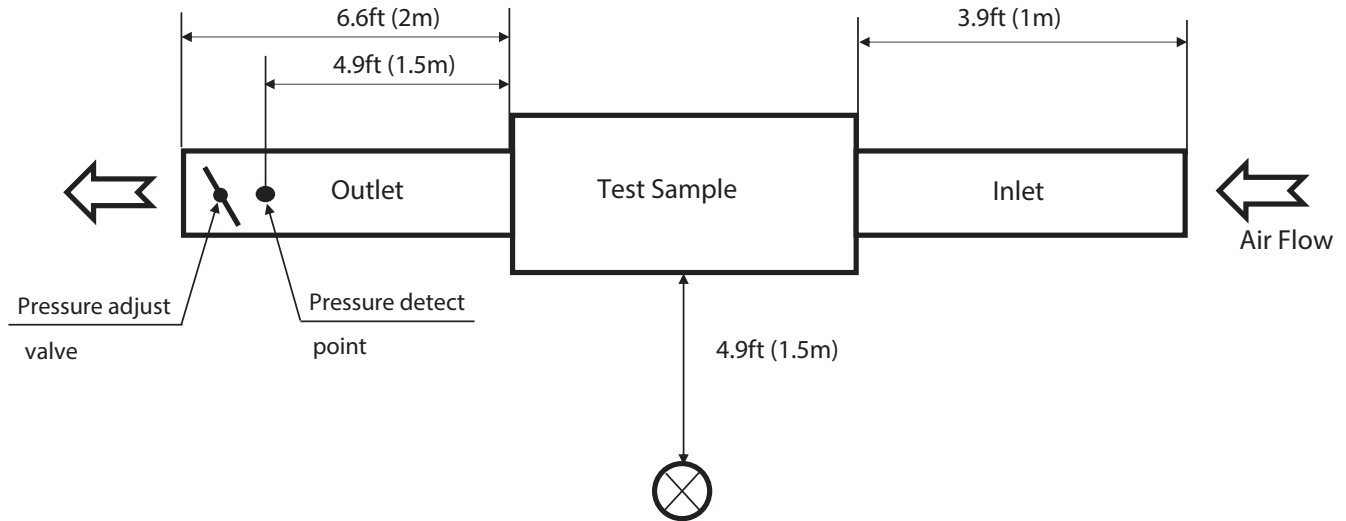

Fig. 15 — Sound Pressure Testing Method

FAN AND MOTOR SPECIFICATIONS

Table 10 — Fan and Motor Specifications

DUCTED SIZES		18K	24K	30K/36K	48K	60K	
INDOOR FAN	Material	Metal					
	Diameter	inch	10.63	10.63	11.1	11.1	10.98
	Height	inch	8.15	8.15	9.65	9.65	10.67
INDOOR FAN MOTOR	Model	ZKFD-250-8-1	ZKFD-250-8-1	ZKFD-375-8-1-1	ZKFD-560-8-1-1	ZKFD-750-8-1-1	
	Volts	V	208/230	208/230	208/230	208/230	208/230
	Type	DC					
	Phase	3					
	FLA		2	3	3.5	3.5	7
	Insulation class	B					
	Safe class	IPX0					
	Input	W	67.8	67.8	168	235	286.5
	Output	W	250	250	375	560	750
	Range of current	Amps	0.66±15%	0.66±15%	1.4±15%	1.9±15%	2.26±15%
	Rated current	Amps	0.66	0.66	1.4	1.9	2.26
	Rated HP	HP	1/3	1/3	1/2	3/4	1
	Speed	rev/min	550/510/450	550/510/450	685/620/560	780/685/580	820/720/615
Rated RPM	rev/min	550	550	685	780	820	
Max. input	W	67.8	67.8	168	235	286.5	

Table 11 — Turbo, High, Medium, Low Air Volume Parameters

18K			24K			30K			36K			48K			60K		
The PWM duty cycle	Static pressure	Air volume (CFM)	The PWM duty cycle	Static pressure	Air volume (CFM)	The PWM duty cycle	Static pressure	Air volume (CFM)	The PWM duty cycle	Static pressure	Air volume (CFM)	The PWM duty cycle	Static pressure	Air volume (CFM)	The PWM duty cycle	Static pressure	Air volume (CFM)
Low	0	489	Low	0	598	Low	0	422	Low	0	879	Low	0	946	Low	0	1151
	0.10"	493		0.10"	613		0.10"	705		0.10"	883		0.10"	943		0.10"	1133
	0.15"	490		0.15"	625		0.15"	713		0.15"	888		0.15"	942		0.15"	1136
	0.20"	488		0.20"	630		0.20"	705		0.20"	892		0.20"	948		0.20"	1132
	0.30"	501		0.30"	632		0.30"	708		0.30"	893		0.30"	947		0.30"	1128
	0.40"	497		0.40"	635		0.40"	711		0.40"	893		0.40"	940		0.40"	1134
	0.50"	495		0.50"	631		0.50"	707		0.50"	892		0.50"	940		0.50"	1130
	0.60"	492		0.60"	624		0.60"	704		0.60"	890		0.60"	933		0.60"	1133
	0.80"	489		0.80"	614		0.80"	702		0.80"	873		0.80"	925		0.80"	1126
	1.00"	488		1.00"	624		1.00"	698		1.00"	826		1.00"	925		1.00"	1118
Mid	0	524	Mid	0	692	Mid	0	813	Mid	0	1010	Mid	0	1155	Mid	0	1367
	0.10"	528		0.10"	690		0.10"	811		0.10"	1001		0.10"	1156		0.10"	1358
	0.15"	532		0.15"	685		0.15"	813		0.15"	1001		0.15"	1154		0.15"	1362
	0.20"	542		0.20"	695		0.20"	816		0.20"	1000		0.20"	1154		0.20"	1361
	0.30"	523		0.30"	693		0.30"	815		0.30"	995		0.30"	1143		0.30"	1360
	0.40"	524		0.40"	692		0.40"	811		0.40"	995		0.40"	1147		0.40"	1352
	0.50"	533		0.50"	688		0.50"	809		0.50"	996		0.50"	1149		0.50"	1353
	0.60"	523		0.60"	684		0.60"	801		0.60"	983		0.60"	1143		0.60"	1348
	0.80"	521		0.80"	670		0.80"	807		0.80"	996		0.80"	1140		0.80"	1340
	1.00"	519		1.00"	654		1.00"	801		1.00"	969		1.00"	1113		1.00"	1316
High	0	573	High	0	752	High	0	899	High	0	1137	High	0	1325	High	0	1608
	0.10"	577		0.10"	746		0.10"	895		0.10"	1123		0.10"	1328		0.10"	1590
	0.15"	580		0.15"	750		0.15"	902		0.15"	1119		0.15"	1337		0.15"	1586
	0.20"	576		0.20"	756		0.20"	898		0.20"	1120		0.20"	1337		0.20"	1560
	0.30"	579		0.30"	750		0.30"	900		0.30"	1112		0.30"	1330		0.30"	1561
	0.40"	574		0.40"	746		0.40"	909		0.40"	1111		0.40"	1333		0.40"	1554
	0.50"	573		0.50"	741		0.50"	901		0.50"	1113		0.50"	1338		0.50"	1549
	0.60"	576		0.60"	745		0.60"	908		0.60"	1101		0.60"	1335		0.60"	1545
	0.80"	577		0.80"	735		0.80"	905		0.80"	1094		0.80"	1321		0.80"	1543
	1.00"	574		1.00"	714		1.00"	899		1.00"	1088		1.00"	1321		1.00"	1548
Turbo	0	611	Turbo	0	820	Turbo	0	986	Turbo	0	1179	Turbo	0	1465	Turbo	0	1799
	0.10"	616		0.10"	826		0.10"	983		0.10"	1181		0.10"	1468		0.10"	1801
	0.15"	617		0.15"	822		0.15"	982		0.15"	1188		0.15"	1479		0.15"	1798
	0.20"	614		0.20"	821		0.20"	980		0.20"	1180		0.20"	1469		0.20"	1792
	0.30"	612		0.30"	826		0.30"	988		0.30"	1182		0.30"	1466		0.30"	1800
	0.40"	618		0.40"	822		0.40"	989		0.40"	1191		0.40"	1476		0.40"	1808
	0.50"	622		0.50"	828		0.50"	986		0.50"	1180		0.50"	1468		0.50"	1796
	0.60"	610		0.60"	818		0.60"	993		0.60"	1190		0.60"	1478		0.60"	1798
	0.70"	613		0.70"	824		0.70"	990		0.70"	1198		0.70"	1471		0.70"	1812
	0.80"	618		0.80"	823		0.80"	988		0.80"	1188		0.80"	1472		0.80"	1806

WIRING DIAGRAMS

NOTE1:

- 1.The parts with dotted line indicates optional features.
- 2.Remove the short connector of JR1 when you use the "on-off" function.
- 3.Remove the short connector of J1 when you use the "WATER LEVEL SWITCH" function.
4. This symbol indicates the element is optional, the actual shape shall prevail.

WIRING DIAGRAM

CODE	PART NAME
ECM	INDOOR ECM MOTOR
T1	ROOM TEMP.SENSOR
T2	COIL TEMP.SENSOR
T2A	INDOOR COIL INLET TEMP.SENSOR
T2B	INDOOR COIL OUTLET TEMP.SENSOR

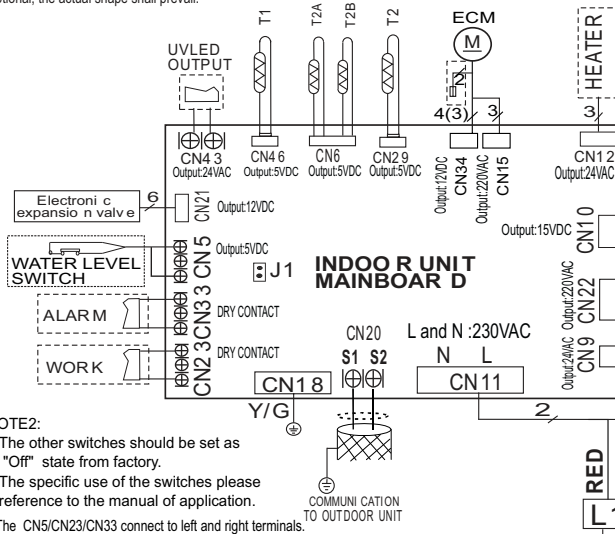

NOTE2:

- 1.The other switches should be set as "Off" state from factory.
- 2.The specific use of the switches please reference to the manual of application.
- 3.The CN5/CN23/CN33 connect to left and right terminals.

FOR SETTING POWER(DC MOTOR MODEL ONLY)

ENC1	CODE	CAPACITY	FACTORY SETTING
	4	≤53	ACCORDING TO RELATED MODEL.
	5	54~71	
	7	72~90	
	8	91~105	
	9	106~140	
	A	141~160	
	B	≥161	

24V THERMOSTATS SETTING

CODE	FACTORY SETTING
S3	ON-OFF
SW1	ON-OFF
SW2	ON-OFF
SW3	ON-OFF
SW4	ON-OFF
S4	ON-OFF

FOR SETTING NETADDRESS

CODE	NETADDRESS	FACTORY SETTING
S1+S2	0~15	✓
	16~31	
	32~47	
	48~63	

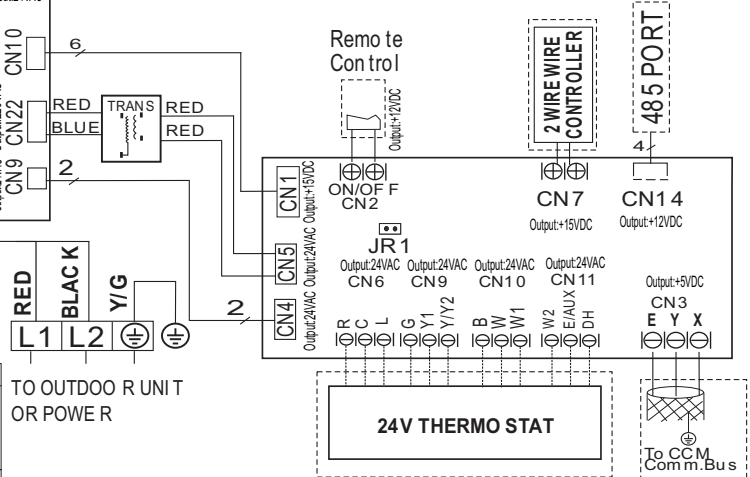

Fig. 16 — Wiring Diagram Sizes All Models

Table 12 — Wiring Diagram - All Models

CODE	CODE2	INDOOR UNIT MAINBOARD CONNECTION
CN5	5	output: 0-5VDC for water level switch connection
CN6	6	output: 5VDC for T2A, T2B (Temperature sensor)
CN9	9	output: 24VAC for 24V Interface
CN10	10	communication: 15VDC for 24V Interface
CN11	11	input: 230VAC High voltage
CN12	12	output: 24VAC for Heaters
CN15	15	output: 220VAC for ECM motor (fan)
CN18	18	output: 0V connection to ground
CN20	20	communication: 230VAC High voltage
CN22	22	output: 220VAC High voltage to transformer
CN29	29	output: 5VDC for T2 (Temperature sensor)
CN33	33	output: Normally open dry contact
CN34	34	output: 12VDC for ECM motor control
CN36	36	output: 0V for work
CN46	46	output: 5VDC for T1 (Temperature sensor)

A220919

GUIDE SPECIFICATIONS

INDOOR AIR HANDLER SYSTEMS

Size Range: 1.5 to 5 Ton Nominal Cooling and Heating Capacity Model
Number: **DLFUAA**

Part 1 - GENERAL

1.01 System Description

Indoor, air handler, direct-expansion fan coils are matched with a heat pump outdoor unit.

1.02 Agency Listings

Unit is rated per AHRI Standards 210/240 and listed in the AHRI directory as a matched system.

1.03 Delivery, Storage, And Handling

Units are stored and handled per the unit manufacturer's recommendations.

1.04 Warranty (For Inclusion By Specifying Engineer)

Part 2 - PRODUCTS

2.01 Equipment

A. General:

Indoor, direct-expansion, ceiling-mounted fan coil. The unit is complete with cooling/heating coil, fan, fan motor, piping connectors, electrical controls, microprocessor control system, and integral temperature sensing.

B. Unit Cabinet:

Unit cabinet is constructed of galvanized steel. The cabinet is fully insulated for improved thermal and acoustic performance.

C. Fans:

The fan is the tangential direct-drive blower type with air intake at the rear or bottom of the unit and discharge at the front.

D. Coil:

The coil is a copper tube with aluminum fins and galvanized steel tube sheets. The fins are bonded to the tubes by mechanical expansion and specially hydrophilic pre-coated for enhanced wet-ability. A drip pan under the coil has a drain connection for piping attachment to remove condensate.

E. Motors:

The motors have an open drip-proof, permanently lubricated ball bearing with inherent overload protection. Fan motors are 4-speed.

F. Controls:

The controls consist of a microprocessor-based control system which controls the space temperature, determines optimum fan speed, and runs self diagnostics.

The unit has the following functions (at a minimum):

1. An automatic restart, after a power failure, which sets the unit back to the same operating conditions it operated under at time of failure.
2. A timer function to provide a minimum 24-hour timer cycle for system Auto Start/Stop.
3. Automatic airflow technology - fan maintains set CFM range at up to 0.80" W.C. ESP
4. Temperature-sensing controls sense return air temperature.
5. Indoor coil freeze protection.
6. Wired remote controller to enter set points and operating conditions.
7. **DEHUMIDIFICATION** mode provides increased latent removal capability by modulating system operation and set point temperature. Applicable **only** with third party thermostats that have the dehumidification option.
8. **FAN-ONLY** operation to provide room air circulation when cooling is not required.
9. Diagnostics provide continuous checks of unit operation and warns of possible malfunctions. Error messages appear on the unit.
10. The fan speed control is user-selectable*: high, medium, low, or microprocessor controlled automatic operation during all operating modes.
11. Automatic heating-to-cooling changeover in the **HEAT** pump mode. The control includes dead-band to prevent rapid mode cycling between heating and cooling.
12. Indoor coil high temperature protection is provided to detect an excessive indoor discharge temperature when the unit is in the **HEAT** pump mode.

G. Electrical Requirements:

The indoor fan motor operates on 208-230V.

H. Operating Characteristics:

The air handler system has a minimum SEER2 (Seasonal Energy Efficiency Ratio) and HSPF2 at AHRI conditions, as listed on the specifications table.

I. Refrigerant Lines:

All units have refrigerant lines that can be oriented to connect from the side of the unit.

* Only with wired controller KSACN1001 (Sold separately)



Viessmann Manufacturing Company (U.S.) Inc.
 45 Access Road
 Warwick, Rhode Island · 02886 · USA
 TechInfo Line 1-888-484-8643
 1-800-288-0667 · Fax (401) 732-0590
 www.viessmann-us.com · info@viessmann-us.com

Viessmann Manufacturing Company Inc.
 750 McMurray Road
 Waterloo, Ontario · N2V 2G5 · Canada
 TechInfo Line 1-888-484-8643
 1-800-387-7373 · Fax (519) 885-0887
 www.viessmann.ca · info@viessmann.ca

