

Installation and service instructions

for contractors

VIESSMANN

Vitodens 100-W

Type B1HA, B1KA, 6.5 to 35.0 kW

Wall mounted gas condensing boiler

Natural gas and LPG version

Gas Council Number: 41-819-36 - 39, 47-819-33 - 35

For applicability, see the last page



VITODENS 100-W



Safety instructions



Please follow these safety instructions closely to prevent accidents and material losses.

Safety instructions explained



Danger

This symbol warns against the risk of injury.



Please note

This symbol warns against the risk of material losses and environmental pollution.

Note

Details identified by the word "Note" contain additional information.

Target group

These instructions are exclusively intended for authorised contractors.

- Work on gas installations must only be carried out by a registered gas fitter.
- Work on electrical equipment must only be carried out by a qualified electrician.
- The system must be commissioned by the system installer or a qualified person authorised by the installer.

Regulations to be observed

- National installation regulations
- Statutory regulations for the prevention of accidents
- Statutory regulations for environmental protection

- Codes of practice of the relevant trade associations
- All current safety regulations as defined by DIN, EN, DVGW, TRGI, TRF, VDE and all locally applicable standards
 - Ⓐ ÖNORM, EN, ÖVGW-TR Gas, ÖVGW-TRF and ÖVE
 - ⒸH SEV, SUVA, SVGW, SVTI, SWKI, VKF and EKAS guideline 1942: LPG, part 2

Safety instructions for working on the system

Working on the system

- Where gas is used as the fuel, close the main gas shut-off valve and safeguard it against unintentional reopening.
- Isolate the system from the power supply, e.g. by removing the separate fuse or by means of a mains isolator, and check that it is no longer 'live'.
- Safeguard the system against reconnection.



Danger

Hot surfaces can cause burns.

- Before maintenance and service work, switch OFF the appliance and let it cool down.
- Never touch hot surfaces on the boiler, burner, flue system or pipework.

Safety instructions (cont.)



Please note

Electronic assemblies can be damaged by electrostatic discharge.

Prior to commencing work, touch earthed objects such as heating or water pipes to discharge static loads.

Repair work



Please note

Repairing components that fulfil a safety function can compromise the safe operation of the system.

Replace faulty components only with genuine Viessmann spare parts.

Auxiliary components, spare and wearing parts



Please note

Spare and wearing parts that have not been tested together with the system can compromise its function. Installing non-authorised components and making non-approved modifications or conversions can compromise safety and may invalidate our warranty.

For replacements, use only original spare parts supplied or approved by Viessmann.

Safety instructions for operating the system

If you smell gas



Danger

Escaping gas can lead to explosions which may result in serious injury.

- Never smoke. Prevent naked flames and sparks. Never switch lights or electrical appliances on or off.
- Close the gas shut-off valve.
- Open windows and doors.
- Evacuate any people from the danger zone.
- Notify your gas or electricity supply utility from outside the building.
- Have the power supply to the building shut off from a safe place (outside the building).

If you smell flue gas



Danger

Flue gas can lead to life threatening poisoning.

- Shut down the heating system.
- Ventilate the installation site.
- Close doors to living spaces to prevent flue gases from spreading.

Safety instructions (cont.)

What to do if water escapes from the appliance



Danger

When water escapes from the appliance there is a risk of electrocution.

Switch off the heating system by means of an external isolator (for example fuse box, domestic power distribution).



Danger

The simultaneous operation of the boiler and appliances that extract air to the outside can result in life threatening poisoning due to reverse flow of the flue gas.

Fit an interlock circuit or take suitable steps to ensure an adequate supply of combustion air.

Flue systems and combustion air

Ensure that flue systems are clear and cannot be sealed, for instance due to accumulation of condensate or other causes. Ensure an adequate supply of combustion air.

Instruct system users that subsequent modifications to the building characteristics are not permissible (e.g. cable/pipe-work routing, cladding or partitions).



Danger

Leaking or blocked flue systems, or an inadequate supply of combustion air can cause life threatening poisoning from carbon monoxide in the flue gas.

Ensure the flue system is in good working order. Apertures for supplying combustion air must be non-closable.

Extractors

Operating appliances that extract air to the outside (cooker hoods, extractors, air conditioning units, etc.) can create negative pressure. If the boiler is operated at the same time, this can lead to reverse flow of the flue gas.

Index

Installation instructions

Information

Disposal of packaging.....	7
Symbols.....	8
Intended use.....	9
Product information.....	9

Preparing for installation.....	11
--	-----------

Installation sequence

Mounting the boiler and making the connections.....	14
Opening the control unit enclosure.....	20
Electrical connections.....	21

Service instructions

Commissioning, inspection, maintenance

Steps - commissioning, inspection and maintenance.....	28
Further details regarding the individual steps.....	30

Troubleshooting

Function sequence and possible faults.....	61
Fault display.....	62
Repairs.....	66

Gas type conversion

Converting from LPG to natural gas.....	76
---	----

Control unit

Functions and operating conditions in weather-compensated mode.....	78
---	----

Designs

Connection and wiring diagram.....	79
------------------------------------	----

Parts lists

Ordering parts.....	81
Overview of assemblies.....	82
Sheet metal parts assembly.....	83
Heat cell assembly.....	85
Burner assembly.....	87
Hydraulic assembly.....	89
Hydraulic assembly, system boiler.....	91
Hydraulic assembly, combi boiler.....	92

Index (cont.)

Control unit assembly..... 94
Miscellaneous..... 95

Specification..... 97

Disposal
Final decommissioning and disposal..... 99









Certificates
Declaration of conformity..... 100

Keyword index..... 101

Disposal of packaging

Please dispose of waste packaging in line with statutory regulations.

Symbols

Sym- bol	Meaning
	Reference to other document containing further information
	Step in a diagram: The numbers correspond to the order in which the steps are carried out.
	Warning of material losses and environmental pollution
	Live electrical area
	Pay particular attention.
	<ul style="list-style-type: none"> ■ Component must audibly click into place. or ■ Acoustic signal
	<ul style="list-style-type: none"> ■ Fit new component. or ■ In conjunction with a tool: Clean the surface.
	Dispose of component correctly.
	Dispose of component at a suitable collection point. Do not dispose of component in domestic waste.

Intended use

The appliance is only intended to be installed and operated in sealed unvented heating systems that comply with EN 12828, with due attention paid to the associated installation, service and operating instructions. It is only designed for the heating of water that is of potable water quality.

Intended use presupposes that a fixed installation in conjunction with permissible, system-specific components has been carried out.

Commercial or industrial usage for a purpose other than heating the building or DHW shall be deemed inappropriate.

Any usage beyond this must be approved by the manufacturer in each individual case.

Incorrect usage or operation of the appliance (e.g. the appliance being opened by the system user) is prohibited and will result in an exclusion of liability. Incorrect usage also occurs if the components in the heating system are modified from their intended use (e.g. if the flue gas and ventilation air paths are sealed).

Product information

Vitodens 100-W, type B1HA, B1KA

Preset for operation with natural gas. Conversion to LPG P requires a gas conversion kit.

Conversion for other countries

The Vitodens 100-W must only be delivered to the countries specified on the type plate. For deliveries to alternative countries, an approved contractor must arrange individual approval on his/her own initiative and in accordance with the law of the country in question.

Product description

The Vitodens 100-W is available as a gas condensing boiler for the connection of one DHW cylinder and as a gas condensing combi boiler with an integral plate heat exchanger for DHW heating. For the connection of heating circuits and the DHW cylinder or the DHW line, see from page 13.

In the delivered condition, the Vitodens 100-W is set up for operation with constant boiler water temperature. By connecting an outside temperature sensor (accessories), the boiler can be operated in weather-compensated mode.

Product information (cont.)

The following are integrated: one sealed unvented hydraulic system with 2 connections for heating flow and return, and 2 connections for cylinder heating (gas condensing boiler) or DHW heating (gas condensing combi boiler).

These boilers are only intended for installation in sealed unvented heating systems. Boilers for open vented heating systems are also available.

If the Vitodens 100-W is installed in an S plan or Y plan system, the DHW primary connections are not used and must be capped off.

The following components are integrated into the hydraulic system:

- Circulation pump
- 3-way diverter valve
- Safety valve
- Diaphragm expansion vessel
- Plate heat exchanger for DHW heating (gas condensing combi boiler)

DHW heating with DHW cylinder

If a Viessmann Vitocell is connected, a cylinder temperature sensor will issue the heat demand (accessories). The cylinder temperature sensor is connected to the boiler control unit. A 230 V cylinder temperature controller is not required.

If a different DHW cylinder is connected, the cylinder temperature sensor (accessories) may also be used on this cylinder. Alternatively, a 230 V cylinder temperature controller should be connected via the cylinder demand junction box (part of the boiler standard delivery).

Connecting accessories

Cylinder temperature sensor, outside temperature sensor and time switch are connected to the control unit with low voltage.

Preparing for installation

Preparing for boiler installation

Dimensions and connections

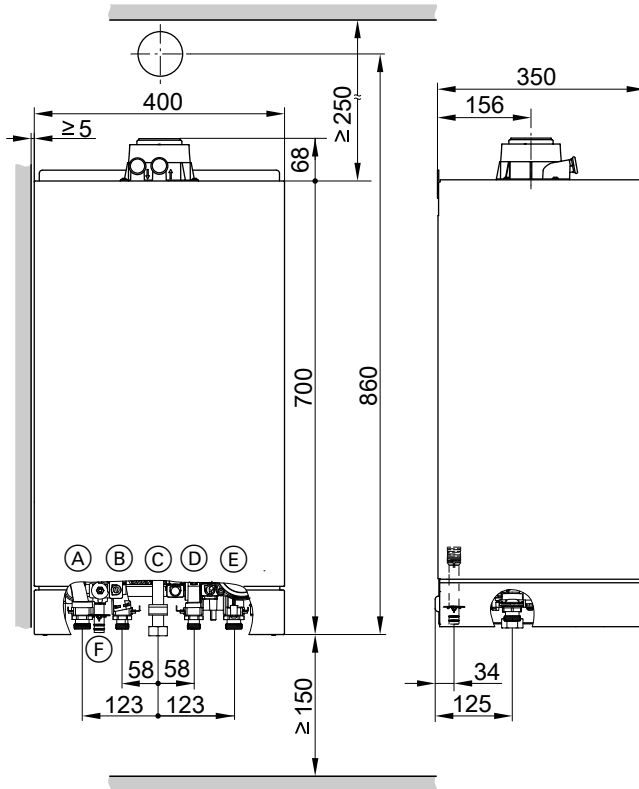

- (A) Heating flow
 - (B) Gas condensing boiler:
Cylinder flow
 - (C) Gas connection
 - (D) Gas condensing boiler:
Cylinder return
 - (E) Heating return
 - (F) Condensate drain/ drain safety
valve: Plastic hose \varnothing 22 mm
- Gas condensing combi boiler:
DHW
- Gas condensing combi boiler:
Cold water

Preparing for installation (cont.)

Fitting the wall mounting bracket

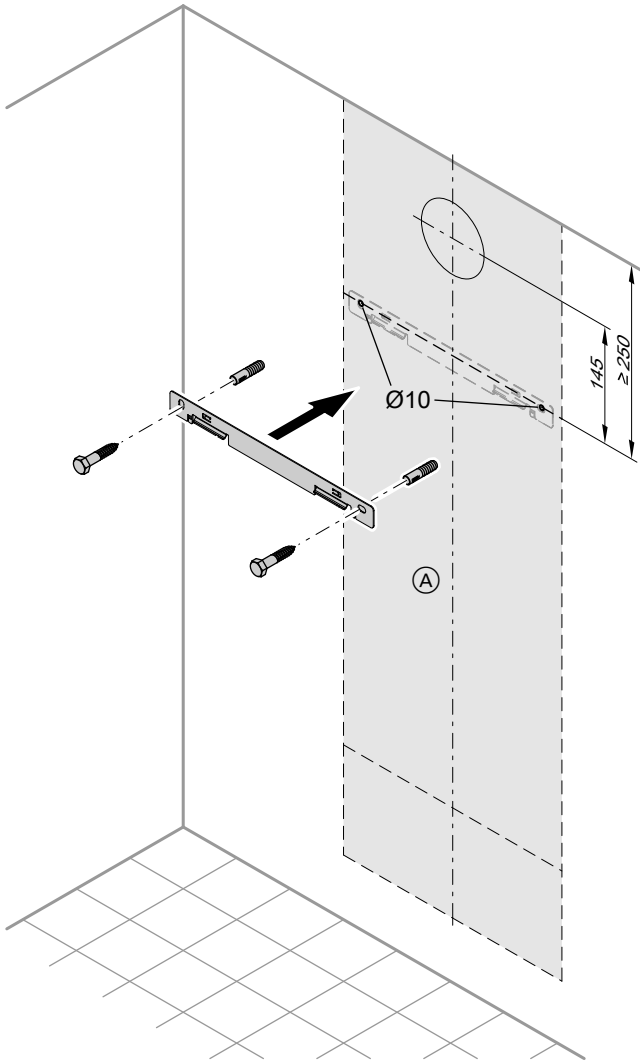

(A) Vitodens installation template

1. Position the supplied installation template on the wall.
2. Mark out the rawl plug holes.

Preparing for installation (cont.)

3. Drill \varnothing 10 mm holes and insert the rawl plugs supplied.
4. Fit wall mounting bracket with screws supplied.

Fitting the pre-plumbing jig or mounting frame



Pre-plumbing jig or mounting frame installation instructions

Preparing the connections



Please note

To prevent appliance damage, connect all pipework free of load and torque stress.

1. Prepare the water connections. Flush the heating system.
2. Prepare the gas connection.
3. Prepare the electrical connections.
 - Power cable:
Flexible cable 3 x 1.5 mm²
Leave the earth conductor (PE) longer than the 'live' conductors L1 and N.
 - Accessory cables:
NYM-O 2-core min. 0.5 mm².

Mounting the boiler and making the connections

Removing the front panel and mounting the boiler

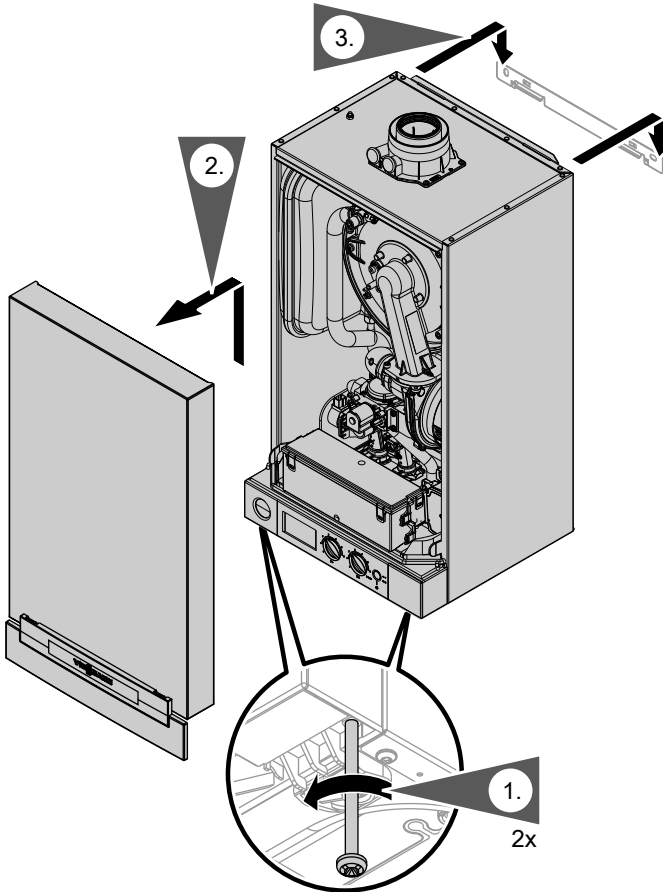

1. Undo the screws at the bottom of the boiler; do not remove completely.
2. Remove the front panel.
3. Hook the boiler onto the wall mounting bracket.

Mounting the boiler and making the connections (cont.)

Making the connections on the water side



For installation of fittings on the heating water side and DHW side, see separate installation instructions.

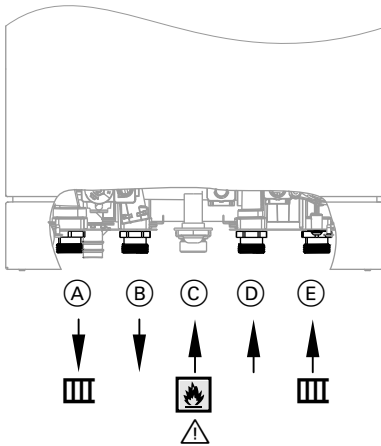

- (A) Heating flow
- (B) Gas condensing boiler:
Cylinder flow
Gas condensing combi boiler:
DHW
- (C) Gas connection
- (D) Gas condensing boiler:
Cylinder return
Gas condensing combi boiler:
Cold water
- (E) Heating return

Gas condensing boiler

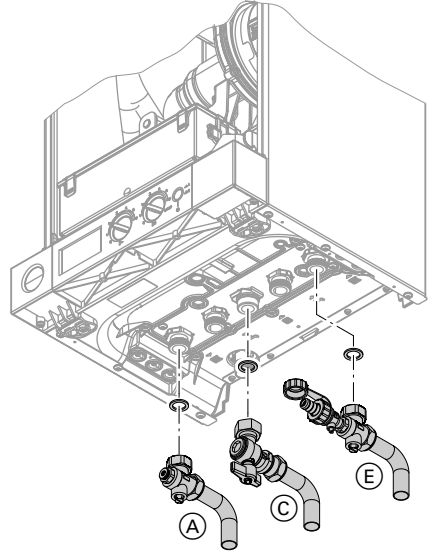

Mounting the boiler and making the connections (cont.)

Gas condensing combi boiler

Permiss. DHW operating pressure:
10 bar (1.0 MPa)

Note

Install a pressure reducer if required.

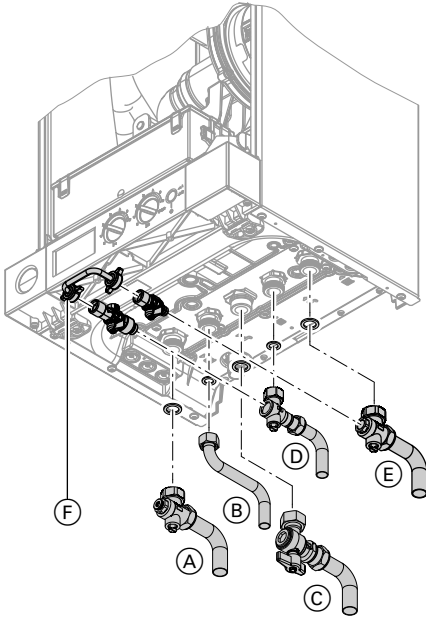

(F) Filling loop

Gas connection

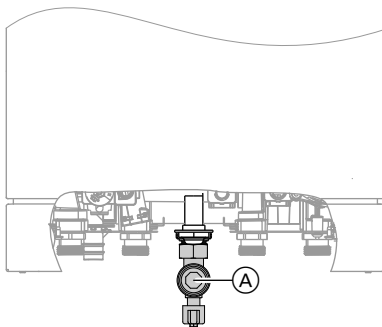

1. Connect gas shut-off valve to connection (A).

Mounting the boiler and making the connections (cont.)

2. Carry out a tightness test.

Note

Only use suitable and approved leak detection agents (EN 14291) and devices for the tightness test. Leak detection agents with unsuitable constituents (e.g. nitrides, sulphides) can result in material damage. Remove leak detection agent residues after testing.

**Please note**

Excessive test pressure will damage the boiler and the gas train.

Max. test pressure 150 mbar. If a higher pressure is required for tightness tests, disconnect the boiler and the gas train from the main supply pipe (undo the fitting).

3. Purge the gas line.

Mounting the boiler and making the connections (cont.)

Connecting the safety valve and condensate drain

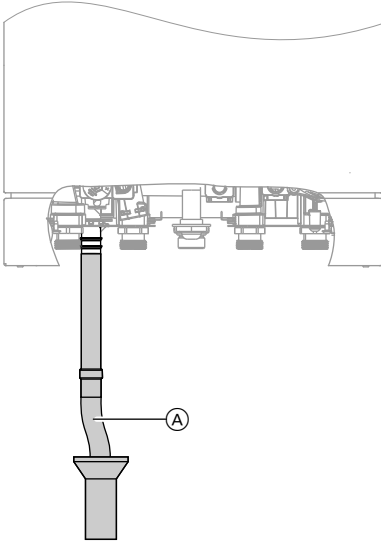

- The condensate pipe is connected to the discharge pipe of the safety valve. The supplied condensate hose meets the temperature requirements for CE certification.
- We recommend connecting the condensate pipe to the internal domestic waste water system, either directly or via a tundish.

- If the condensate pipe is routed outside the building, use a pipe with at least \varnothing 30 mm and protect this pipe from frost. Avoid long external pipe runs.



Please note

A frozen condensate pipe can result in faults and damage to the boiler.
Always protect condensate pipes against frost.

- Observe local building regulations. Connect condensate pipe (A) to the public sewage system with a constant fall and a pipe vent. Observe the local waste water regulations.

Note

Fill the trap with water before commissioning.

Mounting the boiler and making the connections (cont.)

Filling the trap with water

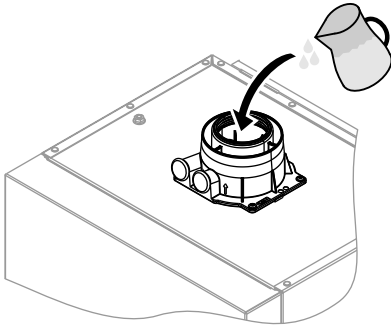

Pour at least 0.3 l of water into the flue outlet.



Please note

During commissioning, flue gas may escape from the condensate drain.

Always fill the trap with water before commissioning.

Balanced flue connection

Note

Only use the "System certificate" and "Skoberne GmbH flue system" labels in conjunction with the Viessmann flue system made by Skoberne.

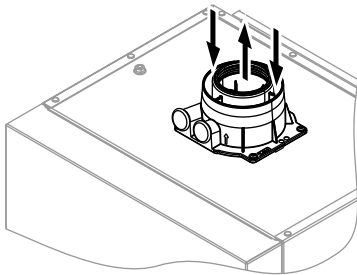

Connect the balanced flue.

During installation and positioning of the flue system, observe Building regulations Part L and BS 5440.



Flue system installation instructions.

Connecting several Vitodens 100-W to a shared flue system

Adjust the burner setting of each connected boiler to match the flue system:

- For shared connection, see page 40.
- For flue gas cascade, see page 47.

Do not carry out **commissioning** until the following conditions are met:

- Free passage through the flue gas pipes.
- Flue system with positive pressure is gas-tight.

Mounting the boiler and making the connections (cont.)

- Apertures for ensuring sufficient combustion air supply are open and cannot be closed off.
- Applicable regulations on installing and commissioning flue systems have been followed.



Danger

Leaking or blocked flue systems or an insufficient supply of combustion air cause life threatening poisoning due to carbon monoxide in the flue gas. Ensure the flue system functions correctly. Apertures for combustion air supply must not be able to be closed off.

Opening the control unit enclosure

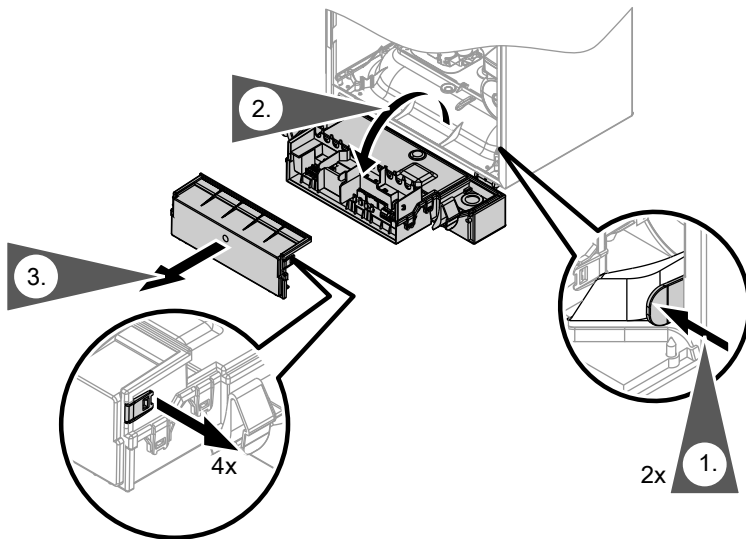

Opening the control unit enclosure (cont.)



Please note

Electronic assemblies can be damaged by electrostatic discharge.

Prior to commencing any work, touch earthed objects such as heating or water pipes to discharge static loads.

Electrical connections

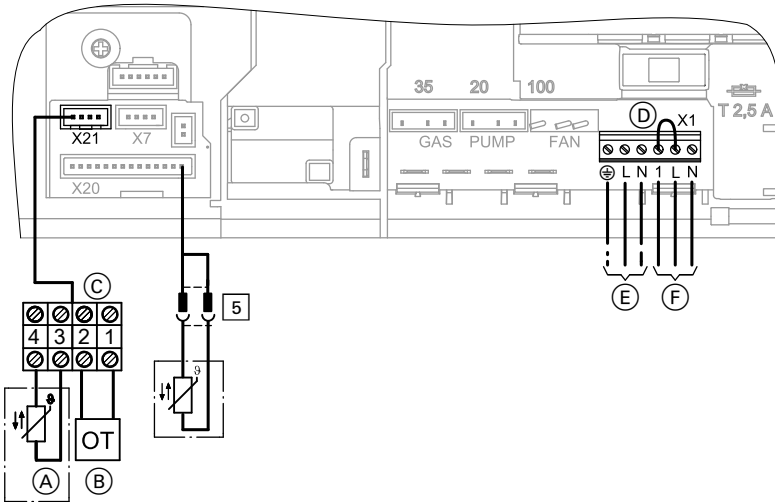

Electrical connections (cont.)

- 5 Gas condensing boiler:
- For Viessmann DHW cylinders:
Cylinder temperature sensor (plug on the cable harness outside the control unit)
 - In the case of alternative DHW cylinders compliant with the G3 Directive:
Cylinder demand junction box (for connection of a cylinder temperature controller and a 2-way shut-off valve)
 - Without DHW cylinder:
For operation without a DHW cylinder, set rotary selector "🔌🔌" to "0".
- (A) Only for weather-compensated mode:
Outside temperature sensor (accessories)
- (B) OpenTherm device
Remove jumper (D) when making this connection.
- (C) Connecting cable
- (D) Jumper
- (E) Power supply (230 V, 50 Hz).
See page 26.
- (F) Vitotrol 100 or on-site room temperature controller (230 V switched input)
Remove jumper (D) when making this connection.



Separate installation instructions



Information on connecting accessories

When connecting accessories observe the separate installation instructions provided with them.

Electrical connections (cont.)

Connection of room temperature controller and DHW cylinder with 230 V cylinder temperature controller

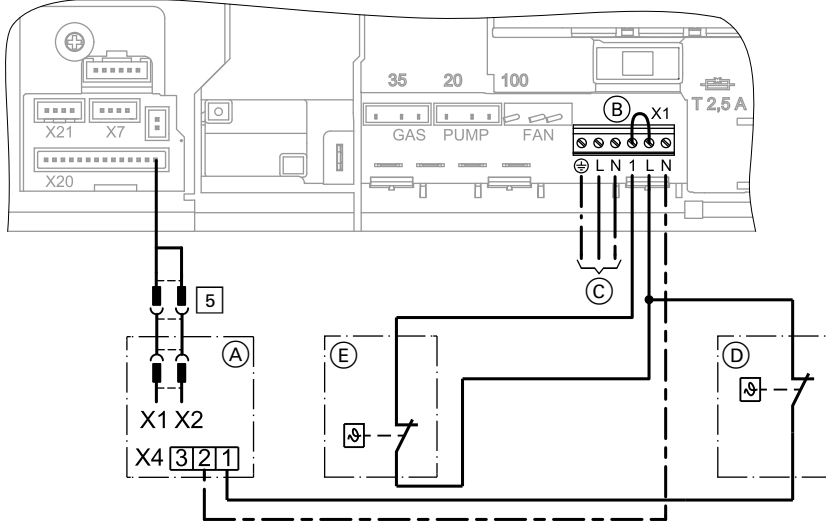

- (A) Cylinder demand junction box
- (B) Jumper, remove when making this connection
- (C) Power supply (230 V, 50 Hz). See page 26.
- (D) 230 V cylinder temperature controller
- (E) Room temperature controller

Electrical connections (cont.)

Connection of room temperature controller with time switch and DHW cylinder with 2-way valve and 230 V cylinder temperature controller

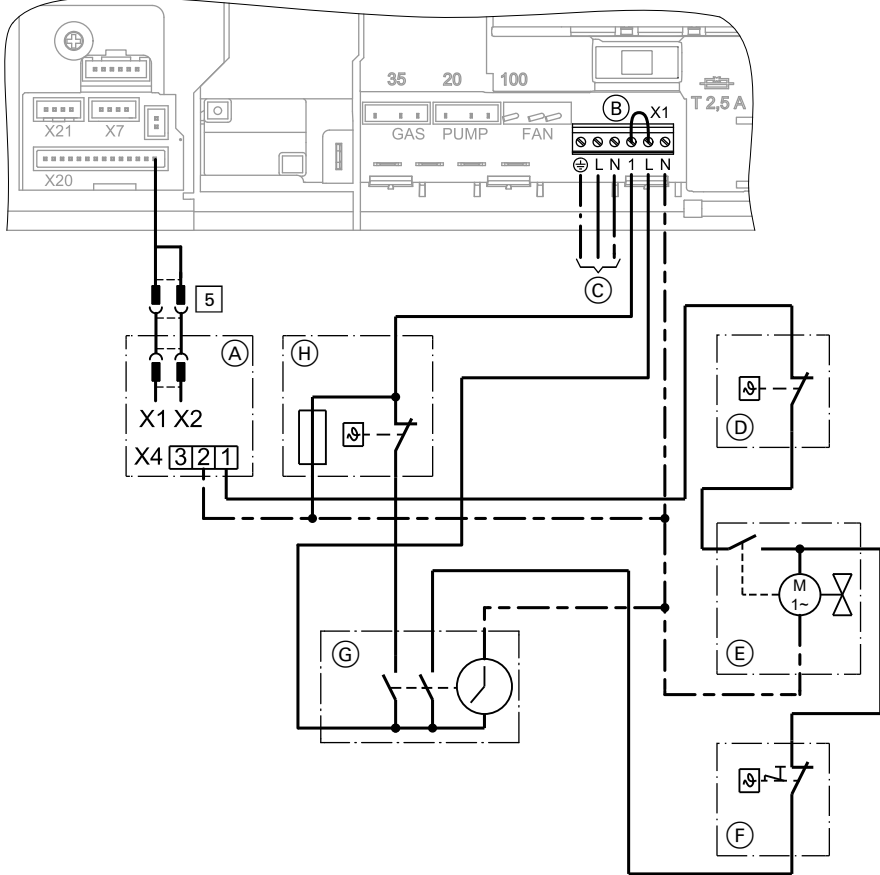

- | | |
|--|---------------------------------|
| (A) Cylinder demand junction box | (E) 2-way shut-off valve |
| (B) Jumper, remove when making this connection | (F) High limit safety cut-out |
| (C) Power supply (230 V, 50 Hz).
See page 26. | (G) Time switch |
| (D) 230 V cylinder temperature controller | (H) Room temperature controller |

Electrical connections (cont.)

Cable entry

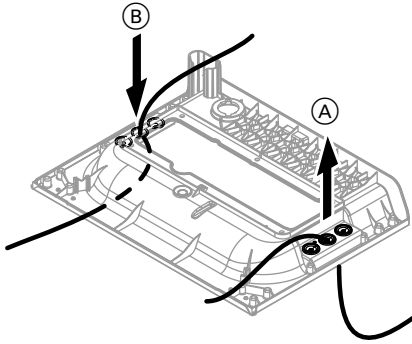

- (A) Power cable, remote control connecting cable
- (B) LV leads (sensor leads)

Outside temperature sensor (accessories)

1. Fit outside temperature sensor.
2. Connect the outside temperature sensor to terminals 3 and 4 of the power cable (see page 21).

Installation site:

- North or north-westerly wall, 2 to 2.5 m above ground level; in multi storey buildings, in the upper half of the 2nd floor
- Not above windows, doors or vents
- Not immediately below balconies or gutters
- Never render over
- Connection:
2-core lead, length up to 35 m with 1.5 mm² cross-section

Electrical connections (cont.)

Vitotrol 100 connection (accessories)

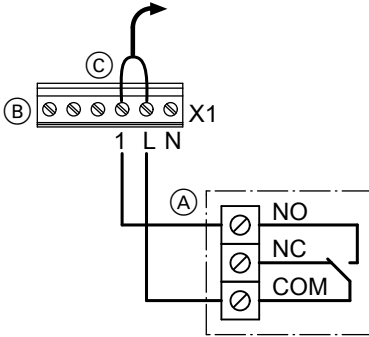

Example: Vitotrol 100, type UTDB

- (A) Vitotrol 100, type UTDB
- (B) Terminals "X1" on the control unit
- (C) Jumper, remove when making this connection

Recommended connecting cable

- 2-core cable with 1.5 mm² cross-section for 230 V~

Power supply

Regulations and directives





Danger

Incorrectly executed electrical installations can result in injuries from electrical current and in appliance damage.

Connect the power supply and implement all safety measures (e.g. RCD circuit) in accordance with the following regulations:

- IEC 60364-4-41
- VDE regulations
- Connection requirements specified by your local power supply utility

Install an isolator in the power cable that simultaneously isolates all non-earthed conductors from the power supply with at least 3 mm contact separation.

We also recommend installing an AC/DC-sensitive RCD (RCD class B  ) for DC (fault) currents that can occur with energy efficient equipment.

Protect the power cable with an external 3 A fuse to BS 1362.

Electrical connections (cont.)



Danger

Incorrect core assignment can result in serious injury and damage to the appliance. Take care **not** to interchange cores "L1" and "N".



Danger

The absence of component earthing can lead to serious injury from electric current if an electrical fault occurs. The appliance and pipework must be connected to the equipotential bonding of the building.

Routing connecting cables and closing the control unit enclosure



Please note

Connecting cables will be damaged if they touch hot components.

When routing and securing cables/leads on site, ensure that the maximum permissible temperature for these cables/leads is not exceeded.

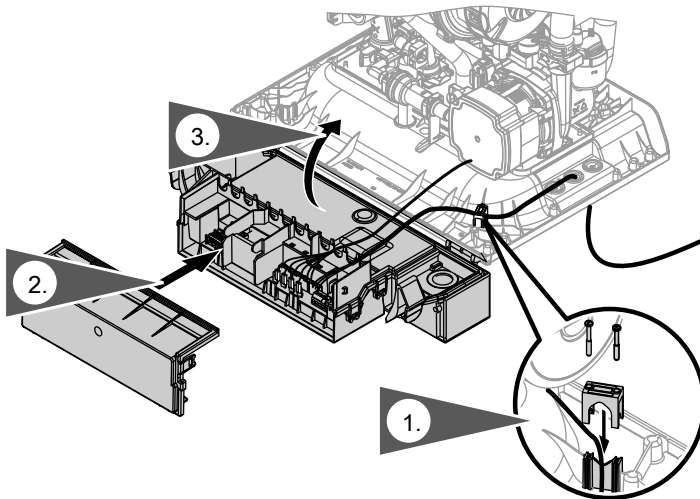

Steps - commissioning, inspection and maintenance

For further information regarding the individual steps, see the page indicated

				Page
			Commissioning steps	
			Inspection steps	
			Maintenance steps	
•	•	•	1. Filling the heating system.....	30
•	•	•	2. Venting the boiler by flushing.....	32
•	•	•	3. Converting to operation with LPG.....	33
•	•	•	4. Checking the static and supply pressure.....	34
•			5. Reducing the maximum heating output.....	35
•			6. Adjusting the circulation pump rate to the heating system.....	37
•			7. Burner adjustment when connecting multiple flues to a shared flue system.....	39
•			8. Adjust the burner setting if several boilers are connected to a shared flue (flue gas cascade).....	47
•			9. Checking the CO₂ content.....	50
	•	•	10. Burner removal	53
	•	•	11. Checking the burner gasket and burner gauze assembly.....	54
	•	•	12. Checking and adjusting the electrode.....	55
	•	•	13. Cleaning the heat exchanger.....	55
	•	•	14. Checking the condensate drain and cleaning the trap	56
	•	•	15. Installing the burner	57
	•	•	16. Checking the diaphragm expansion vessel and system pressure.....	58
•	•	•	17. Checking the connections on the heating water and the DHW side.....	58
•	•	•	18. Checking flue system for unrestricted flow and tightness	
•	•	•	19. Checking firm seating of electrical connections	

Steps - commissioning, inspection and... (cont.)

	Commissioning steps		
	Inspection steps		
	Maintenance steps		
			Page
•		20. Checking all gas equipment for tightness at operating pressure	59
•		21. Fitting the front panel.....	59
•		22. Instructing the system user.....	60

Further details regarding the individual steps

Filling the heating system



Please note

Unsuitable fill water increases the level of deposits and corrosion and may lead to boiler damage.

- Flush the heating system thoroughly before filling.
- Only fill with water of potable quality.

- Soften fill water with a hardness above 300 ppm.
- Antifreeze suitable for heating systems can be added to the fill water.

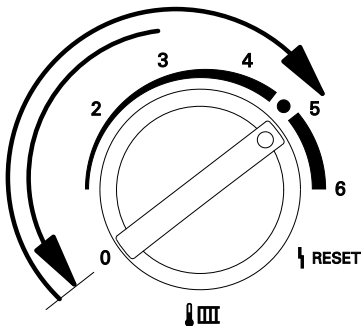

1. Close the gas shut-off valve.
2. Switch ON the power supply.
3. Turn rotary selector "III" anticlockwise for less than 2 s and then clockwise back into the r. h. section of the control range. "SERV", "III" and "⚡" will appear on the display. Filling function is enabled. This function terminates automatically after 20 min or when the ON/OFF switch is switched off.

Further details regarding the individual steps (cont.)

Gas condensing boiler

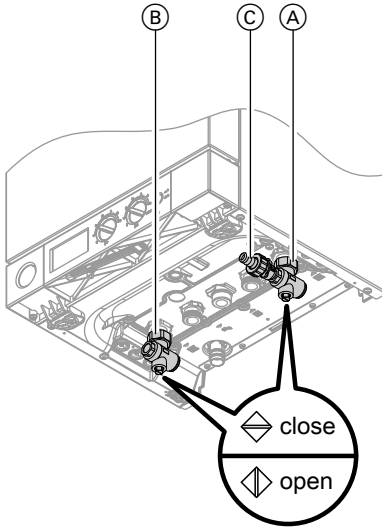

1. Open shut-off valves (A) and (if fitted) (B).
2. Connect fill hose to valve (C) and open valve (C).
3. Fill the heating system. [a removable filling loop with double check valve must be used in UK] (system pressure 0.8 to 1.2 bar).
4. Close valve (C).

Gas condensing combi boiler

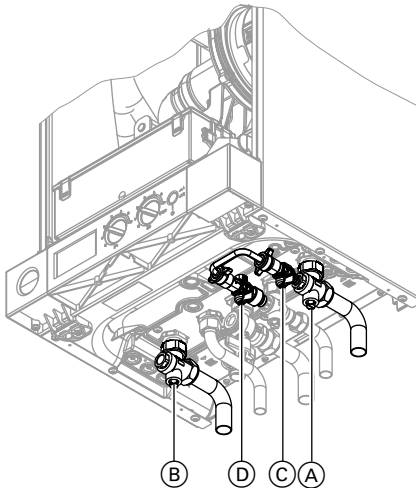

1. Open shut-off valves (A) and (if fitted) (B).
2. Open valves (C) and (D).

Note

The cold water supply must be open.

3. Fill the heating system (system pressure 0.8 to 1.2 bar).
4. Close valves (C) and (D).
5. Remove the connection line between valves (C) and (D). In operation the connection must be interrupted.

Further details regarding the individual steps (cont.)

Venting the boiler by flushing

Gas condensing boiler

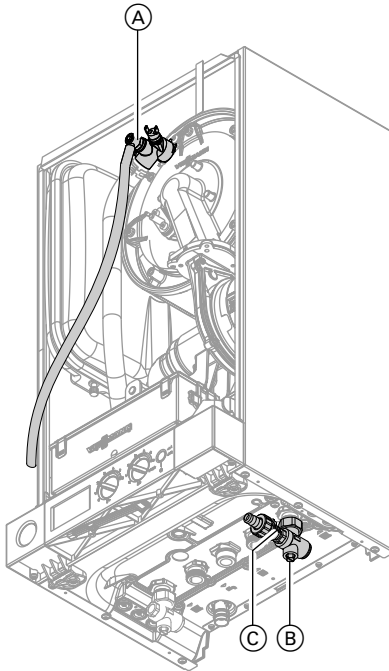

1. Connect the drain hose on shut-off valve (A) to a drain.
2. Close shut-off valve (B).
3. Open valves (A) and (C) and flush at mains pressure, until no sound of escaping air can be heard.
4. First close valve (A) and then valve (C).
5. Adjust the operating pressure ≥ 0.8 bar (80 kPa) with valve (C).
6. Open shut-off valve (B).
7. Disconnect drain hose and keep safe.

Further details regarding the individual steps (cont.)

Gas condensing boiler

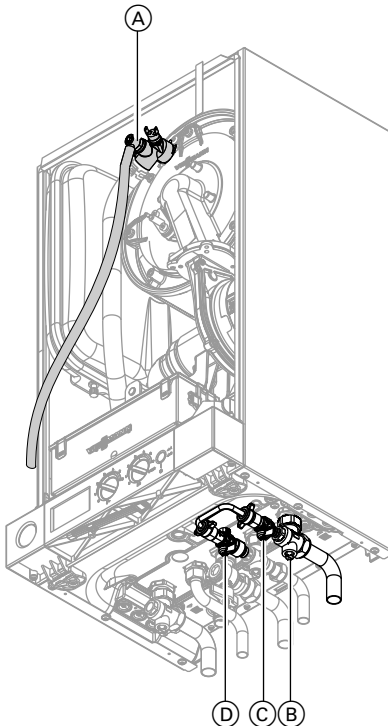

1. Connect the drain hose on shut-off valve (A) to a drain.
2. Close shut-off valve (B).
3. Open valves (A), (C) and (D) and flush at mains pressure, until no sound of escaping air can be heard.
4. First close valve (A) and then valves (C) and (D).
5. Adjust the operating pressure ≥ 0.8 bar (80 kPa) with valves (C) and (D).
6. Open shut-off valve (B).
7. Disconnect drain hose and keep safe.

Converting to operation with LPG

In the delivered condition, the boiler is set up for operation with natural gas. For operation with LPG, change the gas nozzle and switch to the correct gas type in the control unit.



Separate installation instructions.

Conversion from LPG to natural gas, see page 76.

Further details regarding the individual steps (cont.)

Checking the static and supply pressure



Danger

CO formation as a result of incorrect burner adjustment can have serious health implications. Carry out a CO test before and after work on gas appliances.

Operation with LPG

Purge the LPG tank twice during commissioning or replacement. Vent the tank and gas connection line thoroughly after purging.

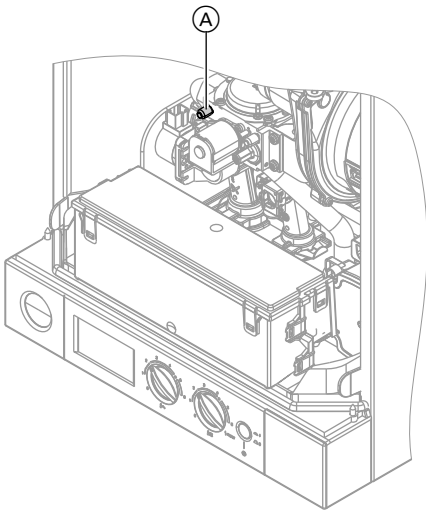

1. Close the gas shut-off valve.
2. Undo screw (A) inside test connector "IN" on the gas train but do not remove it, and connect the pressure gauge.
3. Open the gas shut-off valve.

4. Check the static pressure.
Set value: max. 57.5 mbar (5.75 kPa)

5. Start the boiler.

Note

During commissioning, the boiler can enter a fault state because of airlocks in the gas line. After approx. 5 s, press **Reset** to reset the burner.

6. Check the supply (flow) pressure.

Set value:

- Natural gas: 20 mbar (2.0 kPa)
- LPG: 37 mbar (3.7 kPa)

Note

Use a suitable tester with a resolution of at least 0.1 mbar (10 Pa) to check the supply pressure.

7. Proceed as indicated in the following table.
8. Shut down the boiler, close the gas shut-off valve and remove the pressure gauge. Close test connector (A) with the screw.

Further details regarding the individual steps (cont.)

9. Open the gas shut-off valve and start the appliance.



Danger

Gas escaping from the test connector leads to a risk of explosion.

Check gas tightness at test connector (A).

Note

The maximum pressure drop between the gas shut-off valve and test connector (A) at the gas train is 0.5 mbar (50 Pa).

Supply pressure (flow pressure)		Measures
For natural gas	For LPG	
below 17.4 mbar (1.74 kPa)	below 25 mbar (2.5 kPa)	Do not start the boiler. Notify your gas supply utility or LPG supplier.
17.4 to 25 mbar (1.74 to 2.5 kPa)	25 to 47 mbar (2.5 to 4.7 kPa)	Start the boiler.
above 25 mbar (2.5 kPa)	above 47 mbar (4.7 kPa)	Install a separate gas pressure governor upstream of the system and regulate the flow pressure to 20 mbar (2.0 kPa) for natural gas or 37 mbar (3.7 kPa) for LPG. Notify your gas supply utility or LPG supplier.

Reducing the maximum heating output

The maximum heating output can be reduced according to system requirements.

1. Switch ON the ON/OFF switch.

Further details regarding the individual steps (cont.)

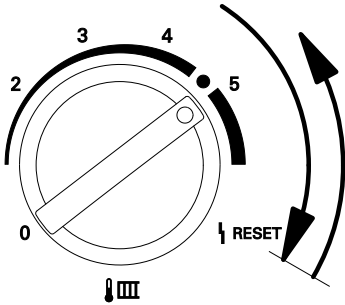

2. Turn rotary selector "🌡️ III" for less than 2 s fully clockwise and then back into the r.h. section of the control range. "SERV" and "👁️" appear on the display.

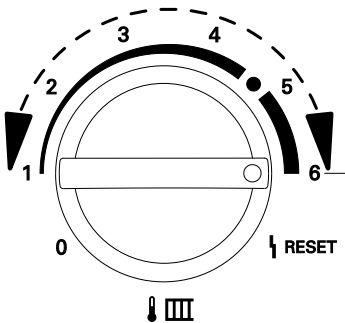

3. Select the required maximum heating output with rotary selector "🌡️ III". Bars for the selected heating output flash on the display.

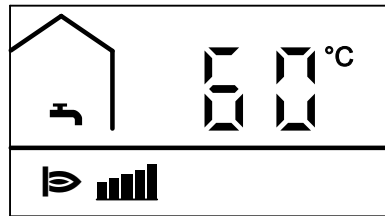

- Position 1 (1 bar) = lower heating output.
 - Position 6 (5 bars) = upper heating output.
4. Test selected heating output by checking the gas throughput.

Further details regarding the individual steps (cont.)

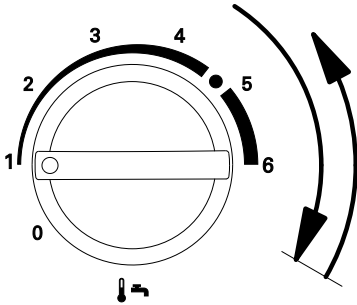

5. Accept set heating output:
Turn rotary selector "⏴⏵" for less than 2 s fully clockwise and then back into the r. h. section of the control range.
During acceptance, the display shows "- . - . -".
6. Shut down the boiler.

Adjusting the circulation pump rate to the heating system

In its delivered condition the circulation pump is set to the following pump rate:

- For DHW heating: Speed 100 %
- For heating mode without outside temperature sensor:

Rated heating output in kW	19	26	30	35
Speed in %	72	80	86	100

The speed cannot be changed.

- For heating mode with outside temperature sensor:

Rated heating output in kW	19	26	30	35
Min. speed in %	72	72	72	72
Max. speed in %	72	80	86	100

The maximum speed can be changed.
See the following chapter.

Further details regarding the individual steps (cont.)

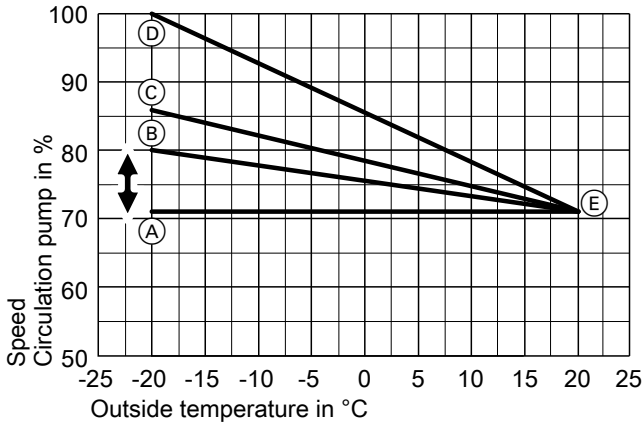

- (A) Max. speed 19 kW
- (B) Max. speed 26 kW
- (C) Max. speed 30 kW

- (D) Max. speed 35 kW
- (E) Min. speed

Changing the maximum speed

Only when operating with an outside temperature sensor.

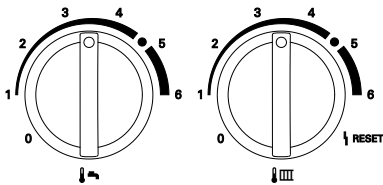

1. Switch ON the ON/OFF switch.
2. Turn both rotary selectors "🌡️➡️" and "🌡️⏏️" simultaneously to their central positions.
The display shows "SERV".

Further details regarding the individual steps (cont.)

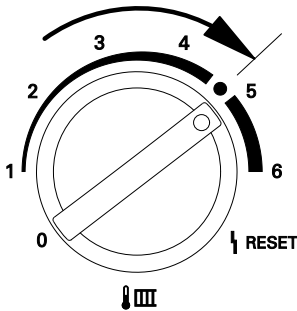

3. Within 2 s, turn rotary selector "🔥" to the top right range. "🔥" appears on the display and the set value in % of maximum speed flashes.

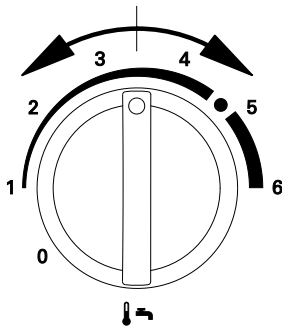

4. Change the maximum speed with rotary selector "🔥".
5. The change has been programmed when the value stops flashing. The control unit returns to standard mode.
6. Reset both rotary connectors to their required set values.

Burner adjustment when connecting multiple flues to a shared flue system

When connecting several Vitodens 100-W to a shared flue system:

Adjust the burner setting of each connected boiler by a correction factor to match it to the flue system.

System conditions:

- Shared flue in shaft \varnothing 100 mm
- Balanced flue connection line from boiler to shaft \varnothing 80/125 mm

- Minimum shaft cross-section
 - Square 175 x 175 mm
 - Round \varnothing 195 mm
- Minimum height between floors 2.5 m
- Max. 6 boilers with the same rated heating output connected to the shared flue system

Further details regarding the individual steps (cont.)

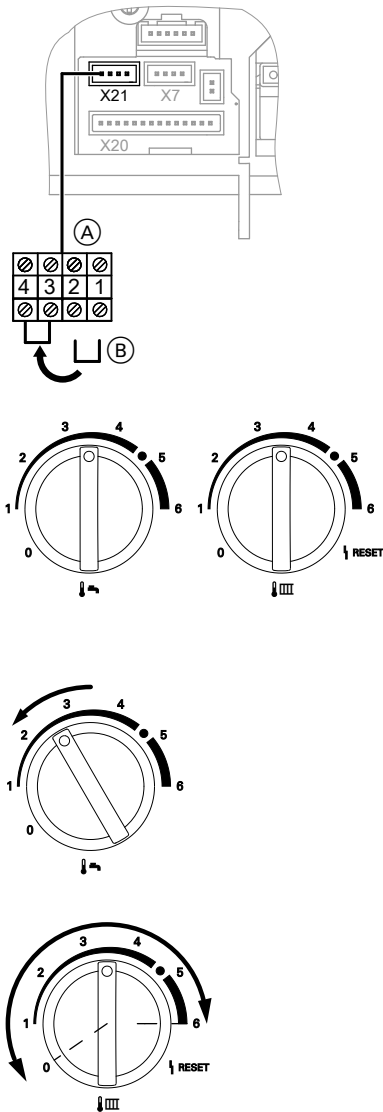

1. At terminal block (A) insert jumper (B) across terminals 3 and 4.
2. Switch ON the ON/OFF switch.
3. Turn both rotary selectors "1" and "3" simultaneously to their central positions.
The display shows "SERV".
4. Refer to the following table for the correction factor required for the flue system.
5. Within 2 s, turn rotary selector "1" to the top left range.
The display shows "III", "I>", and the selected correction factor flashes.
In the delivered condition, factor 0 has been set.
6. Within 15 s, set rotary selector "3" to the required correction factor.
7. The set correction factor is programmed when the value stops flashing, and the control unit returns to standard mode.
8. Remove jumper (B) from terminal block (A).

Further details regarding the individual steps (cont.)

One boiler per floor

Rated heating output 19 kW

Number of boilers	2	3	4	5	6
Correction factor (set value)	Flue length a (m)				
0					
1	≤ 25	≤ 12			
2	–	> 12 ≤ 25	≤ 17	≤ 14	≤ 13
3	–	–	> 17 ≤ 25	> 14 ≤ 19	> 13 ≤ 17
4	–	–	–	> 19 ≤ 24	> 17 ≤ 20
5	–	–	–	> 24 ≤ 25	> 20 ≤ 23
6	–	–	–	–	> 23 ≤ 25

Rated heating output 26 kW

Number of boilers	2	3	4	5	6
Correction factor (set value)	Flue length a (m)				
0					
1	≤ 17				
2	> 17 ≤ 25	≤ 17			
3	–	> 17 ≤ 25	≤ 17	≤ 14	≤ 13
4	–	–	> 17 ≤ 21	> 14 ≤ 17	> 13 ≤ 15
5	–	–	> 21 ≤ 25	> 17 ≤ 20	> 15 ≤ 17
6	–	–	–	> 20 ≤ 22	> 17 ≤ 19

Rated heating output 30 kW

Number of boilers	2	3	4	5	6
Correction factor (set value)	Flue length a (m)				
0					
1	≤ 13				
2	> 13 ≤ 25	≤ 14			
3	–	> 14 ≤ 21	≤ 14		
4	–	> 21 ≤ 25	> 14 ≤ 17	≤ 14	≤ 13
5	–	–	> 17 ≤ 21	> 14 ≤ 16	> 13 ≤ 15
6	–	–	> 21 ≤ 24	> 16 ≤ 18	> 15 ≤ 16

Further details regarding the individual steps (cont.)

Rated heating output 35 kW

Number of boilers	2	3	4	5	6
Correction factor (set value)	Flue length a (m)				
0					
1	≤ 10				
2	> 10 ≤ 25	≤ 11			
3	–	> 11 ≤ 17			
4	–	> 17 ≤ 22	≤ 14	≤ 13	
5	–	> 22 ≤ 25	> 14 ≤ 17	> 13 ≤ 14	≤ 13
6	–	–	> 17 ≤ 20	> 14 ≤ 16	> 13 ≤ 15

Note

The correction factor changes the boiler modulation range.

Further details regarding the individual steps (cont.)

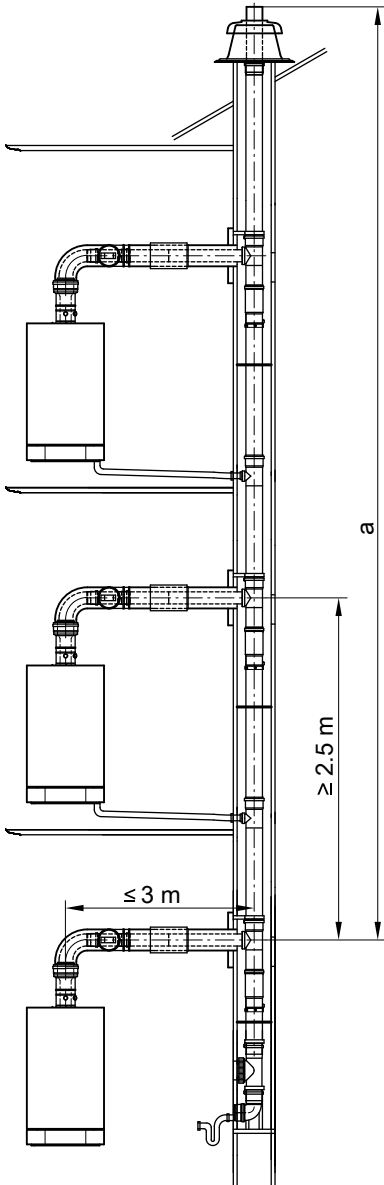

5677 216 GB

Further details regarding the individual steps (cont.)

Two boilers per floor

Rated heating output 19 kW

Number of boilers	2	4	6
Correction factor (set value)	Flue length a (m)		
0			
1	≤ 15	≤ 5	≤ 5
2	–	> 5 ≤ 12	> 5 ≤ 8
3	–	> 12 ≤ 15	> 8 ≤ 12
4	–	–	> 12 ≤ 15
5	–	–	–
6	–	–	–

Rated heating output 26 kW

Number of boilers	2	4	6
Correction factor (set value)	Flue length a (m)		
0			
1	≤ 25		
2	–	≤ 8	≤ 6
3	–	> 8 ≤ 13	> 6 ≤ 8
4	–	> 13 ≤ 15	> 8 ≤ 10
5	–	–	> 10 ≤ 12
6	–	–	> 12 ≤ 14

Rated heating output 30 kW

Number of boilers	2	4	6
Correction factor (set value)	Flue length a (m)		
0			
1	≤ 11		
2	> 11 ≤ 15	≤ 7	≤ 5
3	–	> 7 ≤ 10	> 5 ≤ 7
4	–	> 10 ≤ 14	> 7 ≤ 8
5	–	> 14 ≤ 15	> 8 ≤ 10
6	–	–	> 10 ≤ 11

Rated heating output 35 kW

Number of boilers	2	4	6
Correction factor (set value)	Flue length a (m)		
0			
1	≤ 9		
2	> 9 ≤ 15	≤ 6	≤ 5

Further details regarding the individual steps (cont.)

Number of boilers	2	4	6
Correction factor (set value)	Flue length a (m)		
3	–	$> 6 \leq 8$	$> 5 \leq 6$
4	–	$> 6 \leq 11$	$> 6 \leq 7$
5	–	$> 11 \leq 14$	$> 7 \leq 8$
6	–	$> 14 \leq 15$	$> 8 \leq 9$

Note

The correction factor changes the boiler modulation range.

Further details regarding the individual steps (cont.)

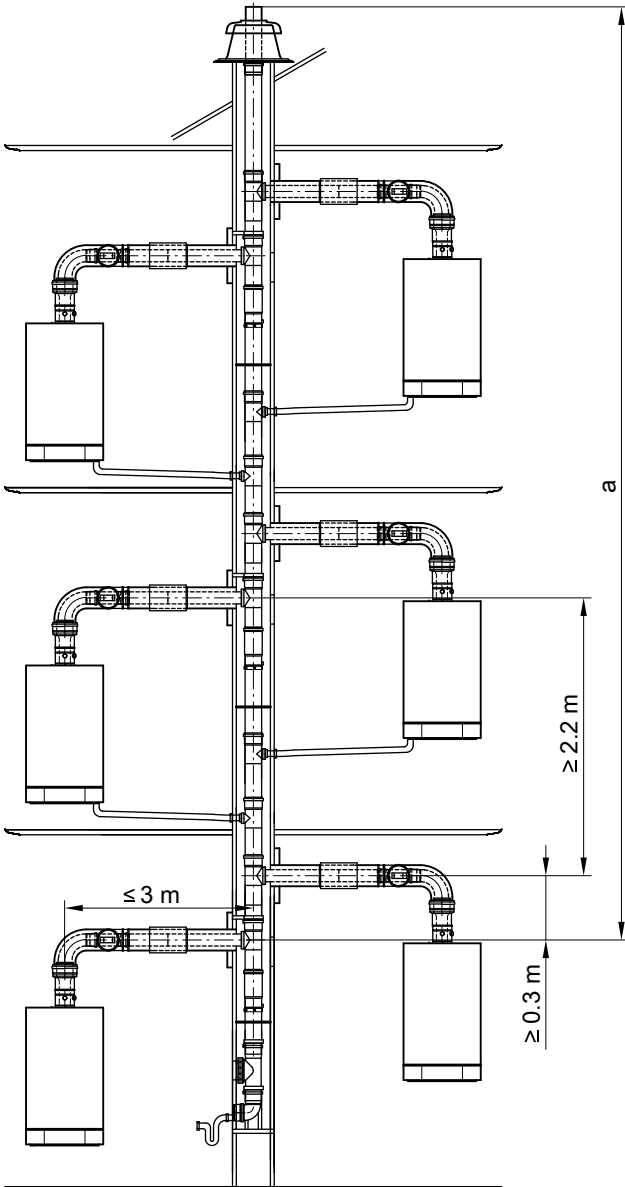

Further details regarding the individual steps (cont.)

Adjust the burner setting if several boilers are connected to a shared flue (flue gas cascade)

Adjust the burner setting of each connected boiler by a correction factor to match it to the flue system.

System conditions:

- Shared flue gas header \varnothing 100 mm
- Up to 4 boilers with the same rated heating output connected to the shared flue system

1. At terminal block (A) insert jumper (B) across terminals 3 and 4.
2. Switch ON the ON/OFF switch.

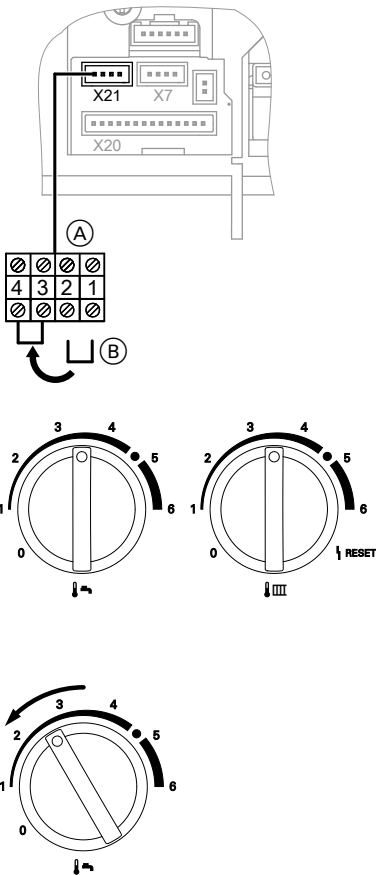

3. Turn both rotary selectors "⏏" and "III" simultaneously to their central positions.
The display shows "SERV".
4. Refer to the following table for the correction factor required for the flue system.
5. Within 2 s, turn rotary selector "⏏" to the top left range.
The display shows "III", "⏏", and the selected correction factor flashes.
In the delivered condition, factor 0 has been set.

Further details regarding the individual steps (cont.)

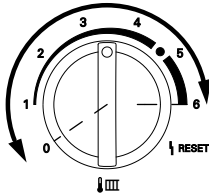

6. Within 15 s, set rotary selector "⏏" to the required correction factor.
7. The set correction factor is programmed when the value stops flashing, and the control unit returns to standard mode.
8. Remove jumper (B) from terminal block (A).

Rated heating output 19 kW

Number of boilers	2	3	4
Correction factor (set value)	Flue length a (m)		
0			
1	≤ 25	≤ 9	≤ 4
2	–	> 9 ≤ 25	> 4 ≤ 13
3	–	–	> 13 ≤ 22
4	–	–	> 22 ≤ 25
5	–	–	–
6	–	–	–

Rated heating output 26 kW

Number of boilers	2	3	4
Correction factor (set value)	Flue length a (m)		
0			
1	≤ 17	≤ 5	
2	> 17 ≤ 25	> 5 ≤ 15	≤ 7
3	–	> 15 ≤ 25	> 7 ≤ 13
4	–	–	> 13 ≤ 18
5	–	–	> 18 ≤ 24
6	–	–	> 24 ≤ 25

Rated heating output 30 kW

Number of boilers	2	3	4
Correction factor (set value)	Flue length a (m)		
0			
1	≤ 12	≤ 4	≤ 2
2	> 12 ≤ 25	> 4 ≤ 11	> 2 ≤ 5
3	–	> 11 ≤ 19	> 5 ≤ 10

Further details regarding the individual steps (cont.)

Number of boilers	2	3	4
Correction factor (set value)	Flue length a (m)		
4	–	$> 19 \leq 25$	$> 10 \leq 13$
5	–	–	$> 13 \leq 18$
6	–	–	$> 18 \leq 21$

Rated heating output 35 kW

Number of boilers	2	3	4
Correction factor (set value)	Flue length a (m)		
0			
1	≤ 10		
2	$> 10 \leq 25$	≤ 8	
3	–	$> 8 \leq 15$	≤ 7
4	–	$> 15 \leq 21$	$> 7 \leq 10$
5	–	$> 21 \leq 25$	$> 10 \leq 13$
6	–	–	$> 13 \leq 16$

Note

The correction factor changes the boiler modulation range.

Further details regarding the individual steps (cont.)

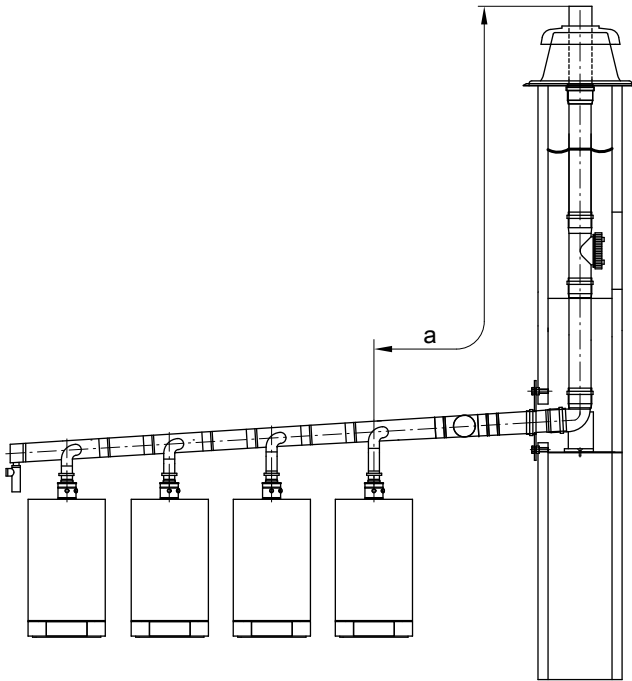

Checking the CO₂ content

The Vitodens 100-W is factory-set for natural gas. During commissioning or maintenance, the CO₂ and CO have to be measured at the boiler flue adaptor test port to check the flue integrity. Subject to the Wobbe index, the CO₂ content fluctuates between 7.4 % and 10.5 %. CO of up to 500 ppm during start-up is acceptable.

We recommend measuring O₂ as the value is unmistakable regarding lambda (air/gas). The O₂ content fluctuates between 7.5 % and 3.2 %. The CO/CO₂ ratio has to be less than 0.004.

If the actual CO₂ or O₂ and CO values deviate from the stated range, check the balanced flue system for leaks. If flue installation is OK, change the gas valve.

Note

Operate the appliance with uncontaminated combustion air to prevent operating faults and damage.

Further details regarding the individual steps (cont.)

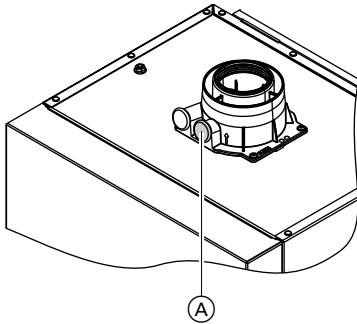

1. Connect a flue gas analyser at flue gas port (A) on the boiler flue connection.
2. Start the boiler and check for leaks.



Danger

Escaping gas leads to a risk of explosion.

Check all gas equipment for tightness.

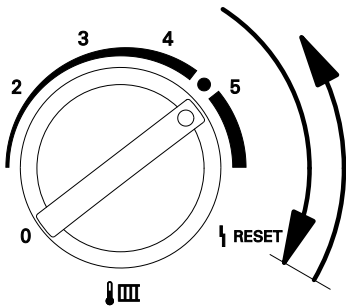

3. Turn rotary selector "🔥 III" for less than 2 s fully clockwise and then back into the r.h. section of the control range.

The display shows "SERV", "🔥" and the boiler water temperature.

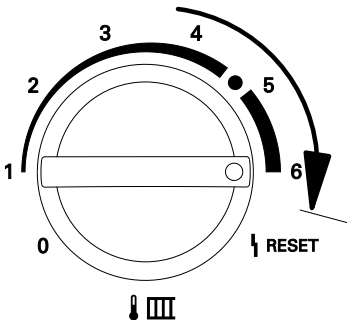

4. Set the upper heating output: Turn rotary selector "🔥 III" into the r.h. section of the control range until the display shows 5 bars for the upper heating output.
5. Check the CO₂ content for the upper heating output. The CO₂ content must be between 7.0 and 10.5 %.

Further details regarding the individual steps (cont.)

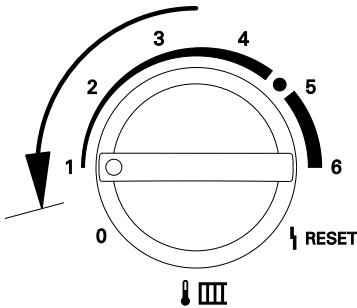

6. Set the lower heating output:
Turn rotary selector "🌡️📊" into the l.h. section of the control range until the display shows 1 bar for the lower heating output.
7. Check the CO₂ content for the lower heating output.
The CO₂ content must be between 0.3 and 0.9 % below the value of the upper heating output.
8.
 - If the CO₂ content is within the given range, continue with point 10.
 - If the CO₂ content lies **outside** the given range, check the flue gas/ventilation air system for tightness; remedy any leaks.
Replace gas train if required.
9. Re-check the CO₂ content for the upper and lower heating output.
10. Shut down the boiler, remove the flue gas analyser and close flue gas test port (A).
11. Turn both rotary selectors "🌡️🔧" and "🌡️📊" to their respective original positions.

Further details regarding the individual steps (cont.)

Burner removal

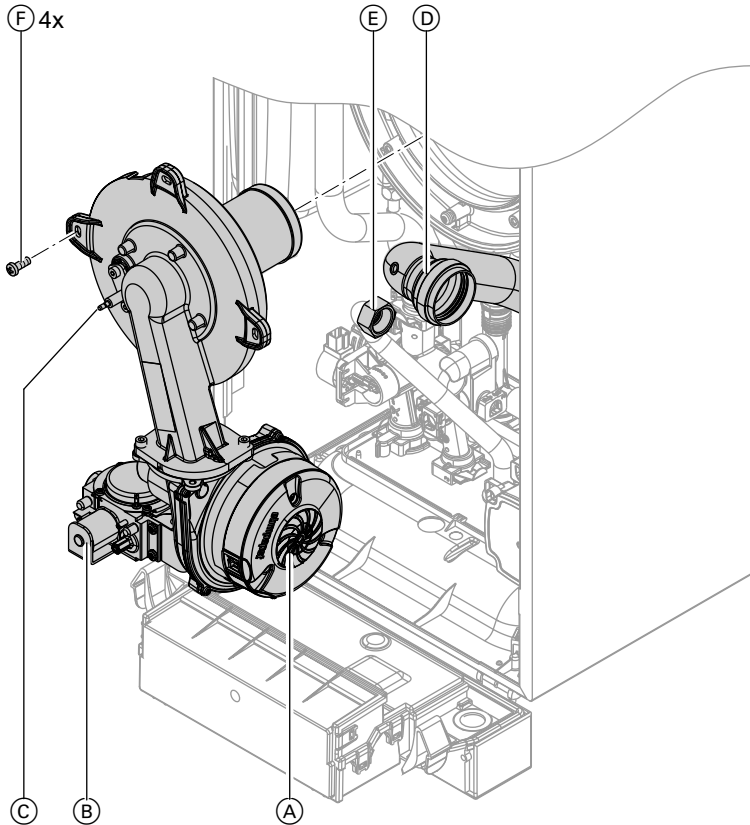

1. Switch off the power supply.
2. Shut off the gas supply.
3. Pull the power cables from fan motor (A), gas train (B) and electrodes (C).
4. Pull venturi extension (D) from the fan.
5. Undo gas supply pipe fitting (E).
6. Undo 4 screws (F) and remove the burner.



Please note
Prevent damage.
Never rest the burner on the burner gauze assembly.

Further details regarding the individual steps (cont.)

Checking the burner gasket and burner gauze assembly

Check burner gasket (A) for damage and replace if required.

Replace the burner gauze assembly if it is damaged.

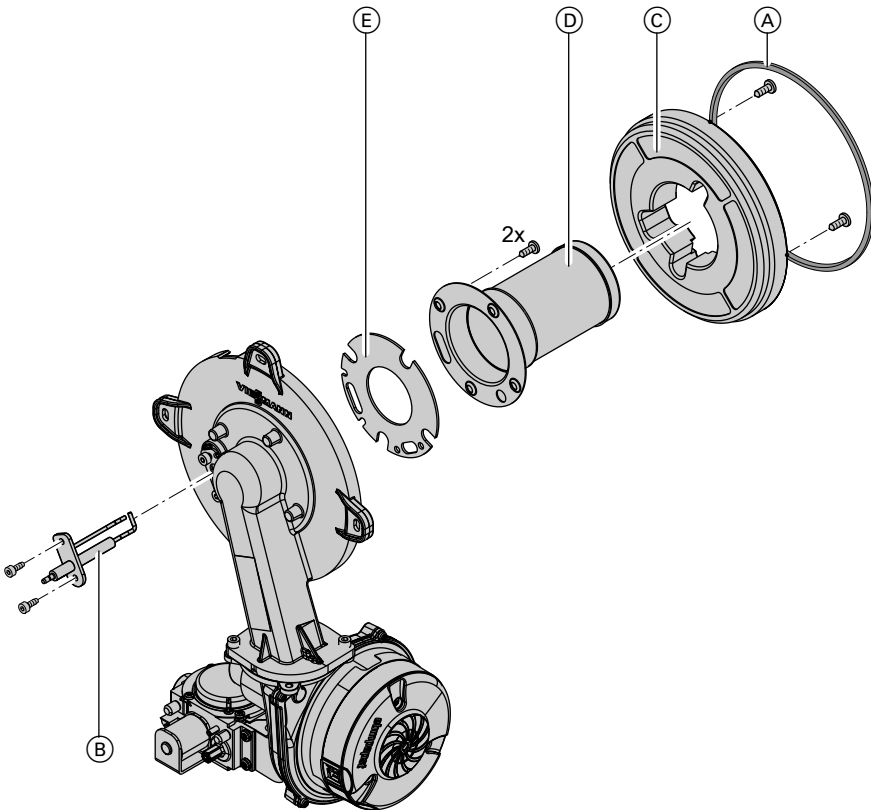

1. Remove electrode (B).
2. Undo the 2 Torx screws and remove thermal insulation ring (C).
3. Undo the 2 Torx screws and remove burner gauze assembly (D) with gasket (E).

4. Insert and secure new burner gauze assembly (D) with new gasket (E).



Please note

Tighten screws just enough to ensure the components do not suffer damage and will function correctly.

Further details regarding the individual steps (cont.)

5. Mount thermal insulation ring (C).



Please note

Tighten screws just enough to ensure the components do not suffer damage and will function correctly.

6. Fit electrode (B).



Please note

Tighten screws just enough to ensure the components do not suffer damage and will function correctly.

Checking and adjusting the electrode

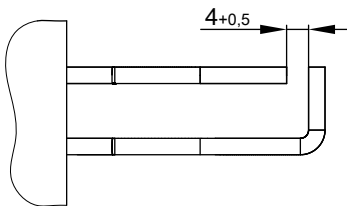
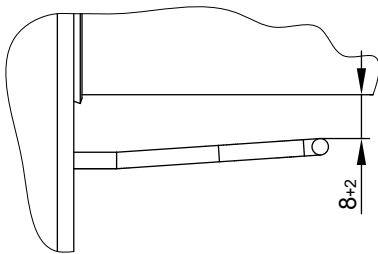

1. Check the electrode for wear and contamination.
2. Clean the electrode with a small brush (not with a wire brush) or emery paper.
3. Check the electrode gaps. If the gaps are not as specified or the electrode is damaged, replace electrode and gasket and realign the electrode. Tighten the electrode fixing screws.



Please note

Tighten screws just enough to ensure the components do not suffer damage and will function correctly.

Cleaning the heat exchanger



Please note

Do not damage the surfaces of the heat exchanger that come into contact with hot gas. This can lead to corrosion damage.

Never use brushes to clean the heat exchanger.

Brushing can cause deposits to become lodged in the gaps between the coils.

Note

Discolouration on the heat exchanger surface is a normal sign of use. It has no bearing on the function and service life of the heat exchanger.

The use of chemical cleaning agents is not required.

Further details regarding the individual steps (cont.)

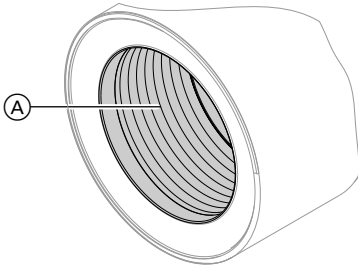

1. Use a vacuum cleaner to remove combustion residues from heating surface (A) of the heat exchanger.
2. Flush heating surface (A) with water.
3. Check condensate drain and clean siphon. See the following chapter.
4. Flush the heating surface again with water (the siphon is also filled with water in the process).

Checking the condensate drain and cleaning the trap

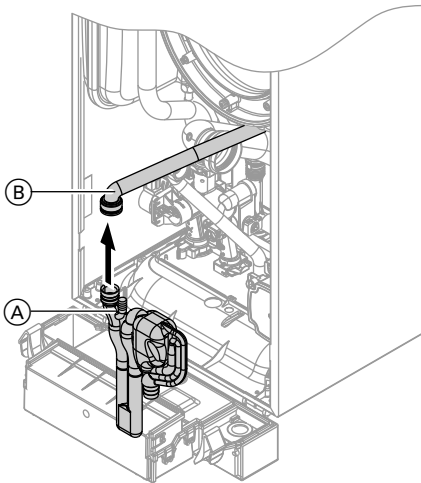

1. Pull trap (A) upwards out of the drain connection.
2. Pull supply hose (B) off trap (A).
3. Clean trap (A).
4. Reconnect supply hose (B).
5. Refit trap (A) to the drain connection.
6. Fill trap (A) with water. For this, pour approx. 0.3 l of water into the combustion chamber.
7. Check that condensate can drain freely and that the connections are tight.

Further details regarding the individual steps (cont.)

Installing the burner

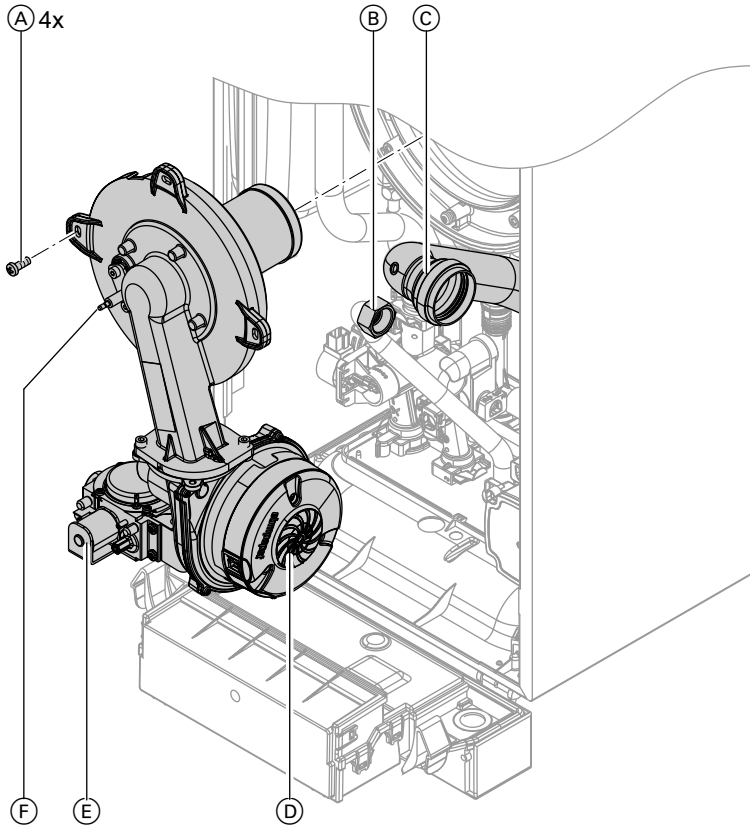

1. Fit burner and tighten 4 screws (A) diagonally.



Please note

Tighten screws just enough to ensure the components do not suffer damage and will function correctly.

3. Plug venturi extension (C) onto the fan.

4. Fit electrical cables to fan motor (D), gas train (E) and ignition unit (F).

5. Reopen gas supply and switch on power supply.

2. Insert new gasket and tighten the fitting on gas supply pipe (B).



Further details regarding the individual steps (cont.)

6. Check gas connections for tightness.



Danger

Escaping gas leads to a risk of explosion.
Check the fitting for gas tightness.



Please note

The use of leak detection spray can result in faulty operation.

Leak detection spray must not come into contact with electrical contacts or seal the diaphragm opening on the gas valve.

Checking the diaphragm expansion vessel and system pressure

Note

The expansion vessel can lose some of its charge pressure after some time in use. When the boiler heats up, the pressure gauge will indicate a higher pressure of 2 or 3 bar (0.2 or 0.3 MPa). The safety valve can respond and discharge excess pressure.

For this reason, check the expansion vessel pre-charge pressure annually.

Check whether the installed expansion vessel is adequate for the system water volume (GB only).

Carry out this test on a cold system.

1. Drain the system until the pressure gauge shows "0".
Alternatively, close the cap valve on the expansion vessel and reduce the pressure until the pressure gauge indicates "0".

2. If the pre-charge pressure of the expansion vessel is lower than the static system pressure, top up with nitrogen until the pre-charge pressure is 0.1 to 0.2 bar (10 to 20 kPa) higher than the static system pressure.
3. Top up with water until the charge pressure of the cooled system is at least 1.0 bar (0.1 MPa), and is 0.1 to 0.2 bar (10 to 20 kPa) higher than the pre-charge pressure of the expansion vessel.
Permiss. operating pressure: 3 bar (0.3 MPa)

Checking the connections on the heating water and the DHW side

Check all connections and lines on the heating water and DHW side (including inside the appliance) for tightness and possible damage.

Further details regarding the individual steps (cont.)

Checking all gas equipment for tightness at operating pressure



Danger

Escaping gas leads to a risk of explosion.
Check all gas equipment for tightness.



Please note

The use of leak detection spray can result in faulty operation. Leak detection spray must not come into contact with electrical contacts or seal the diaphragm opening on the gas valve.

Fitting the front panel

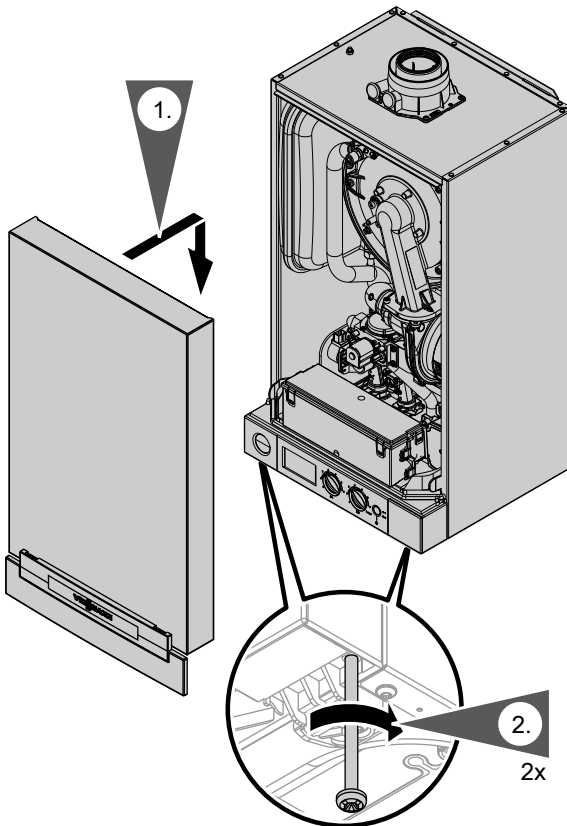

1. Hook the front panel into place.

2. Tighten screws on the underside.

Further details regarding the individual steps (cont.)

Instructing the system user

The system installer should hand the operating instructions to the system user and instruct the user in operating the system.

Function sequence and possible faults

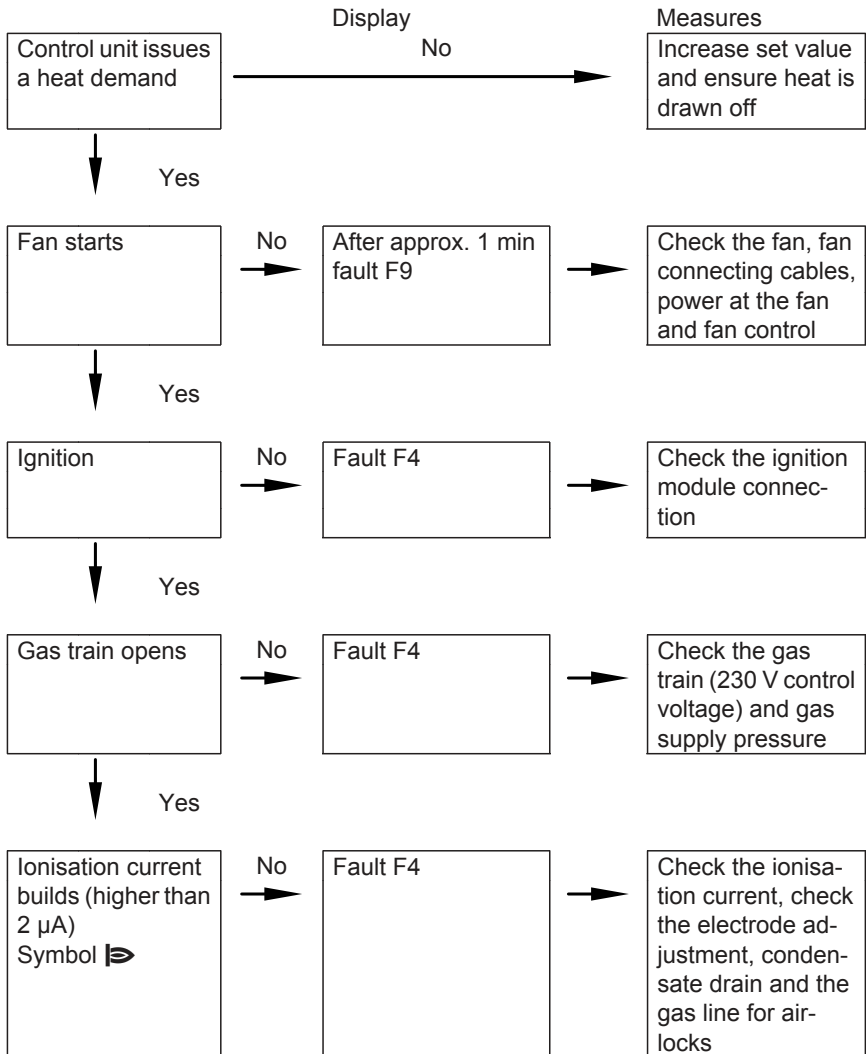

Function sequence and possible faults (cont.)

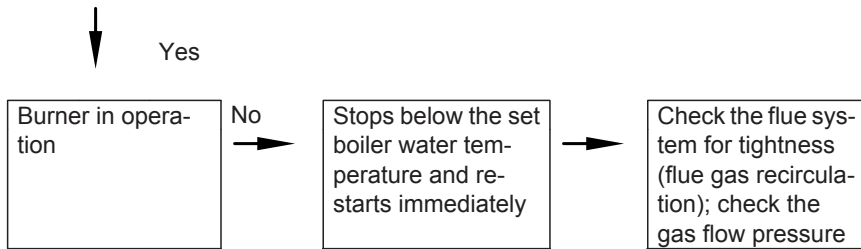

Fault display

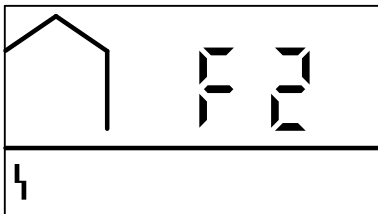

Faults are indicated by a flashing fault code with fault symbol "L" on the display.

For an explanation of the fault codes, see the following table.

Displayed fault code	System characteristics	Cause	Measures
10	Constant temperature mode	Short circuit, outside temperature sensor	Check the outside temperature sensor and lead (see page 66).
18	Constant temperature mode	Lead break, outside temperature sensor	Check the outside temperature sensor and lead (see page 66).
30	Burner blocked	Short circuit, boiler water temperature sensor	Check boiler water temperature sensor (see page 68).
38	Burner blocked	Lead break, boiler water temperature sensor	Check boiler water temperature sensor (see page 68).
50	No DHW heating	Short circuit, cylinder temperature sensor	Check sensor (see page 69).

Fault display (cont.)

Displayed fault code	System characteristics	Cause	Measures
51	No DHW heating	Short circuit, outlet temperature sensor	Check sensor (see page 71).
52	Burner blocked	Short circuit, flow sensor	Check connections and lead; replace sensor if required.
58	No DHW heating	Lead break, cylinder temperature sensor	Check sensor (see page 69).
59	No DHW heating	Lead break, outlet temperature sensor	Check sensor (see page 71).
5A	Burner blocked	Lead break, flow sensor	Check connections and lead; replace sensor if required.
A9	Control mode without OpenTherm device	Communication error, OpenTherm device	Check connections and lead; replace OpenTherm device if required.
b0	Burner blocked	Short circuit, flue gas temperature sensor	Check sensor (see page 72).
b8	Burner blocked	Lead break, flue gas temperature sensor	Check sensor (see page 72).
E3	Burner in a fault state	Fault in safety chain	Check the temperature limiter and connecting cables (see page 70). Check the control unit, and replace if required.
E5	Burner blocked	Internal fault	Check the ionisation electrode and connecting cables. Press "Reset" (see page 65).
F0	Burner blocked	Internal fault	Replace control unit.
F1	Burner in a fault state	Max. flue gas temperature exceeded	Check heating system fill level. Check circulation pump. Vent the system. Press "Reset" (see page 65).



Fault display (cont.)

Displayed fault code	System characteristics	Cause	Measures
F2	Burner in a fault state	Temperature limiter has responded	Check heating system fill level. Check circulation pump. Vent the system. Check the temperature limiter and connecting cables (see page 70). Press "Reset" (see page 65).
F3	Burner in a fault state	Flame signal is already present at burner start	Check ionisation electrode and connecting cable. Press "Reset" (see page 65).
F4	Burner in a fault state	No flame signal detected	Check the ignition/ionisation electrode and connecting cables, check the gas pressure, check the gas train, ignition, ignition module and condensate drain. Press "Reset" (see page 65).
F8	Burner in a fault state	Fuel valve closes too late	Check gas train. Check both control paths. Press "Reset" (see page 65).
F9	Burner in a fault state	Fan speed too low during burner start	Check fan, fan connecting cables and power supply; check fan control. Press "Reset" (see page 65).
FA	Burner in a fault state	Fan idle state not reached	Check fan, fan connecting cables and fan control. Press "Reset" (see page 65).
FC	Burner blocked	Electrical fan control (control unit) faulty	Check fan connecting cable; replace if required, or replace control unit.

Fault display (cont.)

Displayed fault code	System characteristics	Cause	Measures
Fd	Burner blocked	Burner control unit fault	<p>Check ignition electrodes and connecting cables. Check whether a strong interference (EMC) field exists near the appliance.</p> <p>Press "Reset" (see page 65). Replace control unit if fault persists.</p>
FF	Burner blocked	Burner control unit fault	<p>Check ignition electrodes and connecting cables. Check whether a strong interference (EMC) field exists near the appliance.</p> <p>Press "Reset" (see page 65). Replace control unit if fault persists.</p>

Initiating a reset

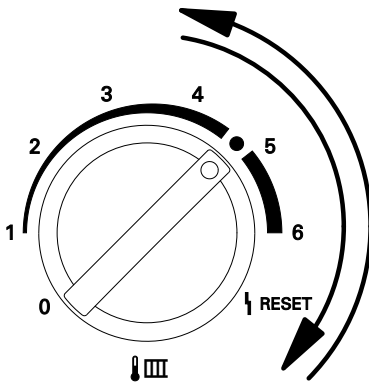

Turn rotary selector "III 🔥" to "I RESET" for less than 2 s, then back into the control range section.

Repairs

Removing the front panel

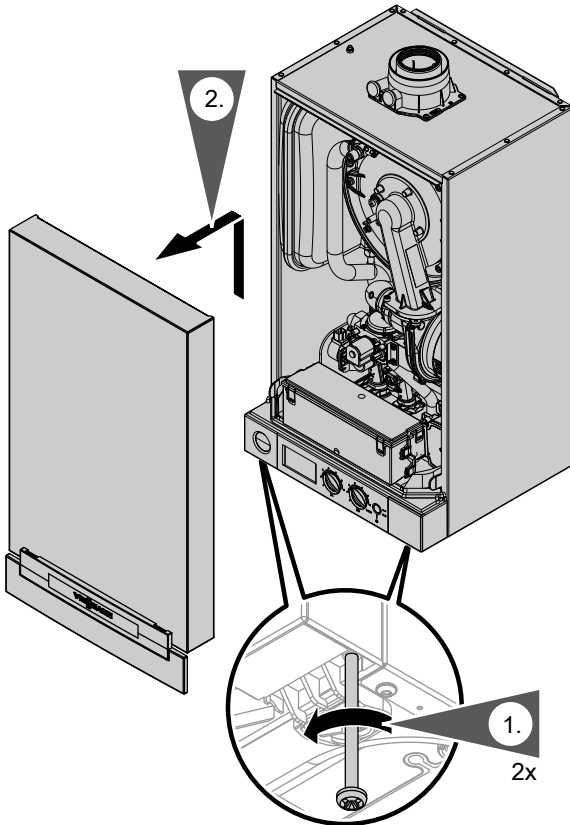

1. Undo screws at the bottom of the boiler; do not remove completely.

2. Remove the front panel.

Outside temperature sensor

1. Open the control unit enclosure. See page 20.

Repairs (cont.)

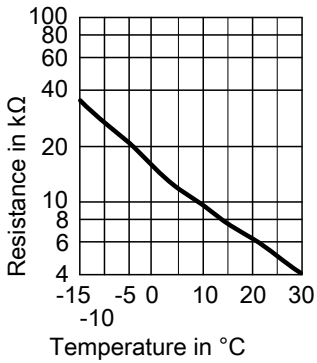
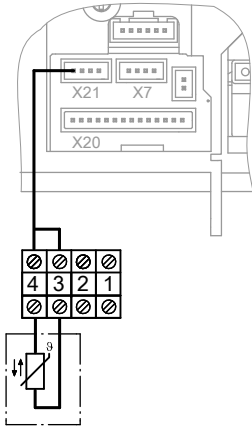

2. Disconnect outside temperature sensor leads.

3. Check the sensor resistance and compare it with the curve.

4. In the event of severe deviation replace the sensor.

Repairs (cont.)

Boiler water temperature sensor

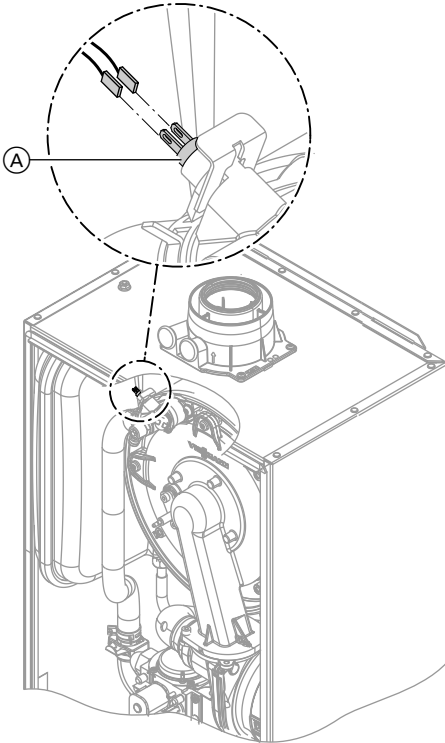

1. Pull the leads from boiler water temperature sensor (A) and check the resistance.

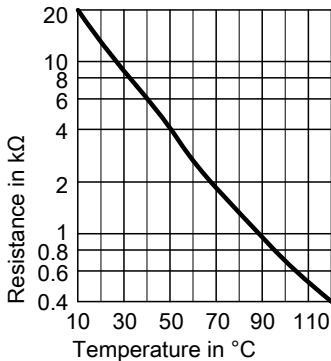

2. Check the sensor resistance and compare it with the curve.
3. In the case of severe deviation, drain the boiler on the heating water side and replace the sensor.



Danger

The boiler water temperature sensor is in direct contact with the heating water (risk of scalding). Drain the boiler before replacing the sensor.

Repairs (cont.)

Checking the cylinder temperature sensor (gas condensing boiler)

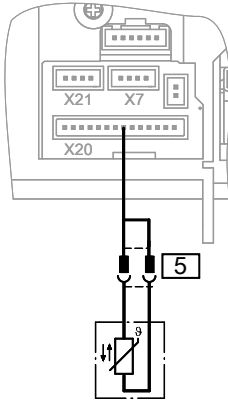

1. Remove plugs **5** from the cable harness and check the resistance.

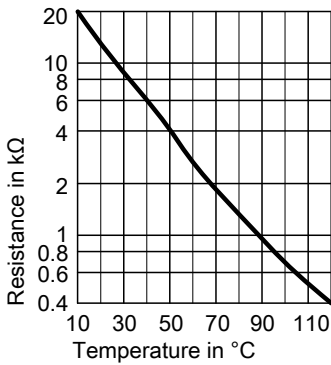

2. Compare the sensor resistance with the curve.
3. In the event of severe deviation replace the sensor.

Repairs (cont.)

Checking the temperature limiter

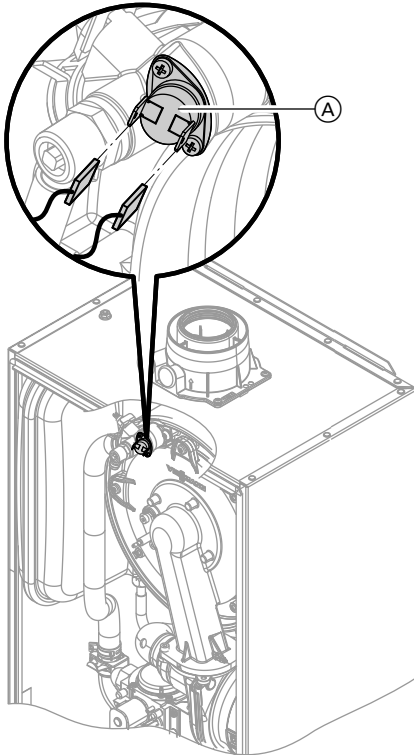

If the burner control unit cannot be reset after a fault shutdown, although the boiler water temperature is below approx. 95 °C, check the temperature limiter.

1. Pull the cables from temperature limiter (A).
2. Check the continuity of the temperature limiter with a multimeter.
3. Remove the faulty temperature limiter.
4. Install a new temperature limiter.
5. Reset by pressing "Reset" on the control unit to (see page 65).

Repairs (cont.)

Checking the outlet temperature sensor (gas condensing combi boiler)

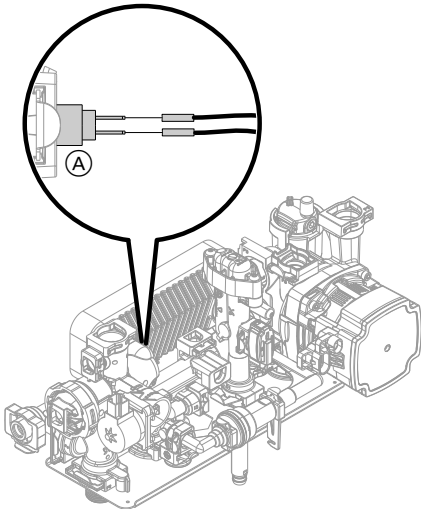

1. Pull leads from outlet temperature sensor (A).
2. Check the sensor resistance and compare it with the curve.

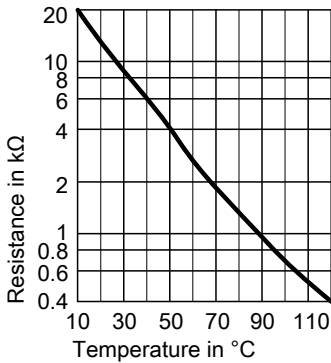

3. In the event of severe deviation replace the sensor.

Note

Water can leak when replacing the outlet temperature sensor. Shut off the cold water supply. Drain the DHW line and the plate heat exchanger (on the DHW side).

Repairs (cont.)

Check flue gas temperature sensor

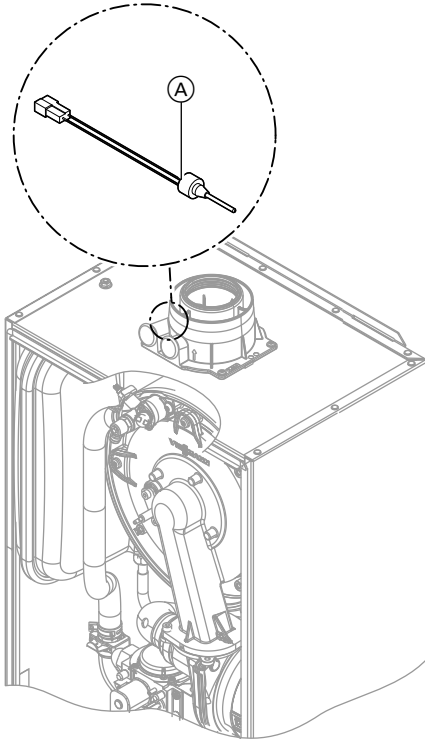

1. Pull leads from flue gas temperature sensor (A).
2. Check the sensor resistance and compare it with the curve.

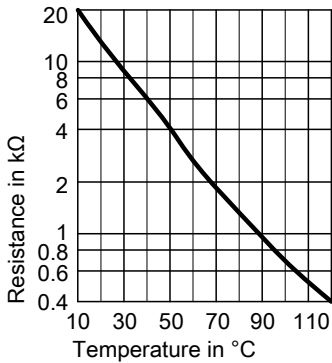

3. In the event of severe deviation replace the sensor.

Repairs (cont.)

Replacing the flow limiter (gas condensing combi boiler)

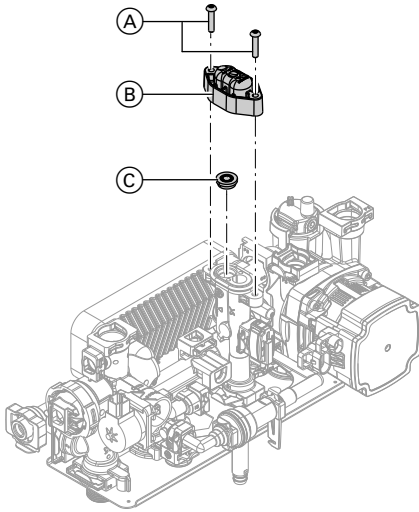

1. Drain the boiler on the DHW side.
2. Pivot the control unit downwards.
3. Undo screws (A).
4. Remove cap (B).
5. Remove faulty flow limiter (C).
6. Select new flow limiter (C) according to the boiler serial no. (see type plate) and the following table.
7. Insert new flow limiter (C).
8. Mount new cap (B) provided.

Serial no. (type plate)	Flow rate l/min	Colour
7543422	10	Black
7543424	12	Red
7543426	14	Brown

Repairs (cont.)

Checking or replacing the plate heat exchanger (gas condensing combi boiler)

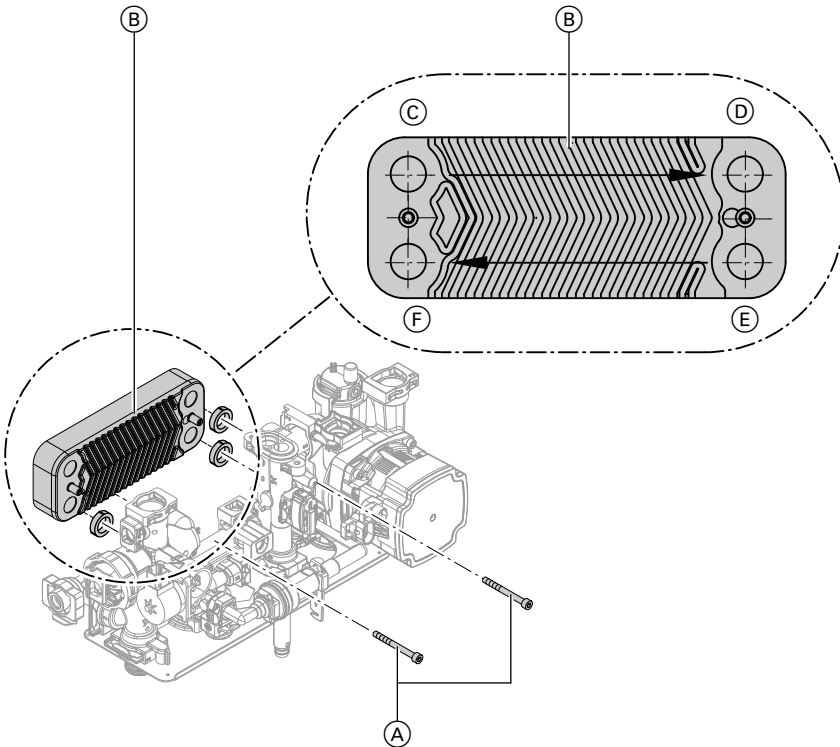

- (C) Heating water flow
- (D) Heating water return

- (E) Cold water
- (F) DHW

1. Shut off and drain the boiler on the heating water and the DHW side.
2. Pivot the control unit downwards.
3. Undo 2 screws (A) on plate heat exchanger (B) and remove plate heat exchanger with gaskets.

Note

During and after removal, small amounts of water may trickle from the plate heat exchanger.

Repairs (cont.)

4. Check the connections on the DHW side for scaling; clean or replace the plate heat exchanger if required.
5. Check the connections on the heating water side for contamination; clean or replace the plate heat exchanger if required.
6. Install in reverse order using new gaskets.

Note

During installation, ensure the fixing holes are aligned and the gaskets are seated correctly. Mount the plate heat exchanger with the correct orientation.

Checking the fuse

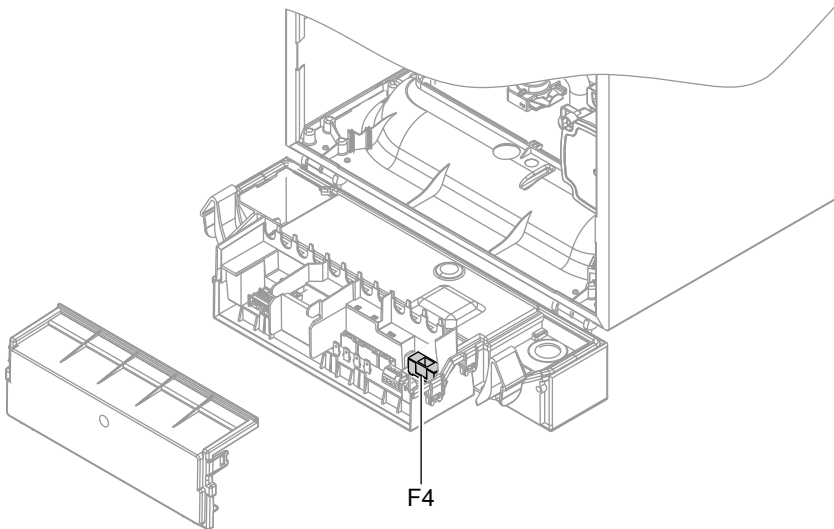

1. Switch off the power supply.
2. Open control unit enclosure (see page 20).
3. Check fuse F4.

Converting from LPG to natural gas

Removing the gas restrictor

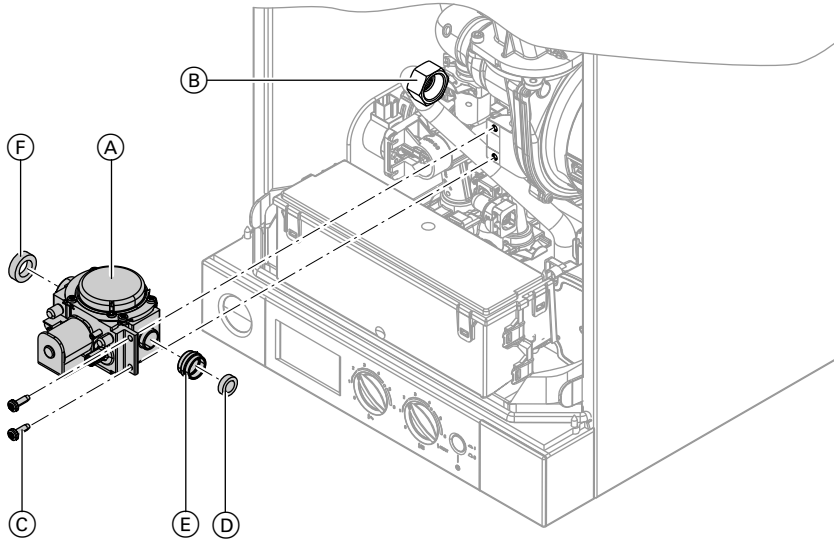

1. Pull cable from gas train (A).
2. Undo union nut (B).
3. Undo 2 screws (C) and remove gas train (A).
4. Remove gas restrictor (D) from gas train (A).
5. Mount gas train (A) with new gaskets (E) and (F).
6. Remove or void gas type sticker on the top of the boiler (next to the type plate).
7. Start the boiler and check for leaks.



Danger

Escaping gas leads to a risk of explosion. Check all gas equipment for tightness.



Please note

Tighten screws just enough to ensure the components do not suffer damage and will function correctly.

Converting from LPG to natural gas (cont.)

Changing the gas type at the control unit

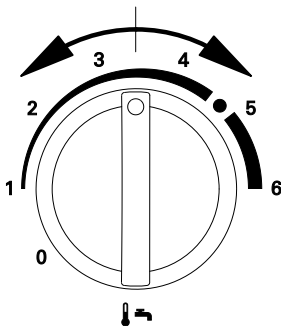
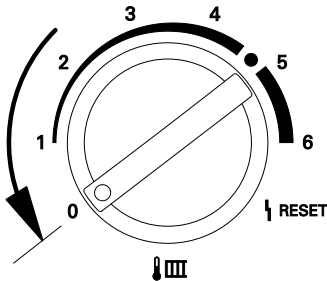
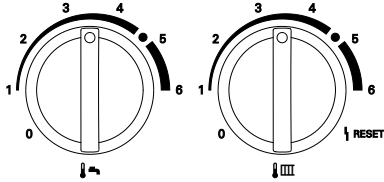

1. Switch ON the ON/OFF switch.
2. Turn both rotary selectors "🔥🔧" and "🔥🔧" simultaneously to their central positions.
The display shows "SERV".
3. Turn rotary selector "🔥🔧" within 2 s fully anticlockwise.
The set value and "🔥" flash on the display.
4. Change the control unit setting to natural gas or LPG by turning rotary selector "🔥🔧".
The display shows:
 - "0" for operation with natural gas or
 - "1" for operation with LPG
5. The set operating mode is programmed when the value stops flashing, and the control unit returns to standard mode.

Checking the CO₂ content

See page 50.

Functions and operating conditions in weather-compensated mode

In weather-compensated mode, the boiler water temperature is regulated according to the outside temperature.

Heating curve for weather-compensated control

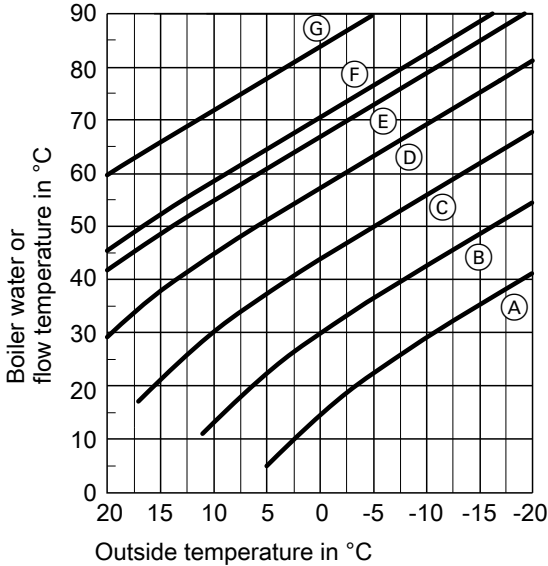

Setting of rotary selector "🌡️📊"

- (A) = 1
- (B) = 2
- (C) = 3
- (D) = 4
- (E) = delivered condition
- (F) = 5
- (G) = 6

Frost protection function

The frost protection function requires an outside temperature sensor to be connected. The frost protection function becomes active at outside temperatures of $< 5\text{ °C}$. The burner starts and the boiler water temperature is held at 20 °C .

Connection and wiring diagram

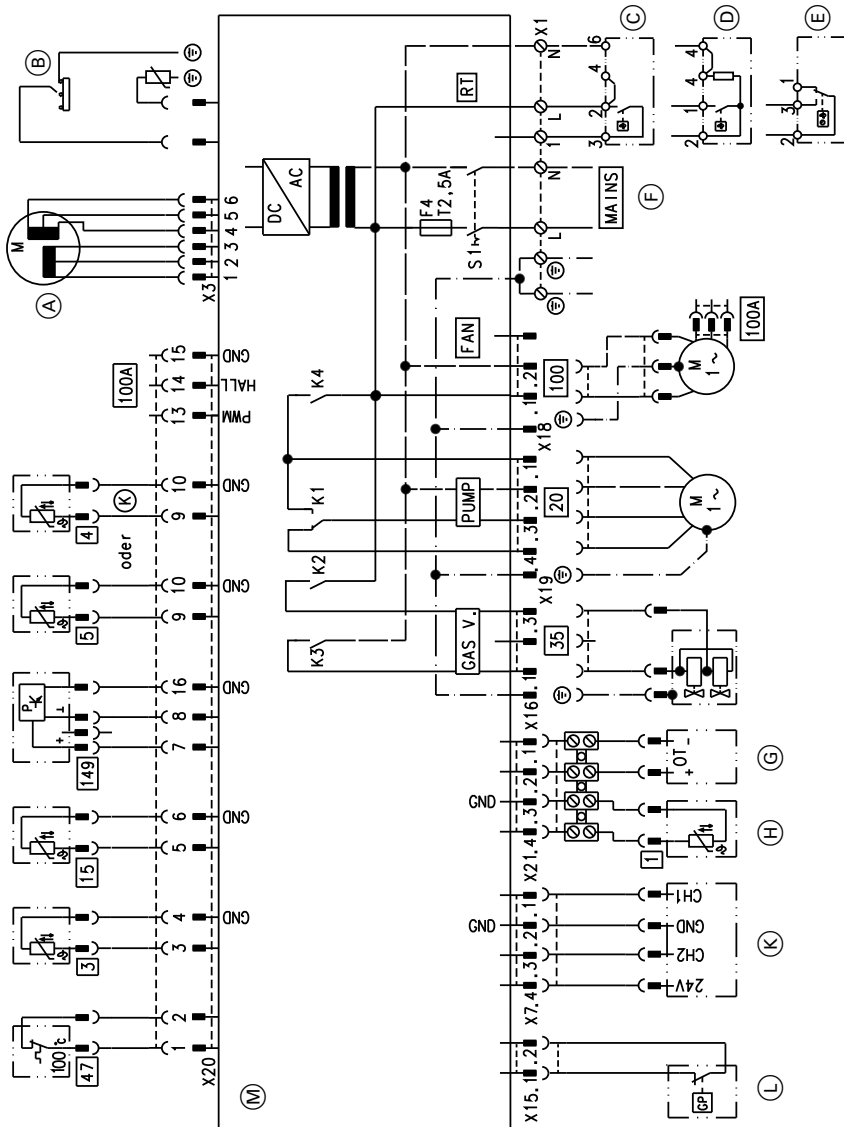

- (A) Diverter valve stepper motor
- (B) Ignition/ionisation

- (C) Vitotrol 100 type UTA or on-site room temperature controller (switched 230 V input)

Connection and wiring diagram (cont.)

- Ⓓ Vitotrol 100, type RT or on-site room temperature controller (switched 230 V input)
- Ⓔ Vitotrol 100, type UTDB or on-site room temperature controller (switched 230 V input)
- Ⓕ Power supply 230 V/50 Hz
- Ⓖ Remote control (OpenTherm device)
- Ⓗ Outside temperature sensor (accessories)
- Ⓚ Time switch (accessories)
- Ⓛ Gas pressure switch (accessories)
- Ⓜ PCB inside the control unit
- X ... Electrical interface
- 3 Boiler water temperature sensor
- 4 Outlet temperature sensor (gas condensing combi boiler)
- 5 Gas condensing boiler:
 - For Viessmann DHW cylinders: Cylinder temperature sensor
 - In the case of alternative DHW cylinders compliant with the G3 Directive:
 - Cylinder demand junction box (for connection of a 230 V cylinder temperature controller and a 2-way shut-off valve)
- 15 Flue gas temperature sensor
- 20 Circulation pump 230 V~
- 35 Gas solenoid valve
- 47 Temperature limiter
- 100 Fan motor 230 V~
- 100A Fan control
- 149 Flow sensor

Ordering parts

The following information is required:

- Serial no. (see type plate (A))
- Assembly (from this parts list)
- Position number of the individual part within the assembly (from this parts list)

Standard parts are available from your local supplier.

Overview of assemblies

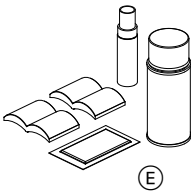
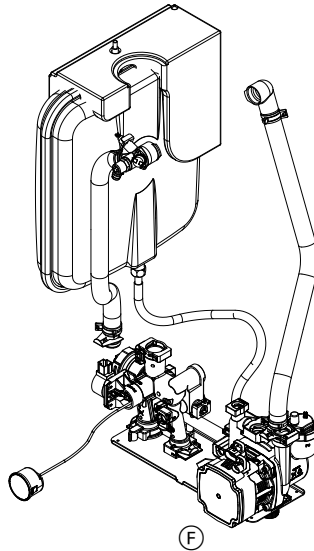
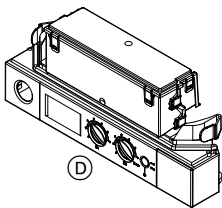
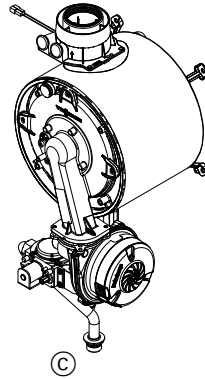
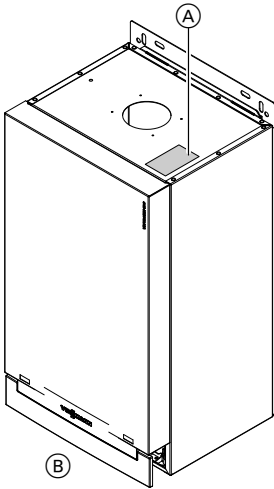

- (A) Type plate
- (B) Sheet metal parts assembly
- (C) Heat cell assembly

- (D) Control unit assembly
- (E) Miscellaneous
- (F) Hydraulic assembly

Sheet metal parts assembly

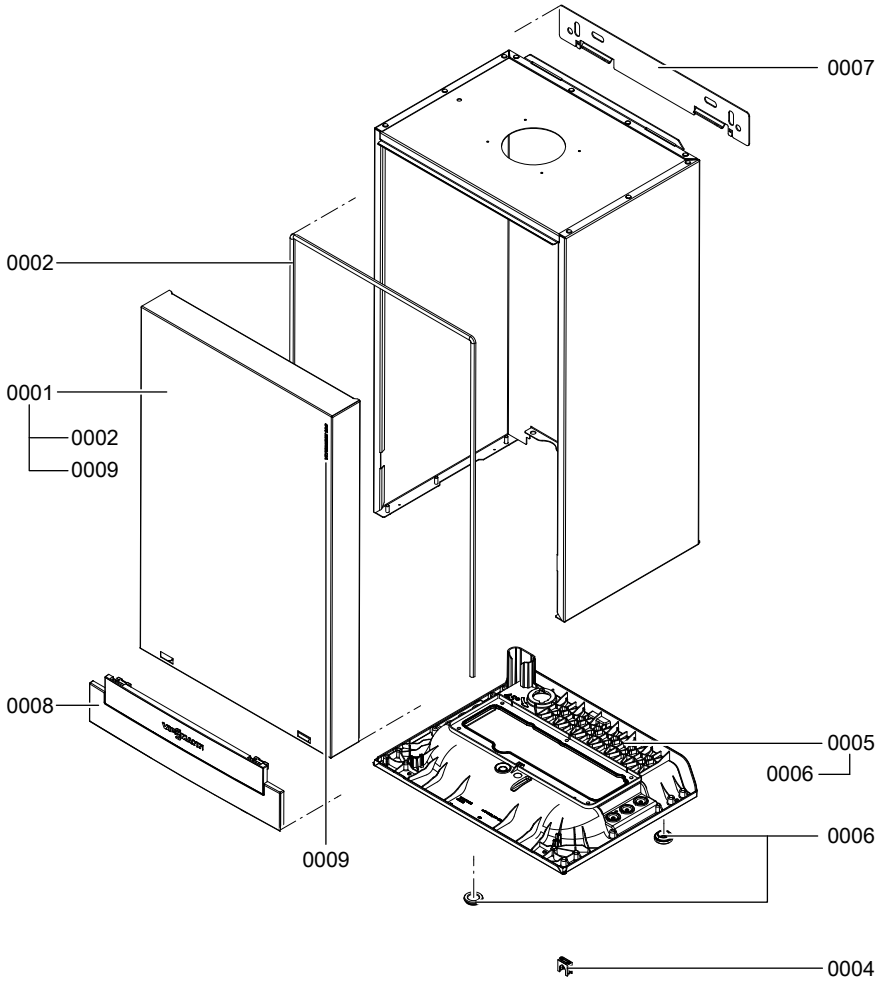

Sheet metal parts assembly (cont.)

Pos.	Part
0001	Front panel
0002	Profiled seal
0004	Strain relief upper part
0005	Air box floor
0006	Diaphragm grommets (set)
0007	Wall mounting bracket
0008	Control flap
0009	Vitodens 100 logo

Heat cell assembly

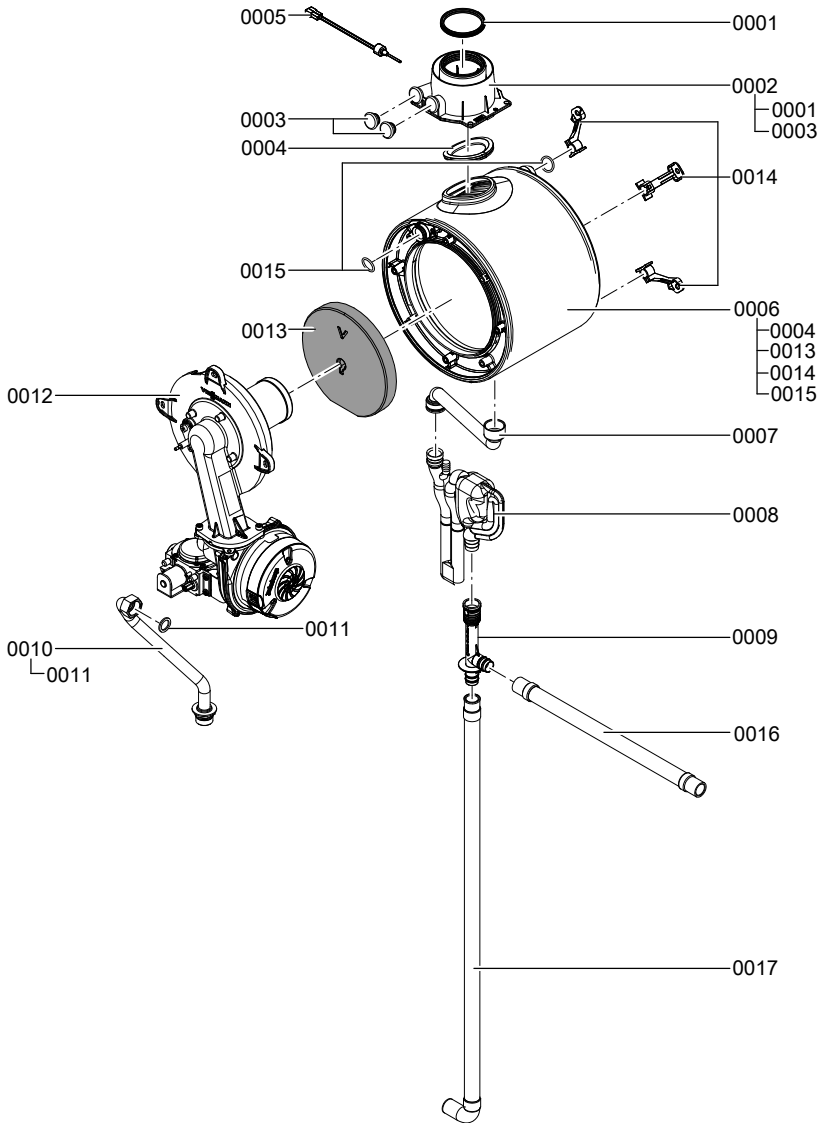

Heat cell assembly (cont.)

Pos.	Part
0001	Gasket DN 60
0002	Boiler flue connection
0003	Boiler flue connection plug
0004	Flue gasket
0005	Flue gas temperature sensor
0006	Heat exchanger
0007	Condensate hose
0008	Splash trap
0009	Tee union
0010	Gas connection
0011	Gasket A 17 x 24 x 2 (5 pce)
0012	Burner (see burner assembly)
0013	Thermal insulation block
0014	Heat exchanger mounting (set)
0015	O-ring 20.63 x 2.62 (5 pce)
0016	Condensate hose 400
0017	Corrugated hose 19 x 800 with ferrule/bend

Burner assembly

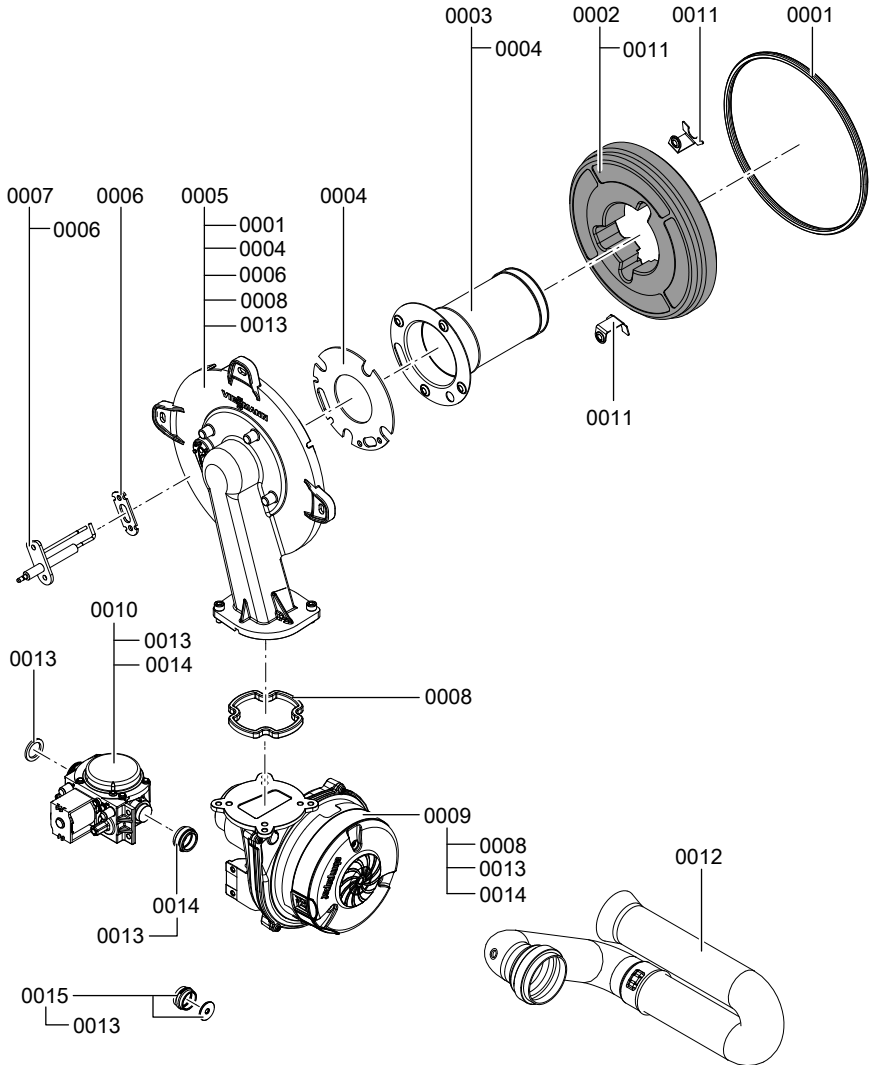

Burner assembly (cont.)

Pos.	Part
0001	Burner gasket \varnothing 187 (wearing part)
0002	Thermal insulation ring
0003	Cylinder burner gauze assembly
0004	Burner gauze assembly gasket
0005	Burner door
0006	Gasket, ionisation electrode (5 pce)
0007	Ignition/ionisation electrode
0008	Gasket, burner door flange (wearing part)
0009	Radial fan NRG 118
0010	Gas valve GB-ND 055 E01
0011	Mounting plate, thermal insulation ring (2 pce)
0012	Venturi extension
0013	Gasket A 17 x 24 x 2 (5 pce)
0014	Gasket set
0015	Conversion kit G31

Hydraulic assembly

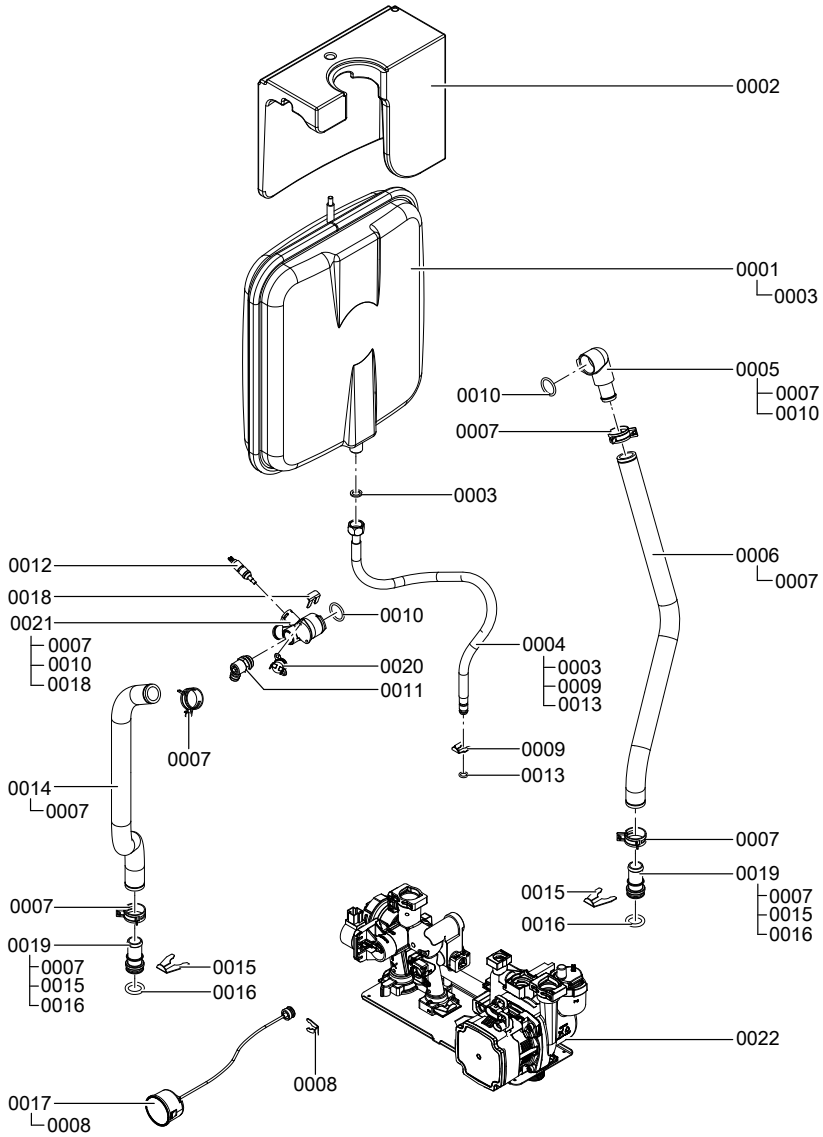

Hydraulic assembly (cont.)

Pos.	Part
0001	Diaphragm expansion vessel CRI 8
0002	Cushion
0003	Gasket A 10 x 15 x 1.5 (5 pce)
0004	DEV connection line G 3/8
0005	Connection elbow HR brass
0006	Profile hose HR
0007	Spring clip DN 25 (5 pce)
0008	Clip \varnothing 10 (5 pce)
0009	Clip \varnothing 8 narrow (5 pce)
0010	O-ring 20.63 x 2.62 (5 pce)
0011	Air vent valve G 3/8
0012	Temperature sensor
0013	Circular seal washer 8 x 2 (5 pce)
0014	Profile hose HF
0015	Clip \varnothing 18 (5 pce)
0016	O-ring 17 x 4 (5 pce)
0017	Pressure gauge
0018	Clip \varnothing 8 (5 pce)
0019	Hose connector adaptor
0020	Thermal circuit breaker
0021	Connection elbow HF
0022	Hydraulics (see hydraulic assembly, system or combi boiler)

Hydraulic assembly, system boiler

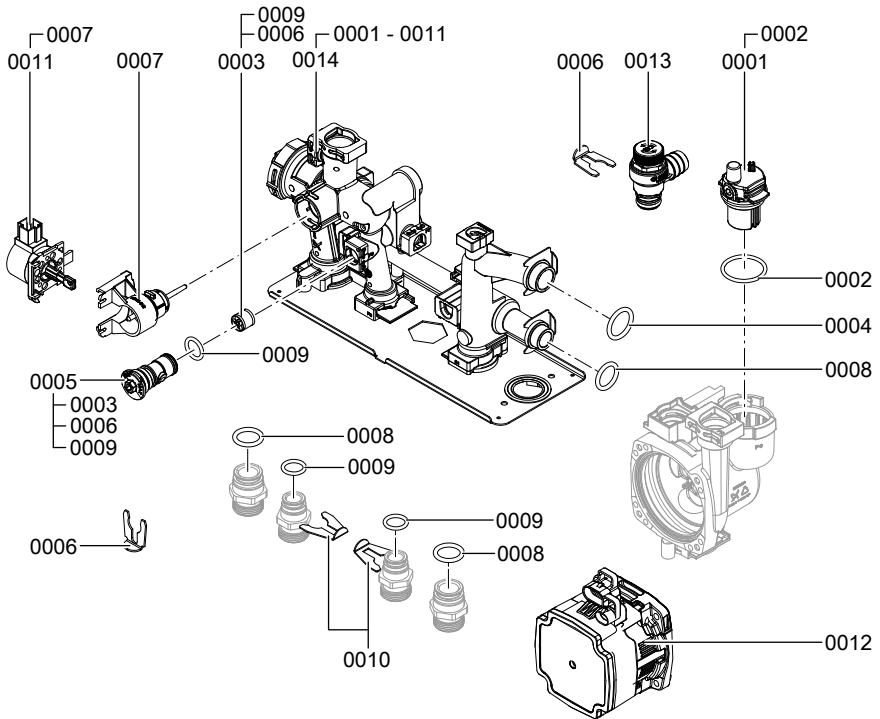

Pos.	Part
0001	Air vent valve
0002	O-ring 34 x 3 (5 pce)
0003	Check valve
0004	O-ring 23.7 x 3.6 (5 pce)
0005	Bypass cartridge
0006	Clip \varnothing 16 (5 pce)
0007	Stepper motor adaptor
0008	O-ring 19.8 x 3.6 (5 pce)
0009	O-ring 16 x 3 (5 pce)
0010	Clip \varnothing 18 (5 pce)
0011	Linear stepper motor
0012	Circulation pump motor UPM3 15-75
0013	Safety valve 3 bar
0014	Hydraulic assembly, system boiler

Hydraulic assembly, combi boiler

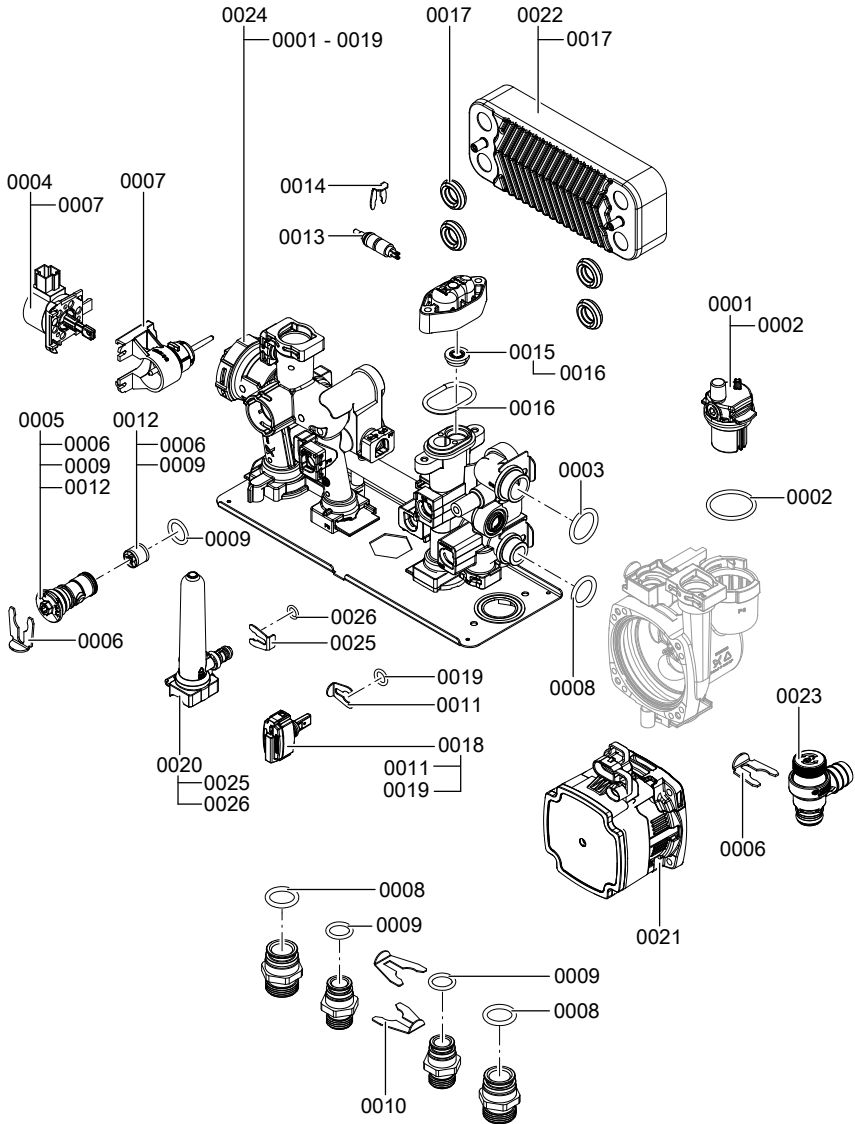

Hydraulic assembly, combi boiler (cont.)

Pos.	Part
0001	Air vent valve
0002	O-ring 34 x 3 (5 pce)
0003	O-ring 23.7 x 3.6 (5 pce)
0004	Linear stepper motor
0005	Bypass cartridge
0006	Clip \varnothing 16 (5 pce)
0007	Stepper motor adaptor
0008	O-ring 19.8 x 3.6 (5 pce)
0009	O-ring 16 x 3 (5 pce)
0010	Clip \varnothing 18 (5 pce)
0011	Clip \varnothing 10 (5 pce)
0012	Check valve
0013	Temperature sensor
0014	Clip \varnothing 8 narrow (5 pce)
0015	Water volume controller
0016	Oval cap seal (5 pce)
0017	Gasket set, plate heat exchanger
0018	Flow sensor
0019	O-ring 9.6 x 2.4 (5 pce)
0020	Expansion vessel
0021	Circulation pump motor UPM3 15-75
0022	Plate heat exchanger
0023	Safety valve 3 bar
0024	Hydraulic assembly, combi boiler
0025	Clip \varnothing 8 (5 pce)
0026	Circular seal washer 8 x 2 (5 pce)

Control unit assembly

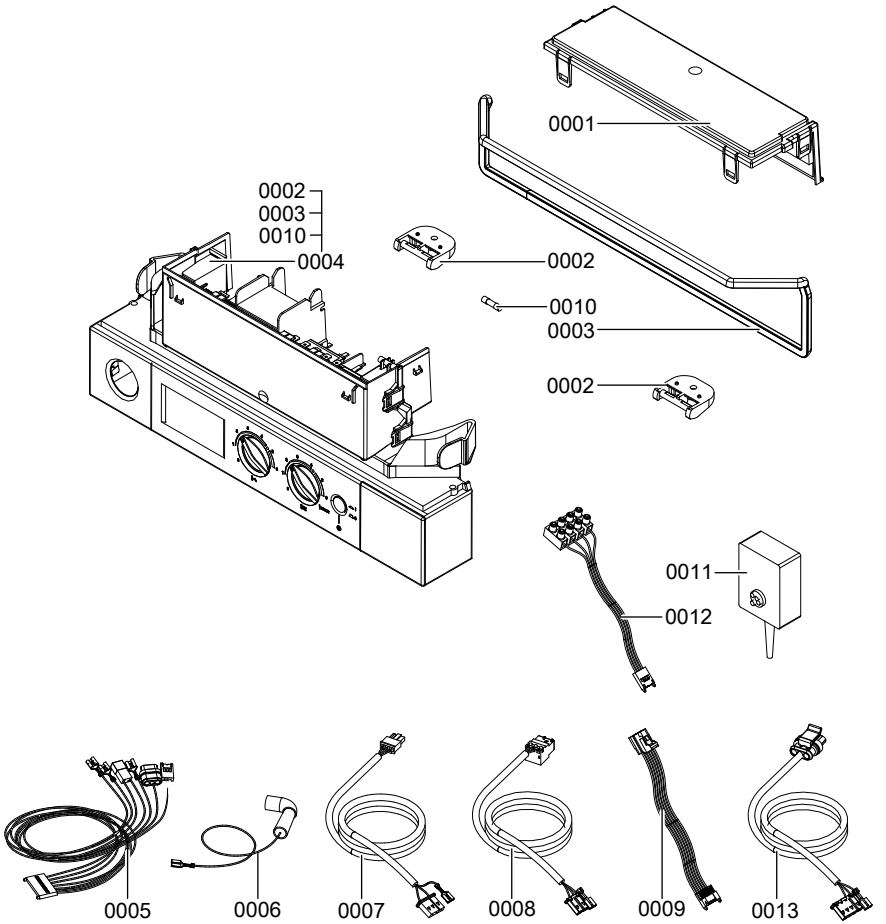

Pos.	Part
0001	Cover, wiring chamber
0002	Clip hinge
0003	Profiled seal
0004	Control unit VBC113-C11.xx
0005	Cable harness X20
0006	Ignition cable with angled plug 5 kΩ
0007	Gas valve connecting cable 35
0008	Fan connecting cable 100
0009	Cable harness, stepper motor AMP-X

Control unit assembly (cont.)

Pos.	Part
0010	Fuse, 2.5 A (slow), 250 V (10 pce)
0011	Outside temperature sensor NTC 5 K
0012	Lead, outside temperature sensor
0013	Connecting cable, heating circuit pump 20

Miscellaneous

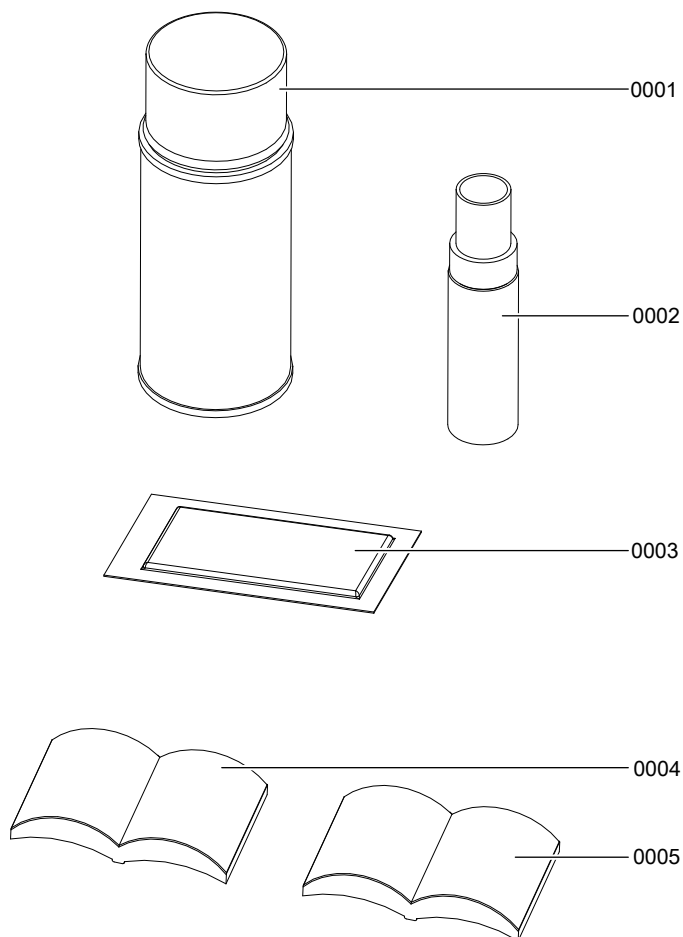

Miscellaneous (cont.)

Pos.	Part
0001	Touch-up spray paint, white, 150 ml
0002	Touch-up paint stick, white
0003	Special grease
0004	Operating instructions
0005	Installation and service instructions

Specification

Rated voltage:	230 V~	Temperature limiter setting:	100 °C (fixed)
Rated frequency:	50 Hz	Backup fuse (power supply):	3 A
Rated current:	2.0 A~		
Safety category:	I		
IP rating:	IP X4 to EN 60529 (only for room sealed operation)		

Permissible ambient temperature

- During operation: 0 to +40 °C
- During storage and transport: -20 to +65 °C

Gas boiler, category II_{2H3P}

Rated heating output range in heating mode					
T_F/T_R 50/30 °C	kW	6.5 – 19	6.5 – 26	8.8 – 30	8.8 – 35
T_F/T_R 80/60 °C	kW	5.9 – 17.3	5.9 – 23.7	8.0 – 27.3	8.0 – 31.9
Rated heating output range for DHW heating (gas condensing combi boiler)	kW	5.9 – 17.3	5.9 – 26.0	8.0 – 30.0	8.0 – 35.0
Rated heat input range	kW	6.1 – 17.8	6.1 – 27.1	8.2 – 31.3	8.2 – 36.5
Connection values *1					
Relative to max. load with:					
- Natural gas E	m ³ /h	1.9	2.6	3.0	3.5
- LPG P	kg/h	1.4	1.9	2.2	2.6
Power consumption (max.)					
- Gas condensing boiler	W	84	92	98	108
- Gas condensing combi boiler	W	—	97	105	119
Weight					
- Gas condensing boiler	kg	35	36	37	37

*1 The connection values are only for reference (e.g. in the gas contract application) or for a supplementary, rough estimate to check the volumetric settings. Due to factory settings, the gas pressure must not be altered from these values. Reference: 15 °C, 1013 mbar.

Specification (cont.)

Rated heating output range in heating mode					
T_F/T_R 50/30 °C	kW	6.5 – 19	6.5 – 26	8.8 – 30	8.8 – 35
T_F/T_R 80/60 °C	kW	5.9 – 17.3	5.9 – 23.7	8.0 – 27.3	8.0 – 31.9
- Gas condensing combi boiler	kg	—	36	38	38
Gas condensing combi boiler (DHW heating)					
Permiss. operating pressure	bar	—	10	10	10
	MPa	—	1	1	1
Nominal water flow rate at ΔT 35 K (to EN 13203)	l/min	—	10.6	12.3	14.3
Set flow rate (max.)	l/min	—	10.0	12.0	14.0
Product ID		C€-0085BT0029			

Final decommissioning and disposal

Viessmann products can be recycled. Components and substance from the system are not part of ordinary household waste.

For decommissioning the system, isolate the system from the power supply and allow components to cool down where appropriate.

All components must be disposed of correctly.

Declaration of conformity

Declaration of Conformity for the Vitodens 100-W

We, Viessmann Werke GmbH & Co KG, D-35107 Allendorf, confirm as sole responsible body that the product **Vitodens 100-W** complies with the following standards:

EN 297	EN 55 014-2
EN 483	EN 60 335-1
EN 625	EN 60 335-2-102
EN 677	EN 61 000-3-2
EN 806	EN 61 000-3-3
EN 12 897	EN 62 233
EN 55 014-1	

In accordance with the following Directives and regulations, this product is designated **CE-0085**:

92/42/EEC	2009/125/EC* ²
2004/108/EC	2010/30/EU* ²
2006/95/EC	811/2013* ²
2009/142/EC	813/2013* ²

This product complies with the requirements of the Efficiency Directive (92/42/EEC) for **condensing boilers**.

Allendorf, 01 March 2015

Viessmann Werke GmbH & Co KG



Authorised signatory Manfred Sommer

*² Valid from September 2015

Keyword index

- A**
Adjusting the pump rate.....37
- B**
Boiler water temperature sensor68
Burner gasket.....54
Burner gauze assembly.....54
Burner installation.....57
Burner removal.....53
- C**
Combustion chamber cleaning.....55
Commissioning.....30
Condensate.....18
Condensate drain.....18, 56
Connection diagram.....79
Connections.....15
Control unit, opening.....20
Cylinder temperature sensor69
- D**
Declaration of conformity.....100
- E**
Electrical connections.....21
- F**
Fault code.....62
Fault display.....62
Filling function.....30
Filling the system.....31
Flow limiter.....73
Flue gas cascade.....47
Flue gas temperature sensor.....72
Flue pipe.....19
Frost limit.....78
Frost protection.....78
Function sequence.....61
Fuse.....75
- G**
Gas connection.....16
Gas supply pressure.....34
Gas train34
Gas type conversion.....76
– LPG.....33
– Natural gas.....76
- H**
Heat exchanger cleaning.....55
Heating curve.....78
- I**
Ignition.....55
Ignition electrode.....55
Ionisation electrode.....55
- M**
Max. Heating output.....35
- O**
Outlet temperature sensor.....71
Output adjustment
– Multiple connection.....39
Output matching
– Flue gas cascade.....47
Outside temperature sensor66
- P**
Plate heat exchanger.....74
Power supply.....26
- R**
Reducing the heating output.....35
Reset.....65
- S**
Safety chain70
Safety valve.....18
Shared flue system connection.....39
Specification97
Static pressure.....34
Supply pressure.....34
System filling.....30
System pressure.....31

Keyword index (cont.)

T

Temperature limiter.....70
Trap..... 19, 56
Troubleshooting.....66

V

Ventilation air pipe.....19
Venting.....32
Vitolrol 100
– Connection.....26

W

Wall mounting.....12
Water side connections.....15
Weather-compensated mode.....78



Applicability

Serial No.:

7543420
7543424

7543421
7543425

7543422
7543426

7543423

Viessmann Werke GmbH&Co KG
D-35107 Allendorf
Telephone: +49 6452 70-0
Fax: +49 6452 70-2780
www.viessmann.com

Viessmann Limited
Hortonwood 30, Telford
Shropshire, TF1 7YP, GB
Telephone: +44 1952 675000
Fax: +44 1952 675040
E-mail: info-uk@viessmann.com

5677 216 GB Subject to technical modifications.